

WLK

OIL SEALS

















→ www.sylpanama.com

SYL International, S.A.
Power Transmission
TU PROVEEDOR ESTÉS DONDE ESTÉS











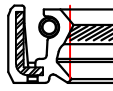
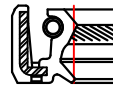
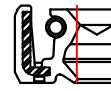





















France Field, Zona Libre de Colón. Panamá, Rep. de Panamá.

WLK TYPE ILLUSTRATION

1. Standard Types of oil Seals :

| Type Design | S Type Single Lip Spring Loaded | T Type Twin Lip Spring Loaded | V Type Single Lip Springless | K Type Twin Lip Springless | D Type Double garter Spring loaded Recommended Sealing for two media |
|---|---|---|---|---|---|
| C Rubber O.D. Design |  SC |  TC |  VC |  KC |  DC |
| B Metal O.D. Design |  SB |  TB |  VB |  KB |  DB |
| A Metal O.D. Design With reinforce case |  SA |  TA |  VA |  KA |  DA |

2. Other types of oil seals :

| | | | | | | | | | |
|--|---|---|---|---|--|---|---|---|--|
|  |  |  |  |  |  |  |  |  | |
| Helix Line Design | | | OD Grooved Rubber/Metal Outer | | Grooved Rubber Outer | | PTFE Lip Seals | | |
| HTCL | HTCR | HTCW | SBG | TBG | SG | TG | TCJ | KA3J | |
|  |  |  |  | | | | | | |
| House Rotate Design | | V-Ring | | | | | | | |
| OSC | OTC | VA = VR1 | VS = VR2 | | | | | | |
|  |  |  |  |  |  |  | | | |
| High Pressure Design | | | | | Shock Absorber Seals | | | | |
| SEC | TCA | TCN | TCV | TEC | DC4Y | TC4 | | | |
|  |  |  |  |  |  |  |  |  | |
| Power Steering Seals | | | | | | | | | |
| HPS | HPS(G) | SGJY | SCAJY | SCJY | SCJYI | ISZ | SD7 | TC4Y | |
|  |  |  |  |  |  | | | | |
| Spark Plug Holder Seals | | | | | | | | | |
| SCY | SCYI | VCY | Y1 | Y2 | Y3 | | | | |

WLK TYPE ILLUSTRATION

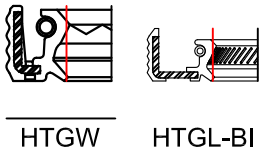
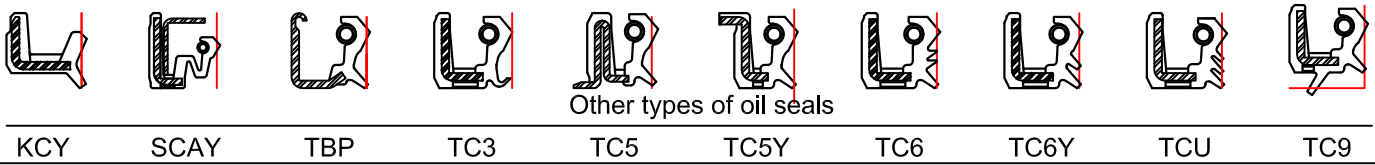
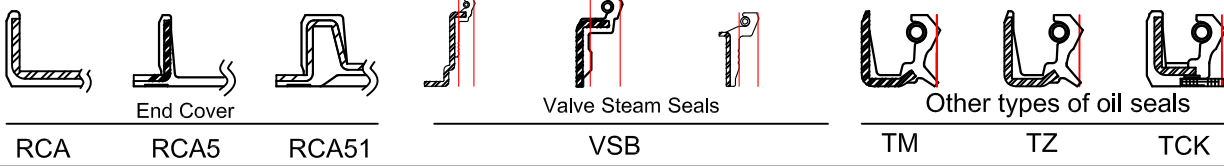

3. Design characteristics :

- TCK : TC Type seals with felt formed as dust lip.
- TCJ : TC Type seals with PTFE material Lip.
- O Type seals special for House rotate used.

WLK TYPE ILLUSTRATION

1. Standard Type of Oil Seals :

| Design Type | C Rubber O.D. Design | B Metal O.D. Design | A Metal O.D. Design With Reinforce Case |
|---|--------------------------------|-------------------------------|--|
| S Type Single Lip Spring Loaded | SC | SB | SA |
| T Type Twin Lip Spring Loaded | TC | TB | TA |
| V Type Single Lip Springless | VC | VB | VA |
| K Type Twin Lip Springless | KC | KB | KA |
| D Type Double Lip Spring Loaded Recommended Sealing for two media | DC | DB | DA |

2. Helix Line Design

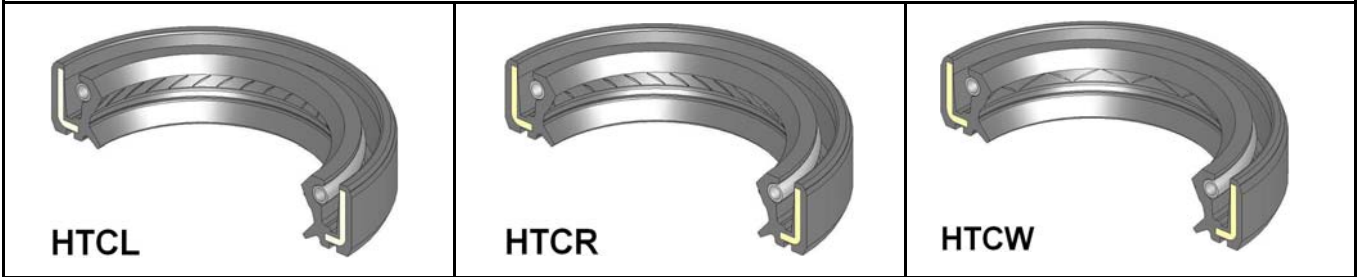

3. O.D. Grooved Rubber / Metal Outer

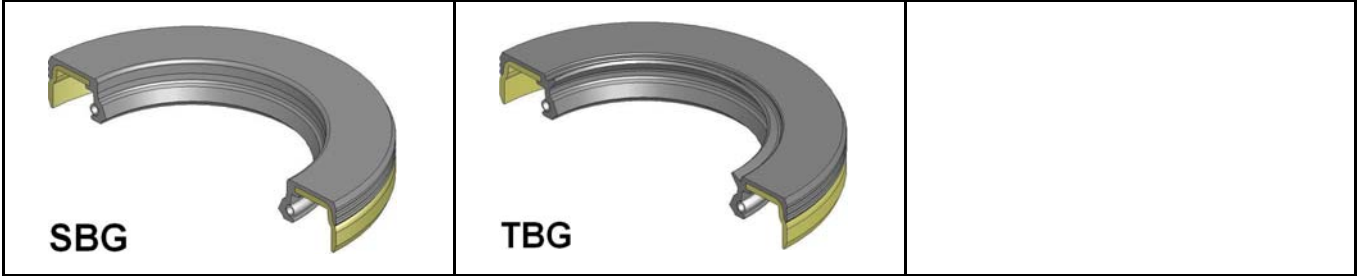

4. Grooved Rubber Outer

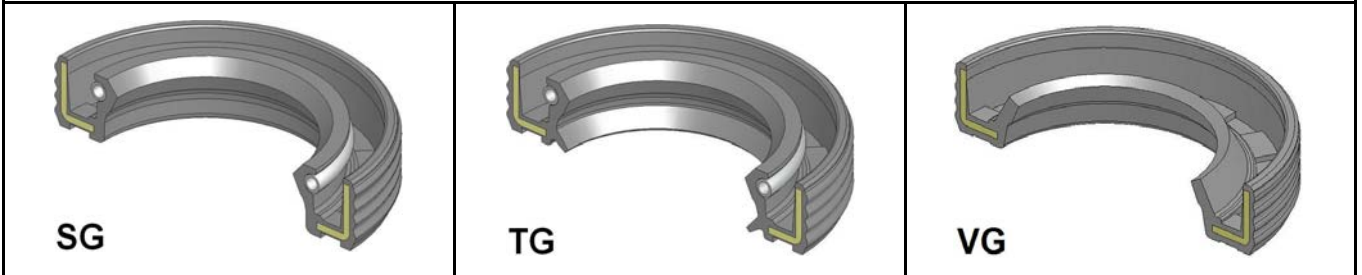

5. PTFE Lip Seals

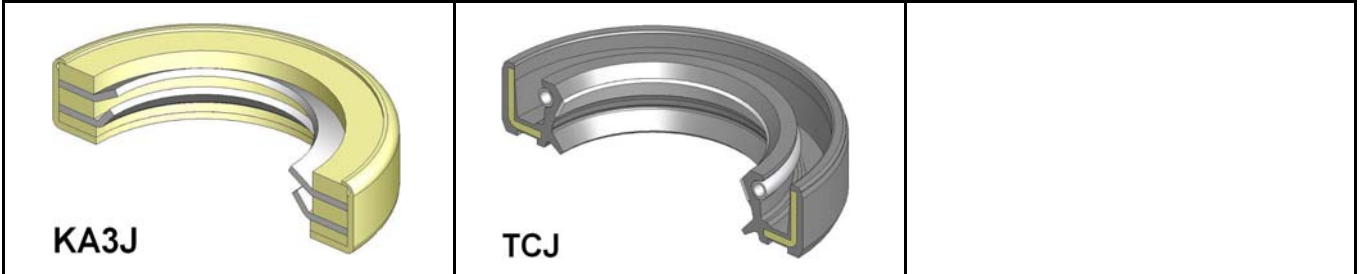

6. House Rotate Design

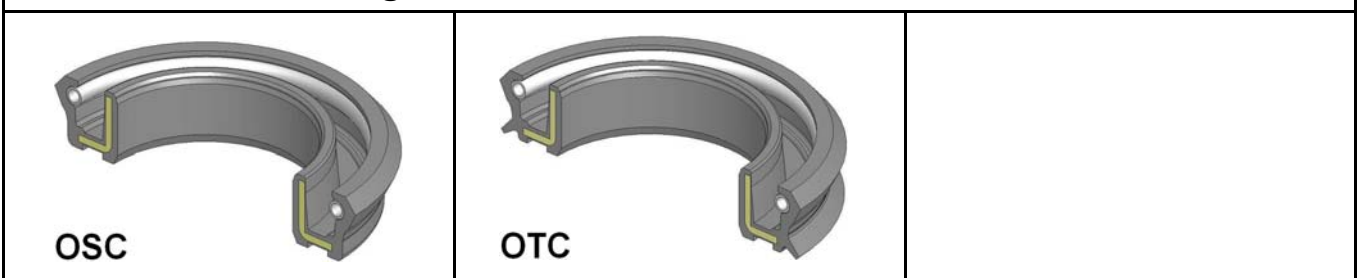

7. V-Ring

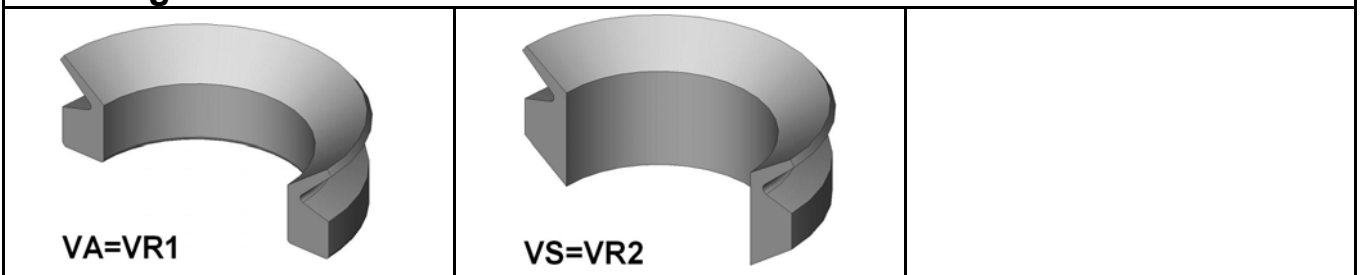

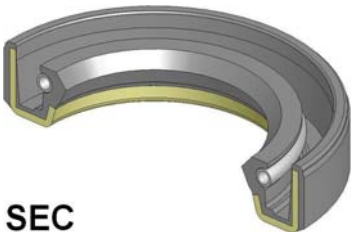
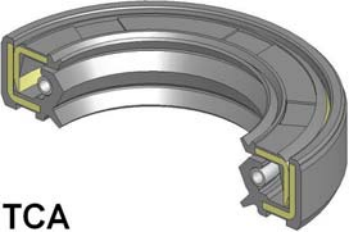
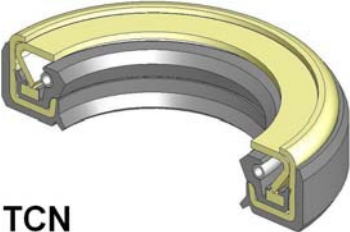
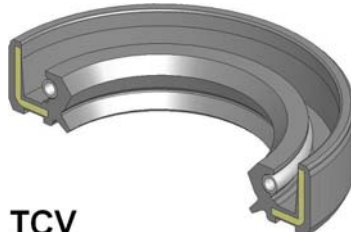
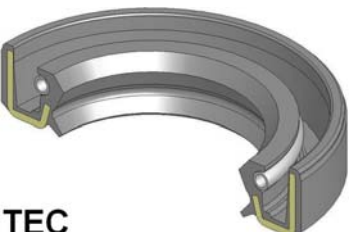
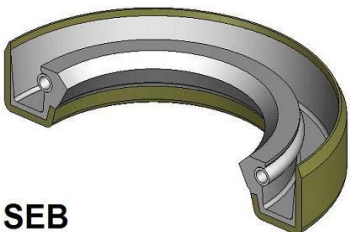

8. Anti-High Pressure Design

| | | |
|--|--|--|
|  <p>SEC</p> |  <p>TCA</p> |  <p>TCN</p> |
|  <p>TCV</p> |  <p>TEC</p> |  <p>SEB</p> |

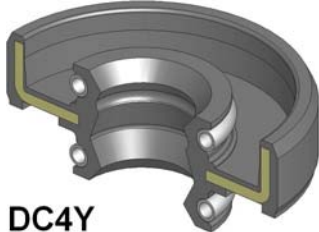
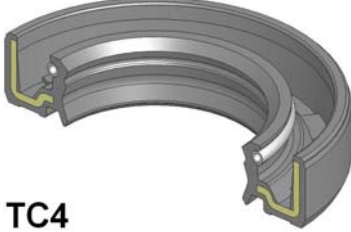
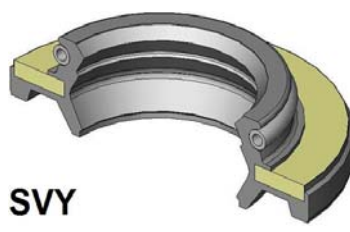

9. Shock Absorber used Seals

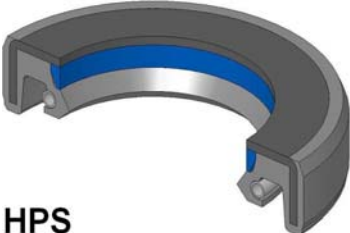
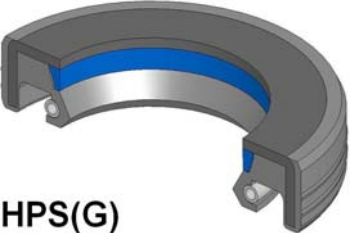
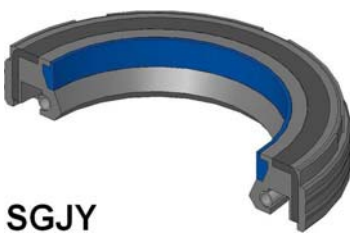
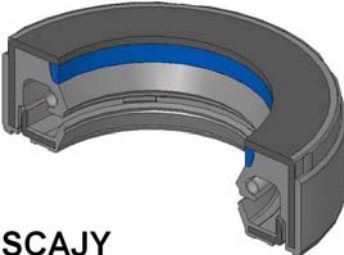
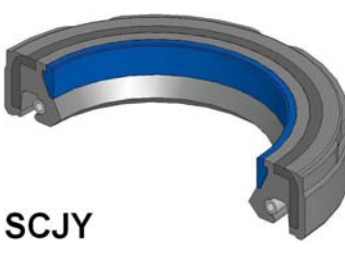
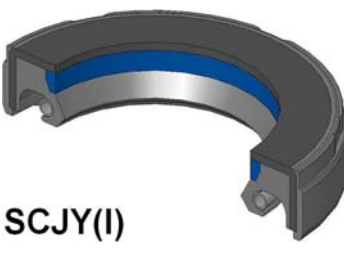
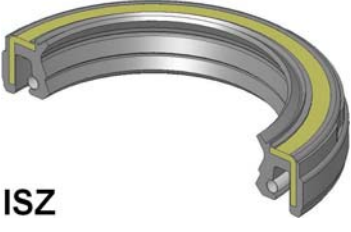
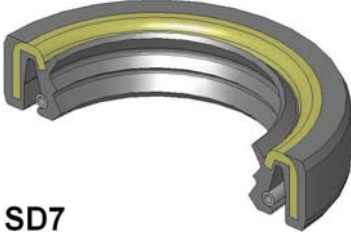
| | | |
|--|---|---|
|  <p>DC4Y</p> |  <p>TC4</p> |  <p>SVY</p> |
|--|---|---|

10. Power Steering used Seals

| | | |
|--|---|--|
|  <p>HPS</p> |  <p>HPS(G)</p> |  <p>SGJY</p> |
|  <p>SCAJY</p> |  <p>SCJY</p> |  <p>SCJY(I)</p> |
|  <p>ISZ</p> |  <p>SD7</p> |  <p>TC4Y</p> |

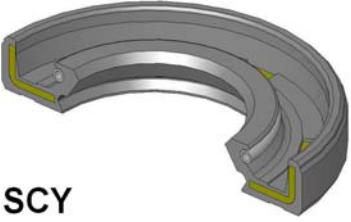
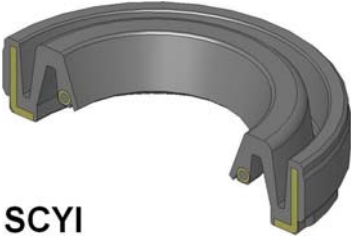
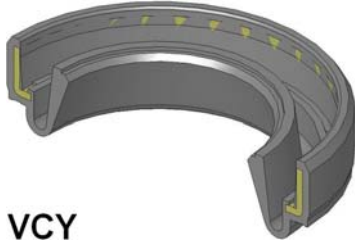
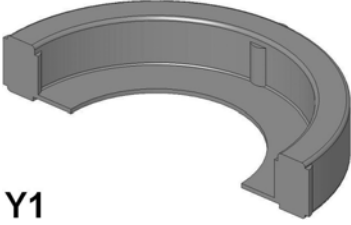
11. Spark Plug Holder used Seals

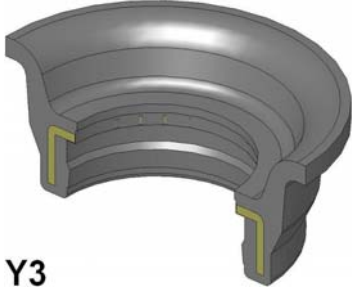
| | | |
|--|---|--|
|  <p>SCY</p> |  <p>SCYI</p> |  <p>VCY</p> |
|  <p>Y1</p> |  <p>Y2</p> |  <p>Y3</p> |

12. End Cover

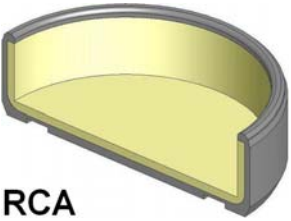
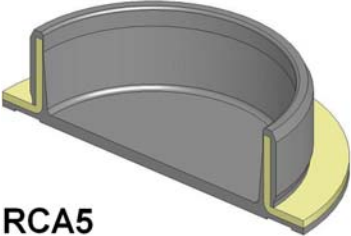
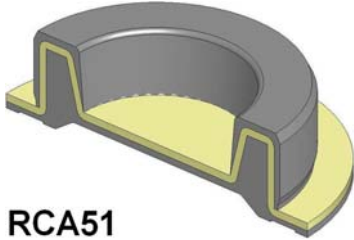
| | | |
|---|--|---|
|  <p>RCA</p> |  <p>RCA5</p> |  <p>RCA51</p> |
|---|--|---|

13. Valve Steam Seals

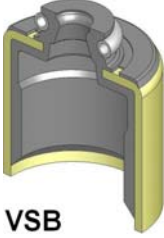
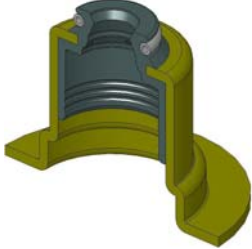
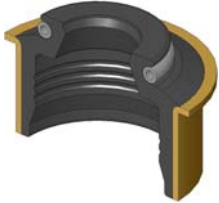

| | | |
|--|---|---|
|  <p>VSB</p> |  |  |
|--|---|---|

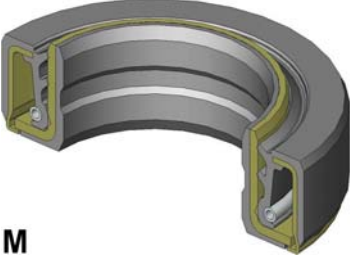
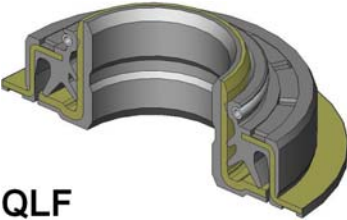
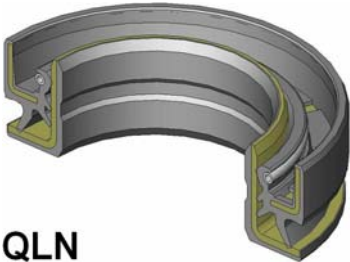
14. Complex Seals

| | | |
|--|--|--|
|  <p>M</p> |  <p>QLF</p> |  <p>QLN</p> |
|--|--|--|

| | | |
|--|--|--|
| | | |
|--|--|--|

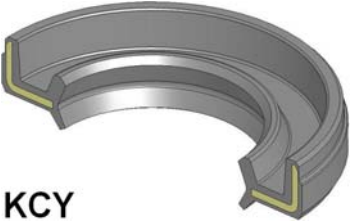
15. Other Type Seals

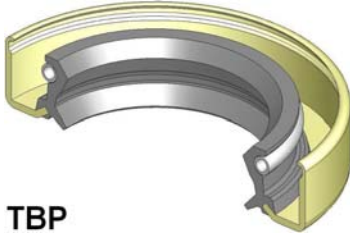
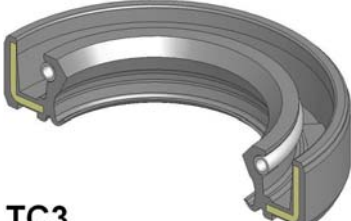
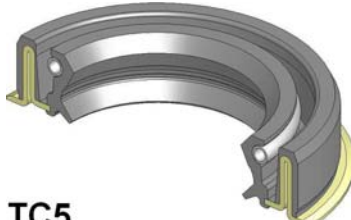
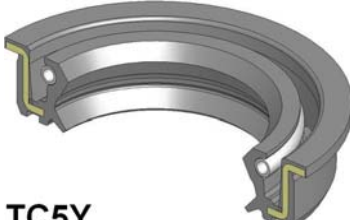
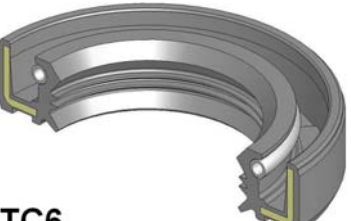
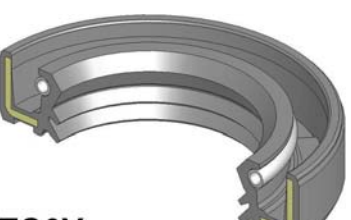
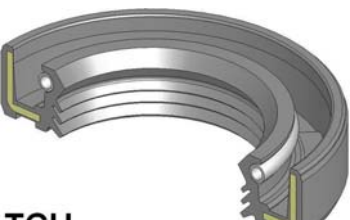
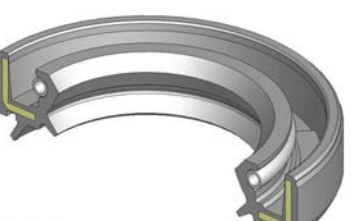
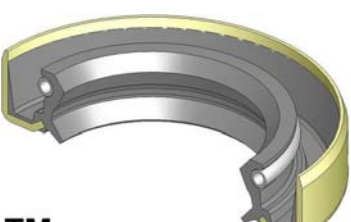
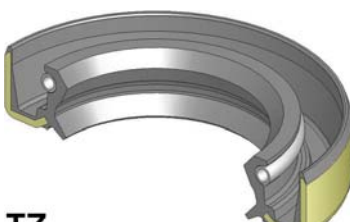
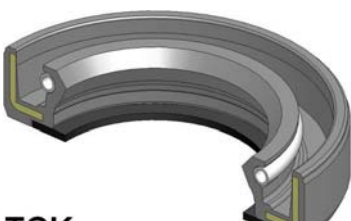
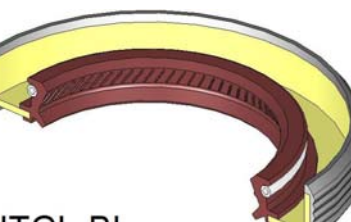
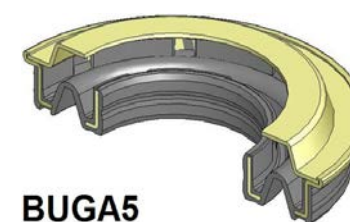
| | | |
|---|--|--|
|  <p>KCY</p> |  <p>SCAY</p> |  <p>TBP</p> |
|  <p>TC3</p> |  <p>TC5</p> |  <p>TC5Y</p> |
|  <p>TC6</p> |  <p>TC6Y</p> |  <p>TCU</p> |
|  <p>TC9</p> |  <p>TM</p> |  <p>TZ</p> |
| <p>TCK : with felt formed as Dust Lip.</p>  <p>TCK</p> |  <p>HTGL-BI</p> |  <p>BUGA5</p> |
| | | |

OIL SEALS / RETENES



Oil Seals Catalogue By SIZE

| WLK CODE | OIL SEALS | DESCRIPTION | ID | OD1 | OD2 | H1 | H2 |
|-----------|--------------------------|---------------------------|------|-------|------|-------|----|
| FSA0280N0 | 4*8*2 VC | | 4 | 8 | | 2 | |
| FSA0099N0 | 4*9*3 VC | 15586020 OIL PUMP | 4 | 9 | | 3 | |
| FSA0027N0 | 5.5*9*3 VC | | 5.5 | 9 | | 3 | |
| FSA0281N0 | 6*10*2 VC | | 6 | 10 | | 2 | |
| FSA0029N0 | 6.35*10.36*2.03 VC | 0.250*0.408*0.080 VC | 6.35 | 10.36 | | 2.03 | |
| FSA0186NB | 4*11*6 SC | | 4 | 11 | | 6 | |
| FSA0209N0 | 6*11*4 VC | | 6 | 11 | | 4 | |
| FSA0128N0 | 7.95*11.13/14.3*11.51PTF | 0.313*0.438/0.563*0.453 | 7.95 | 11.13 | 14.3 | 11.51 | |
| FSA0218NB | 4*12*6 SC | | 4 | 12 | | 6 | |
| FSA0247N0 | 5*12*3.5 VM | | 5 | 12 | | 3.5 | |
| FSA0103NB | 5*12*4.3/8 SC | | 5 | 12 | | 4.3 | 8 |
| FSA0086NB | 6*12*4 SC | EP500 | 6 | 12 | | 4 | |
| FSA0191N0 | 6*12*5 VC | | 6 | 12 | | 5 | |
| FSA0172N0 | 8*12*3 VG | | 8 | 12 | | 3 | |
| FSA0282N0 | 8*12*4 KC | | 8 | 12 | | 4 | |
| FSA9995N0 | 7.95*12.8*3.58 VM | 膠鐵分離 NBR80 | 7.95 | 12.8 | | 3.58 | |
| FSA0220NB | 5*13*7 SC | | 5 | 13 | | 7 | |
| FSA0264NB | 6*13*4.5 SC | | 6 | 13 | | 4.5 | |
| FSA0224NB | 6*13*4.5 VB | | 6 | 13 | | 4.5 | |
| FSA0169N0 | 8*13*3.5 VC | | 8 | 13 | | 3.5 | |
| FSA0253N0 | 5*14*4 VC | | 5 | 14 | | 4 | |
| FSA0148N0 | 5*14*5 KB(KM) | | 5 | 14 | | 5 | |
| FSA0030N0 | 7*14*4 VC | | 7 | 14 | | 4 | |
| FSA0176N0 | 8*14*3 VC | | 8 | 14 | | 3 | |
| FSA0260NB | 8*14*4 SB | | 8 | 14 | | 4 | |
| FSA0017NB | 8*14*4 SC | 久保田播手油封 | 8 | 14 | | 4 | |
| FSA0017FB | 8*14*4 SC(VITON)FKM | | 8 | 14 | | 4 | |
| FSA0124F0 | 8*14*4 VC (VITON) | FKM | 8 | 14 | | 4 | |
| FSA0042NB | 8*14*5 SC | | 8 | 14 | | 5 | |
| FSA0179NB | 8*14*5 TC | | 8 | 14 | | 5 | |
| FSA0179NS | 8*14*5 TC(S304)BLUE | | 8 | 14 | | 5 | |
| FSA0238NB | 8*14*7 TC | | 8 | 14 | | 7 | |
| FSA0016NB | 8*14/21*8/16 TCY | 久保田播手擋泥橡膠 | 8 | 14 | 21 | 8 | 16 |
| FSA0115N0 | 10*14*2.5 VC | | 10 | 14 | | 2.5 | |
| FSA0192N0 | 10*14*3 VG | | 10 | 14 | | 3 | |
| FSA0131FB | 7.92*14.27*3.175 VM(FKM) | 0.312*0.562*0.125 VM(FKM) | 7.92 | 14.27 | | 3.175 | |
| FSA0131NB | 7.92*14.27*3.175 VM(VB) | 0.312*0.562*0.125 VM(VB) | 7.92 | 14.27 | | 3.175 | |
| FSA0135N0 | 9.53*14.28*2.39 VM | 0.375*0.562*0.094 VM | 9.53 | 14.28 | | 2.39 | |
| FSA0102N0 | 6.5*14.5*7 KC | 91201-324-013 | 6.5 | 14.5 | | 7 | |
| FSA0101N0 | 7*14.5*3 軟 | | 7 | 14.5 | | 3 | |
| FSA0178N0 | 4.8*15*5/6 KC | | 4.8 | 15 | | 5 | 6 |
| FSA0106N0 | 5*15*5 KC | | 5 | 15 | | 5 | |
| FSA0028NB | 5*15*6 SC | | 5 | 15 | | 6 | |
| FSA0237NB | 5*15*6 TC | | 5 | 15 | | 6 | |
| FSA0204N0 | 6*15*5 VC | | 6 | 15 | | 5 | |
| FSA0168NB | 6*15*6 SC | | 6 | 15 | | 6 | |
| FSA0262NB | 6*15*7 TC | | 6 | 15 | | 7 | |
| FSA0150NB | 7*15*5 SC | | 7 | 15 | | 5 | |
| FSA0037NB | 7*15*5 TC | | 7 | 15 | | 5 | |
| FSA0022N0 | 8*15*3 VC | | 8 | 15 | | 3 | |
| FSA0043NB | 8*15*5 TC | | 8 | 15 | | 5 | |
| FSA0240NB | 8*15*8 SC | | 8 | 15 | | 8 | |

| WLK CODE | OIL SEALS | DESCRIPTION | ID | OD1 | OD2 | H1 | H2 |
|-----------|-------------------------|----------------------|------|-------|-----|------|-----|
| FSA0230N0 | 9*15*4 VC | | 9 | 15 | | 4 | |
| FSA0248N0 | 10*15*3 VC | | 10 | 15 | | 3 | |
| FSA0041N0 | 10*15*4 VC | | 10 | 15 | | 4 | |
| FSA0041A0 | 10*15*4 VC (ACM) | (ACM) | 10 | 15 | | 4 | |
| FSA0100N0 | 10.5*15*3 KC | | 10.5 | 15 | | 3 | |
| FSA0023N0 | 9*15.1*4 VC | | 9 | 15.1 | | 4 | |
| FSA0121N0 | 8*15.5*5.9 | | 8 | 15.5 | | 5.9 | |
| FSA0147NB | 7.14*15.80*7.49 TC4 | 8*16*7.A | 7.14 | 15.8 | | 7.49 | |
| FSA0010NB | 6.35*15.88*6.35 SC | 0.250*0.625*0.250 SC | 6.35 | 15.88 | | 6.35 | |
| FSA0219NB | 4*16*6 TC | | 4 | 16 | | 6 | |
| FSA0084NB | 4.5*16*7 DV(KC) | | 4.5 | 16 | | 7 | |
| FSA0151N0 | 4.5*16*7 KG3 | 113LG39 | 4.5 | 16 | | 7 | |
| FSA0195NB | 4.5*16*7 TG | | 4.5 | 16 | | 7 | |
| FSE0503N0 | 4.5*16/57*7 FLAT | 113LG92 | 4.5 | 16 | 57 | 7 | |
| FSE0130NB | 4.5*16/57*7/8.5 FLAT | | 4.5 | 16 | 57 | 7 | 8.5 |
| FSA0284NB | 5*16*6 SC | | 5 | 16 | | 6 | |
| FSA0235NB | 5*16*6 TC | | 5 | 16 | | 6 | |
| FSA0208NB | 5*16*7 SC | | 5 | 16 | | 7 | |
| FSA0221NB | 5*16*7 TC | | 5 | 16 | | 7 | |
| FSA0098N0 | 5.5*16*8 KC6 | 09285-05004 | 5.5 | 16 | | 8 | |
| FSA0009NB | 5.5*16*8 TC | | 5.5 | 16 | | 8 | |
| FSA0065NB | 6*16*5 TC | | 6 | 16 | | 5 | |
| FSA0167NB | 6*16*6 SC | | 6 | 16 | | 6 | |
| FSA0158NB | 6*16*7 SC | | 6 | 16 | | 7 | |
| FSA0171NB | 6*16*7 TC | | 6 | 16 | | 7 | |
| FSA0294N0 | 7*16*4.5 VC | | 7 | 16 | | 4.5 | |
| FSA0097N0 | 7*16*5.7 VBY | | 7 | 16 | | 5.7 | |
| FSA0038NB | 7*16*7 TC | | 7 | 16 | | 7 | |
| FSA0034N0 | 8*16*3 VC | | 8 | 16 | | 3 | |
| FSA0173NB | 8*16*5 SB | | 8 | 16 | | 5 | |
| FSA0250NB | 8*16*5 SC | | 8 | 16 | | 5 | |
| FSA0206NB | 8*16*5 TC | | 8 | 16 | | 5 | |
| FSA0014NB | 8*16*6 TC | 958-60-8166 | 8 | 16 | | 6 | |
| FSA0125NB | 8*16*7 TC | 9958-60-8166 | 8 | 16 | | 7 | |
| FSA0125QB | 8*16*7 TC(VMQ)White | | 8 | 16 | | 7 | |
| FSA0139NB | 8*16*7 TC4 | | 8 | 16 | | 7 | |
| FSA0050NB | 8.5*16*13 SBY Dark Blue | 006 99 79 047 | 8.5 | 16 | | 13 | |
| FSA0245NB | 9*16*4 SC | | 9 | 16 | | 4 | |
| FSA0231NB | 9*16*5 SC | | 9 | 16 | | 5 | |
| FSA0051NB | 9*16*6/9 SBY Dark Blue | 89013 | 9 | 16 | | 6 | 9 |
| FSA0249N0 | 10*16*3 VC | | 10 | 16 | | 3 | |
| FSA0257NB | 10*16*3/4.5 GA | | 10 | 16 | | 3 | 4.5 |
| FSA0057NB | 10*16*4 HSC | | 10 | 16 | | 4 | |
| FSA0058NB | 10*16*4 SC | | 10 | 16 | | 4 | |
| FSA0058FB | 10*16*4 SC (FKM) | | 10 | 16 | | 4 | |
| FSA0241NB | 10*16*4 TC | | 10 | 16 | | 4 | |
| FSA0286NB | 10*16*4 VB | | 10 | 16 | | 4 | |
| FSA0059NB | 10*16*5 SC | | 10 | 16 | | 5 | |
| FSA0060NB | 10*16*6 SB | 89014 | 10 | 16 | | 6 | |
| FSA0120N0 | 12*16*3 VB | | 12 | 16 | | 3 | |
| FSA0120F0 | 12*16*3 VB (FKM) | FKM | 12 | 16 | | 3 | |
| FSA0118N0 | 8.5*16.5*5 軟 | | 8.5 | 16.5 | | 5 | |
| FSA0214NB | 5*17*7 TC | | 5 | 17 | | 7 | |
| FSA0288NB | 6*17*6 SC | | 6 | 17 | | 6 | |
| FSA0225NB | 6*17*7 TC | | 6 | 17 | | 7 | |
| FSA0105N0 | 8*17*4.5 軟 | 并關插秧機用 | 8 | 17 | | 4.5 | |
| FSA0145NB | 8*17*5 TC | | 8 | 17 | | 5 | |

| WLK CODE | OIL SEALS | DESCRIPTION | ID | OD1 | OD2 | H1 | H2 |
|-----------|----------------------|-----------------------|------|-------|-----|------|------|
| FSA0228N0 | 8*17*5 VC | | 8 | 17 | | 5 | |
| FSA0243NB | 8*17*7 TC | | 8 | 17 | | 7 | |
| FSA0008NB | 8*17*8 SC | | 8 | 17 | | 8 | |
| FSA0170NB | 9*17*4.5 SB | | 9 | 17 | | 4.5 | |
| FSA0232NB | 9*17*5 TC | | 9 | 17 | | 5 | |
| FSA0024N0 | 10*17*3 VB (VM) | 刀角 | 10 | 17 | | 3 | |
| FSA0122NB | 10*17*5 SB (SZ) | 09282-10001 | 10 | 17 | | 5 | |
| FSA0142NB | 10*17*5 TC | | 10 | 17 | | 5 | |
| FSA0088NB | 10*17*5 VC | 09284-10002 | 10 | 17 | | 5 | |
| FSA0266NB | 10*17*6 SC | | 10 | 17 | | 6 | |
| FSA0140NB | 10*17*7 TC | | 10 | 17 | | 7 | |
| FSA0067NB | 11*17*4 SC | | 11 | 17 | | 4 | |
| FSA0291NB | 11*17*4 TB | | 11 | 17 | | 4 | |
| FSA0165NB | 11*17*4 TC | | 11 | 17 | | 4 | |
| FSA0007NB | 4.4*17.2*8 SC | | 4.4 | 17.2 | | 8 | |
| FSA0055NB | 8*17.4*5/7 KCY | AR0139-E | 8 | 17.4 | | 5 | 7 |
| FSA0006NB | 7.92*17.42*8.15 TC4 | 0.312*0.686*0.321 TC4 | 7.92 | 17.42 | | 8.15 | |
| FSA0095N0 | 8.5*17.5*9 軟 | | 8.5 | 17.5 | | 9 | |
| FSA0093NB | 5*18*7 SC | | 5 | 18 | | 7 | |
| FSA0246NB | 5*18*7 TC | | 5 | 18 | | 7 | |
| FSA0031NB | 6*18*5 SC | | 6 | 18 | | 5 | |
| FSA0205NB | 6*18*6 TC | | 6 | 18 | | 6 | |
| FSA0032NB | 6*18*7 SC | | 6 | 18 | | 7 | |
| FSA0004NB | 6*18*7 TC | | 6 | 18 | | 7 | |
| FSA0039NB | 7*18*7 SC | | 7 | 18 | | 7 | |
| FSA0144NB | 7*18*7 TC | | 7 | 18 | | 7 | |
| FSA0035N0 | 8*18*4 VC | | 8 | 18 | | 4 | |
| FSA0116N0 | 8*18*4/6 VCY | | 8 | 18 | | 4 | 6 |
| FSA0005N0 | 8*18*5 KC | | 8 | 18 | | 5 | |
| FSA0005Q0 | 8*18*5 KC (VMQ) | (VMQ) | 8 | 18 | | 5 | |
| FSA0005F0 | 8*18*5 KC VITON(FKM) | | 8 | 18 | | 5 | |
| FSA0003NB | 8*18*5 SC | | 8 | 18 | | 5 | |
| FSA0012NB | 8*18*5 TC | 93210-14104 | 8 | 18 | | 5 | |
| FSA0012FB | 8*18*5 TC (FKM)VITON | | 8 | 18 | | 5 | |
| FSA0012N0 | 8*18*5 TC w/o spring | | 8 | 18 | | 5 | |
| FSA0184NB | 8*18*5 TC4 | | 8 | 18 | | 5 | |
| FSA0094N0 | 8*18*5 VC | | 8 | 18 | | 5 | |
| FSA0019N0 | 8*18*5.7 KB | 三菱播手油封 | 8 | 18 | | 5.7 | |
| FSA0092N0 | 8*18*5.8 VC | | 8 | 18 | | 5.8 | |
| FSA0261NB | 8*18*6 SC | | 8 | 18 | | 6 | |
| FSA0161NB | 8*18*7 SC | | 8 | 18 | | 7 | |
| FSA0002NB | 8*18*7 TC4(BROWN) | 三菱播手油封 | 8 | 18 | | 7 | |
| FSA0091N0 | 8*18*8 KCY | | 8 | 18 | | 8 | |
| FSA0160NB | 8*18*8/19 TC65Y | 8*18/24*8/19 TC65Y | 8 | 18 | | 8 | 19 |
| FSA0138NB | 8*18*8/19 TCY | 8*18/24*8/19 TC65Y | 8 | 18 | | 8 | 19 |
| FSA0021N0 | 8*18*9 軟 | 野馬推苗桿油封(內面) | 8 | 18 | | 9 | |
| FSA0133NB | 8*18*10/14.5 KC4Y | 三菱用 | 8 | 18 | | 10 | 14.5 |
| FSA0020N0 | 8*18/26*16 | 野馬推苗桿油封(外面) | 8 | 18 | 26 | 16 | |
| FSA0089NB | 8*18/26*16.5 TCY | 野馬推苗桿油封(外面) | 8 | 18 | 26 | 16.5 | |
| FSA0104N0 | 8*18*17 VC | | 8 | 18 | | 17 | |
| FSA0011NB | 8*18/23*19 TCY | | 8 | 18 | 23 | 19 | |
| FSA0015NB | 9*18*5 TC | | 9 | 18 | | 5 | |
| FSA0279NB | 9*18*6 SC | | 9 | 18 | | 6 | |
| FSA0187NB | 9*18*7 SC | | 9 | 18 | | 7 | |
| FSA0233NB | 9*18*7 TC | | 9 | 18 | | 7 | |
| FSA0061NB | 10*18*4 SB | | 10 | 18 | | 4 | |

| WLK CODE | OIL SEALS | DESCRIPTION | ID | OD1 | OD2 | H1 | H2 |
|-----------|------------------------|----------------------|----|------|-----|-----|-----|
| FSA0062NB | 10*18*4 SC | | 10 | 18 | | 4 | |
| FSA0207NB | 10*18*4 TC(BLUE) | | 10 | 18 | | 4 | |
| FSA0063NB | 10*18*5 SC | | 10 | 18 | | 5 | |
| FSA0143NB | 10*18*5 TC | | 10 | 18 | | 5 | |
| FSA0146NB | 10*18*5/8 DCY Green | | 10 | 18 | | 5 | 8 |
| FSA0152NB | 10*18*6 TC | | 10 | 18 | | 6 | |
| FSA0193NB | 10*18*7 TC | | 10 | 18 | | 7 | |
| FSA0193FB | 10*18*7 TC(FKM)VITON | | 10 | 18 | | 7 | |
| FSA0258NB | 10*18*8 TC | | 10 | 18 | | 8 | |
| FSA0267NB | 10*18*9 SC | | 10 | 18 | | 9 | |
| FSA0046N0 | 11*18*3 VC | | 11 | 18 | | 3 | |
| FSA0149NB | 11*18*4 SC | | 11 | 18 | | 4 | |
| FSA0068NB | 11*18*4 TC | | 11 | 18 | | 4 | |
| FSA0185NB | 11*18*5 SB | | 11 | 18 | | 5 | |
| FSA0154NB | 12*18*3 VC | | 12 | 18 | | 3 | |
| FSA0177N0 | 12*18*3 VG | | 12 | 18 | | 3 | |
| FSA0255NB | 12*18*4 SB | | 12 | 18 | | 4 | |
| FSA0136NB | 12*18*4 SC | | 12 | 18 | | 4 | |
| FSA0268NB | 12*18*4.5 SC | | 12 | 18 | | 4.5 | |
| FSA0292NB | 12*18*5 TC | | 12 | 18 | | 5 | |
| FSA0090N0 | 12*18*5 VB | | 12 | 18 | | 5 | |
| FSA0194NB | 12*18*6 SB | | 12 | 18 | | 6 | |
| FSA0069NB | 12*18*6.7 SB Dark Blue | 006 99 70 147 | 12 | 18 | | 6.7 | |
| FSA0190N0 | 9*18.8*6.4/8.4 軟 | Mondeo 2.0宇宙汽門蓋螺絲 | 9 | 18.8 | | 6.4 | 8.4 |
| FSA0222NB | 5*19*5 TC | | 5 | 19 | | 5 | |
| FSA0256P0 | 6*19*3 VBJ(PTFE) | 鐵氟龍(PTFE) | 6 | 19 | | 3 | |
| FSA0259N0 | 6*19*4 KC | | 6 | 19 | | 4 | |
| FSA0254N0 | 6*19*4 VC | | 6 | 19 | | 4 | |
| FSA0033NB | 6*19*7 TC | 09285-06006, 113LG66 | 6 | 19 | | 7 | |
| FSA0107N0 | 6*19*7/8 KCY | | 6 | 19 | | 7 | 8 |
| FSA0227NB | 7*19*7 TC | | 7 | 19 | | 7 | |
| FSA0229NB | 8*19*7 TC | | 8 | 19 | | 7 | |
| FSA0049NB | 8*19*8 TC4 | | 8 | 19 | | 8 | |
| FSA0265NB | 9*19*4 SC | | 9 | 19 | | 4 | |
| FSA0053NB | 9*19*5 SC | | 9 | 19 | | 5 | |
| FSA0054NB | 9*19*5 TA | | 9 | 19 | | 5 | |
| FSA0183NB | 9*19*5 TC | | 9 | 19 | | 5 | |
| FSA0251NB | 9*19*6 TC | | 9 | 19 | | 6 | |
| FSA0234NB | 9*19*7 TM | | 9 | 19 | | 7 | |
| FSA0123P0 | 10*19*3 VBJ (PTFE) | 鐵氟龍(PTFE) | 10 | 19 | | 3 | |
| FSA0159NB | 10*19*4 SC | | 10 | 19 | | 4 | |
| FSA0182NB | 10*19*5 KB | | 10 | 19 | | 5 | |
| FSA0239QB | 10*19*7 SC(VMQ) | | 10 | 19 | | 7 | |
| FSA0064NB | 10*19*7 TC | | 10 | 19 | | 7 | |
| FSA0200NB | 11*19*5 SC | | 11 | 19 | | 5 | |
| FSA0285NB | 11*19*7 TC | | 11 | 19 | | 7 | |
| FSA0082N0 | 12*19*2.8 VB (VZ) | 12.7*19*2.8 VB (實尺寸) | 12 | 19 | | 2.8 | |
| FSA0119NB | 12*19*3 VB (VM) | | 12 | 19 | | 3 | |
| FSA0087NB | 12*19*3 VC | | 12 | 19 | | 3 | |
| FSA0180NB | 12*19*4 TC | | 12 | 19 | | 4 | |
| FSA0156NB | 12*19*5 SB | | 12 | 19 | | 5 | |
| FSA0289NB | 12*19*5 SC | | 12 | 19 | | 5 | |
| FSA0134NB | 12*19*5 TC | | 12 | 19 | | 5 | |
| FSA0018N0 | 12*19*5 VC | 93109-122012 機車 | 12 | 19 | | 5 | |
| FSA0141NB | 12*19*7 TC | | 12 | 19 | | 7 | |
| FSA0203N0 | 13*19*3 VC | | 13 | 19 | | 3 | |
| FSA0163NB | 13*19*3 VG | | 13 | 19 | | 3 | |

| WLK CODE | OIL SEALS | DESCRIPTION | ID | OD1 | OD2 | H1 | H2 |
|-----------|-------------------------|---------------------------|------|-------|------|------|-----|
| FSA0293NB | 13*19*4 TB | | 13 | 19 | | 4 | |
| FSA0287NB | 13*19*4 TC | | 13 | 19 | | 4 | |
| FSA9999NB | 6.35*19.05*6.35 SC | | 6.35 | 19.05 | | 6.35 | |
| FSA9994NB | 7.95*19.05*6.35 SC | | 7.95 | 19.05 | | 6.35 | |
| FSA0001NB | 9.53*19.05*6.35 SC | 0.375*0.750*0.250 SC | 9.53 | 19.05 | | 6.35 | |
| FSA0001FB | 9.53*19.05*6.35 SC(FKM) | 0.375*0.750*0.250 SC(FKM) | 9.53 | 19.05 | | 6.35 | |
| FSA9997N0 | 9.53*19.05*6.35 VC | | 9.53 | 19.05 | | 6.35 | |
| FSA9996N0 | 12.7*19.05*3.18 VC | | 12.7 | 19.05 | | 3.18 | |
| FSA0070NB | 12.7*19.05*4.75 TC | 0.500*0.750*0.187 TC | 12.7 | 19.05 | | 4.75 | |
| FSA9998N0 | 12.7*19.05*4.78 VC | | 12.7 | 19.05 | | 4.78 | |
| FSA0226NB | 6*20*5.5 TC | | 6 | 20 | | 5.5 | |
| FSA0076NB | 6*20*6 TC | | 6 | 20 | | 6 | |
| FSA0244NB | 6*20*7 TC | | 6 | 20 | | 7 | |
| FSA0198NB | 8*20*5 TC | | 8 | 20 | | 5 | |
| FSA0196NB | 8*20*7 SC | | 8 | 20 | | 7 | |
| FSA0213NB | 8*20*7 TC | | 8 | 20 | | 7 | |
| FSA0213FB | 8*20*7 TC(VITON) | | 8 | 20 | | 7 | |
| FSA0073NB | 8*20*8 SC | | 8 | 20 | | 8 | |
| FSA0212NB | 8*20*8 TC4 | | 8 | 20 | | 8 | |
| FSA0137NB | 9*20*4 KC | 内径仕上 8.7MM正負0.10 | 9 | 20 | | 4 | |
| FSA0199NB | 9*20*6 SC | | 9 | 20 | | 6 | |
| FSA0188NB | 9*20*7 TC | | 9 | 20 | | 7 | |
| FSA0078NB | 10*20*4 SC | | 10 | 20 | | 4 | |
| FSA0155NB | 10*20*4 TC | | 10 | 20 | | 4 | |
| FSA0290NB | 10*20*5 TB | | 10 | 20 | | 5 | |
| FSA0153NB | 10*20*5 TC | | 10 | 20 | | 5 | |
| FSA0211NB | 10*20*5.5/7.5 HTCAL | | 10 | 20 | | 5.5 | 7.5 |
| FSA0071NB | 10*20*6 SC | | 10 | 20 | | 6 | |
| FSA0075NB | 10*20*7 SC | | 10 | 20 | | 7 | |
| FSA0075FB | 10*20*7 SC (FKM) Black | VITON | 10 | 20 | | 7 | |
| FSA0074NB | 10*20*7 TC | | 10 | 20 | | 7 | |
| FSA0189NB | 11*20*5 SB | | 11 | 20 | | 5 | |
| FSA0252NB | 11*20*7 TC | | 11 | 20 | | 7 | |
| FSA0052NB | 12*20*5 SB Green | 920490041 | 12 | 20 | | 5 | |
| FSA0080NB | 12*20*5 TC | 1C656063220 | 12 | 20 | | 5 | |
| FSA0083NB | 12*20*5 VC | | 12 | 20 | | 5 | |
| FSA0215NB | 12*20*6 TB | 34-596 | 12 | 20 | | 6 | |
| FSA0157NB | 12*20*6 TC | | 12 | 20 | | 6 | |
| FSA0081NB | 12*20*7 TC | | 12 | 20 | | 7 | |
| FSA0216NB | 12*20*8 DC | | 12 | 20 | | 8 | |
| FSA0269NB | 12.5*20*5 SC | | 12.5 | 20 | | 5 | |
| FSA0197NB | 13*20*4/4.5 TBY(BLUE1) | | 13 | 20 | | 4 | 4.5 |
| FSA0130N0 | 13*20*5 KB(KM) | 90313-13001 | 13 | 20 | | 5 | |
| FSA0132NB | 13*20*5 TB | | 13 | 20 | | 5 | |
| FSA0129NB | 13*20*5 TC | | 13 | 20 | | 5 | |
| FSA0242NB | 13*20*7 TC | | 13 | 20 | | 7 | |
| FSA0048N0 | 14*20*3 KB(KM) | K1420 | 14 | 20 | | 3 | |
| FSA0164NB | 14*20*3 VC | | 14 | 20 | | 3 | |
| FSA0174N0 | 14*20*4 KC | | 14 | 20 | | 4 | |
| FSA0181NB | 14*20*5 SC | | 14 | 20 | | 5 | |
| FSA0162N0 | 14*20*5 VC | | 14 | 20 | | 5 | |
| FSA0217NB | 14*20*7 TC | | 14 | 20 | | 7 | |
| FSA0045N0 | 16*20*2.5 VB | | 16 | 20 | | 2.5 | |
| FSE0506N0 | 5*21/54.5*9 Y軟 | 113LG96 | 5 | 21 | 54.5 | 9 | |
| FSE0504N0 | 6*21/53*8 FLAT軟 | 113LG90 | 6 | 21 | 53 | 8 | |
| FSB0326NB | 8*21*6 TC | | 8 | 21 | | 6 | |
| FSB1131NB | 10*21*4 TC | | 10 | 21 | | 4 | |

| WLK CODE | OIL SEALS | DESCRIPTION | ID | OD1 | OD2 | H1 | H2 |
|-----------|-------------------------|-------------------------|-------|-------|-----|------|------|
| FSB0204NB | 10*21*5 SC | | 10 | 21 | | 5 | |
| FSB0066NB | 10*21*5 TC | | 10 | 21 | | 5 | |
| FSB0066FB | 10*21*5 TC (FKM) | | 10 | 21 | | 5 | |
| FSB0066FS | 10*21*5 TC (FKM) S304 | (VITON) SUS304 SPRING | 10 | 21 | | 5 | |
| FSB0066NS | 10*21*5 TC(S304 SPRING) | | 10 | 21 | | 5 | |
| FSB0340NB | 10*21*7 TC | | 10 | 21 | | 7 | |
| FSB1006NB | 11*21*7 TC | | 11 | 21 | | 7 | |
| FSB0343NB | 11*21*8 TC | | 11 | 21 | | 8 | |
| FSB0224NB | 12*21*4 TC | | 12 | 21 | | 4 | |
| FSB0164N0 | 12*21*4 VC | 93102-12060 DT125/DT175 | 12 | 21 | | 4 | |
| FSB0088NB | 12*21*5 SC | | 12 | 21 | | 5 | |
| FSB1099NB | 12*21*5 TC | | 12 | 21 | | 5 | |
| FSB0619NB | 12*21*7 TC | | 12 | 21 | | 7 | |
| FSB0361NB | 12.5*21*7 TC3 | | 12.5 | 21 | | 7 | |
| FSB1030N0 | 14*21*3 VC | | 14 | 21 | | 3 | |
| FSB1010NB | 14*21*7 TC | | 14 | 21 | | 7 | |
| FSB0649NB | 15*21*3 VB | | 15 | 21 | | 3 | |
| FSB0163N0 | 15*21*3 VC | | 15 | 21 | | 3 | |
| FSB1013NB | 15*21*4 TC | | 15 | 21 | | 4 | |
| FSB1132NB | 15*21*5 SC | | 15 | 21 | | 5 | |
| FSE0151N0 | 6*21.5/55*12 FLAT(軟) | 113LG75 | 6 | 21.5 | 55 | 12 | |
| FSB9949NB | 15.88*21.63*8.74 SCY | LMB-000/721-0362 | 15.88 | 21.63 | | 8.74 | |
| FSB9948NB | 15.47*21.82*5.16 TCY | | 15.47 | 21.82 | | 5.16 | |
| FSB0102NB | 4.8*22*7 HKCR(Blue) | | 4.8 | 22 | | 7 | |
| FSB0162N0 | 4.8*22*7 VC | | 4.8 | 22 | | 7 | |
| FSA0223NB | 5*22*7 TC | | 5 | 22 | | 7 | |
| FSE0150N0 | 5*22/53*11 FLAT(軟) | 113LG76 | 5 | 22 | 53 | 11 | |
| FSB0065NB | 6*22*7 DV(KC) | 113 LG 06 | 6 | 22 | | 7 | |
| FSB0064NB | 6*22*7 TC | 113LG05 | 6 | 22 | | 7 | |
| FSB1110NB | 6*22*8 TC | | 6 | 22 | | 8 | |
| FSE0507N0 | 6*22/59*8/11.5 Y軟 | 113LG95 | 6 | 22 | 59 | 8 | 11.5 |
| FSF0262N0 | 6*22/67*8/10 FLAT(軟) | 113LG77 | 6 | 22 | 67 | 8 | 10 |
| FSB0171N0 | 6.8*22*6/7 KCY | 132-15389-00 | 6.8 | 22 | | 6 | 7 |
| FSB0063NB | 6.8*22*7 TC | | 6.8 | 22 | | 7 | |
| FSB0399NB | 7*22*7 SC | | 7 | 22 | | 7 | |
| FSB0335NB | 7*22*7 TC | | 7 | 22 | | 7 | |
| FSB1095NB | 7*22*8 TC | | 7 | 22 | | 8 | |
| FSB0980NB | 8*22*4 SC | | 8 | 22 | | 4 | |
| FSB0978N0 | 8*22*5 VC | | 8 | 22 | | 5 | |
| FSB1111NB | 8*22*6 TC | | 8 | 22 | | 6 | |
| FSB0186NB | 8*22*6.35 TC | | 8 | 22 | | 6.35 | |
| FSB0189NB | 8*22*7 SC | 113LG07 | 8 | 22 | | 7 | |
| FSB0189FB | 8*22*7 SC(VITON) | (FKM) | 8 | 22 | | 7 | |
| FSB0150NB | 8*22*7 TC | | 8 | 22 | | 7 | |
| FSB0150FB | 8*22*7 TC(VITON) | | 8 | 22 | | 7 | |
| FSB0651NB | 8*22*7 TC4 | | 8 | 22 | | 7 | |
| FSB0656NB | 8*22*8 SC | | 8 | 22 | | 8 | |
| FSB1027NB | 8*22*8 TC | | 8 | 22 | | 8 | |
| FSB0161N0 | 8.8*22*6 KC | | 8.8 | 22 | | 6 | |
| FSB0173N0 | 9*22*5 VC | 外徑太小(有研磨外徑) | 9 | 22 | | 5 | |
| FSB0614NB | 9*22*7 SC | 03AT49 | 9 | 22 | | 7 | |
| FSB1086NB | 9*22*7 TC | | 9 | 22 | | 7 | |
| FSB0168N0 | 10*22*4 VC | | 10 | 22 | | 4 | |
| FSB0062NB | 10*22*5 SC | | 10 | 22 | | 5 | |
| FSB0600NB | 10*22*5 TC | | 10 | 22 | | 5 | |
| FSB1074NB | 10*22*6 TC | | 10 | 22 | | 6 | |
| FSB0060NB | 10*22*7 SC | 93101-10002 | 10 | 22 | | 7 | |

| WLK CODE | OIL SEALS | DESCRIPTION | ID | OD1 | OD2 | H1 | H2 |
|-----------|-------------------------------|----------------------|-------|-----|-----|-----|----|
| FSB0060AB | 10*22*7 SC(ACM) Brown | | 10 | 22 | | 7 | |
| FSB0061NB | 10*22*7 TC | | 10 | 22 | | 7 | |
| FSB0061FB | 10*22*7 TC(VITON) | | 10 | 22 | | 7 | |
| FSB0535NB | 10*22*8 SC | 03AT59 | 10 | 22 | | 8 | |
| FSB0217NB | 11*22*7 SC | 90311-11128, 113LG08 | 11 | 22 | | 7 | |
| FSB0075NB | 11*22*7 TC | | 11 | 22 | | 7 | |
| FSB0075FB | 11*22*7 TC(VITON) | | 11 | 22 | | 7 | |
| FSB1070NB | 11*22*8 TC | | 11 | 22 | | 8 | |
| FSB0059NB | 12*22*4 SC | | 12 | 22 | | 4 | |
| FSB0628NB | 12*22*4.5 SC | | 12 | 22 | | 4.5 | |
| FSB0058NB | 12*22*5 SC | DX/DT | 12 | 22 | | 5 | |
| FSB0379NB | 12*22*5 TC | 不排產 | 12 | 22 | | 5 | |
| FSB0379NS | 12*22*5 TC (S304 SPRING) | | 12 | 22 | | 5 | |
| FSB0673NB | 12*22*5.5 TC(BLUE1) | 34-591 | 12 | 22 | | 5.5 | |
| FSB0646NB | 12*22*6 TC | | 12 | 22 | | 6 | |
| FSB0646FB | 12*22*6 TC(VITON) | | 12 | 22 | | 6 | |
| FSB0646QB | 12*22*6 TC(VMQ) | | 12 | 22 | | 6 | |
| FSB0165N0 | 12*22*7 KC | | 12 | 22 | | 7 | |
| FSB0057NB | 12*22*7 SC | 113LG09 | 12 | 22 | | 7 | |
| FSB0231NB | 12*22*7 TB | | 12 | 22 | | 7 | |
| FSB0056NB | 12*22*7 TC | MB100 | 12 | 22 | | 7 | |
| FSB0056NS | 12*22*7 TC (S304SPRING) | SUS304 SPRING | 12 | 22 | | 7 | |
| FSB0056FB | 12*22*7 TC(VITON) | | 12 | 22 | | 7 | |
| FSB0056QB | 12*22*7 TC(VMQ) | | 12 | 22 | | 7 | |
| FSB1002NB | 12*22*8 TC | | 12 | 22 | | 8 | |
| FSB0055NB | 12*22*9 TC | | 12 | 22 | | 9 | |
| FSB1129NB | 12.45*22*6 HSCL | BHH952A,WLK | 12.45 | 22 | | 6 | |
| FSB1128NB | 12.45*22*6 HSCR | | 12.45 | 22 | | 6 | |
| FSB0054NB | 12.5*22*5 SC | | 12.5 | 22 | | 5 | |
| FSB0598NB | 12.5*22*6 TC | | 12.5 | 22 | | 6 | |
| FSB0053NB | 13*22*5 SC | | 13 | 22 | | 5 | |
| FSB0374NB | 13*22*5 TB(TM) | SR400 (SMALL), 038 | 13 | 22 | | 5 | |
| FSB1092NB | 13*22*5.5 TB | | 13 | 22 | | 5.5 | |
| FSB1101NB | 13*22*5.5 TC | | 13 | 22 | | 5.5 | |
| FSB1029NB | 13*22*6 SC | | 13 | 22 | | 6 | |
| FSB0644NB | 13*22*6 TC | F807-18-216 | 13 | 22 | | 6 | |
| FSB0988NB | 13*22*7 TC | | 13 | 22 | | 7 | |
| FSB1031N0 | 14*22*3 VC | | 14 | 22 | | 3 | |
| FSB0524NB | 14*22*4 SC | | 14 | 22 | | 4 | |
| FSB0984NB | 14*22*4 TC | | 14 | 22 | | 4 | |
| FSB0328N0 | 14*22*4 VC | | 14 | 22 | | 4 | |
| FSB0360NS | 14*22*5 SC (SUS) | SUS304 SPRING | 14 | 22 | | 5 | |
| FSB0360FS | 14*22*5 SC (SUS)FKM | SUS304 SPRING (FKM) | 14 | 22 | | 5 | |
| FSB0339NS | 14*22*5 SC (SUS) NSF Approved | SUS304 SPRING (無毒) | 14 | 22 | | 5 | |
| FSB1114NB | 14*22*5 TC | | 14 | 22 | | 5 | |
| FSB1090NB | 14*22*6 TC | | 14 | 22 | | 6 | |
| FSB0302NB | 14*22*7 TC | | 14 | 22 | | 7 | |
| FSA0126N0 | 14.5*22*7 OKC | 90913-14227 | 14.5 | 22 | | 7 | |
| FSB0533N0 | 15*22*4 KB | | 15 | 22 | | 4 | |
| FSB1054NB | 15*22*4 TB | N029-068 | 15 | 22 | | 4 | |
| FSB0365NB | 15*22*4 VB | 90311-15003 | 15 | 22 | | 4 | |
| FSB0052NB | 15*22*5 SC | | 15 | 22 | | 5 | |
| FSB0637NB | 15*22*5 TC | | 15 | 22 | | 5 | |
| FSB1105NB | 15*22*5 TM | | 15 | 22 | | 5 | |
| FSB1094N0 | 15*22*5 VC | | 15 | 22 | | 5 | |
| FSB0160N0 | 15*22*7 KC | | 15 | 22 | | 7 | |
| FSB1106NB | 15*22*7 TC | | 15 | 22 | | 7 | |

| WLK CODE | OIL SEALS | DESCRIPTION | ID | OD1 | OD2 | H1 | H2 |
|-----------|------------------------------------|-------------------------|-------|-------|-----|------|----|
| FSB0616NB | 15.8*22*6 TB(Green) | | 15.8 | 22 | | 6 | |
| FSB0369N0 | 16*22*3 VBY Green | 707150840 | 16 | 22 | | 3 | |
| FSB1032NB | 16*22*3 VC | | 16 | 22 | | 3 | |
| FSB1123NB | 16*22*3 VG | | 16 | 22 | | 3 | |
| FSB0527NB | 16*22*4 SC | | 16 | 22 | | 4 | |
| FSB0630NB | 16*22*4 TC | | 16 | 22 | | 4 | |
| FSB0177N0 | 16*22*5 KC | | 16 | 22 | | 5 | |
| FSB0582NB | 16*22*5 SC | | 16 | 22 | | 5 | |
| FSB1014NB | 16*22*7 TC | | 16 | 22 | | 7 | |
| FSB1016NB | 17*22*5 VC | | 17 | 22 | | 5 | |
| FSB0585FS | 12.5*22.1*7 HSGW(FKM) | SUS304 SPRING(96530172) | 12.5 | 22.1 | | 7 | |
| FSB0585NS | 12.5*22.1*7 HSGW(SUS) NSF Approved | SUS304SPRING&INSERT | 12.5 | 22.1 | | 7 | |
| FSB0095NB | 12.7*22.1*6.35 SC | 0.500*0.870*0.250 SC | 12.7 | 22.1 | | 6.35 | |
| FSB9996NB | 15.75*22.10*2.54 VC | 0.62*0.87*0.10 VC | 15.75 | 22.1 | | 2.54 | |
| FSB0249NB | 12.7*22.17*4.95 SB(BROWN) | 0.500*0.873*0.195 SB | 12.7 | 22.17 | | 4.95 | |
| FSB0051NB | 9.5*22.2*6.3 TC | | 9.5 | 22.2 | | 6.3 | |
| FSB0233NB | 12*22.2*7 TC | | 12 | 22.2 | | 7 | |
| FSB0587FB | 12.7*22.2*7 SC FKM(SUS) | (FKM)SUS304 SPRING | 12.7 | 22.2 | | 7 | |
| FSB0586NS | 12.7*22.2*7 SC(SUS) NSF Approved | SUS304 SPRING (無毒) | 12.7 | 22.2 | | 7 | |
| FSB0250FB | 12.7*22.2*7 TC (FKM)SUS | (FKM) SUS304 SPRING | 12.7 | 22.2 | | 7 | |
| FSB0250NS | 12.7*22.2*7 TC(SUS) NSF Approved | SUS304 SPRING (無毒) | 12.7 | 22.2 | | 7 | |
| FSB9951NB | 7.93*22.22*6.35 SC | | 7.93 | 22.22 | | 6.35 | |
| FSB9971N0 | 12.7*22.22*3.18 VC | | 12.7 | 22.22 | | 3.18 | |
| FSB0251NB | 12.7*22.22*6.35 SC | 0.500*0.875*0.250 SC | 12.7 | 22.22 | | 6.35 | |
| FSB9985NB | 9.53*22.23*6.35 TC | | 9.53 | 22.23 | | 6.35 | |
| FSB9985FB | 9.53*22.23*6.35 TC(FKM) | VITON | 9.53 | 22.23 | | 6.35 | |
| FSB9967NB | 12.7*22.23*4.78 SB | | 12.7 | 22.23 | | 4.78 | |
| FSB1037NB | 12.7*22.23*6.35 SC | | 12.7 | 22.23 | | 6.35 | |
| FSB9980NB | 12.7*22.23*6.35 VB | | 12.7 | 22.23 | | 6.35 | |
| FSB9972NB | 15.88*22.23*3.18 VC | | 15.88 | 22.23 | | 3.18 | |
| FSB0096NB | 9.5*22.3*6.4 SC | 0.374*0.878*0.252 SC | 9.5 | 22.3 | | 6.4 | |
| FSB0110NB | 9.6*22.5*10 SC | | 9.6 | 22.5 | | 10 | |
| FSB0687NB | 12*22.5*5 TC | | 12 | 22.5 | | 5 | |
| FSB0198NB | 12.7*22.50*5.54 TC | 0.500*0.886*0.218 TC | 12.7 | 22.5 | | 5.54 | |
| FSB1020NB | 8*23*5 TC | | 8 | 23 | | 5 | |
| FSB0679NB | 10*23*5 TC | | 10 | 23 | | 5 | |
| FSB0210NB | 10*23*7 TC | | 10 | 23 | | 7 | |
| FSB0983NB | 10*23*8 TC | | 10 | 23 | | 8 | |
| FSB1007NB | 11*23*7 TC | | 11 | 23 | | 7 | |
| FSB1028NB | 12*23*7 TC | | 12 | 23 | | 7 | |
| FSB1009NB | 12*23*8 TC | | 12 | 23 | | 8 | |
| FSB0329NB | 12*23*9 TC3 | | 12 | 23 | | 9 | |
| FSB0391NB | 13*23*7 TC | | 13 | 23 | | 7 | |
| FSB1011NB | 14*23*6 TC | | 14 | 23 | | 6 | |
| FSB0664NB | 15*23*3 KC | | 15 | 23 | | 3 | |
| FSB0647NB | 15*23*3 VC | | 15 | 23 | | 3 | |
| FSB1102NB | 15*23*3 VG | | 15 | 23 | | 3 | |
| FSB0607NB | 15*23*4 TC | | 15 | 23 | | 4 | |
| FSB1121NB | 15*23*5 SC | | 15 | 23 | | 5 | |
| FSB0989NB | 15*23*7 TC | | 15 | 23 | | 7 | |
| FSB0115NB | 16*23*4 SC | | 16 | 23 | | 4 | |
| FSB0986NB | 17*23*3 VC | | 17 | 23 | | 3 | |
| FSB0121NB | 17*23*4 SC | | 17 | 23 | | 4 | |
| FSB1003NB | 12*23.5*8 TC | | 12 | 23.5 | | 8 | |
| FSB0050NB | 15.5*23.6*6 SB | | 15.5 | 23.6 | | 6 | |
| FSB9989NB | 17.46*23.81*3.17 VB | | 17.46 | 23.81 | | 3.17 | |
| FSB9958NB | 15.88*23.83*4.78 TC | | 15.88 | 23.83 | | 4.78 | |

| WLK CODE | OIL SEALS | DESCRIPTION | ID | OD1 | OD2 | H1 | H2 |
|-----------|------------------------------|-------------------|------|-----|-----|-----|-----|
| FSB1076NB | 8*24*7 SC | | 8 | 24 | | 7 | |
| FSB0338NB | 8*24*7 TC | | 8 | 24 | | 7 | |
| FSB0588NB | 9*24*7 TC | | 9 | 24 | | 7 | |
| FSB1116NB | 10*24*4 TC | | 10 | 24 | | 4 | |
| FSB0401NB | 10*24*5 SC | | 10 | 24 | | 5 | |
| FSB0334NB | 10*24*7 SC | | 10 | 24 | | 7 | |
| FSB0341NB | 10*24*7 TC | | 10 | 24 | | 7 | |
| FSB0211NB | 10*24*9.5 TC3 | | 10 | 24 | | 9.5 | |
| FSB0594NB | 10.8*24*6.5 TC(85 Shore) | NBR 85度 | 10.8 | 24 | | 6.5 | |
| FSB0593NB | 10.8*24*6.5/7.5 Y(85 Shore) | NBR 85 度 | 10.8 | 24 | | 6.5 | 7.5 |
| FSB1008NB | 11*24*7 TC | | 11 | 24 | | 7 | |
| FSB0049NB | 11.6*24*10 SC | 91203-001-000 | 11.6 | 24 | | 10 | |
| FSB0219NB | 11.6*24*10 TC(Blue) | | 11.6 | 24 | | 10 | |
| FSB0234NB | 12*24*4.5 SC | | 12 | 24 | | 4.5 | |
| FSB0234NS | 12*24*4.5 SC (S304SPRING | SUS304 SPRING | 12 | 24 | | 4.5 | |
| FSB1055NB | 12*24*4.5 TC | | 12 | 24 | | 4.5 | |
| FSB0196N0 | 12*24*5 KC | | 12 | 24 | | 5 | |
| FSB0590NB | 12*24*5 TC | | 12 | 24 | | 5 | |
| FSB0590FS | 12*24*5 TC(FKM)SUS | SUS304鐵殼+白鐵彈簧 | 12 | 24 | | 5 | |
| FSB0676NB | 12*24*6 TC | | 12 | 24 | | 6 | |
| FSB1112NB | 12*24*6.5 SC | | 12 | 24 | | 6.5 | |
| FSB0254NB | 12*24*7 SC | | 12 | 24 | | 7 | |
| FSB0344NB | 12*24*7 TC | 113LG99 | 12 | 24 | | 7 | |
| FSB0344FB | 12*24*7 TC(VITON) | | 12 | 24 | | 7 | |
| FSB1113NB | 12*24*8 SC | | 12 | 24 | | 8 | |
| FSB1122NB | 13*24*5 SC | | 13 | 24 | | 5 | |
| FSB0048NB | 13*24*6 SC | | 13 | 24 | | 6 | |
| FSB1064NB | 13*24*7 SC | | 13 | 24 | | 7 | |
| FSB0610NB | 13*24*7 TC | | 13 | 24 | | 7 | |
| FSB0631NB | 14*24*4 TC | | 14 | 24 | | 4 | |
| FSB0047NB | 14*24*5 SC | 91202-216-000 | 14 | 24 | | 5 | |
| FSB0998NB | 14*24*5 TC | | 14 | 24 | | 5 | |
| FSB0192N0 | 14*24*6 KC | 93109-14005 RS100 | 14 | 24 | | 6 | |
| FSB0046NB | 14*24*6 TC | | 14 | 24 | | 6 | |
| FSB0046FB | 14*24*6 TC (FKM) | | 14 | 24 | | 6 | |
| FSB0045NB | 14*24*7 TC | | 14 | 24 | | 7 | |
| FSB1045NB | 14*24*7/7.5 TCV(NBR80) | | 14 | 24 | | 7 | 7.5 |
| FSB0520NB | 14*24*8 TC | | 14 | 24 | | 8 | |
| FSB0213NB | 14*24/30*15 Y | | 14 | 24 | 30 | 15 | |
| FSB1062NB | 15*24*4 SC | | 15 | 24 | | 4 | |
| FSB1124NB | 15*24*4.5 TC | | 15 | 24 | | 4.5 | |
| FSB0502NB | 15*24*5 SC(Green) | ECMUSE02 | 15 | 24 | | 5 | |
| FSB0044NB | 15*24*5 TC | E300 . EM500 | 15 | 24 | | 5 | |
| FSB0044FB | 15*24*5 TC(VITON)FKM | VITON | 15 | 24 | | 5 | |
| FSB0044QB | 15*24*5 TC(VMQ) | | 15 | 24 | | 5 | |
| FSB0629NB | 15*24*6 TC | | 15 | 24 | | 6 | |
| FSB0973NB | 15*24*6.5/7 TBV(BLUE) | 38-8266S | 15 | 24 | | 6.5 | 7 |
| FSB0099NB | 15*24*7 DB(Green) | | 15 | 24 | | 7 | |
| FSB0099FB | 15*24*7 DB(VITON) | | 15 | 24 | | 7 | |
| FSB0077NB | 15*24*7 TB(TZ) | | 15 | 24 | | 7 | |
| FSB0043NB | 15*24*7 TC | 113LG41 | 15 | 24 | | 7 | |
| FSB1033N0 | 16*24*3 VG | | 16 | 24 | | 3 | |
| FSB0097NB | 16*24*4 SC | | 16 | 24 | | 4 | |
| FSB0332NB | 16*24*4 TB(TZ) | 92049002 | 16 | 24 | | 4 | |
| FSB0665NB | 16*24*4 TC | | 16 | 24 | | 4 | |
| FSB0159N0 | 16*24*4 VB | | 16 | 24 | | 4 | |
| FSB1091NB | 16*24*4 VC | | 16 | 24 | | 4 | |

| WLK CODE | OIL SEALS | DESCRIPTION | ID | OD1 | OD2 | H1 | H2 |
|-----------|-------------------------------|---------------------|-----|------|-----|------|-----|
| FSB0178N0 | 16*24*5 KB(KM) | | 16 | 24 | | 5 | |
| FSB1135FS | 16*24*5 KC(FKM75) | SUS304 SPRING(FKM) | 16 | 24 | | 5 | |
| FSB0626NB | 16*24*5 SC | | 16 | 24 | | 5 | |
| FSB0368NB | 16*24*6/6.5 TC(Green) | | 16 | 24 | | 6 | 6.5 |
| FSB0370NB | 16*24*7 SB(SM) Green | | 16 | 24 | | 7 | |
| FSB0327NB | 16*24*7 TC | | 16 | 24 | | 7 | |
| FSB0327FB | 16*24*7 TC(VITON) | | 16 | 24 | | 7 | |
| FSB1034N0 | 17*24*3 VC | | 17 | 24 | | 3 | |
| FSB0513NB | 17*24*5 SC | | 17 | 24 | | 5 | |
| FSB0122NB | 17*24*5 TC | | 17 | 24 | | 5 | |
| FSB0653NB | 17*24*5 VB | 90312-17001,NJ745 | 17 | 24 | | 5 | |
| FSB0373NB | 17*24*7 SC | | 17 | 24 | | 7 | |
| FSB0645NB | 17*24*7 TC | | 17 | 24 | | 7 | |
| FSB0633NB | 18*24*3 VG | | 18 | 24 | | 3 | |
| FSB0654NB | 18*24*4 KC | | 18 | 24 | | 4 | |
| FSB0596NB | 18*24*4 TC | | 18 | 24 | | 4 | |
| FSB0596FB | 18*24*4 TC(VITON) | | 18 | 24 | | 4 | |
| FSB1071NB | 18*24*5 SC | | 18 | 24 | | 5 | |
| FSB1068NB | 18*24*7 TC | | 18 | 24 | | 7 | |
| FSB0042NB | 12*24.5*10 SC | | 12 | 24.5 | | 10 | |
| FSB0103NB | 4.8*25*5/5.5 HKCY(R) | RX125 | 4.8 | 25 | | 5 | 5.5 |
| FSB0976NB | 6*25*6 SC | | 6 | 25 | | 6 | |
| FSB0678NB | 8*25*7 TC | | 8 | 25 | | 7 | |
| FSB0041NB | 8*25*8 TC | | 8 | 25 | | 8 | |
| FSB0576NB | 9*25*7 TC | | 9 | 25 | | 7 | |
| FSB1022NB | 9*25*8 SC | | 9 | 25 | | 8 | |
| FSB1069NB | 10*25*5 TC | | 10 | 25 | | 5 | |
| FSB0518NB | 10*25*7 TC | | 10 | 25 | | 7 | |
| FSB0636NB | 11*25*3.5/9.2 Y(NBR85 Shore) | NB04885LT | 11 | 25 | | 3.5 | 9.2 |
| FSB0604NB | 11*25*7 SC | 03AT48 | 11 | 25 | | 7 | |
| FSB0604FB | 11*25*7 SC(VITON)FKM | | 11 | 25 | | 7 | |
| FSB0218NB | 11*25*7 TC | | 11 | 25 | | 7 | |
| FSB0987NB | 11*25*8 TC | | 11 | 25 | | 8 | |
| FSB0040NB | 12*25*4.5 SC | SE01-22-54 | 12 | 25 | | 4.5 | |
| FSB0040FB | 12*25*4.5 SC (FKM)VITON | | 12 | 25 | | 4.5 | |
| FSB0158N0 | 12*25*4.5 VC | | 12 | 25 | | 4.5 | |
| FSB0577NB | 12*25*5 SB | | 12 | 25 | | 5 | |
| FSB0039NB | 12*25*5 SC | | 12 | 25 | | 5 | |
| FSB0039FB | 12*25*5 SC (FKM)VITON | | 12 | 25 | | 5 | |
| FSB0039NS | 12*25*5 SC (S304SPRING) | SUS304 SPRING | 12 | 25 | | 5 | |
| FSB0039QB | 12*25*5 SC (VMQ) | | 12 | 25 | | 5 | |
| FSB0039QS | 12*25*5 SC (VMQ)(S304SPR | (VMQ) SUS304 SPRING | 12 | 25 | | 5 | |
| FSB0238NB | 12*25*5 TC | | 12 | 25 | | 5 | |
| FSB0238FB | 12*25*5 TC(VITON)FKM | | 12 | 25 | | 5 | |
| FSB0195Q0 | 12*25*6 KC6 (VMQ) | | 12 | 25 | | 6 | |
| FSB1044NB | 12*25*6 TB | | 12 | 25 | | 6 | |
| FSB1089NB | 12*25*6 TC | | 12 | 25 | | 6 | |
| FSB1048NB | 12*25*7 TB | | 12 | 25 | | 7 | |
| FSB0038NB | 12*25*7 TC | SE01-22-57 | 12 | 25 | | 7 | |
| FSB0996NB | 12*25*7 TC(ID-1.5mm)NBR | AP0382E | 12 | 25 | | 7 | |
| FSB0079NB | 12*25*8 TC | | 12 | 25 | | 8 | |
| FSB0089NB | 13*25*4.5 TC | | 13 | 25 | | 4.5 | |
| FSB1058NB | 13*25*5 TC | | 13 | 25 | | 5 | |
| FSB0256NB | 13*25*7 TB | 90311-13050 | 13 | 25 | | 7 | |
| FSB0037NB | 13*25*7 TC | | 13 | 25 | | 7 | |
| FSB0259NB | 13*25*12.7 TC3Y | | 13 | 25 | | 12.7 | |
| FSB0092NB | 14*25*5 SC | 93104-14059 | 14 | 25 | | 5 | |

| WLK CODE | OIL SEALS | DESCRIPTION | ID | OD1 | OD2 | H1 | H2 |
|-----------|-------------------------------|------------------------|-------|-------|-----|-------|----|
| FSB0561NS | 14*25*5 SC (S304SPRING) | 白鐵發條 | 14 | 25 | | 5 | |
| FSB0092FS | 14*25*5 SC (SUS)FKM | SUS304 SPRING (FKM) | 14 | 25 | | 5 | |
| FSB0362NS | 14*25*5 SC (SUS) NSF Approval | SUS304 SPRING (無毒) | 14 | 25 | | 5 | |
| FSB0526NS | 14*25*5 SC (SUS) | SUS304 SPRING | 14 | 25 | | 5 | |
| FSB0155NS | 14*25*5 TC (S304 SPRING) | | 14 | 25 | | 5 | |
| FSB0155FS | 14*25*5 TC VITON(S304) | | 14 | 25 | | 5 | |
| FSB0157N0 | 14*25*5 VC | | 14 | 25 | | 5 | |
| FSB0036NB | 14*25*6 SC | | 14 | 25 | | 6 | |
| FSB0035NB | 14*25*7 TB | 653G142507 KICK SHAFT | 14 | 25 | | 7 | |
| FSB0098NB | 14*25*7 TC | | 14 | 25 | | 7 | |
| FSB0098FB | 14*25*7 TC(VITON) | | 14 | 25 | | 7 | |
| FSB0677NB | 14*25/26/35*19 TC5F | 09289-14001 | 14 | 25 | 26 | 19 | |
| FSB0174N0 | 15*25*3.7 VB | 穩力專用 | 15 | 25 | | 3.7 | |
| FSB0034NB | 15*25*4 SC | | 15 | 25 | | 4 | |
| FSB0101NB | 15*25*4 VB | | 15 | 25 | | 4 | |
| FSB0033NB | 15*25*5 SC | | 15 | 25 | | 5 | |
| FSB0001FB | 15*25*5 SC (FKM)VITON | | 15 | 25 | | 5 | |
| FSB1005NB | 15*25*5 TG | 34-284 | 15 | 25 | | 5 | |
| FSB0032NB | 15*25*6 TC | 92049-2076 | 15 | 25 | | 6 | |
| FSB0100NB | 15*25*7 TB (TZ) | 90311-15001 | 15 | 25 | | 7 | |
| FSB0031NB | 15*25*7 TC | 90311-15002;090901032 | 15 | 25 | | 7 | |
| FSB0031FB | 15*25*7 TC (FKM)VITON | | 15 | 25 | | 7 | |
| FSB0090NB | 16*25*5 TC | | 16 | 25 | | 5 | |
| FSB1103NB | 16*25*6 TC | | 16 | 25 | | 6 | |
| FSB0087NB | 16*25*7 TC | | 16 | 25 | | 7 | |
| FSB1035N0 | 17*25*3 KC | | 17 | 25 | | 3 | |
| FSB0030NB | 17*25*4 SC | 93101-17062 | 17 | 25 | | 4 | |
| FSB0069NB | 17*25*4 TC | | 17 | 25 | | 4 | |
| FSB1042NB | 17*25*6 TC | | 17 | 25 | | 6 | |
| FSB1042FB | 17*25*6 TC(VITON) | | 17 | 25 | | 6 | |
| FSB0669NB | 17*25*7 TC | | 17 | 25 | | 7 | |
| FSB1063N0 | 18*25*5 VC | | 18 | 25 | | 5 | |
| FSB0990NB | 18*25*7 TC | | 18 | 25 | | 7 | |
| FSB1049NB | 19*25*6 TC | | 19 | 25 | | 6 | |
| FSB0568N0 | 19.05*25*3.18 VB(VM) | | 19.05 | 25 | | 3.18 | |
| FSB9991NB | 15.88*25.38*6.35 TB | | 15.88 | 25.38 | | 6.35 | |
| FSB9942NB | 9.53*25.4*6.35 SC | | 9.53 | 25.4 | | 6.35 | |
| FSB9969NB | 11.11*25.4*6.35 SC | | 11.11 | 25.4 | | 6.35 | |
| FSB0029NB | 11.91*25.4*7.92 TC4 | 0.469*1.000*0.312 TC4 | 11.91 | 25.4 | | 7.92 | |
| FSB0529NB | 12.7*25.4*6.35 SB | 0.500*1.000*0.250 SB | 12.7 | 25.4 | | 6.35 | |
| FSB9964NB | 12.7*25.4*6.35 TB | | 12.7 | 25.4 | | 6.35 | |
| FSB0562NB | 12.7*25.4*6.35 TC | | 12.7 | 25.4 | | 6.35 | |
| FSB9977NB | 12.7*25.4*7.93 SC | | 12.7 | 25.4 | | 7.93 | |
| FSB9976NB | 12.7*25.4*7.93 TC | | 12.7 | 25.4 | | 7.93 | |
| FSB0143NB | 13.58*25.4*6.35 TB | 0.535*1.000*0.250 TB | 13.58 | 25.4 | | 6.35 | |
| FSB9987NB | 14.28*25.4*6.35 SC | | 14.28 | 25.4 | | 6.35 | |
| FSB9959NB | 14.3*25.4*6.35 TC | | 14.3 | 25.4 | | 6.35 | |
| FSB0197NB | 15*25.4*5/7 TCY | | 15 | 25.4 | | 5 | 7 |
| FSB0028NB | 15*25.4*7 TC | | 15 | 25.4 | | 7 | |
| FSB0113NB | 15.54*25.4*6.35 TB | 0.612*1.000*0.250 TB | 15.54 | 25.4 | | 6.35 | |
| FSB0114NB | 15.58*25.4*6.35 TB | 0.613*1.000*0.250 TB | 15.58 | 25.4 | | 6.35 | |
| FSB0027NB | 15.87*25.4*6.35 SC | 0.625*1.000*0.250 SC | 15.87 | 25.4 | | 6.35 | |
| FSB0501NO | 15.88*25.4*3.175 VZ(VB) | 0.625*1.000*0.125 VZ紫色 | 15.88 | 25.4 | | 3.175 | |
| FSB9962NB | 15.88*25.4*4.76 SC | | 15.88 | 25.4 | | 4.76 | |
| FSB9957NB | 15.88*25.4*6.35 SC | | 15.88 | 25.4 | | 6.35 | |
| FSB9986NB | 15.88*25.4*6.35 TB | | 15.88 | 25.4 | | 6.35 | |
| FSB9986FB | 15.88*25.4*6.35 TB(FKM) | VITON | 15.88 | 25.4 | | 6.35 | |

| WLK CODE | OIL SEALS | DESCRIPTION | ID | OD1 | OD2 | H1 | H2 |
|-----------|---------------------------|--------------------------|-------|------|-----|------|------|
| FSB9979NB | 15.88*25.4*6.35 TC | | 15.88 | 25.4 | | 6.35 | |
| FSB9979FB | 15.88*25.4*6.35 TC(VITON) | | 15.88 | 25.4 | | 6.35 | |
| FSB0522NB | 15.88*25.4*6.4 TC | | 15.88 | 25.4 | | 6.4 | |
| FSB9947NB | 15.88*25.4*7.95/9.53TC6Y | LMB-002/721-0355 | 15.88 | 25.4 | | 7.95 | 9.53 |
| FSB0185N0 | 19.05*25.4*3.18 VB(VM) | 0.750*1.000*0.125 VB(VM) | 19.05 | 25.4 | | 3.18 | |
| FSB9952NB | 19.05*25.4*3.96 SB | | 19.05 | 25.4 | | 3.96 | |
| FSB0979N0 | 19.05*25.4*3.96 VC | | 19.05 | 25.4 | | 3.96 | |
| FSB9950NB | 19.05*25.4*4.78 SC | | 19.05 | 25.4 | | 4.78 | |
| FSB9943NB | 19.05*25.4*6.35 TC | | 19.05 | 25.4 | | 6.35 | |
| FSB9997NB | 19.05*25.4*6.35 VB | 0.750*1.000*0.250 VB | 19.05 | 25.4 | | 6.35 | |
| FSB0104NB | 15*25.5*7 TC | | 15 | 25.5 | | 7 | |
| FSB0199NB | 15.6*25.5*7 TC Green | SV50 | 15.6 | 25.5 | | 7 | |
| FSB0156N0 | 4.5*26*8 KC | | 4.5 | 26 | | 8 | |
| FSB1021NB | 8*26*7 TC | | 8 | 26 | | 7 | |
| FSB0167N0 | 10*26*5 VC | | 10 | 26 | | 5 | |
| FSB0212NB | 10*26*7 TC | | 10 | 26 | | 7 | |
| FSB0970NB | 11*26*7 SC | | 11 | 26 | | 7 | |
| FSB0638NB | 11*26*7 TC | | 11 | 26 | | 7 | |
| FSB0026NB | 12*26*4.5 TC | | 12 | 26 | | 4.5 | |
| FSB0026NS | 12*26*4.5 TC (S304SPRING) | | 12 | 26 | | 4.5 | |
| FSB0194N0 | 12*26*5 VC | | 12 | 26 | | 5 | |
| FSB0242NB | 12*26*7 TC | | 12 | 26 | | 7 | |
| FSB0605NB | 12*26*7 TCV | | 12 | 26 | | 7 | |
| FSB0025NB | 13*26*4 SC | | 13 | 26 | | 4 | |
| FSB1097NB | 13*26*5 SC | | 13 | 26 | | 5 | |
| FSB0261NB | 13*26*7 TC | | 13 | 26 | | 7 | |
| FSB1088NB | 13*26*8 TC | | 13 | 26 | | 8 | |
| FSB0567NB | 13*26*9 TC | | 13 | 26 | | 9 | |
| FSB1047NB | 14*26*5 TB | | 14 | 26 | | 5 | |
| FSB0648NB | 14*26*6 TC | | 14 | 26 | | 6 | |
| FSB0024NB | 14*26*7 TC | | 14 | 26 | | 7 | |
| FSB0612N0 | 14*26*12 Y | BR2227E | 14 | 26 | | 12 | |
| FSA0013NB | 14*26*13 TC69 | | 14 | 26 | | 13 | |
| FSB0611NS | 15*26*3.7/4.5 TMY(S304) | NBR90度 | 15 | 26 | | 3.7 | 4.5 |
| FSB1052NB | 15*26*4 TB | N029-076 | 15 | 26 | | 4 | |
| FSB1041NB | 15*26*4.5 TC | | 15 | 26 | | 4.5 | |
| FSB0584NB | 15*26*5 TB | | 15 | 26 | | 5 | |
| FSB0105NB | 15*26*5 TC | | 15 | 26 | | 5 | |
| FSB0105N0 | 15*26*5 TC w/o spring | | 15 | 26 | | 5 | |
| FSB0971NB | 15*26*5.5/6.5 TBV(BLUE) | 38-2377 | 15 | 26 | | 5.5 | 6.5 |
| FSB0106NB | 15*26*6 SC | | 15 | 26 | | 6 | |
| FSB0534NB | 15*26*6 TB(TM) | | 15 | 26 | | 6 | |
| FSB0023NB | 15*26*6 TC | | 15 | 26 | | 6 | |
| FSB0972FB | 15*26*6.5/7 TBV(VITON) | 38-8266B | 15 | 26 | | 6.5 | 7 |
| FSB0615NB | 15*26*7 DB | Green; Black | 15 | 26 | | 7 | |
| FSB0078NB | 15*26*7 TC | | 15 | 26 | | 7 | |
| FSB1025NB | 15*26*9 TC | | 15 | 26 | | 9 | |
| FSB0116NB | 16*26*5 TB | | 16 | 26 | | 5 | |
| FSB1085N0 | 16*26*5 VB | | 16 | 26 | | 5 | |
| FSB0571N0 | 16*26*5/7 TDKI | | 16 | 26 | | 5 | 7 |
| FSB0022NB | 16*26*6 SC | | 16 | 26 | | 6 | |
| FSB0117NB | 16*26*6 TC | | 16 | 26 | | 6 | |
| FSB0570NB | 16*26*7 TB | | 16 | 26 | | 7 | |
| FSB0118NB | 16*26*7 TC | | 16 | 26 | | 7 | |
| FSB0532NB | 16*26*8 TC | | 16 | 26 | | 8 | |
| FSB0625NB | 17*26*4 SC | | 17 | 26 | | 4 | |
| FSB0977NB | 17*26*4.5 TC | | 17 | 26 | | 4.5 | |

| WLK CODE | OIL SEALS | DESCRIPTION | ID | OD1 | OD2 | H1 | H2 |
|-----------|----------------------------|---------------------------|-------|-------|-------|------|------|
| FSB0149NB | 17*26*6 TB | | 17 | 26 | | 6 | |
| FSB0658NB | 17*26*6 TC | | 17 | 26 | | 6 | |
| FSB0531NB | 17*26*7 TC | | 17 | 26 | | 7 | |
| FSB0181N0 | 18*26*4 VB(VZ) | | 18 | 26 | | 4 | |
| FSB1084NB | 18*26*4 VC | | 18 | 26 | | 4 | |
| FSB0621N0 | 18*26*4 VG | | 18 | 26 | | 4 | |
| FSB0574NB | 18*26*4.5 TC | | 18 | 26 | | 4.5 | |
| FSB0135NB | 18*26*6 TB | | 18 | 26 | | 6 | |
| FSB0511NB | 18*26*6 TC | | 18 | 26 | | 6 | |
| FSB0517NB | 18*26*7 TC | | 18 | 26 | | 7 | |
| FSB0020NB | 20*26*4 SB(SZ) GREEN | 707-1508-OS | 20 | 26 | | 4 | |
| FSB1061NB | 20*26*4 TC | | 20 | 26 | | 4 | |
| FSB0172F0 | 20*26*4 VC(VITON) | | 20 | 26 | | 4 | |
| FSB0992NB | 20*26*5 TC | | 20 | 26 | | 5 | |
| FSB0579NB | 20*26*6 SB | | 20 | 26 | | 6 | |
| FSB0191N0 | 21*26*4 VB | | 21 | 26 | | 4 | |
| FSB0578NB | 18.3*26.1*3.5 TC(N701) | NBR N701 | 18.3 | 26.1 | | 3.5 | |
| FSB0137NB | 7*26.2*5.5 TC Blue | | 7 | 26.2 | | 5.5 | |
| FSB1053NB | 18.4*26.4*3.6 TB | N029-077 | 18.4 | 26.4 | | 3.6 | |
| FSC0507N0 | 5*26.5/31.5*8 Y軟 | 113LG143 | 5 | 26.5 | 31.5 | 8 | |
| FSB1108NB | 10*27*7 TC | | 10 | 27 | | 7 | |
| FSB0346NB | 12*27*7 TC | | 12 | 27 | | 7 | |
| FSB0523NB | 12*27*9 TC | | 12 | 27 | | 9 | |
| FSB1080NB | 13*27*7 TC | | 13 | 27 | | 7 | |
| FSB0995NB | 13*27*8 TC | | 13 | 27 | | 8 | |
| FSB0351NB | 14*27*7 TC | | 14 | 27 | | 7 | |
| FSB0108NB | 15*27*6 TC | | 15 | 27 | | 6 | |
| FSB0352NB | 15*27*7 TC | 9283-15277 | 15 | 27 | | 7 | |
| FSB1078NB | 16*27*6 TC | | 16 | 27 | | 6 | |
| FSB1015NB | 16*27*7 TC | | 16 | 27 | | 7 | |
| FSB0017NB | 16.99*27.00*7.14 SC | 0.669*1.063*0.281 SC | 16.99 | 27 | | 7.14 | |
| FSB0652NB | 17*27*6 SC | | 17 | 27 | | 6 | |
| FSB0336NB | 17*27*6 TC | | 17 | 27 | | 6 | |
| FSB0394NB | 17*27*6 TG | | 17 | 27 | | 6 | |
| FSB0655NB | 17*27*7 TC | | 17 | 27 | | 7 | |
| FSB0400NB | 17*27*8 TC | | 17 | 27 | | 8 | |
| FSB0682NB | 17*27*10 TC | | 17 | 27 | | 10 | |
| FSB0623NB | 17*27/33*10.3 KC45Y | 32867-E3200 | 17 | 27 | 33 | 10.3 | |
| FSB0019NB | 18*27*5 SC | | 18 | 27 | | 5 | |
| FSB0589NB | 18*27*7 TC | | 18 | 27 | | 7 | |
| FSB1100NB | 19*27*4 VG | | 19 | 27 | | 4 | |
| FSB0018NB | 19*27*5 TC | | 19 | 27 | | 5 | |
| FSB0627NB | 19*27*6 TC | | 19 | 27 | | 6 | |
| FSB0982NB | 20*27*5 SC | | 20 | 27 | | 5 | |
| FSB1057NB | 20*27*5 TC | | 20 | 27 | | 5 | |
| FSB0187N0 | 20*27*5 VB(VM) | | 20 | 27 | | 5 | |
| FSB0016NB | 9*27.2*10 TC | | 9 | 27.2 | | 10 | |
| FSC9960NB | 17.86*27.79/34.92*4.37/6 | 18*34.7*4/6.4 TC5Y(NBR90) | 17.86 | 27.79 | 34.92 | 4.37 | 6.76 |
| FSB9963N0 | 19.84*27.79*6.35 KC | | 19.84 | 27.79 | | 6.35 | |
| FSB9961NB | 16.28*27.98*5.16 TM | 34-261 | 16.28 | 27.98 | | 5.16 | |
| FSE0508N0 | 6*28/54.5*10.2 Y(PVC+Felt) | 加0.5mmPVC板及白羊毛墊 | 6 | 28 | 54.5 | 10.2 | |
| FSB0671NB | 10*28*7 SC | | 10 | 28 | | 7 | |
| FSB0072NB | 10*28*7 TC | | 10 | 28 | | 7 | |
| FSB0214NB | 10*28*10 TC | | 10 | 28 | | 10 | |
| FSB0252NB | 11.8*28*7.5/9 Y(TCA) | | 11.8 | 28 | | 7.5 | 9 |
| FSB1119NB | 12*28*4 TC | | 12 | 28 | | 4 | |
| FSB0151NB | 12*28*5 SC | | 12 | 28 | | 5 | |

| WLK CODE | OIL SEALS | DESCRIPTION | ID | OD1 | OD2 | H1 | H2 |
|------------|----------------------------|-------------------------|------|-----|-----|-----|-----|
| FSB1077NB | 12*28*5 TC | | 12 | 28 | | 5 | |
| FSB0675NB | 12*28*5.5 TC(BLUE1) | 34-594 | 12 | 28 | | 5.5 | |
| FSB1067NB | 12*28*6 TC | | 12 | 28 | | 6 | |
| FSB0093NB | 12*28*7 DCA | DC+鐵殼 | 12 | 28 | | 7 | |
| FSB0205NB | 12*28*7 SBP Green Painting | RAL6016 | 12 | 28 | | 7 | |
| FSB0245NB | 12*28*7 TB(TZ) | | 12 | 28 | | 7 | |
| FSB0015NB | 12*28*7 TC | | 12 | 28 | | 7 | |
| FSB0073NB | 12*28*7 TC (SPECIAL) | 外徑28.08+-0.02特材806 | 12 | 28 | | 7 | |
| FSB1043NB | 12*28*8 SC | | 12 | 28 | | 8 | |
| FSB0071NB | 13*28*6 TC | | 13 | 28 | | 6 | |
| FSB0510NB | 13*28*7 SC | | 13 | 28 | | 7 | |
| FSB0595NB | 13*28*7 TC | | 13 | 28 | | 7 | |
| FSB1098NB | 14*28*5 TC | | 14 | 28 | | 5 | |
| FSB0389NS | 14*28*6 TC (S304SPRING) | | 14 | 28 | | 6 | |
| FSB0389NSS | 14*28*6 TC(S304+INSERT) | SUS304 SPRING(SUS304鐵殼) | 14 | 28 | | 6 | |
| FSB0013NB | 14*28*7 TC | | 14 | 28 | | 7 | |
| FSB0013NS | 14*28*7 TC(S304 SPRING) | | 14 | 28 | | 7 | |
| FSB1120NB | 14*28*8 TC | | 14 | 28 | | 8 | |
| FSB1093NB | 14*28*10 SC | | 14 | 28 | | 10 | |
| FSB0080NB | 14*28*10 TC | | 14 | 28 | | 10 | |
| FSB0597NB | 15*28*4 SC | | 15 | 28 | | 4 | |
| FSB0674NB | 15*28*4.5/5 TBY(BLUE1) | | 15 | 28 | | 4.5 | 5 |
| FSB1133NB | 15*28*5 SC | | 15 | 28 | | 5 | |
| FSB0974NB | 15*28*5 TC | | 15 | 28 | | 5 | |
| FSB0012NB | 15*28*6 SC | | 15 | 28 | | 6 | |
| FSB0012FB | 15*28*6 SC (FKM)VITON | 70 SHORE | 15 | 28 | | 6 | |
| FSB0109NB | 15*28*6 TC | | 15 | 28 | | 6 | |
| FSB1079NB | 15*28*7 TB | | 15 | 28 | | 7 | |
| FSB0085NB | 15*28*7 TC | | 15 | 28 | | 7 | |
| FSB0085QS | 15*28*7 TC (VMQ)S304SPRI | S304 SPRING | 15 | 28 | | 7 | |
| FSB0624NB | 15*28*7 TCAY | | 15 | 28 | | 7 | |
| FSB0011NB | 16*28*5.5/6.5 TC3Y | | 16 | 28 | | 5.5 | 6.5 |
| FSB0153N0 | 16*28*6 KCCY | | 16 | 28 | | 6 | |
| FSB0333FB | 16*28*7 SC(VITON) | TC修掉副唇 | 16 | 28 | | 7 | |
| FSB0010NB | 16*28*7 TC | 91204-259-00-3 | 16 | 28 | | 7 | |
| FSB0010FB | 16*28*7 TC(VITON) | | 16 | 28 | | 7 | |
| FSB0082NB | 16*28*7/13 HSC | | 16 | 28 | | 7 | 13 |
| FSB0009NB | 16.8*28*5 SC | | 16.8 | 28 | | 5 | |
| FSB0008NB | 16.9*28*5 SC | | 16.9 | 28 | | 5 | |
| FSB0145NB | 17*28*5 SC | 478-1508-40(Green) | 17 | 28 | | 5 | |
| FSB0378NB | 17*28*5 TB (TZ) | | 17 | 28 | | 5 | |
| FSB0581NB | 17*28/32*5.5 HTC5L | 93102-17264 | 17 | 28 | 32 | 5.5 | |
| FSB0152AB | 17*28*6 SC (ACM) | | 17 | 28 | | 6 | |
| FSB0274FB | 17*28*6 SC (FKM)VITON | | 17 | 28 | | 6 | |
| FSB0086NB | 17*28*6 TB(TM) | | 17 | 28 | | 6 | |
| FSB0125NB | 17*28*6 TC | | 17 | 28 | | 6 | |
| FSB0124PB | 17*28*6 TCJ (PTFE) | | 17 | 28 | | 6 | |
| FSB0603NB | 17*28*6 TZ | ID-1.5mm | 17 | 28 | | 6 | |
| FSB0371NB | 17*28*6.5 DBC Green | | 17 | 28 | | 6.5 | |
| FSB0371FB | 17*28*6.5 DBC(FKM)VITON | | 17 | 28 | | 6.5 | |
| FSB0127NB | 17*28*7 DB(Green) | 7071508OS | 17 | 28 | | 7 | |
| FSB0127FB | 17*28*7 DB(VITON)FKM | | 17 | 28 | | 7 | |
| FSB0253NB | 17*28*7 HTCR | 15639-012-0 | 17 | 28 | | 7 | |
| FSB0084NB | 17*28*7 SB(SZ) | | 17 | 28 | | 7 | |
| FSB0123NB | 17*28*7 SC | 113LG42 | 17 | 28 | | 7 | |
| FSB0007NB | 17*28*7 TC | MD-009038;MD-069948 | 17 | 28 | | 7 | |
| FSB0007QB | 17*28*7 TC (VMQ) | | 17 | 28 | | 7 | |

| WLK CODE | OIL SEALS | DESCRIPTION | ID | OD1 | OD2 | H1 | H2 |
|------------|---|----------------------|-------|--------|-----|------|------|
| FSB0007FB | 17*28*7 TC(VITON) | | 17 | 28 | | 7 | |
| FSB0126NB | 17*28*7 TZ(TB) | | 17 | 28 | | 7 | |
| FSB0566NB | 17*28*7.3 TGB | DT172871 | 17 | 28 | | 7.3 | |
| FSB0642NB | 17*28*8 DB | | 17 | 28 | | 8 | |
| FSB0128NB | 17*28*8 DC | | 17 | 28 | | 8 | |
| FSB0686NB | 17*28*8 TC | | 17 | 28 | | 8 | |
| FSB1115NB | 18*28*4 SC | | 18 | 28 | | 4 | |
| FSB1056NB | 18*28*4 TC | | 18 | 28 | | 4 | |
| FSB0006NB | 18*28*6 SC | | 18 | 28 | | 6 | |
| FSB0525NB | 18*28*6 TC | | 18 | 28 | | 6 | |
| FSB1109FB | 18*28*7 SC(VITON) | | 18 | 28 | | 7 | |
| FSB0136NB | 18*28*7 TC | 456-1508-00綠色 | 18 | 28 | | 7 | |
| FSB0136FB | 18*28*7 TC(VITON) | | 18 | 28 | | 7 | |
| FSB1117NB | 18*28*8 TC | | 18 | 28 | | 8 | |
| FSB0139NB | 18.9*28*5 SC | | 18.9 | 28 | | 5 | |
| FSB0003NB | 19*28*6 TC3 | | 19 | 28 | | 6 | |
| FSB0141NB | 19*28*7 TC | | 19 | 28 | | 7 | |
| FSB0632NB | 20*28*4 SC | | 20 | 28 | | 4 | |
| FSB0575NB | 20*28*4 TC | | 20 | 28 | | 4 | |
| FSB0188N0 | 20*28*4 VB | | 20 | 28 | | 4 | |
| FSB0622NB | 20*28*5 TC | | 20 | 28 | | 5 | |
| FSB0609NB | 20*28*6 SM(Green) | | 20 | 28 | | 6 | |
| FSB0262NB | 20*28*6 TC | | 20 | 28 | | 6 | |
| FSB0528NB | 20*28*7 TC | | 20 | 28 | | 7 | |
| FSB0528FB | 20*28*7 TC(VITON) | | 20 | 28 | | 7 | |
| FSB0166N0 | 22*28*4 VC | | 22 | 28 | | 4 | |
| FSB1118NB | 22*28*8 TC | | 22 | 28 | | 8 | |
| FSB1126NB | 12*28.5*7 TC | | 12 | 28.5 | | 7 | |
| FSB0564NB | 12.7*28.5*6.35 TB | | 12.7 | 28.5 | | 6.35 | |
| FSB0111NB | 15*28.5*6.3 SC | | 15 | 28.5 | | 6.3 | |
| FSB0005NB | 17*28.5*6 SC Blue | | 17 | 28.5 | | 6 | |
| FSB9999NB | 12.7*28.55*6.4 SC | 0.500*1.124*0.252 SC | 12.7 | 28.55 | | 6.4 | |
| FSB9994NB | 19.05*28.575*6.35 TC | 0.750*1.125*0.250 TC | 19.05 | 28.575 | | 6.35 | |
| FSB9988NB | 12.7*28.58*6.35 TB | | 12.7 | 28.58 | | 6.35 | |
| FSB9988FB | 12.7*28.58*6.35 TB(VITON) | | 12.7 | 28.58 | | 6.35 | |
| FSB9960NB | 12.7*28.58*6.35 TC | | 12.7 | 28.58 | | 6.35 | |
| FSB1082AB | 12.7*28.58*7.14 SBP(ACM) Green Painting | 5497 Pol | 12.7 | 28.58 | | 7.14 | |
| FSB1082NB | 12.7*28.58*7.14 SBP Green Painting | | 12.7 | 28.58 | | 7.14 | |
| FSB0521NB | 12.7*28.58*7.9 TC | | 12.7 | 28.58 | | 7.9 | |
| FSB0591NSS | 12.7*28.58*7.92/9.93 TBY | 白鐵彈簧+鐵殼 | 12.7 | 28.58 | | 7.92 | 9.93 |
| FSB9965NB | 12.7*28.58*7.95 SC | | 12.7 | 28.58 | | 7.95 | |
| FSB9953NB | 12.7*28.58*7.95 TC | | 12.7 | 28.58 | | 7.95 | |
| FSB9946NB | 14.3*28.58*6.35 TB | | 14.3 | 28.58 | | 6.35 | |
| FSB1036NB | 14.3*28.58*6.35 TC | | 14.3 | 28.58 | | 6.35 | |
| FSB9954NB | 14.36*28.58*6.35 TC | | 14.36 | 28.58 | | 6.35 | |
| FSB9966NB | 15.88*28.58*6.35 SB | | 15.88 | 28.58 | | 6.35 | |
| FSB9966FB | 15.88*28.58*6.35 SB(VITO) | VITON(FKM) | 15.88 | 28.58 | | 6.35 | |
| FSB9990NB | 15.88*28.58*6.35 SC | | 15.88 | 28.58 | | 6.35 | |
| FSB0592NB | 15.88*28.58*6.35 TB | | 15.88 | 28.58 | | 6.35 | |
| FSB0563NB | 15.88*28.58*6.35 TC | | 15.88 | 28.58 | | 6.35 | |
| FSB9975NB | 15.88*28.58*6.35 VB | | 15.88 | 28.58 | | 6.35 | |
| FSB0366NB | 15.88*28.58*6.4 TC | 0.625*1.125*0.252 TC | 15.88 | 28.58 | | 6.4 | |
| FSC9922NB | 15.88*28.58*7.93 TC | | 15.88 | 28.58 | | 7.93 | |
| FSB9998NB | 15.88*28.58*7.95 DC | | 15.88 | 28.58 | | 7.95 | |
| FSB9995NB | 15.88*28.58*9.53 TB | 0.625*1.125*0.375 TB | 15.88 | 28.58 | | 9.53 | |
| FSB9970NB | 15.88*28.58*9.53 TC | | 15.88 | 28.58 | | 9.53 | |
| FSB9970FB | 15.88*28.58*9.53 TC(FKM) | VIOTN | 15.88 | 28.58 | | 9.53 | |

| WLK CODE | OIL SEALS | DESCRIPTION | ID | OD1 | OD2 | H1 | H2 |
|-----------|---------------------------------|----------------------|-------|-------|-----|------|------|
| FSB0364NB | 16*28.58*7 DC | | 16 | 28.58 | | 7 | |
| FSB9981NB | 16.66*28.58*7.95 DC | 0.656*1.125*0.313 DC | 16.66 | 28.58 | | 7.95 | |
| FSB1104NB | 17*28.58*7 DC | | 17 | 28.58 | | 7 | |
| FSB0512NB | 17.46*28.58*6.35 SC | | 17.46 | 28.58 | | 6.35 | |
| FSB9955NB | 17.48*28.58*6.35 SB | | 17.48 | 28.58 | | 6.35 | |
| FSB9968NB | 17.48*28.58*6.35 SC | | 17.48 | 28.58 | | 6.35 | |
| FSB9992NB | 17.48*28.58*6.35 TC | 0.688*1.125*0.250 TC | 17.48 | 28.58 | | 6.35 | |
| FSB9993NB | 17.48*28.58*7.95 DC | | 17.48 | 28.58 | | 7.95 | |
| FSB0969NB | 17.48*28.58*7.95 TB | | 17.48 | 28.58 | | 7.95 | |
| FSB9982NB | 17.48*28.58*7.95 TC | | 17.48 | 28.58 | | 7.95 | |
| FSB9978NB | 19.05*28.58*3.96 VC | | 19.05 | 28.58 | | 3.96 | |
| FSB9974NB | 19.05*28.58*4.78 SB | | 19.05 | 28.58 | | 4.78 | |
| FSB9973NB | 19.05*28.58*6.35 TC | 0.750*1.125*0.25 TC | 19.05 | 28.58 | | 6.35 | |
| FSB0357NB | 19.05*28.58*6.4 TC | 0.750*1.125*0.252 TC | 19.05 | 28.58 | | 6.4 | |
| FSB9984NB | 22.23*28.58*3.18 VB | | 22.23 | 28.58 | | 3.18 | |
| FSB0094NB | 14*28.6*7 TC | | 14 | 28.6 | | 7 | |
| FSB0074NB | 15*28.6*7 TC | | 15 | 28.6 | | 7 | |
| FSB0004NB | 15.8*28.6*6.3 TC | 0.625*1.125*0.250 TC | 15.8 | 28.6 | | 6.3 | |
| FSB0148NB | 16.5*28.6*9.5 SA | | 16.5 | 28.6 | | 9.5 | |
| FSB0130NB | 17*28.6*7 TC | | 17 | 28.6 | | 7 | |
| FSB0076NB | 19.2*28.6*7 TC | | 19.2 | 28.6 | | 7 | |
| FSB0345NB | 16*28.65*6.5 TC | | 16 | 28.65 | | 6.5 | |
| FSB0142NB | 17*28.7*9.5 SA | | 17 | 28.7 | | 9.5 | |
| FSB0337NB | 17.5*28.77*6.3 SC | 0.687*1.125*0.250 SC | 17.5 | 28.77 | | 6.3 | |
| FSB1023NB | 9*29*7 TC | | 9 | 29 | | 7 | |
| FSB1012NB | 14*29*7 TC | | 14 | 29 | | 7 | |
| FSB0572NB | 15*29*7 TC | | 15 | 29 | | 7 | |
| FSB0608NB | 16*29*7 TC | | 16 | 29 | | 7 | |
| FSB0002NB | 17*29*5 SC | 91203-035-000 | 17 | 29 | | 5 | |
| FSB0670NB | 17*29*5 TC | | 17 | 29 | | 5 | |
| FSB0154NB | 17*29*7 TC | | 17 | 29 | | 7 | |
| FSB0083NB | 17*29*7/13 HSCYL | | 17 | 29 | | 7 | 13 |
| FSB0661NB | 17*29*8 TC | | 17 | 29 | | 8 | |
| FSB0355NB | 18*29*6 TC | | 18 | 29 | | 6 | |
| FSB0392NB | 18*29*7 TC | | 18 | 29 | | 7 | |
| FSB1017NB | 19*29*5 TC | | 19 | 29 | | 5 | |
| FSB0650NB | 19*29*7 TC | | 19 | 29 | | 7 | |
| FSB0091NB | 20*29*4 SB | | 20 | 29 | | 4 | |
| FSB1018NB | 20*29*7 TC | | 20 | 29 | | 7 | |
| FSB1024FB | 21*29*7 TC(VITON)70 Shore | | 21 | 29 | | 7 | |
| FSB1019NB | 22*29*4 TC | | 22 | 29 | | 4 | |
| FSB0617N0 | 22*29*4 VC | | 22 | 29 | | 4 | |
| FSB0583NB | 22*29*5 SB | | 22 | 29 | | 5 | |
| FSB0514NB | 15*29.5*4 TB Green | | 15 | 29.5 | | 4 | |
| FSB0376NB | 15*29.6*4 TB | SR400 (BIG) | 15 | 29.6 | | 4 | |
| FSB0975NB | 23.43*29.77*3.96/6.76 SCY BROWN | NBR80 | 23.43 | 29.77 | | 3.96 | 6.76 |
| FSB1096NB | 9*30*7 TC | | 9 | 30 | | 7 | |
| FSB0325NB | 10*30*7 SC | | 10 | 30 | | 7 | |
| FSB1040NB | 10*30*8 TC | | 10 | 30 | | 8 | |
| FSB0660NB | 10*30*10 TC | | 10 | 30 | | 10 | |
| FSB0993NB | 11*30*7 TC | | 11 | 30 | | 7 | |
| FSB0659NB | 12*30*5 SC | | 12 | 30 | | 5 | |
| FSB0985NB | 12*30*6 TC | | 12 | 30 | | 6 | |
| FSB0643NB | 12*30*7 SC | | 12 | 30 | | 7 | |
| FSB0347NB | 12*30*7 TC | | 12 | 30 | | 7 | |
| FSB0292NB | 12*30*9 TC | | 12 | 30 | | 9 | |
| FSB0390NB | 12*30*10 TC | | 12 | 30 | | 10 | |

| WLK CODE | OIL SEALS | DESCRIPTION | ID | OD1 | OD2 | H1 | H2 |
|-----------|----------------------------|---------------|------|-----|-----|-----|-----|
| FSB0350NB | 13*30*7 TC | | 13 | 30 | | 7 | |
| FSB1087NB | 13*30*8 TC | | 13 | 30 | | 8 | |
| FSC0100NB | 14*30*6 SC | | 14 | 30 | | 6 | |
| FSB0291QS | 14*30*6 SC (VMQ)S304 SPR | SUS304 SPRING | 14 | 30 | | 6 | |
| FSB0291NB | 14*30*6 SC(S304 SPRING) | | 14 | 30 | | 6 | |
| FSB0268NB | 14*30*7 SC | 113LG40 | 14 | 30 | | 7 | |
| FSB1066NB | 14*30*7 TC | | 14 | 30 | | 7 | |
| FSB0620NB | 14*30*8 TC | | 14 | 30 | | 8 | |
| FSB0667NB | 14*30*10 TB | | 14 | 30 | | 10 | |
| FSB0683NB | 14*30*10 TC | | 14 | 30 | | 10 | |
| FSB0290NB | 14*30*13 TC9 | | 14 | 30 | | 13 | |
| FSC0711NB | 14.7*30*7.5/8.5 TCA Brown | 內徑束0.3MM任弘專用 | 14.7 | 30 | | 7.5 | 8.5 |
| FSB0530NB | 14.8*30*5 TC | | 14.8 | 30 | | 5 | |
| FSB0606NB | 14.8*30*5 VC | | 14.8 | 30 | | 5 | |
| FSB0618NB | 15*30*4.5 SC | 534 | 15 | 30 | | 4.5 | |
| FSB1039N0 | 15*30*4.5 VC | | 15 | 30 | | 4.5 | |
| FSB0305NB | 15*30*5 SC | | 15 | 30 | | 5 | |
| FSB0305NS | 15*30*5 SC(S304 SPRING) | | 15 | 30 | | 5 | |
| FSB0304NB | 15*30*5 TC | SE01-15305 | 15 | 30 | | 5 | |
| FSB0304NS | 15*30*5 TC(S304 SPRING) | | 15 | 30 | | 5 | |
| FSB1004NB | 15*30*5.5/5.9 TBV(Blue) | 34-595 | 15 | 30 | | 5.5 | 5.9 |
| FSB1026NB | 15*30*6 TC | | 15 | 30 | | 6 | |
| FSB1081NB | 15*30*7 SC | | 15 | 30 | | 7 | |
| FSB0289NB | 15*30*7 TB | 90311-15307 | 15 | 30 | | 7 | |
| FSB0289FB | 15*30*7 TB(VITON) | | 15 | 30 | | 7 | |
| FSB0288NB | 15*30*7 TC | K75 STARTING | 15 | 30 | | 7 | |
| FSB0288QS | 15*30*7 TC (VMQ)S304 SPR | S304 SPRING | 15 | 30 | | 7 | |
| FSB0288NS | 15*30*7 TC S304 SPRING | | 15 | 30 | | 7 | |
| FSB0288FB | 15*30*7 TC(VITON) | | 15 | 30 | | 7 | |
| FSB0601AB | 15*30*7 TCA(ACM) | | 15 | 30 | | 7 | |
| FSB0685NB | 15*30*7/7.5 TCV(NBR80) | | 15 | 30 | | 7 | 7.5 |
| FSB0613NB | 15*30*7.5/8.5 TCA(Y) Brown | 14658-43G00 | 15 | 30 | | 7.5 | 8.5 |
| FSB1065FS | 15*30*8 SC(VITON)S304SPR | 白鐵彈簧 | 15 | 30 | | 8 | |
| FSB0395NB | 15*30*8 TB | | 15 | 30 | | 8 | |
| FSB0297NB | 15*30*8 TC4 | | 15 | 30 | | 8 | |
| FSB0681FB | 15*30*10 SC(FKM)VITON | | 15 | 30 | | 10 | |
| FSB0388NB | 15*30*10 TC | | 15 | 30 | | 10 | |
| FSB0388FB | 15*30*10 TC (FKM)VITON | | 15 | 30 | | 10 | |
| FSB0287NB | 16*30*4.5 SC | | 16 | 30 | | 4.5 | |
| FSB0999NB | 16*30*4.5 TG | | 16 | 30 | | 4.5 | |
| FSC0556NB | 16*30*5 TC | 不排產取S304 | 16 | 30 | | 5 | |
| FSC0556NS | 16*30*5 TC(S304 SPRING) | | 16 | 30 | | 5 | |
| FSB1073NB | 16*30*6 TC | | 16 | 30 | | 6 | |
| FSB0377N0 | 16*30*7 KC | BR2219E | 16 | 30 | | 7 | |
| FSB1038NB | 16*30*7 SB | | 16 | 30 | | 7 | |
| FSB0286NB | 16*30*7 SC | 0107-18-216A | 16 | 30 | | 7 | |
| FSB0286FB | 16*30*7 SC (FKM)VITON | | 16 | 30 | | 7 | |
| FSB0375NB | 16*30*7 TB | 60S (SMALL) | 16 | 30 | | 7 | |
| FSB0353NB | 16*30*7 TC | 90311-16001 | 16 | 30 | | 7 | |
| FSB0263N0 | 16*30*8 KC | | 16 | 30 | | 8 | |
| FSB0263F0 | 16*30*8 KC (FKM)VITON | | 16 | 30 | | 8 | |
| FSB0284NB | 16*30*8 SC | TR/TS/GP | 16 | 30 | | 8 | |
| FSB0285NB | 16*30*8 TB | | 16 | 30 | | 8 | |
| FSB0283NB | 16*30*8 TC | 9285-016002 | 16 | 30 | | 8 | |
| FSB0282NB | 16*30*10 TC3 | | 16 | 30 | | 10 | |
| FSC0889FB | 16.4*30*5 TF(VITON) | | 16.4 | 30 | | 5 | |
| FSB0500NB | 17*30*5 SC | | 17 | 30 | | 5 | |

| WLK CODE | OIL SEALS | DESCRIPTION | ID | OD1 | OD2 | H1 | H2 |
|-----------|------------------------------|--------------------------|-------|-----|-----|------|-----|
| FSB0500FB | 17*30*5 SC (FKM)VITON | | 17 | 30 | | 5 | |
| FSB0367NB | 17*30*5 TC | D350-1508-40 | 17 | 30 | | 5 | |
| FSB0021NB | 17*30*6 SC | EM500, 48089-H5000 | 17 | 30 | | 6 | |
| FSB0021NS | 17*30*6 SC(S304SPRING) | | 17 | 30 | | 6 | |
| FSB1001NB | 17*30*6 TB | | 17 | 30 | | 6 | |
| FSB0281NB | 17*30*6 TC | 60955 SV50 | 17 | 30 | | 6 | |
| FSB1060NB | 17*30*7 DC | | 17 | 30 | | 7 | |
| FSB1060FB | 17*30*7 DC(VITON75) | Brown(VITON75度) | 17 | 30 | | 7 | |
| FSB0280NB | 17*30*7 SC | | 17 | 30 | | 7 | |
| FSB0280FB | 17*30*7 SC(VITON) | | 17 | 30 | | 7 | |
| FSB0280QB | 17*30*7 SC(VMQ) | | 17 | 30 | | 7 | |
| FSB0672NB | 17*30*7 TB | | 17 | 30 | | 7 | |
| FSB0279NB | 17*30*7 TC | 48029-H5000 | 17 | 30 | | 7 | |
| FSB0279FB | 17*30*7 TC (FKM)VITON | | 17 | 30 | | 7 | |
| FSB0279QB | 17*30*7 TC (VMQ) | | 17 | 30 | | 7 | |
| FSB1134NB | 17*30*7/7.5 TCV(NBR80) BROWN | | 17 | 30 | | 7 | 7.5 |
| FSB0278NB | 17*30*8 TC | 48125-01E00 | 17 | 30 | | 8 | |
| FSB0363NB | 17*30/37*8 Y(TCA5) | AZ0744E | 17 | 30 | 37 | 8 | |
| FSB0299NB | 17*30/40*9 TC6Y(TC35Y) | | 17 | 30 | 40 | 9 | |
| FSB0641NB | 17*30*10 TC | | 17 | 30 | | 10 | |
| FSB0396NB | 17.4*30*7 TC | 90311-17062 | 17.4 | 30 | | 7 | |
| FSB0310NB | 18*30*5 HTCR | | 18 | 30 | | 5 | |
| FSB0309NB | 18*30*5 TC | 90029-21005, 90311-18001 | 18 | 30 | | 5 | |
| FSB0107NB | 18*30*6 SC | | 18 | 30 | | 6 | |
| FSB0356NB | 18*30*6 TC | | 18 | 30 | | 6 | |
| FSB1125NB | 18*30*6/6.5 TCY | | 18 | 30 | | 6 | 6.5 |
| FSB0311NB | 18*30*6.4/8.1 TCY Green | 020 301 227C | 18 | 30 | | 6.4 | 8.1 |
| FSB1059NB | 18*30*7 DC NBR80 Brown | | 18 | 30 | | 7 | |
| FSB0312NB | 18*30*7 HTMW(HTBW) | 9640 003 1980 | 18 | 30 | | 7 | |
| FSB0277NB | 18*30*7 TB(TZ)Green | NBR60度STIHL | 18 | 30 | | 7 | |
| FSB0298NB | 18*30*7 TC | 48029-92G00, 90311-18001 | 18 | 30 | | 7 | |
| FSB0298FB | 18*30*7 TC(VITON) | | 18 | 30 | | 7 | |
| FSB0313NB | 18*30*7.5 TB(TM) | | 18 | 30 | | 7.5 | |
| FSB0635NB | 18*30*8 SM | 90311-18010 | 18 | 30 | | 8 | |
| FSB0602NB | 18*30*8 TB | | 18 | 30 | | 8 | |
| FSB0314NB | 18*30*8 TC | 90311-18001 | 18 | 30 | | 8 | |
| FSB0314FB | 18*30*8 TC(VITON) | | 18 | 30 | | 8 | |
| FSB0634NB | 18*30*8 TZ | | 18 | 30 | | 8 | |
| FSB0981NB | 18*30*10 TC | | 18 | 30 | | 10 | |
| FSB0398NB | 18*30*10/15 DC4Y | | 18 | 30 | | 10 | 15 |
| FSB0276NB | 18.9*30*5 SC | 91202-035-000 | 18.9 | 30 | | 5 | |
| FSB0599NB | 19*30*5 TC | | 19 | 30 | | 5 | |
| FSB0640NB | 19*30*6/6.5 TCV(NBR85) | | 19 | 30 | | 6 | 6.5 |
| FSB0275NB | 19*30*7 TC | 456150800 | 19 | 30 | | 7 | |
| FSB0275FB | 19*30*7 TC(VITON) | | 19 | 30 | | 7 | |
| FSB1046NB | 19*30*8 TC | | 19 | 30 | | 8 | |
| FSB0067NB | 19.05*30*8.33 TCY | 0.750*1.181*0.328 TCY | 19.05 | 30 | | 8.33 | |
| FSB9956NB | 19.5*30*6/6.5 TCV | | 19.5 | 30 | | 6 | 6.5 |
| FSC0890FB | 19.8*30*5 TF(VITON) | | 19.8 | 30 | | 5 | |
| FSB1072NB | 20*30*4 SC | | 20 | 30 | | 4 | |
| FSB0296NB | 20*30*4.5 HTCW | RD250LC | 20 | 30 | | 4.5 | |
| FSB0272NB | 20*30*4.5 SC | | 20 | 30 | | 4.5 | |
| FSB1000NB | 20*30*4.5 TG | | 20 | 30 | | 4.5 | |
| FSB1083NB | 20*30*5 KC | | 20 | 30 | | 5 | |
| FSB0301NB | 20*30*5 SC | 93104-19082 | 20 | 30 | | 5 | |
| FSB0068NB | 20*30*5 TC | | 20 | 30 | | 5 | |
| FSB0639NB | 20*30*5/5.5 TCV(NBR85) | | 20 | 30 | | 5 | 5.5 |

| WLK CODE | OIL SEALS | DESCRIPTION | ID | OD1 | OD2 | H1 | H2 |
|-----------|------------------------------|-----------------------|-------|-------|-------|-------|-----|
| FSB0680NB | 20*30*5/6 TCVJ(TEFLON) Brown | | 20 | 30 | | 5 | 6 |
| FSB0372NB | 20*30/34*5/6.1 SC5 Green | 478-1508-40 | 20 | 30 | 34 | 5 | 6.1 |
| FSB0295NB | 20*30*6 SC | 93101-20138 | 20 | 30 | | 6 | |
| FSB0300NB | 20*30*6 TC | 90311-20306, RZ250 | 20 | 30 | | 6 | |
| FSB0270NB | 20*30*6 TZ(TB) | | 20 | 30 | | 6 | |
| FSB0317NB | 20*30*7 SB(SZ) Green | 707-1508-OS | 20 | 30 | | 7 | |
| FSB0316NB | 20*30*7 SC | EY14 (ROBIN) MD095355 | 20 | 30 | | 7 | |
| FSB0316FB | 20*30*7 SC(VITON) | | 20 | 30 | | 7 | |
| FSB0303NB | 20*30*7 TB(TM)Green | EY14 (ROBIN) | 20 | 30 | | 7 | |
| FSB0269NB | 20*30*7 TC | ROBIN MD-009535 | 20 | 30 | | 7 | |
| FSB0269QB | 20*30*7 TC (VMQ) | | 20 | 30 | | 7 | |
| FSB0269FB | 20*30*7 TC(VITON) | | 20 | 30 | | 7 | |
| FSB0580NB | 20*30*8 DB Green | 5000231050 | 20 | 30 | | 8 | |
| FSB0293NB | 20*30*8 TC | | 20 | 30 | | 8 | |
| FSB0318NB | 20*30*10 TC | | 20 | 30 | | 10 | |
| FSC0908NB | 21*30*6.5 TC | | 21 | 30 | | 6.5 | |
| FSB0319NB | 22*30*4 SC | | 22 | 30 | | 4 | |
| FSB1127NB | 22*30*4 TC | | 22 | 30 | | 4 | |
| FSB0170N0 | 22*30*5 V軟 | | 22 | 30 | | 5 | |
| FSB0321NB | 22*30*6 TC | | 22 | 30 | | 6 | |
| FSB0322NB | 22*30*7 SC | | 22 | 30 | | 7 | |
| FSB0393NB | 22*30*7 TC | | 22 | 30 | | 7 | |
| FSB0668NB | 23*30*4/6 SCY | | 23 | 30 | | 4 | 6 |
| FSB0323NB | 23*30*5 TC | | 23 | 30 | | 5 | |
| FSB0991NB | 25*30*7 VC | | 25 | 30 | | 7 | |
| FSC9911NB | 19.05*30.16*6.35 SC | | 19.05 | 30.16 | | 6.35 | |
| FSC0948NB | 17.48*30.18*7.95 TCV(NBR) | NBR80 | 17.48 | 30.18 | | 7.95 | |
| FSC0816NB | 19.05*30.18*3.18 SC | | 19.05 | 30.18 | | 3.18 | |
| FSC0080NB | 19*30.45*3 SB | | 19 | 30.45 | | 3 | |
| FSC0779NB | 15*31*7 TC | | 15 | 31 | | 7 | |
| FSC0900NB | 16*31*7 TC | | 16 | 31 | | 7 | |
| FSC0079NB | 17*31*7 TC | 48029-04100 | 17 | 31 | | 7 | |
| FSC0167NB | 18*31*7 TC | | 18 | 31 | | 7 | |
| FSC0669NB | 19*31*6 TC | | 19 | 31 | | 6 | |
| FSC0174NB | 19*31*7 SB | | 19 | 31 | | 7 | |
| FSC0678NB | 20*31*7 SC | | 20 | 31 | | 7 | |
| FSC0352NB | 20*31*7 SZ | MB-0020307 | 20 | 31 | | 7 | |
| FSC0429NB | 20*31*7 TB(TZ) | | 20 | 31 | | 7 | |
| FSC0194NB | 20*31*7 TC | D350150840 | 20 | 31 | | 7 | |
| FSC0502NB | 20*31*7.3 TGB | DT193171 | 20 | 31 | | 7.3 | |
| FSC0077NB | 21*31*7 TC | | 21 | 31 | | 7 | |
| FSC0077FB | 21*31*7 TC(FKM)VITON | | 21 | 31 | | 7 | |
| FSC0785NB | 22*31*5 TC | | 22 | 31 | | 5 | |
| FSC0841NB | 22*31*6.5 TC3 | | 22 | 31 | | 6.5 | |
| FSC0724NB | 25*31*7 TC | | 25 | 31 | | 7 | |
| FSC0219N0 | 26*31*3 VB | | 26 | 31 | | 3 | |
| FSC0412NB | 22.73*31.12*4.45 VB(BH5) | 0.895*1.255*0.175 VB | 22.73 | 31.12 | | 4.45 | |
| FSC9959N0 | 23.83*31.34/41.28*16.66Y | MD-339118(NBR80) | 23.83 | 31.34 | 41.28 | 16.66 | |
| FSC0175NB | 19*31.5*8 TB | | 19 | 31.5 | | 8 | |
| FSC9966NB | 12.7*31.75*6.35 TC | | 12.7 | 31.75 | | 6.35 | |
| FSC9967FB | 15.88*31.75*6.35 SB(FKM) | VITON | 15.88 | 31.75 | | 6.35 | |
| FSC9985NB | 15.88*31.75*6.35 SC | 0.625*1.25*0.25 SC | 15.88 | 31.75 | | 6.35 | |
| FSC9989NB | 15.88*31.75*6.35 TB | | 15.88 | 31.75 | | 6.35 | |
| FSC9988NB | 15.88*31.75*6.35 TC | | 15.88 | 31.75 | | 6.35 | |
| FSC9913NB | 15.88*31.75*7.95 SC | | 15.88 | 31.75 | | 7.95 | |
| FSC9923NB | 17.48*31.75*6.35 TC | | 17.48 | 31.75 | | 6.35 | |
| FSC0171NB | 18.42*31.75*4.9 SBP | 0.725*1.250*0.193 SBP | 18.42 | 31.75 | | 4.9 | |

| WLK CODE | OIL SEALS | DESCRIPTION | ID | OD1 | OD2 | H1 | H2 |
|------------|-----------------------------|--------------------------|-------|-------|------|-------|------|
| FSC9915NB | 19.05*31.75*4.78 SB | | 19.05 | 31.75 | | 4.78 | |
| FSC0185NB | 19.05*31.75*6.35 SB | 0.750*1.250*0.250 SB | 19.05 | 31.75 | | 6.35 | |
| FSC0090NB | 19.05*31.75*6.35 SBY Copper | 0.750*1.250*0.250 SBY | 19.05 | 31.75 | | 6.35 | |
| FSC9965NB | 19.05*31.75*6.35 TB | | 19.05 | 31.75 | | 6.35 | |
| FSC0186NB | 19.05*31.75*6.35 TC | 0.750*1.250*0.250 TC | 19.05 | 31.75 | | 6.35 | |
| FSC0186FB | 19.05*31.75*6.35 TC(FKM) | VITON | 19.05 | 31.75 | | 6.35 | |
| FSC9979N0 | 19.05*31.75*6.35 VB | 0.750*1.250*0.250 VB | 19.05 | 31.75 | | 6.35 | |
| FSC0461NB | 19.05*31.75*7.95 HSC Blue1 | 0.75*1.25*0.313 HSC | 19.05 | 31.75 | | 7.95 | |
| FSC0466NB | 19.05*31.75*7.95 SC | 0.750*1.250*0.313 SC | 19.05 | 31.75 | | 7.95 | |
| FSC0105NB | 19.05*31.75*8 TB | 0.750*1.250*0.313 TB | 19.05 | 31.75 | | 8 | |
| FSC9917NB | 20.65*31.75*4.76 SB | | 20.65 | 31.75 | | 4.76 | |
| FSC99957NB | 22.22*31.75*4.76 SC | | 22.22 | 31.75 | | 4.76 | |
| FSC9957FB | 22.22*31.75*4.76 SC(VITO) | VITON | 22.22 | 31.75 | | 4.76 | |
| FSC9902NB | 22.22*31.75*4.96 SC | | 22.22 | 31.75 | | 4.96 | |
| FSC9999NB | 22.23*31.75*4.78 VZ | 8960060 | 22.23 | 31.75 | | 4.78 | |
| FSC9964NB | 22.23*31.75*6.35 TC | | 22.23 | 31.75 | | 6.35 | |
| FSC0501N0 | 25.4*31.75*3.175 VB(VM) | 1.000*1.250*0.125 VB(VM) | 25.4 | 31.75 | | 3.175 | |
| FSC9961NB | 25.4*31.75*6.4 TC | 1.000*1.250*0.250 TC | 25.4 | 31.75 | | 6.4 | |
| FSC0210NB | 20.65*31.8*4.97 SBP | 0.813*1.252*0.196 SBP | 20.65 | 31.8 | | 4.97 | |
| FSC0473N0 | 22.35*31.8*4.83 VB | | 22.35 | 31.8 | | 4.83 | |
| FSC0192N0 | 22.35*31.9*4.83 VB(VZ) | 0.880*1.256*0.190 VB(VZ) | 22.35 | 31.9 | | 4.83 | |
| FSC0191N0 | 22.23*31.95*4.8 VB(VM) | 0.875*1.258*0.189 VB | 22.23 | 31.95 | | 4.8 | |
| FSC0177NB | 10*32*5 SC | | 10 | 32 | | 5 | |
| FSC0775NB | 10*32*7 TC | | 10 | 32 | | 7 | |
| FSC0543NB | 12*32*5 TC | | 12 | 32 | | 5 | |
| FSC0490NB | 12*32*6 SB | | 12 | 32 | | 6 | |
| FSC0120NB | 12*32*7 HTB | 9640 003 1280 | 12 | 32 | | 7 | |
| FSC0076NB | 12*32*7 SC | | 12 | 32 | | 7 | |
| FSC0161NB | 12*32*7 TB | | 12 | 32 | | 7 | |
| FSC0075NB | 12*32*7 TC | | 12 | 32 | | 7 | |
| FSC0893NB | 12*32/36.5*12.6/15.3 TGY | N029-082(NBR80) | 12 | 32 | 36.5 | 12.6 | 15.3 |
| FSC0777NB | 13*32*7 SC | | 13 | 32 | | 7 | |
| FSC0768NB | 13*32*8 TC | | 13 | 32 | | 8 | |
| FSC0806NB | 14*32*5 SC | | 14 | 32 | | 5 | |
| FSC0498NB | 14*32*7 TC | | 14 | 32 | | 7 | |
| FSC0099N0 | 14*32*7.5 KC3 | | 14 | 32 | | 7.5 | |
| FSC0074NB | 14*32*7.5 KCCY | | 14 | 32 | | 7.5 | |
| FSB0397NB | 14*32*8 TC | | 14 | 32 | | 8 | |
| FSC0710NB | 14.5*32*7.5 TCA(Y) Brown | ID- extra 0.3MM | 14.5 | 32 | | 7.5 | |
| FSC0387NB | 14.8*32*7.5 TCA(Y) Brown | 894156-5890 | 14.8 | 32 | | 7.5 | |
| FSC0387AB | 14.8*32*7.5 Y(ACM) | BROWN (ACM) | 14.8 | 32 | | 7.5 | |
| FSC0377NB | 15*32*5 TC | | 15 | 32 | | 5 | |
| FSC0138NB | 15*32*7 SC | | 15 | 32 | | 7 | |
| FSC0073NB | 15*32*7 TC | 90311-15327 | 15 | 32 | | 7 | |
| FSC0103NB | 15*32*7 TC (SPECIAL) | 特材806 | 15 | 32 | | 7 | |
| FSC0073FB | 15*32*7 TC(VITON) | | 15 | 32 | | 7 | |
| FSC0143N0 | 15*32*7 VB | | 15 | 32 | | 7 | |
| FSC0531NB | 15*32*7.5 SPTC | 14.8*32*7.5 | 15 | 32 | | 7.5 | |
| FSC0544NB | 15*32*8 TC | | 15 | 32 | | 8 | |
| FSC0544FB | 15*32*8 TC(VITON) | | 15 | 32 | | 8 | |
| FSC0544QB | 15*32*8 TC(VMQ) | 9437 | 15 | 32 | | 8 | |
| FSC0072NB | 15*32*9 TC | | 15 | 32 | | 9 | |
| FSC0124NB | 16*32*7 TC | | 16 | 32 | | 7 | |
| FSC0124NSS | 16*32*7 TC (SUS)+INSERT | SUS304鐵殼+彈簧 | 16 | 32 | | 7 | |
| FSC0124FS1 | 16*32*7 TC(FKM)S304SPRIN | VITON+S304 SPRING | 16 | 32 | | 7 | |
| FSC0124FS | 16*32*7 TC(S304SPRING) | | 16 | 32 | | 7 | |

| WLK CODE | OIL SEALS | DESCRIPTION | ID | OD1 | OD2 | H1 | H2 |
|-----------|-----------------------------|--------------------------|------|-----|-----|------|-----|
| FSC0939NB | 16*32*10 SC | | 16 | 32 | | 10 | |
| FSC0681NB | 16*32*10 TC | | 16 | 32 | | 10 | |
| FSC0894NB | 17*32*5 SC | | 17 | 32 | | 5 | |
| FSC0859NB | 17*32*5 TC | | 17 | 32 | | 5 | |
| FSC0154NB | 17*32*6 SC | 91234GK1004 | 17 | 32 | | 6 | |
| FSC0457NB | 17*32*6 TC | | 17 | 32 | | 6 | |
| FSC0954NB | 17*32*7 DC | | 17 | 32 | | 7 | |
| FSC0555NB | 17*32*7 TB | | 17 | 32 | | 7 | |
| FSC0071NB | 17*32*7 TC | AE0750E | 17 | 32 | | 7 | |
| FSC0071FB | 17*32*7 TC(VITON) | | 17 | 32 | | 7 | |
| FSC0567NB | 17*32*8 DC BROWN | AW0751E | 17 | 32 | | 8 | |
| FSC0545NB | 17*32*8 TC | AE0751G | 17 | 32 | | 8 | |
| FSC0815NB | 17*32*10 SC | | 17 | 32 | | 10 | |
| FSC0521NB | 17.5*32*7 TC | 48029-W0501 | 17.5 | 32 | | 7 | |
| FSC0733NB | 17.5*32*8 TZ | BP2175E;NBR90 | 17.5 | 32 | | 8 | |
| FSC0763NB | 18*32*6 TC | | 18 | 32 | | 6 | |
| FSC0763FB | 18*32*6 TC(VITON) | | 18 | 32 | | 6 | |
| FSC0554NB | 18*32*7 TB | | 18 | 32 | | 7 | |
| FSC0128NB | 18*32*7 TC | 90311-18032/21 | 18 | 32 | | 7 | |
| FSC0168PB | 18*32*7 TCJ (PTFE) | | 18 | 32 | | 7 | |
| FSC0949NB | 18*32*7.9 TZ | BP2175E,WLK | 18 | 32 | | 7.9 | |
| FSC0772NB | 18*32*8 DC | | 18 | 32 | | 8 | |
| FSC0566NB | 18*32*8 TC | | 18 | 32 | | 8 | |
| FSC0713NB | 18*32*8 TZ(TB) | | 18 | 32 | | 8 | |
| FSC0759NB | 18*32*10 TC | | 18 | 32 | | 10 | |
| FSC0179NB | 18*32*10/15 DCY | SHOCK SEAL NISSAN | 18 | 32 | | 10 | 15 |
| FSC0550NB | 18*32/38*13.5 TC5Y | NISSAN B12 GEAR FORK | 18 | 32 | 38 | 13.5 | |
| FSC0176NB | 19*32*5 HTCR | | 19 | 32 | | 5 | |
| FSC0111NB | 19*32*5 TC | | 19 | 32 | | 5 | |
| FSC0178FS | 19*32*7 SC(FKM+S304 SPRING) | | 19 | 32 | | 7 | |
| FSC0532NB | 19*32*7 TB | | 19 | 32 | | 7 | |
| FSC0070NB | 19*32*7 TC | 90311-19003 | 19 | 32 | | 7 | |
| FSC0070FB | 19*32*7 TC (FKM)VITON | | 19 | 32 | | 7 | |
| FSC0070NS | 19*32*7 TC(S304 SPRING) | | 19 | 32 | | 7 | |
| FSC0844NB | 19*32*7/7.5 TCV | | 19 | 32 | | 7 | 7.5 |
| FSC0533NB | 19*32*8 SB | | 19 | 32 | | 8 | |
| FSC0355NB | 19*32*8 TC | 90311-19001, 48125-S5001 | 19 | 32 | | 8 | |
| FSC0355FB | 19*32*8 TC(VITON) | | 19 | 32 | | 8 | |
| FSC0907N0 | 20*32*4 VC | | 20 | 32 | | 4 | |
| FSC0358NB | 20*32*5 HTCR | 90029-21020/21007 | 20 | 32 | | 5 | |
| FSC0358AB | 20*32*5 HTCR(ACM) | | 20 | 32 | | 5 | |
| FSC0087FB | 20*32*5 SC (FKM)VITON | | 20 | 32 | | 5 | |
| FSC0112NB | 20*32*5 TC | | 20 | 32 | | 5 | |
| FSC0112FB | 20*32*5 TC (FKM)VITON | | 20 | 32 | | 5 | |
| FSC0112NS | 20*32*5 TC(S304 SPRING) | | 20 | 32 | | 5 | |
| FSC0845NB | 20*32*5/5.5 TCV | | 20 | 32 | | 5 | 5.5 |
| FSC0414NB | 20*32*6 HTCL | | 20 | 32 | | 6 | |
| FSC0195NB | 20*32*6 TC | | 20 | 32 | | 6 | |
| FSC0936FB | 20*32*6/6.5 TCV(VITON) | | 20 | 32 | | 6 | 6.5 |
| FSC0773NB | 20*32*7 DC | | 20 | 32 | | 7 | |
| FSC0196NB | 20*32*7 SC Blue 1 | | 20 | 32 | | 7 | |
| FSC0129NB | 20*32*7 TC | 15165-64010 | 20 | 32 | | 7 | |
| FSC0129FS | 20*32*7 TC (FKM)S304 | VITON+S304 SPRING | 20 | 32 | | 7 | |
| FSC0129QB | 20*32*7 TC (VMQ) | | 20 | 32 | | 7 | |
| FSC0197NB | 20*32*8 TB | | 20 | 32 | | 8 | |
| FSC0068NB | 20*32*8 TC | | 20 | 32 | | 8 | |
| FSC0891NB | 20*32*10 TC | | 20 | 32 | | 10 | |

| WLK CODE | OIL SEALS | DESCRIPTION | ID | OD1 | OD2 | H1 | H2 |
|-----------|-----------------------|----------------|------|-------|-----|-----|-----|
| FSC0198NB | 20*32*10/15 DCY | 90313-20005 | 20 | 32 | | 10 | 15 |
| FSC0655NB | 21*32*5 TC | | 21 | 32 | | 5 | |
| FSC0712NB | 21*32*7 TC | | 21 | 32 | | 7 | |
| FSC0712FB | 21*32*7 TC(FKM)VITON | | 21 | 32 | | 7 | |
| FSC0784NB | 21*32*8 TC | | 21 | 32 | | 8 | |
| FSC0162N0 | 22*32*4.5 VB | | 22 | 32 | | 4.5 | |
| FSC0222NB | 22*32*5 TB | B/S 3HP | 22 | 32 | | 5 | |
| FSC0223NB | 22*32*5 TC | | 22 | 32 | | 5 | |
| FSC0102NB | 22*32*5.5 SC | | 22 | 32 | | 5.5 | |
| FSC0909NB | 22*32*5.5 TC | | 22 | 32 | | 5.5 | |
| FSC0394NB | 22*32*6 TC(Green) | 478-1508-40 | 22 | 32 | | 6 | |
| FSC0394FB | 22*32*6 TC(VITON) | | 22 | 32 | | 6 | |
| FSC0623NB | 22*32*6.5 SC | | 22 | 32 | | 6.5 | |
| FSC0676QB | 22*32*7 SC(VMQ) | | 22 | 32 | | 7 | |
| FSC0804NB | 22*32*7 TB | | 22 | 32 | | 7 | |
| FSC0126NB | 22*32*7 TC | AE1116E | 22 | 32 | | 7 | |
| FSC0126FB | 22*32*7 TC (FKM)VITON | | 22 | 32 | | 7 | |
| FSC0126QB | 22*32*7 TC(VMQ) | | 22 | 32 | | 7 | |
| FSC0923NB | 22*32*8 TB | | 22 | 32 | | 8 | |
| FSC0842NB | 22*32*10 SC | | 22 | 32 | | 10 | |
| FSC0899NB | 22.5*32*5 SC | | 22.5 | 32 | | 5 | |
| FSC0619NB | 23*32*7 TC | | 23 | 32 | | 7 | |
| FSC0738N0 | 23*32*8/9 KCY | | 23 | 32 | | 8 | 9 |
| FSC0616NB | 24*32*4 SC | | 24 | 32 | | 4 | |
| FSC0190NB | 24*32*4 TC | | 24 | 32 | | 4 | |
| FSC0190FB | 24*32*4 TC(FKM)VITON | | 24 | 32 | | 4 | |
| FSC0739NB | 24*32*5 SB | | 24 | 32 | | 5 | |
| FSC0528NB | 24*32*7 KC | | 24 | 32 | | 7 | |
| FSC0902NB | 24*32*7 SC | | 24 | 32 | | 7 | |
| FSC0721NB | 24*32*7 TC | | 24 | 32 | | 7 | |
| FSC0671NB | 25*32*4 KB | | 25 | 32 | | 4 | |
| FSC0512NB | 25*32*4 SC | | 25 | 32 | | 4 | |
| FSC0512FB | 25*32*4 SC(VITON) | | 25 | 32 | | 4 | |
| FSC0720NB | 25*32*4 TC | | 25 | 32 | | 4 | |
| FSC0720FB | 25*32*4 TC(VITON) | | 25 | 32 | | 4 | |
| FSC0618N0 | 25*32*4 VC | | 25 | 32 | | 4 | |
| FSC0838NB | 25*32*5 TC | | 25 | 32 | | 5 | |
| FSC0736N0 | 25*32*5 VB | | 25 | 32 | | 5 | |
| FSC0455NB | 25*32*6 TC | | 25 | 32 | | 6 | |
| FSC0455FB | 25*32*6 TC(VITON) | | 25 | 32 | | 6 | |
| FSC0407NB | 25*32*7 TC | | 25 | 32 | | 7 | |
| FSC0407FB | 25*32*7 TC(VITON) | | 25 | 32 | | 7 | |
| FSC0131N0 | 30*32*4 VB | | 30 | 32 | | 4 | |
| FSC0464NB | 15*32.15*7 TC | | 15 | 32.15 | | 7 | |
| FSC0564NB | 20*32.5*7/7.6 TC4 | AE8027E(NBR90) | 20 | 32.5 | | 7 | 7.6 |
| FSC0840NB | 17*32.9*3.6 TB | K1705,N029-075 | 17 | 32.9 | | 3.6 | |
| FSC0654NB | 15*33*7 SC | | 15 | 33 | | 7 | |
| FSC0472NB | 15*33*7 TC | | 15 | 33 | | 7 | |
| FSC0754NB | 17*33*7 TB | | 17 | 33 | | 7 | |
| FSC0360NB | 17*33*7 TC | | 17 | 33 | | 7 | |
| FSC0808NB | 17*33*8 SC | | 17 | 33 | | 8 | |
| FSC0704NB | 17*33*8 TC | | 17 | 33 | | 8 | |
| FSC0650NB | 18*33*6 HTCL Brown | BH4243E | 18 | 33 | | 6 | |
| FSC0101NB | 18.5*33*9.5 SC | | 18.5 | 33 | | 9.5 | |
| FSC0679NB | 19*33*7 TC | | 19 | 33 | | 7 | |
| FSC0749NB | 19*33*8 TC | | 19 | 33 | | 8 | |
| FSC0621NB | 19*33*8/9 TCY | | 19 | 33 | | 8 | 9 |

| WLK CODE | OIL SEALS | DESCRIPTION | ID | OD1 | OD2 | H1 | H2 |
|-----------|-------------------------------------|--------------------------|-------|--------|-----|------|------|
| FSC0613FB | 20*33*7 SC(VITON)FKM | | 20 | 33 | | 7 | |
| FSC0629NB | 20*33*7 TC | | 20 | 33 | | 7 | |
| FSC0751NB | 20*33*8 SC | | 20 | 33 | | 8 | |
| FSC0896NB | 20*33*9 SC | | 20 | 33 | | 9 | |
| FSC0614NB | 20*33*10 SB | | 20 | 33 | | 10 | |
| FSC0750NB | 20*33*10 TC | | 20 | 33 | | 10 | |
| FSC0212NB | 21*33*8/9.5 TCY | 011-997-67-46 | 21 | 33 | | 8 | 9.5 |
| FSC0431NB | 22*33*6 TC | | 22 | 33 | | 6 | |
| FSC0165N0 | 22*33*6.2 VC | | 22 | 33 | | 6.2 | |
| FSC0519NB | 22*33*6.5 TC | | 22 | 33 | | 6.5 | |
| FSC0881NB | 22*33*7 TC | | 22 | 33 | | 7 | |
| FSC0831NB | 22*33*10/15 DCY | | 22 | 33 | | 10 | 15 |
| FSC0559NB | 24*33*5 SB | | 24 | 33 | | 5 | |
| FSC0067NB | 24*33*10.5 TB4 | | 24 | 33 | | 10.5 | |
| FSC0499NB | 25*33*4 TC | | 25 | 33 | | 4 | |
| FSC0499FB | 25*33*4 TC (FKM75 Shore) | | 25 | 33 | | 4 | |
| FSC0562VB | 25*33*4 TCJ(PTFE+FKM75 Shore | V2(FKM75度+PTFE20%) | 25 | 33 | | 4 | |
| FSC0829N0 | 25*33*4 VB | | 25 | 33 | | 4 | |
| FSC0637NB | 25*33*4 VG | | 25 | 33 | | 4 | |
| FSC0692NB | 25*33*5 TB | | 25 | 33 | | 5 | |
| FSC0905NB | 25*33*6 SC | | 25 | 33 | | 6 | |
| FSC0615NB | 25*33*6 TC | | 25 | 33 | | 6 | |
| FSC0240NB | 25*33*7 SC | | 25 | 33 | | 7 | |
| FSC0819NB | 27*33*4 SC | | 27 | 33 | | 4 | |
| FSC0820N0 | 27*33*4 VB | | 27 | 33 | | 4 | |
| FSB0565NB | 19.05*33.325*7.93 TB Green Painting | 0.750*1.312*0.312 TB | 19.05 | 33.325 | | 7.93 | |
| FSC9914NB | 19.05*33.33*6.35 SC | | 19.05 | 33.33 | | 6.35 | |
| FSC0493NB | 19.05*33.33*7.93 SC | | 19.05 | 33.33 | | 7.93 | |
| FSC0093NB | 19.05*33.33*7.93/8.93 TZ | 0.75*1.311*0.312/0.352TZ | 19.05 | 33.33 | | 7.93 | 8.93 |
| FSC0187NB | 19.05*33.33*7.93/9.4 TC | 0.75*1.312*0.312/0.37 TC | 19.05 | 33.33 | | 7.93 | 9.4 |
| FSC9991NB | 19.05*33.33*7.95 TC | | 19.05 | 33.33 | | 7.95 | |
| FSC9905NB | 19.05*33.35*6.35 SB | | 19.05 | 33.35 | | 6.35 | |
| FSC9928NB | 19.05*33.35*6.35 TC | | 19.05 | 33.35 | | 6.35 | |
| FSC9954NB | 19.05*33.35*7.95 TB | | 19.05 | 33.35 | | 7.95 | |
| FSC9996NB | 19.05*33.35*7.95 TC | 0.750*1.313*0.313 TC | 19.05 | 33.35 | | 7.95 | |
| FSC9977NB | 19.5*33.35*10 TC | | 19.5 | 33.35 | | 10 | |
| FSC9972NB | 22.23*33.35*6.35 SC | | 22.23 | 33.35 | | 6.35 | |
| FSC9970N0 | 25.4*33.35*3.96 VB | | 25.4 | 33.35 | | 3.96 | |
| FSC0503NB | 21*33.7*9 TC4 | | 21 | 33.7 | | 9 | |
| FSC0484NB | 8*34*8 TC | 91203-292-005 | 8 | 34 | | 8 | |
| FSC0776NB | 12*34*7 TC | | 12 | 34 | | 7 | |
| FSC0780NB | 16*34*7 TC | | 16 | 34 | | 7 | |
| FSC0843NB | 17*34*4 SB | | 17 | 34 | | 4 | |
| FSC0794NB | 17*34*4 TB | | 17 | 34 | | 4 | |
| FSC0509NB | 17*34*4 TC | | 17 | 34 | | 4 | |
| FSC0155NB | 17*34*7 SC | | 17 | 34 | | 7 | |
| FSC0066NB | 17*34*7 TC | | 17 | 34 | | 7 | |
| FSC0836NB | 17*34*8 TB | | 17 | 34 | | 8 | |
| FSC0709NB | 18*34*7 TB | | 18 | 34 | | 7 | |
| FSC0617NB | 18*34*7 TC | | 18 | 34 | | 7 | |
| FSC0882NB | 18*34*8 TB | | 18 | 34 | | 8 | |
| FSC0172NB | 18.5*34*6.5 TC (Green) | | 18.5 | 34 | | 6.5 | |
| FSC0391NB | 19*34*6 TC | | 19 | 34 | | 6 | |
| FSC0680NB | 19*34*7 TC | | 19 | 34 | | 7 | |
| FSC0912NB | 20*34*4 SC | | 20 | 34 | | 4 | |
| FSC0796NB | 20*34*6 TC | | 20 | 34 | | 6 | |
| FSC0065NB | 20*34*7 SC | | 20 | 34 | | 7 | |

| WLK CODE | OIL SEALS | DESCRIPTION | ID | OD1 | OD2 | H1 | H2 |
|-----------|---------------------------|-----------------------|-------|-------|-------|------|-----|
| FSC0200NB | 20*34*7 TC | | 20 | 34 | | 7 | |
| FSC0642NB | 20*34*7/8 HTC4L(NBR90) | 90311-20008 | 20 | 34 | | 7 | 8 |
| FSC0201NB | 20*34*10/15 DC4Y | 90316-20006 | 20 | 34 | | 10 | 15 |
| FSC0416NB | 22*34*5 HTCR | | 22 | 34 | | 5 | |
| FSC0224NB | 22*34*5 TC | | 22 | 34 | | 5 | |
| FSC0451NB | 22*34*6 HTCL | | 22 | 34 | | 6 | |
| FSC0225NB | 22*34*6 HTCR | 90311-22346 | 22 | 34 | | 6 | |
| FSC0425NB | 22*34*6 TC | | 22 | 34 | | 6 | |
| FSC0458NB | 22*34*6 TCA(Y)BROWN | (BZ5179E) | 22 | 34 | | 6 | |
| FSC0718NB | 22*34*6.5 HTCR | 90029-21022 | 22 | 34 | | 6.5 | |
| FSC0743NB | 22*34*6.5 TC | | 22 | 34 | | 6.5 | |
| FSC0458AB | 22*34*6.5 TCA(ACM) | | 22 | 34 | | 6.5 | |
| FSC0064NB | 22*34*7 SC | | 22 | 34 | | 7 | |
| FSC0226NB | 22*34*7 TC | 90311-22347 | 22 | 34 | | 7 | |
| FSC0227NB | 22*34*10/15 DCY | 90316-22003 | 22 | 34 | | 10 | 15 |
| FSC0770NB | 23*34*6 TC | | 23 | 34 | | 6 | |
| FSC0884NB | 23*34*7 TC | | 23 | 34 | | 7 | |
| FSC0497NB | 23*34*8 HTCL | | 23 | 34 | | 8 | |
| FSC0479NB | 24*34*7 TC | | 24 | 34 | | 7 | |
| FSC0246NB | 24.6*34*7 TB | EC10 使用 | 24.6 | 34 | | 7 | |
| FSC0848NB | 25*34*5 TC | | 25 | 34 | | 5 | |
| FSC0547NB | 25*34*7 TC | | 25 | 34 | | 7 | |
| FSC0674NB | 25*34*7 TM | N029-061 | 25 | 34 | | 7 | |
| FSC0933NB | 26*34*4.6/8 TCY | | 26 | 34 | | 4.6 | 8 |
| FSC0789NB | 27*34*3 VB | | 27 | 34 | | 3 | |
| FSC0221N0 | 27*34*3.5 KC | | 27 | 34 | | 3.5 | |
| FSC0821NB | 27*34*4 SC | | 27 | 34 | | 4 | |
| FSC0823N0 | 27*34*4 VB | | 27 | 34 | | 4 | |
| FSC0822N0 | 27*34*4 VC | | 27 | 34 | | 4 | |
| FSC0408N0 | 28*34*5 VCY | AG1524P | 28 | 34 | | 5 | |
| FSC0063NB | 24*34.2*6.5 SC | | 24 | 34.2 | | 6.5 | |
| FSC0456NB | 26*34.5*5.5 HTCL | 91214-GK1-004 | 26 | 34.5 | | 5.5 | |
| FSC9896NB | 19.05*34.52*6.35/7.1 TC4 | NBR80 | 19.05 | 34.52 | | 6.35 | 7.1 |
| FSC0062NB | 14.99*34.8*6.35 SC | 0.590*1.370*0.250 SC | 14.99 | 34.8 | | 6.35 | |
| FSC0520NB | 19.05*34.9*9.5 TC | | 19.05 | 34.9 | | 9.5 | |
| FSC9993NB | 22.5*34.9*3.75 SC | 2972 | 22.5 | 34.9 | | 3.75 | |
| FSC9899NB | 12.7*34.92*6.35 TC | | 12.7 | 34.92 | | 6.35 | |
| FSC9976NB | 15.88*34.92*6.35 TC | 0.625*1.375*0.25 TC | 15.88 | 34.92 | | 6.35 | |
| FSC9912NB | 15.88*34.92*7.95 SC | | 15.88 | 34.92 | | 7.95 | |
| FSC9916NB | 17.48*34.92*6.35 TC | | 17.48 | 34.92 | | 6.35 | |
| FSC9969NB | 19.05*34.92*6.35 TB | | 19.05 | 34.92 | | 6.35 | |
| FSC9933NB | 19.05*34.92*6.35 TC | | 19.05 | 34.92 | | 6.35 | |
| FSC9909NB | 19.05*34.92*7.95 SC | | 19.05 | 34.92 | | 7.95 | |
| FSC9904NB | 19.05*34.92*7.95 TB | | 19.05 | 34.92 | | 7.95 | |
| FSC9953NB | 19.05*34.92*9.53 TC | | 19.05 | 34.92 | | 9.53 | |
| FSC0236NB | 22.2*34.92*6.35 SC | 0.874*1.375*0.250 SC | 22.2 | 34.92 | | 6.35 | |
| FSC9927NB | 22.23*34.92*6.35 TB | | 22.23 | 34.92 | | 6.35 | |
| FSC9959NB | 25.4*34.92*6.35 TC | | 25.4 | 34.92 | | 6.35 | |
| FSC9958N0 | 25.81*34.92/42.47*16.2 Y3 | MD-162076/198128 | 25.81 | 34.92 | 42.47 | 16.2 | |
| FSC9908NB | 28.58*34.92*3.96 VB | | 28.58 | 34.92 | | 3.96 | |
| FSC9987NB | 19.05*34.93*6.35 TC | | 19.05 | 34.93 | | 6.35 | |
| FSC9992NB | 19.05*34.93*9.53 TC | | 19.05 | 34.93 | | 9.53 | |
| FSC0061NB | 19.84*34.93*6.35 SC | 0.781*1.375*0.250 SC | 19.84 | 34.93 | | 6.35 | |
| FSC0211NB | 20.65*34.93*6.35 SC | 0.813*1.375*0.250 SC | 20.65 | 34.93 | | 6.35 | |
| FSC0209NB | 20.65*34.93*6.35 TC | 0.813*1.375*0.250 TC | 20.65 | 34.93 | | 6.35 | |
| FSC0430NB | 21.82*34.93*6.22 SC | 0.859*1.375*0.245 SC | 21.82 | 34.93 | | 6.22 | |
| FSC0238NB | 22.23*34.93*6.35 SBP | 0.875*1.375*0.250 SBP | 22.23 | 34.93 | | 6.35 | |

| WLK CODE | OIL SEALS | DESCRIPTION | ID | OD1 | OD2 | H1 | H2 |
|-----------|---------------------------------|--------------------------|-------|-------|-----|------|------|
| FSC9958NB | 22.23*34.93*6.35 SC | | 22.23 | 34.93 | | 6.35 | |
| FSC0237NB | 22.23*34.93*6.35 TB | 0.875*1.375*0.250 TB | 22.23 | 34.93 | | 6.35 | |
| FSC9980NB | 22.23*34.93*6.35 TC | | 22.23 | 34.93 | | 6.35 | |
| FSC0239NB | 22.23*34.93*8 SB(SZ) | 0.875*1.375*0.315 SB(SZ) | 22.23 | 34.93 | | 8 | |
| FSC9968NB | 22.23*34.93*8 SB Green Painting | | 22.23 | 34.93 | | 8 | |
| FSC0244NB | 24.64*34.93*6.65 SBP | 0.970*1.375*0.262 SBP | 24.64 | 34.93 | | 6.65 | |
| FSC0626NB | 10*35*7 TC | | 10 | 35 | | 7 | |
| FSC0374NB | 12*35*7 TC | | 12 | 35 | | 7 | |
| FSC0809NB | 12*35*10 SC | | 12 | 35 | | 10 | |
| FSC0855NB | 13*35*10 SC | | 13 | 35 | | 10 | |
| FSC0622NB | 14*35*7 SC | | 14 | 35 | | 7 | |
| FSC0557NB | 14*35*7 TC | | 14 | 35 | | 7 | |
| FSC0557FB | 14*35*7 TC(VITON) | | 14 | 35 | | 7 | |
| FSC0872NB | 14*35*8 TC | | 14 | 35 | | 8 | |
| FSC0078NB | 14*35*10 SC | | 14 | 35 | | 10 | |
| FSC0060NB | 14*35*11/14.5 TC6Y(TC65) | | 14 | 35 | | 11 | 14.5 |
| FSC0950NB | 14.8*35*7.5/9 TCA | | 14.8 | 35 | | 7.5 | 9 |
| FSC0130N0 | 15*35*4 VC | | 15 | 35 | | 4 | |
| FSC0696NB | 15*35*6 TC | | 15 | 35 | | 6 | |
| FSC0144FB | 15*35*7 SC(VITON) | | 15 | 35 | | 7 | |
| FSC0145NB | 15*35*7 TB(TM) | 商標WLK STIHL | 15 | 35 | | 7 | |
| FSC0059NB | 15*35*7 TC | | 15 | 35 | | 7 | |
| FSC0059FB | 15*35*7 TC (FKM)VITON | | 15 | 35 | | 7 | |
| FSC0609NB | 15*35*7.5 TC | | 15 | 35 | | 7.5 | |
| FSC0903NB | 15*35*7.5 TCA | | 15 | 35 | | 7.5 | |
| FSC0147NB | 15*35*8 SC | | 15 | 35 | | 8 | |
| FSC0116NB | 15*35*9 TCCY | | 15 | 35 | | 9 | |
| FSC0148NB | 15*35*9.5/18 DCY | | 15 | 35 | | 9.5 | 18 |
| FSC0149NB | 15*35*10 SC | | 15 | 35 | | 10 | |
| FSC0150NB | 15*35*10 TC | | 15 | 35 | | 10 | |
| FSC0368NB | 15*35*10 Y | | 15 | 35 | | 10 | |
| FSC0892NB | 15*35/39*14/16 TGY | N029-081(NBR80) | 15 | 35 | 39 | 14 | 16 |
| FSC0424NB | 16*35*7 TC | | 16 | 35 | | 7 | |
| FSC0897NB | 16*35*8 SC | | 16 | 35 | | 8 | |
| FSC0682NB | 16*35*10 SC | | 16 | 35 | | 10 | |
| FSC0508NB | 16*35*10 TC | | 16 | 35 | | 10 | |
| FSC0758NB | 17*35*5 TC | | 17 | 35 | | 5 | |
| FSC0058NB | 17*35*6 TC | | 17 | 35 | | 6 | |
| FSC0665N0 | 17*35*6/7.5 KCY | | 17 | 35 | | 6 | 7.5 |
| FSC0605NB | 17*35*7 DC(Green) | P-262 | 17 | 35 | | 7 | |
| FSC0156NB | 17*35*7 SC | | 17 | 35 | | 7 | |
| FSC0057NB | 17*35*7 TC | 8067-17030 | 17 | 35 | | 7 | |
| FSC0487NB | 17*35*7/7.5 TCV Green | | 17 | 35 | | 7 | 7.5 |
| FSC0488NB | 17*35*8 SB Green | | 17 | 35 | | 8 | |
| FSC0056NB | 17*35*8 TC | | 17 | 35 | | 8 | |
| FSC0494NB | 17*35*8.5 TC5 | | 17 | 35 | | 8.5 | |
| FSC0055NB | 17*35*9 TCCY | | 17 | 35 | | 9 | |
| FSC0495NB | 17*35*10 TC | | 17 | 35 | | 10 | |
| FSC0495QB | 17*35*10 TC (VMQ) | | 17 | 35 | | 10 | |
| FSC0096N0 | 17*35*12 KCY | | 17 | 35 | | 12 | |
| FSC0054NB | 17*35*12 TC6(TCU) | | 17 | 35 | | 12 | |
| FSC0869NB | 18*35*5 SC | | 18 | 35 | | 5 | |
| FSB0387NB | 18*35*7 TC | | 18 | 35 | | 7 | |
| FSC0053NB | 18*35*8 TC | | 18 | 35 | | 8 | |
| FSC0053FB | 18*35*8 TC(VITON) | | 18 | 35 | | 8 | |
| FSC0169NB | 18*35*10 SC | | 18 | 35 | | 10 | |
| FSC0388NB | 18*35*10 TC | | 18 | 35 | | 10 | |

| WLK CODE | OIL SEALS | DESCRIPTION | ID | OD1 | OD2 | H1 | H2 |
|------------|---------------------------|--------------------|------|-----|-----|------|-----|
| FSC0435NB | 18.7*35*7 TC | 18.7*35*7/7.7 TC4Y | 18.7 | 35 | | 7 | |
| FSC0856NB | 19*35*5 TC | | 19 | 35 | | 5 | |
| FSC0022NB | 19*35*7 TC | MB-166582 | 19 | 35 | | 7 | |
| FSC0022NSS | 19*35*7 TC (S304+INSERT) | | 19 | 35 | | 7 | |
| FSC0022FS | 19*35*7 TC(FKM)S304 | VITON | 19 | 35 | | 7 | |
| FSC0022NS | 19*35*7 TC(S304 SPRING) | | 19 | 35 | | 7 | |
| FSC0865NB | 19*35*8 TB | | 19 | 35 | | 8 | |
| FSC0052NB | 19*35*8 TC | | 19 | 35 | | 8 | |
| FSC0052FB | 19*35*8 TC (FKM)VITON | | 19 | 35 | | 8 | |
| FSC0697NB | 19*35*10 TC | | 19 | 35 | | 10 | |
| FSC0122NB | 20*35*4 TC (SPECIAL) | 特材905料 | 20 | 35 | | 4 | |
| FSC0051NB | 20*35*4.5 SC | NT65/70 起動 | 20 | 35 | | 4.5 | |
| FSC0876NB | 20*35*5 SC | | 20 | 35 | | 5 | |
| FSC0935NB | 20*35*5 TC | | 20 | 35 | | 5 | |
| FSC0935FB | 20*35*5 TC(VITON) | | 20 | 35 | | 5 | |
| FSC0611NB | 20*35*5.5 HTCR | 09283-20040 | 20 | 35 | | 5.5 | |
| FSC0611QB | 20*35*5.5 HTCR(VMQ) | | 20 | 35 | | 5.5 | |
| FSC0050NB | 20*35*5.5 SC | 24151-73B01 | 20 | 35 | | 5.5 | |
| FSC0393NB | 20*35*6 TC | | 20 | 35 | | 6 | |
| FSC0049NB | 20*35*7 DC | | 20 | 35 | | 7 | |
| FSC0468NB | 20*35*7 SC(BLUE) | | 20 | 35 | | 7 | |
| FSC0468FB | 20*35*7 SC(VITON) | | 20 | 35 | | 7 | |
| FSC0468QB | 20*35*7 SC(VMQ) | | 20 | 35 | | 7 | |
| FSC0426NB | 20*35*7 SG | | 20 | 35 | | 7 | |
| FSC0465NB | 20*35*7 TB Green Painting | | 20 | 35 | | 7 | |
| FSC00455NB | 20*35*7 TB(TM) | | 20 | 35 | | 7 | |
| FSC0048NB | 20*35*7 TC | KF34, 09283-20024 | 20 | 35 | | 7 | |
| FSC0048FS | 20*35*7 TC (FKM)S304 | VITON+S304 SPRING | 20 | 35 | | 7 | |
| FSC0048NS | 20*35*7 TC (S304 SPRING) | | 20 | 35 | | 7 | |
| FSC0048QB | 20*35*7 TC (VMQ) | | 20 | 35 | | 7 | |
| FSC0048FB | 20*35*7 TC VITON | | 20 | 35 | | 7 | |
| FSC0202PB | 20*35*7 TCJ (PTFE) | | 20 | 35 | | 7 | |
| FSC0663NB | 20*35*7/7.5 TCV(Green) | | 20 | 35 | | 7 | 7.5 |
| FSC0441NO | 20*35*8 KC | (FS102) | 20 | 35 | | 8 | |
| FSC0517NB | 20*35*8 SB | | 20 | 35 | | 8 | |
| FSC0113NB | 20*35*8 SC | 90043-10026 | 20 | 35 | | 8 | |
| FSC0901NB | 20*35*8 TB | | 20 | 35 | | 8 | |
| FSC0047NB | 20*35*8 TC | 32113-01B00 | 20 | 35 | | 8 | |
| FSC0818NB | 20*35*10 DC | | 20 | 35 | | 10 | |
| FSC0104NB | 20*35*10 TC | | 20 | 35 | | 10 | |
| FSC0104QB | 20*35*10 TC (VMQ) | | 20 | 35 | | 10 | |
| FSC0104FB | 20*35*10 TC(VITON) | | 20 | 35 | | 10 | |
| FSC0046NB | 21*35*6 SC | | 21 | 35 | | 6 | |
| FSC0214NB | 21*35*6 TC | | 21 | 35 | | 6 | |
| FSC0688NB | 21*35*7 SC | | 21 | 35 | | 7 | |
| FSC0045NB | 21*35*7 TC | | 21 | 35 | | 7 | |
| FSC0092NB | 21*35*12.5 Leather | | 21 | 35 | | 12.5 | |
| FSC0799AB | 21.6*35*7 HTGR(ACM) | 11363 | 21.6 | 35 | | 7 | |
| FSC0091NB | 22*35*5 TC | | 22 | 35 | | 5 | |
| FSC0119NO | 22*35*5 VC | | 22 | 35 | | 5 | |
| FSC0910NB | 22*35*5.5 TC | | 22 | 35 | | 5.5 | |
| FSC0228NB | 22*35*6 SC | | 22 | 35 | | 6 | |
| FSC0229NB | 22*35*6 TA | | 22 | 35 | | 6 | |
| FSC0139NB | 22*35*6 TC | GX120 | 22 | 35 | | 6 | |
| FSC0139FB | 22*35*6 TC(VITON) | | 22 | 35 | | 6 | |
| FSC0440NO | 22*35*6.5 KC | (FS101) | 22 | 35 | | 6.5 | |
| FSC0230NB | 22*35*7 DC | | 22 | 35 | | 7 | |

| WLK CODE | OIL SEALS | DESCRIPTION | ID | OD1 | OD2 | H1 | H2 |
|------------|--------------------------|------------------------|------|-----|-----|-----|-----|
| FSC0043NB | 22*35*7 SC | KND3/5B起動, EY13, KF53 | 22 | 35 | | 7 | |
| FSC0044NB | 22*35*7 TB | | 22 | 35 | | 7 | |
| FSC0042NB | 22*35*7 TC | 90311-21020 | 22 | 35 | | 7 | |
| FSC0042NS | 22*35*7 TC(S304 SPRING) | | 22 | 35 | | 7 | |
| FSC0042NSS | 22*35*7 TC(SUS)+INSERT | | 22 | 35 | | 7 | |
| FSC0042FB | 22*35*7 TC(VITON) | | 22 | 35 | | 7 | |
| FSC0042QB | 22*35*7 TC(VMQ) | | 22 | 35 | | 7 | |
| FSC0849NB | 22*35*7/7.5 TCV | | 22 | 35 | | 7 | 7.5 |
| FSC0610NB | 22*35*7.5 TA2 | | 22 | 35 | | 7.5 | |
| FSC0041NB | 22*35*8 TB | 90311-22103 | 22 | 35 | | 8 | |
| FSC0534NB | 22*35*8 TBK W/Felt | AD1127J | 22 | 35 | | 8 | |
| FSC0040NB | 22*35*8 TC | K75 油封 | 22 | 35 | | 8 | |
| FSC0460NB | 22*35*10 TB | | 22 | 35 | | 10 | |
| FSC0462NB | 22*35*10 TC | | 22 | 35 | | 10 | |
| FSC0474NS | 23*35*6 SC (S304 SPRING) | F25-2301-0 | 23 | 35 | | 6 | |
| FSC0039NB | 23*35*7 TC | | 23 | 35 | | 7 | |
| FSC0952NB | 23*35/41*12/16 TC45Y | BR1157E,WLK(NBR80) | 23 | 35 | 41 | 12 | 16 |
| FSC0653NB | 24*35*5.5 SC(NBR85) | | 24 | 35 | | 5.5 | |
| FSC0038NB | 24*35*6 HSCR | | 24 | 35 | | 6 | |
| FSC0095FB | 24*35*6 HSGW(FKM)VITON | | 24 | 35 | | 6 | |
| FSC0037NB | 24*35*6 SC | 90043-10027 | 24 | 35 | | 6 | |
| FSC0877NB | 24*35*6 TC | | 24 | 35 | | 6 | |
| FSC0241NB | 24*35*7 SC | | 24 | 35 | | 7 | |
| FSC0241FB | 24*35*7 SC(VITON) | TC修掉副唇 | 24 | 35 | | 7 | |
| FSC0133NB | 24*35*7 TC | | 24 | 35 | | 7 | |
| FSC0133FB | 24*35*7 TC(VITON) | | 24 | 35 | | 7 | |
| FSC0036NB | 24.6*35*7 TC | | 24.6 | 35 | | 7 | |
| FSC0638NB | 25*35*4 TC | | 25 | 35 | | 4 | |
| FSC0675NB | 25*35*4 VG | | 25 | 35 | | 4 | |
| FSC0035NB | 25*35*5 SC | TS50/105/60/70/70C起動 | 25 | 35 | | 5 | |
| FSC0034NB | 25*35*5 TC | | 25 | 35 | | 5 | |
| FSC0034FB | 25*35*5 TC(VITON) | | 25 | 35 | | 5 | |
| FSC0115N0 | 25*35*5 VB(VZ) | 90312-25015 | 25 | 35 | | 5 | |
| FSC0218N0 | 25*35*5 VC | | 25 | 35 | | 5 | |
| FSC0946NB | 25*35*5.5 TC | | 25 | 35 | | 5.5 | |
| FSC0702NB | 25*35*6 HSCR | | 25 | 35 | | 6 | |
| FSC0249NB | 25*35*6 HSCR | MD-069950;MD-041012 | 25 | 35 | | 6 | |
| FSC0248NB | 25*35*6 SC | 90043-10035 | 25 | 35 | | 6 | |
| FSC0033NB | 25*35*6 TC | MD-069950,93102-25270 | 25 | 35 | | 6 | |
| FSC0033FB | 25*35*6 TC(FKM)VITON | VITON | 25 | 35 | | 6 | |
| FSC0797NB | 25*35/40*6.5/7.6 SCY | | 25 | 35 | 40 | 6.5 | 7.6 |
| FSC0252NB | 25*35*7 DC | | 25 | 35 | | 7 | |
| FSC0032NB | 25*35*7 SC | 113LG47 | 25 | 35 | | 7 | |
| FSC0032FB | 25*35*7 SC(VITON) | | 25 | 35 | | 7 | |
| FSC0251NB | 25*35*7 TB(TM) | 43252-G3200 | 25 | 35 | | 7 | |
| FSC0031NB | 25*35*7 TC | KND70A/105;RK7起動, KF64 | 25 | 35 | | 7 | |
| FSC0031QB | 25*35*7 TC (VMQ) | | 25 | 35 | | 7 | |
| FSC0031NS | 25*35*7 TC(S304 SPRING) | | 25 | 35 | | 7 | |
| FSC0031FB | 25*35*7 TC(VITON) | | 25 | 35 | | 7 | |
| FSC0250NB | 25*35*7/9 TBY | | 25 | 35 | | 7 | 9 |
| FSC0399NB | 25*35*8 TC | | 25 | 35 | | 8 | |
| FSC0795NB | 25*35*9 TC | | 25 | 35 | | 9 | |
| FSC0400NB | 25*35*10 TC | | 25 | 35 | | 10 | |
| FSC0030NB | 26*35*5 SC | NT75 起動 | 26 | 35 | | 5 | |
| FSC0729NB | 26*35*7 SC | | 26 | 35 | | 7 | |
| FSC0716NB | 26*35*7 TC | | 26 | 35 | | 7 | |

| WLK CODE | OIL SEALS | DESCRIPTION | ID | OD1 | OD2 | H1 | H2 |
|-----------|---------------------------|----------------------|------|-------|------|-----|------|
| FSC0824NB | 27*35*4 SC | | 27 | 35 | | 4 | |
| FSC0826N0 | 27*35*4 VB | | 27 | 35 | | 4 | |
| FSC0825N0 | 27*35*4 VC | | 27 | 35 | | 4 | |
| FSC0656NB | 27*35*7 SC | | 27 | 35 | | 7 | |
| FSC0357NB | 28*35*4 TC | | 28 | 35 | | 4 | |
| FSC0471NB | 28*35*4 TG | | 28 | 35 | | 4 | |
| FSC0728NB | 28*35*4 VB | | 28 | 35 | | 4 | |
| FSC0757NB | 28*35*4 VG | | 28 | 35 | | 4 | |
| FSC0608NB | 28*35*5 TC | | 28 | 35 | | 5 | |
| FSC0272NB | 28*35*6 TC | | 28 | 35 | | 6 | |
| FSC0450NB | 28*35*7 TC | | 28 | 35 | | 7 | |
| FSC0708NB | 28*35*9 TC | | 28 | 35 | | 9 | |
| FSC0363N0 | 30*35*3 VB | | 30 | 35 | | 3 | |
| FSC0413NB | 25.4*35.05*4.70 VB(BH4) | 1.000*1.380*0.185 VB | 25.4 | 35.05 | | 4.7 | |
| FSC0500N0 | 27*35.2/37.7*4/11.5 KC6Y | K2048 | 27 | 35.2 | 37.7 | 4 | 11.5 |
| FSC0117NB | 12*36*7 TC | | 12 | 36 | | 7 | |
| FSC0778NB | 14*36*7 TC | | 14 | 36 | | 7 | |
| FSC0664NB | 15*36*7 SC | | 15 | 36 | | 7 | |
| FSC0378NB | 15*36*7 TC | | 15 | 36 | | 7 | |
| FSC0383NB | 16*36*7 TC | | 16 | 36 | | 7 | |
| FSC0385NB | 17*36*7 TC | | 17 | 36 | | 7 | |
| FSC0839NB | 18*36*7 TC | | 18 | 36 | | 7 | |
| FSC0432NB | 19*36*7 TC | | 19 | 36 | | 7 | |
| FSC0857NB | 19*36*8 SC | | 19 | 36 | | 8 | |
| FSC0649NB | 20*36*5 TC | | 20 | 36 | | 5 | |
| FSC0727NB | 20*36*7 HTCL | | 20 | 36 | | 7 | |
| FSC0029NB | 20*36*7 SC | | 20 | 36 | | 7 | |
| FSC0204NB | 20*36*7 TC | | 20 | 36 | | 7 | |
| FSC0774NB | 20*36*10 DC | | 20 | 36 | | 10 | |
| FSC0620NB | 20*36*10 TC | | 20 | 36 | | 10 | |
| FSC0469NB | 20*36*10/15 DCY | | 20 | 36 | | 10 | 15 |
| FSC0647NB | 22*36*5 HTCL Brown | | 22 | 36 | | 5 | |
| FSC0677NB | 22*36*5 HTCR | | 22 | 36 | | 5 | |
| FSC0232NB | 22*36*6 TC | | 22 | 36 | | 6 | |
| FSC0089NB | 22*36*7 SC | | 22 | 36 | | 7 | |
| FSC0359NB | 22*36*7 TC | | 22 | 36 | | 7 | |
| FSC0233NB | 22*36*7/10 DCY | | 22 | 36 | | 7 | 10 |
| FSC0234NB | 22*36*7.5/11 DCY | | 22 | 36 | | 7.5 | 11 |
| FSC0800NB | 22*36*8 TC | | 22 | 36 | | 8 | |
| FSC0028NB | 22*36*10 DC | 09283-22610 | 22 | 36 | | 10 | |
| FSC0235NB | 22*36*10/15 DCY | 90316-22001/8 | 22 | 36 | | 10 | 15 |
| FSC0476NB | 23*36*7 TC | | 23 | 36 | | 7 | |
| FSC0433NB | 23*36/37*7.5/9.5 KCY | NBR Gray Black | 23 | 36 | 37 | 7.5 | 9.5 |
| FSC0433Q0 | 23*36/37*7.5/9.5 KCY(VMQ) | (VMQ) Black | 23 | 36 | 37 | 7.5 | 9.5 |
| FSC0651NB | 24*36*5.4/6.8 TCY NBR90 | BP5504E | 24 | 36 | | 5.4 | 6.8 |
| FSC0516NB | 24*36*6 TB | AD8851F | 24 | 36 | | 6 | |
| FSC0242NB | 24*36*6 TC | | 24 | 36 | | 6 | |
| FSC0397NB | 24*36*7 TC | | 24 | 36 | | 7 | |
| FSC0397FB | 24*36*7 TC(VITON) | | 24 | 36 | | 7 | |
| FSC0833NB | 24*36*8 TC | | 24 | 36 | | 8 | |
| FSC0254NB | 25*36*5 SC | | 25 | 36 | | 5 | |
| FSC0887NB | 25*36*7 SB | | 25 | 36 | | 7 | |
| FSC0448NB | 25*36*7 TC | | 25 | 36 | | 7 | |
| FSC0255NB | 25*36*8 TC | | 25 | 36 | | 8 | |
| FSC0788NB | 26*36*5 TC | | 26 | 36 | | 5 | |
| FSC0853NB | 26*36*6 TC | | 26 | 36 | | 6 | |
| FSC0684NB | 26*36*7 TC | | 26 | 36 | | 7 | |

| WLK CODE | OIL SEALS | DESCRIPTION | ID | OD1 | OD2 | H1 | H2 |
|-----------|-----------------------------|----------------------|------|-------|-----|------|----|
| FSC0266NB | 26*36*10.5 TB4 | 109-23145-00 | 26 | 36 | | 10.5 | |
| FSC0267NB | 26*36*10.5 TC4 | | 26 | 36 | | 10.5 | |
| FSC0027NB | 27*36*6 TC | | 27 | 36 | | 6 | |
| FSC0755NB | 28*36*4 TZ | | 28 | 36 | | 4 | |
| FSC0452NB | 28*36*5 SB | | 28 | 36 | | 5 | |
| FSC0919NB | 28*36*5 TC | | 28 | 36 | | 5 | |
| FSC0273NB | 28*36*7 TC | | 28 | 36 | | 7 | |
| FSC0834NB | 28*36*8 TZ | | 28 | 36 | | 8 | |
| FSC0744N0 | 29*36*8 VB | | 29 | 36 | | 8 | |
| FSC0811NB | 30*36*5 SC | | 30 | 36 | | 5 | |
| FSC0811FB | 30*36*5 SC(VITON) | | 30 | 36 | | 5 | |
| FSB1130NB | 24*36.5*6.5/9 KC4Y(NBR90 | | 24 | 36.5 | | 6.5 | 9 |
| FSC9984NB | 25*36.5*6 Y2(軟) | 12342-PR3-000 | 25 | 36.5 | | 6 | |
| FSC0263NB | 25.4*36.5*7.92 TB | 1.000*1.437*0.312 TB | 25.4 | 36.5 | | 7.92 | |
| FSC0510N0 | 27*36.5*5.5 KM3 | | 27 | 36.5 | | 5.5 | |
| FSC9994NB | 25.4*36.51*6.4 SC | 1.000*1.437*0.250 SC | 25.4 | 36.51 | | 6.4 | |
| FSC9898NB | 25.4*36.53*6.35 TB | | 25.4 | 36.53 | | 6.35 | |
| FSC9974NB | 25.4*36.53*6.35 TC | 1.000*1.438*0.250 TC | 25.4 | 36.53 | | 6.35 | |
| FSC0934NB | 12*37*7 TC | | 12 | 37 | | 7 | |
| FSC0380NB | 15*37*7 TC | | 15 | 37 | | 7 | |
| FSC0386NB | 17*37*7 TC | | 17 | 37 | | 7 | |
| FSC0026NB | 18*37*5 SC | | 18 | 37 | | 5 | |
| FSC0025NB | 18*37*7 TC | | 18 | 37 | | 7 | |
| FSC0024NB | 18*37*8 TC | | 18 | 37 | | 8 | |
| FSC0753NB | 19*37*6.5/9 Y | | 19 | 37 | | 6.5 | 9 |
| FSC0181NB | 19*37*7 TC | | 19 | 37 | | 7 | |
| FSC0906NB | 19*37*10 SC | | 19 | 37 | | 10 | |
| FSC0932NB | 20*37*4/6 GA | | 20 | 37 | | 4 | 6 |
| FSC0108NB | 20*37*7 TC | | 20 | 37 | | 7 | |
| FSC0108FB | 20*37*7 TC (FKM)VITON | | 20 | 37 | | 7 | |
| FSC0023NB | 20*37*8 TC | 09283-20034 | 20 | 37 | | 8 | |
| FSC0846NB | 20*37*10 TC | | 20 | 37 | | 10 | |
| FSC0021NB | 21*37*7 TC | | 21 | 37 | | 7 | |
| FSC0635NB | 22*37*6 TC | | 22 | 37 | | 6 | |
| FSC0396NB | 22*37*7 TC | | 22 | 37 | | 7 | |
| FSC0627NB | 22*37*8/9 TCY(NBR90 Shore) | | 22 | 37 | | 8 | 9 |
| FSC0895NB | 23*37*7 SC | | 23 | 37 | | 7 | |
| FSC0925NB | 23*37*7 TC | | 23 | 37 | | 7 | |
| FSC0243NB | 24*37*6 TC | | 24 | 37 | | 6 | |
| FSB0358NB | 24*37*7 TC | | 24 | 37 | | 7 | |
| FSC0850NB | 25*37*5 SC | | 25 | 37 | | 5 | |
| FSC0766NB | 25*37*5 TC | | 25 | 37 | | 5 | |
| FSC0020NB | 25*37*6 SC | 92050013 | 25 | 37 | | 6 | |
| FSC0121NB | 25*37*6 TC Blue | | 25 | 37 | | 6 | |
| FSC0486NB | 25*37*6 TG | | 25 | 37 | | 6 | |
| FSC0722NB | 25*37*7 TB | | 25 | 37 | | 7 | |
| FSC0256NB | 25*37*7 TC | | 25 | 37 | | 7 | |
| FSC0256FB | 25*37*7 TC(VITON) | | 25 | 37 | | 7 | |
| FSC0019NB | 25*37*8 SC | KND70/90 起動 | 25 | 37 | | 8 | |
| FSC0106NB | 25*37*8 TC | 90311-25011 | 25 | 37 | | 8 | |
| FSC0769NB | 25*37*10 TC | | 25 | 37 | | 10 | |
| FSC0257NB | 25*37*10/15 DCY | | 25 | 37 | | 10 | 15 |
| FSC0888NB | 26*37*4/7 GA | | 26 | 37 | | 4 | 7 |
| FSC0913NB | 26*37*6 TC | | 26 | 37 | | 6 | |
| FSC0481NB | 26*37*7 TC | | 26 | 37 | | 7 | |
| FSC0858NB | 26*37*10 TC | | 26 | 37 | | 10 | |
| FSC0421NB | 26*37*10.5 DC4 | | 26 | 37 | | 10.5 | |

| WLK CODE | OIL SEALS | DESCRIPTION | ID | OD1 | OD2 | H1 | H2 |
|-----------|--------------------------|-----------------------|--------|--------|-----|------|-----|
| FSC0657NB | 26*37*10.5 TC4 | | 26 | 37 | | 10.5 | |
| FSC0268NB | 26*37*10.5 TC6 | 36723145060 | 26 | 37 | | 10.5 | |
| FSC0807NB | 27*37*4 TC | | 27 | 37 | | 4 | |
| FSC0018NB | 27*37*5 VC | | 27 | 37 | | 5 | |
| FSC0017NB | 27*37*7 TC | ER100 起動 | 27 | 37 | | 7 | |
| FSC0017QB | 27*37*7 TC(VMQ) | | 27 | 37 | | 7 | |
| FSC0016NB | 27*37*7.5 TC(TC4) | | 27 | 37 | | 7.5 | |
| FSC0015NB | 27*37*9 TC | | 27 | 37 | | 9 | |
| FSC0764NB | 27*37*10.5 DC | | 27 | 37 | | 10.5 | |
| FSC0735NB | 27*37*10.5 TC4 | | 27 | 37 | | 10.5 | |
| FSC0274NB | 28*37*4 J M 軟 | 43215-20541-71Toyota | 28 | 37 | | 4 | |
| FSC0699NB | 28*37*4 TC | | 28 | 37 | | 4 | |
| FSC0803N0 | 28*37*4 VG | | 28 | 37 | | 4 | |
| FSC0756NB | 28*37*5 TC | | 28 | 37 | | 5 | |
| FSC0276NB | 28*37*6 SB(SZ) | 43218-20540-71 Toyota | 28 | 37 | | 6 | |
| FSC0275NB | 28*37*6 TB(TM) | | 28 | 37 | | 6 | |
| FSC0277NB | 28*37*6 TC | | 28 | 37 | | 6 | |
| FSC0628NB | 28*37*7 TC | | 28 | 37 | | 7 | |
| FSC0937NB | 30*37*4 SB | | 30 | 37 | | 4 | |
| FSC0957NB | 30*37*4 SC | | 30 | 37 | | 4 | |
| FSC0367N0 | 30*37*4 VB | | 30 | 37 | | 4 | |
| FSC0715N0 | 30*37*4 VG | | 30 | 37 | | 4 | |
| FSC0527NB | 30*37*5 SB | | 30 | 37 | | 5 | |
| FSC0745NB | 30*37*6.5 SC | | 30 | 37 | | 6.5 | |
| FSC0830NB | 30*37*7 TC | | 30 | 37 | | 7 | |
| FSC0791NB | 31*37*3 VB | | 31 | 37 | | 3 | |
| FSC0568NS | 15*37.25*4.9/5.7 Y(S304) | S304 SPRING | 15 | 37.25 | | 4.9 | 5.7 |
| FSC0110Q0 | 24.3*37.35*9 軟(VMQ) | | 24.3 | 37.35 | | 9 | |
| FSC0660NB | 25.5*37.5*6 HTCR | 90311-25021 | 25.5 | 37.5 | | 6 | |
| FSC9921NB | 28.575*37.947*6.35 TC | 1.125*1.494*0.250 TC | 28.575 | 37.947 | | 6.35 | |
| FSC0742NB | 15*38*7 TC | | 15 | 38 | | 7 | |
| FSC0781NB | 16*38*7 TC | | 16 | 38 | | 7 | |
| FSC0955NB | 16*38*8 TC | | 16 | 38 | | 8 | |
| FSC0553NB | 17*38*7 TC | | 17 | 38 | | 7 | |
| FSC0835NB | 17*38*8 TC | | 17 | 38 | | 8 | |
| FSC0170NB | 18*38*5 SC | 09284-18001 | 18 | 38 | | 5 | |
| FSC0389NB | 18*38*7 TC | | 18 | 38 | | 7 | |
| FSC0606NB | 18*38*8 TC | | 18 | 38 | | 8 | |
| FSC0141NB | 19*38*7 TC | 90311-19008 | 19 | 38 | | 7 | |
| FSC0636NB | 19*38*8 TC | | 19 | 38 | | 8 | |
| FSC0409NB | 20*38*5 TC | | 20 | 38 | | 5 | |
| FSC0285NB | 20*38*7 SC | 93102-20358 | 20 | 38 | | 7 | |
| FSC0285FB | 20*38*7 SC (FKM)VITON | | 20 | 38 | | 7 | |
| FSC0328NB | 20*38*7 TC | 93102-20315 | 20 | 38 | | 7 | |
| FSN0004NB | 20*38*8 TC | | 20 | 38 | | 8 | |
| FSC0810NB | 20*38*10 SC | | 20 | 38 | | 10 | |
| FSC0793NB | 20*38*10 TC | | 20 | 38 | | 10 | |
| FSC0014NB | 20*38*15 DC | | 20 | 38 | | 15 | |
| FSC0107N0 | 21*38*6 VC | | 21 | 38 | | 6 | |
| FSC0868NB | 21*38/48*10 TC5Y | AE1090E 13060-95000 | 21 | 38 | 48 | 10 | |
| FSC0013NB | 21.7*38*8 TC | | 21.7 | 38 | | 8 | |
| FSC0012NB | 22*38*6 SC | | 22 | 38 | | 6 | |
| FSC0695NB | 22*38*6 TC | | 22 | 38 | | 6 | |
| FSC0137NB | 22*38*7 TC | | 22 | 38 | | 7 | |
| FSC0137FB | 22*38*7 TC(VITON) | | 22 | 38 | | 7 | |
| FSC0123NB | 22*38*7/9 TCY | | 22 | 38 | | 7 | 9 |
| FSC0109NB | 22*38*8 TC | | 22 | 38 | | 8 | |

| WLK CODE | OIL SEALS | DESCRIPTION | ID | OD1 | OD2 | H1 | H2 |
|-----------|--------------------------|-----------------------|-------|------|------|------|-----|
| FSC0875NB | 22*38*10 TC | | 22 | 38 | | 10 | |
| FSC0926NB | 23*38*5 SB | | 23 | 38 | | 5 | |
| FSC0646NB | 23*38*6.5/6.8 SCY | | 23 | 38 | | 6.5 | 6.8 |
| FSC0631NB | 23*38*7 SC | | 23 | 38 | | 7 | |
| FSC0477NB | 23*38*7 TC | | 23 | 38 | | 7 | |
| FSC0851NB | 23*38*8 SC | | 23 | 38 | | 8 | |
| FSC0870NB | 24*38*5 TC | | 24 | 38 | | 5 | |
| FSC0866NB | 24*38*7 TB | | 24 | 38 | | 7 | |
| FSC0698NB | 24*38*7 TC | | 24 | 38 | | 7 | |
| FSC0125NB | 24*38*8 TC | AE1252E | 24 | 38 | | 8 | |
| FSC0011NB | 25*38*5 TC | | 25 | 38 | | 5 | |
| FSC0944NB | 25*38*6 HTCR | | 25 | 38 | | 6 | |
| FSC0867NB | 25*38*6 TC | | 25 | 38 | | 6 | |
| FSC0284FB | 25*38*7 SC (FKM)VITON | | 25 | 38 | | 7 | |
| FSC0010NB | 25*38*7 TB(TM) | EY15 SMALL | 25 | 38 | | 7 | |
| FSC0009NB | 25*38*7 TC | EY15/18/20 (ROBIN) | 25 | 38 | | 7 | |
| FSC0009FB | 25*38*7 TC (FKM)VITON | | 25 | 38 | | 7 | |
| FSC0354NB | 25*38*7.5 TC4 | | 25 | 38 | | 7.5 | |
| FSC0630NB | 25*38*8 DC | | 25 | 38 | | 8 | |
| FSC0127NB | 25*38*8 TC | 90311-25110 | 25 | 38 | | 8 | |
| FSC0530NB | 25*38*10 TC | | 25 | 38 | | 10 | |
| FSC0258NB | 25*38*10/15 DCY | 90316-25016, AR1309-P | 25 | 38 | | 10 | 15 |
| FSC0008NB | 26*38*5 TC | 93102-26042 R/DT/DX | 26 | 38 | | 5 | |
| FSC0269NB | 26*38*6.5 SBP | 1.000*1.500*0.255 SBP | 26 | 38 | | 6.5 | |
| FSC0873NB | 26*38*6.5 SCN | 90311-26003 | 26 | 38 | | 6.5 | |
| FSC0007NB | 26*38*7 TC | 09283-26010 | 26 | 38 | | 7 | |
| FSC0625NB | 26*38*8 TC | 09200-26016 | 26 | 38 | | 8 | |
| FSC0006NB | 27*38*6 SC | NM85/55/75/110 起動 | 27 | 38 | | 6 | |
| FSC0561NB | 27*38*7 SC | | 27 | 38 | | 7 | |
| FSC0537NB | 27*38*7 TC | | 27 | 38 | | 7 | |
| FSC0551NB | 28*38*5 SB | | 28 | 38 | | 5 | |
| FSC0004NB | 28*38*5.5 SC | | 28 | 38 | | 5.5 | |
| FSC0003NB | 28*38*6 SC | (P/N6358833) | 28 | 38 | | 6 | |
| FSC0278NB | 28*38*7 SB(SZ) | 90310-28038 | 28 | 38 | | 7 | |
| FSC0140NB | 28*38*7 SC | | 28 | 38 | | 7 | |
| FSC0140FB | 28*38*7 SC(FKM)VITON | | 28 | 38 | | 7 | |
| FSC0641NB | 28*38*7 SM | | 28 | 38 | | 7 | |
| FSC0279NB | 28*38*7 TB | K7 | 28 | 38 | | 7 | |
| FSC0132NB | 28*38*7 TC | 9828-28038 | 28 | 38 | | 7 | |
| FSC0132QB | 28*38*7 TC(VMQ) | | 28 | 38 | | 7 | |
| FSC0437NB | 28*38*7 TZ(TB) | (包腳) | 28 | 38 | | 7 | |
| FSC0943NB | 28*38*8 TC | | 28 | 38 | | 8 | |
| FSC0470NB | 28*38*10/15 DCY | | 28 | 38 | | 10 | 15 |
| FSC0280NB | 28*38*10/15 HTC4YL(TCYL) | 24780-79001 | 28 | 38 | | 10 | 15 |
| FSC0921NB | 28.5*38*6 TC | | 28.5 | 38 | | 6 | |
| FSC0918NB | 29*38*6 SC | | 29 | 38 | | 6 | |
| FSC0341N0 | 29*38*6.4 KC | 495-606 | 29 | 38 | | 6.4 | |
| FSC0863NB | 29*38*7 TC(BROWN) | | 29 | 38 | | 7 | |
| FSC0734NB | 29*38*7/12 Y | | 29 | 38 | | 7 | 12 |
| FSC0686NB | 30*38*4 SC | | 30 | 38 | | 4 | |
| FSC0920NB | 30*38*4 TC | | 30 | 38 | | 4 | |
| FSC0648NB | 30*38*5 SB | | 30 | 38 | | 5 | |
| FSC0417NB | 30*38*5 TC | 90312-30001 | 30 | 38 | | 5 | |
| FSC0459NB | 30*38*6 TC | | 30 | 38 | | 6 | |
| FSC0802NB | 30*38*8 TC | | 30 | 38 | | 8 | |
| FSC0453NB | 30*38/43.5*9/16 Y | NBR80 | 30 | 38 | 43.5 | 9 | 16 |
| FSC9924NB | 19.05*38.1*6.35 SB | | 19.05 | 38.1 | | 6.35 | |

| WLK CODE | OIL SEALS | DESCRIPTION | ID | OD1 | OD2 | H1 | H2 |
|-----------|-------------------------|-------------------------|-------|-------|-----|-------|----|
| FSC9982NB | 19.05*38.1*6.35 TC | 0.750*1.500*0.250 TC | 19.05 | 38.1 | | 6.35 | |
| FSC9929NB | 19.05*38.1*7.95 TC | | 19.05 | 38.1 | | 7.95 | |
| FSC9918NB | 19.05*38.1*9.525 SC | | 19.05 | 38.1 | | 9.525 | |
| FSC9975NB | 22.23*38.1*6.35 TB | | 22.23 | 38.1 | | 6.35 | |
| FSC9973NB | 22.23*38.1*6.35 TC | | 22.23 | 38.1 | | 6.35 | |
| FSC9963NB | 22.23*38.1*6.35/7 TCV | | 22.23 | 38.1 | | 6.35 | 7 |
| FSC9919NB | 22.23*38.1*9.53 TC | | 22.23 | 38.1 | | 9.53 | |
| FSC9906NB | 23.83*38.1*6.35 TC | | 23.83 | 38.1 | | 6.35 | |
| FSC9930NB | 23.83*38.1*9.53 TC | | 23.83 | 38.1 | | 9.53 | |
| FSC0245NB | 24.51*38.1*6.48 TBP | 0.965*1.500*0.255 TBP | 24.51 | 38.1 | | 6.48 | |
| FSC0446NB | 25.4*38.1*6.35 SC | 1.000*1.500*0.250 SC | 25.4 | 38.1 | | 6.35 | |
| FSC9967NB | 25.4*38.1*6.35 TB | | 25.4 | 38.1 | | 6.35 | |
| FSC9978NB | 25.4*38.1*6.35 TC | 1.000*1.500*0.250 TC | 25.4 | 38.1 | | 6.35 | |
| FSC9957NB | 25.4*38.1*7.95 TC | | 25.4 | 38.1 | | 7.95 | |
| FSC0264NB | 25.4*38.1*9.4 TC | 1.000*1.500*0.370 TC | 25.4 | 38.1 | | 9.4 | |
| FSC9931NB | 25.4*38.1*9.52 SC | | 25.4 | 38.1 | | 9.52 | |
| FSC9907NB | 25.4*38.1*9.53 TB | | 25.4 | 38.1 | | 9.53 | |
| FSC9986NB | 25.4*38.1*9.53 TC | | 25.4 | 38.1 | | 9.53 | |
| FSC9981NB | 25.4*38.1*9.93 SA | | 25.4 | 38.1 | | 9.93 | |
| FSC0442NB | 26.59*38.1*6.35 SC | 1.047*1.500*0.250 SC | 26.59 | 38.1 | | 6.35 | |
| FSC9932NB | 27*38.1*7.95 SB | | 27 | 38.1 | | 7.95 | |
| FSC0434NB | 28.4*38.1*6.4 SC | 1.120*1.500*0.252 SC | 28.4 | 38.1 | | 6.4 | |
| FSC0283NB | 28.57*38.1*6.35 SC | 1.125*1.500*0.250 SC | 28.57 | 38.1 | | 6.35 | |
| FSC9901NB | 28.58*38.1*6.35 SC | | 28.58 | 38.1 | | 6.35 | |
| FSC9962NB | 28.58*38.1*6.35 TC | 1.125*1.500*0.250 | 28.58 | 38.1 | | 6.35 | |
| FSC9955NB | 28.58*38.1*6.35 TZ | | 28.58 | 38.1 | | 6.35 | |
| FSC0379NB | 28.58*38.1*6.4 SC | 1.125*1.500*0.252 SC | 28.58 | 38.1 | | 6.4 | |
| FSC9925N0 | 31.75*38.1*3.96 VB | | 31.75 | 38.1 | | 3.96 | |
| FSC9903N0 | 31.75*38.1*3.96 VC | | 31.75 | 38.1 | | 3.96 | |
| FSC0364NB | 22.23*38.18*9.5 SC | 0.875*1.500*0.370 SC | 22.23 | 38.18 | | 9.5 | |
| FSC0371NB | 25.4*38.18*6.3 SC | 1.000*1.503*0.248 SC | 25.4 | 38.18 | | 6.3 | |
| FSC0370N0 | 27*38.18*6.3 VC | | 27 | 38.18 | | 6.3 | |
| FSC0953NB | 28*38.3*7.5 TBC4(NBR80) | BP6494E,WLK | 28 | 38.3 | | 7.5 | |
| FSC0184NB | 19*39*5 SB5Y Insert | | 19 | 39 | | 5 | |
| FSC0183NB | 19*39*5 SC | | 19 | 39 | | 5 | |
| FSC0782NB | 19*39*7 TC | | 19 | 39 | | 7 | |
| FSC0783NB | 20*39*6 TC | | 20 | 39 | | 6 | |
| FSC0097N0 | 21*39*10.5 軟(39.5) | | 21 | 39 | | 10.5 | |
| FSC0707NB | 22*39*6 TC | | 22 | 39 | | 6 | |
| FSC0786NB | 22*39*8 TC | | 22 | 39 | | 8 | |
| FSC0885NB | 22*39*10 TC | | 22 | 39 | | 10 | |
| FSC0787NB | 24*39*8 SC | | 24 | 39 | | 8 | |
| FSC0480NB | 25*39*7 TC | | 25 | 39 | | 7 | |
| FSC0002NB | 27*39*10.5 TB4 | 90756118003, 2762314551 | 27 | 39 | | 10.5 | |
| FSC0001NB | 27*39*10.5 TC4 | 27623-14500 | 27 | 39 | | 10.5 | |
| FSC0700NB | 28*39*5 SB | | 28 | 39 | | 5 | |
| FSC0658NB | 28*39*6 VB | | 28 | 39 | | 6 | |
| FSC0790NB | 28*39*7 SC | | 28 | 39 | | 7 | |
| FSC0114N0 | 29*39*4 VB | | 29 | 39 | | 4 | |
| FSC0898NB | 29*39*5 SC | | 29 | 39 | | 5 | |
| FSC0483NB | 30*39*7 TB | | 30 | 39 | | 7 | |
| FSC0504NB | 30*39*7 TC | | 30 | 39 | | 7 | |
| FSC0740NB | 32*39*6/8 VBY | | 32 | 39 | | 6 | 8 |
| FSC0685NB | 32*39*7 TZ | | 32 | 39 | | 7 | |
| FSC0411N0 | 34*39*3 KC | 60955 | 34 | 39 | | 3 | |
| FSC0690QB | 27*39.5*7 HTCR(VMQ) | R860012(Grey Brown) | 27 | 39.5 | | 7 | |
| FSC0261NB | 25.02*39.67*9.53 SB | 0.985*1.562*0.375 SB | 25.02 | 39.67 | | 9.53 | |

| WLK CODE | OIL SEALS | DESCRIPTION | ID | OD1 | OD2 | H1 | H2 |
|-----------|---------------------------|----------------------|-------|-------|-----|------|-----|
| FSC0265NB | 25.4*39.67*9.52 SB | 1.000*1.562*0.375 SB | 25.4 | 39.67 | | 9.52 | |
| FSC9920N0 | 25.4*39.7*4.76 VG | | 25.4 | 39.7 | | 4.76 | |
| FSC0443NB | 28.57*39.70*9.12 SC | 1.125*1.563*0.359 SC | 28.57 | 39.7 | | 9.12 | |
| FSC9910NB | 28.58*39.7*4.78 SC | | 28.58 | 39.7 | | 4.78 | |
| FSC9897NB | 28.58*39.7*6.35 TC | | 28.58 | 39.7 | | 6.35 | |
| FSC9971NB | 28.58*39.7*7.95 TC | | 28.58 | 39.7 | | 7.95 | |
| FSC9926NB | 28.58*39.7*9.53 TC | | 28.58 | 39.7 | | 9.53 | |
| FSC0415NB | 17*39.9*5 TB2 | 38 | 17 | 39.9 | | 5 | |
| FSC0381NB | 15*40*7 TC | | 15 | 40 | | 7 | |
| FSC0814NB | 15*40*8 TC | | 15 | 40 | | 8 | |
| FSC0719NB | 15*40*10 SB | | 15 | 40 | | 10 | |
| FSC0640NB | 15*40*10 SC | | 15 | 40 | | 10 | |
| FSC0522NB | 15*40*10 TC | | 15 | 40 | | 10 | |
| FSC0523NB | 16*40*7 TC | | 16 | 40 | | 7 | |
| FSC0874NB | 16*40*7 Y(NBR60)SUSINSERT | | 16 | 40 | | 7 | |
| FSC0880NB | 16*40*8 SC | | 16 | 40 | | 8 | |
| FSC0771NB | 16*40*8 TC | | 16 | 40 | | 8 | |
| FSC0837NB | 16*40*10 TC | | 16 | 40 | | 10 | |
| FSC0316NB | 16.9*40*5 SC | | 16.9 | 40 | | 5 | |
| FSC0423NB | 17*40*5 TB2 | 60S (BIG) | 17 | 40 | | 5 | |
| FSC0327NB | 17*40*5 TC | | 17 | 40 | | 5 | |
| FSC0852NB | 17*40*6 SC | | 17 | 40 | | 6 | |
| FSC0762NB | 17*40*6 TC | | 17 | 40 | | 6 | |
| FSC0323NB | 17*40*7 DC (Green) | 17*40*7/01 DC | 17 | 40 | | 7 | |
| FSC0318NB | 17*40*7 SC | 3170126 | 17 | 40 | | 7 | |
| FSC0325NB | 17*40*7 TC | | 17 | 40 | | 7 | |
| FSC0315NB | 17*40*8 TC | | 17 | 40 | | 8 | |
| FSC0406NB | 17*40*10 TC | | 17 | 40 | | 10 | |
| FSC0326N0 | 17*40*10/12 KC | | 17 | 40 | | 10 | 12 |
| FSC0524NB | 18*40*7 TC | | 18 | 40 | | 7 | |
| FSC0854NB | 18*40*8 TC | | 18 | 40 | | 8 | |
| FSC0390NB | 18*40*10 TC | | 18 | 40 | | 10 | |
| FSC0362NB | 19*40*7 TC | | 19 | 40 | | 7 | |
| FSC0518NB | 19*40*10 SC | | 19 | 40 | | 10 | |
| FSC0731NB | 19*40*10 TC | | 19 | 40 | | 10 | |
| FSC0644NB | 20*40*4 SC | | 20 | 40 | | 4 | |
| FSC0862NB | 20*40*5 TC | | 20 | 40 | | 5 | |
| FSC0088NB | 20*40*6 TC | | 20 | 40 | | 6 | |
| FSC0813NB | 20*40*7 DC | | 20 | 40 | | 7 | |
| FSC0329NB | 20*40*7 SB5 | | 20 | 40 | | 7 | |
| FSC0321NB | 20*40*7 SC | | 20 | 40 | | 7 | |
| FSC0321FB | 20*40*7 SC(VITON) | TC修掉副唇 | 20 | 40 | | 7 | |
| FSC0311NB | 20*40*7 TB(Blue) | 653B204007 | 20 | 40 | | 7 | |
| FSC0314NB | 20*40*7 TC | 113LG43 | 20 | 40 | | 7 | |
| FSC0314FB | 20*40*7 TC(VITON) | | 20 | 40 | | 7 | |
| FSC0314QB | 20*40*7 TC(VMQ) | | 20 | 40 | | 7 | |
| FSC0847NB | 20*40*7/7.5 TCV | | 20 | 40 | | 7 | 7.5 |
| FSC0313NB | 20*40*7/9 TCY | | 20 | 40 | | 7 | 9 |
| FSC0832NB | 20*40*8 TB | | 20 | 40 | | 8 | |
| FSC0312NB | 20*40*8 TC | 93102-20447 | 20 | 40 | | 8 | |
| FSC0319NB | 20*40*9 DC | | 20 | 40 | | 9 | |
| FSC0310NB | 20*40*9 SC | | 20 | 40 | | 9 | |
| FSC0322NB | 20*40*9 TC | | 20 | 40 | | 9 | |
| FSC0496NB | 20*40*10 TC | 113LG10 | 20 | 40 | | 10 | |
| FSC0496FB | 20*40*10 TC(VITON) | | 20 | 40 | | 10 | |
| FSC0496QB | 20*40*10 TC(VMQ) | | 20 | 40 | | 10 | |
| FSC0309NB | 20*40*11 SC | | 20 | 40 | | 11 | |

| WLK CODE | OIL SEALS | DESCRIPTION | ID | OD1 | OD2 | H1 | H2 |
|-----------|--------------------------|-------------------------|------|-----|-----|-----|------|
| FSC0331NB | 21*40*7 TC | Ardo Merloni, Blomberg, | 21 | 40 | | 7 | |
| FSC0563NB | 21*40*10 TC | | 21 | 40 | | 10 | |
| FSC0332QB | 21.9*40*8 DGS (ACM) | 020 311 113(HTCRG) | 21.9 | 40 | | 8 | |
| FSC0914NB | 22*40*5 SC | | 22 | 40 | | 5 | |
| FSC0324NB | 22*40*7 DC(Green) | 22*40*7/01 DC | 22 | 40 | | 7 | |
| FSC0005NB | 22*40*7 HSCL Green | | 22 | 40 | | 7 | |
| FSC0883NB | 22*40*7 SC | | 22 | 40 | | 7 | |
| FSC0334NB | 22*40*7 TC | 03AT53 | 22 | 40 | | 7 | |
| FSC0334FB | 22*40*7 TC(VITON) | | 22 | 40 | | 7 | |
| FSC0288N0 | 22*40*7 VB | | 22 | 40 | | 7 | |
| FSC0082NB | 22*40*8 TC | | 22 | 40 | | 8 | |
| FSC0082QB | 22*40*8 TC(VMQ) | | 22 | 40 | | 8 | |
| FSC0335NB | 22*40*8/11.5 TCY | 113LG11 | 22 | 40 | | 8 | 11.5 |
| FSC0694NB | 22*40*8/11.5 TGY | 03AT07 | 22 | 40 | | 8 | 11.5 |
| FSC0463NB | 22*40/51*8/12 TG5Y | 113ZN01 | 22 | 40 | 51 | 8 | 12 |
| FSC0372NB | 22*40*8.5 DC | NBR 80度 113AR07 | 22 | 40 | | 8.5 | |
| FSC0454NB | 22*40/66*9/14.5 Y | 113ZN03 | 22 | 40 | 66 | 9 | 14.5 |
| FSC0526NB | 22*40*10 DC | | 22 | 40 | | 10 | |
| FSC0475NB | 22*40*10 TC | 113LG139 | 22 | 40 | | 10 | |
| FSC0475FB | 22*40*10 TC(FKM)VITON | | 22 | 40 | | 10 | |
| FSC0538NB | 22*40*10/11.5 TGY | 03AT34 | 22 | 40 | | 10 | 11.5 |
| FSC0801NB | 22*40*12 TC | | 22 | 40 | | 12 | |
| FSC0938NB | 22*40*12/17 HTCYR | | 22 | 40 | | 12 | 17 |
| FSC0540N0 | 23*40*4 KC | | 23 | 40 | | 4 | |
| FSC0940NB | 23*40*5 TC | | 23 | 40 | | 5 | |
| FSC0915NB | 23*40*6 TC | | 23 | 40 | | 6 | |
| FSC0546NB | 23*40*7 HTCL | 80672-3010/11 | 23 | 40 | | 7 | |
| FSC0546QB | 23*40*7 HTCL(VMQ) | | 23 | 40 | | 7 | |
| FSC0478NB | 23*40*7 TB | | 23 | 40 | | 7 | |
| FSC0505NB | 23*40*7 TC | | 23 | 40 | | 7 | |
| FSC0633NB | 23*40*8 SC | | 23 | 40 | | 8 | |
| FSC0420NB | 23*40*8 TC | | 23 | 40 | | 8 | |
| FSC0420FB | 23*40*8 TC(VITON) | | 23 | 40 | | 8 | |
| FSC0634NB | 23*40*10 TC | | 23 | 40 | | 10 | |
| FSC0683NB | 24*40*7 SC | | 24 | 40 | | 7 | |
| FSC0683NS | 24*40*7 SC(S304 SPRING) | | 24 | 40 | | 7 | |
| FSC0410NB | 24*40*7 TC | D350-1508-40 | 24 | 40 | | 7 | |
| FSC0410FB | 24*40*7 TC(VITON) | | 24 | 40 | | 7 | |
| FSC0760N0 | 24*40*7.3/9.5 VCY(BROWN) | CIVIC K8 96-01 | 24 | 40 | | 7.3 | 9.5 |
| FSC0308NB | 24*40*8 TC | NM65 起動 0613-16-103 | 24 | 40 | | 8 | |
| FSC0916NB | 24*40*10 SC | | 24 | 40 | | 10 | |
| FSC0798NB | 24*40*10 TC | | 24 | 40 | | 10 | |
| FSC0917NB | 24.5*40*8.5 SC | | 24.5 | 40 | | 8.5 | |
| FSC0307NB | 25*40*5 TC | MF150/MF180 | 25 | 40 | | 5 | |
| FSC0306NB | 25*40*6 SC | | 25 | 40 | | 6 | |
| FSC0305NB | 25*40*7 TB | 48137-26760 | 25 | 40 | | 7 | |
| FSC0304NB | 25*40*7 TC | KF53, 09283-25035 | 25 | 40 | | 7 | |
| FSC0304FS | 25*40*7 TC (FKM)S304 | VITON+S304 SPRING | 25 | 40 | | 7 | |
| FSC0304QB | 25*40*7 TC (VMQ) | | 25 | 40 | | 7 | |
| FSC0419NB | 25*40*7.5/8.9 TC6Y | NP85 | 25 | 40 | | 7.5 | 8.9 |
| FSC0548NB | 25*40*7.5/9.5 TF | 彈簧內包 | 25 | 40 | | 7.5 | 9.5 |
| FSC0418NB | 25*40*7.5/9.8 KCY | NBR80 | 25 | 40 | | 7.5 | 9.8 |
| FSC0338NB | 25*40*8 DC | 機車用 | 25 | 40 | | 8 | |
| FSC0339NS | 25*40*8 SC(S304 SPRING) | F25-2503-0 | 25 | 40 | | 8 | |
| FSC0339FB | 25*40*8 SC(VITON) | | 25 | 40 | | 8 | |
| FSC0817NB | 25*40*8 TB(TM) | | 25 | 40 | | 8 | |
| FSC0303NB | 25*40*8 TC | 32113-M8000 | 25 | 40 | | 8 | |

| WLK CODE | OIL SEALS | DESCRIPTION | ID | OD1 | OD2 | H1 | H2 |
|------------|---------------------------|--------------------------|------|-----|-----|------|----|
| FSC0303AB | 25*40*8 TC(ACM) | | 25 | 40 | | 8 | |
| FSC0303NS | 25*40*8 TC(S304 SPRING) | | 25 | 40 | | 8 | |
| FSF0303FB | 25*40*8 TC(VITON) | | 25 | 40 | | 8 | |
| FSC0287N0 | 25*40*8 VC(25*40*5/7.7Y) | 怪型WLK | 25 | 40 | | 8 | |
| FSC0861FB | 25*40*9 SC(FKM)VITON | TC副唇修掉變SC | 25 | 40 | | 9 | |
| FSC0302NB | 25*40*9 TC | | 25 | 40 | | 9 | |
| FSC0302FB | 25*40*9 TC(FKM)VITON | | 25 | 40 | | 9 | |
| FSC0947FB | 25*40*10 SC(VITON) | | 25 | 40 | | 10 | |
| FSC0301NB | 25*40*10 TC | AE1315-FO | 25 | 40 | | 10 | |
| FSC0301FB | 25*40*10 TC(VITON) | | 25 | 40 | | 10 | |
| FSC0301QB | 25*40*10 TC(VMQ) | | 25 | 40 | | 10 | |
| FSC0081FB | 25*40*12 TC(VITON) | | 25 | 40 | | 12 | |
| FSC0300NB | 25*40*12 TC5Y | 三菱MP660/MP(插)前輪軸 | 25 | 40 | | 12 | |
| FSC0299NB | 26*40*5 SC | NT85/95/TS155/TS180起動 | 26 | 40 | | 5 | |
| FSC0298NB | 26*40*6 TC | TS180 起動STARTING | 26 | 40 | | 6 | |
| FSC0726NB | 26*40*7 HTCR | | 26 | 40 | | 7 | |
| FSC0382NB | 26*40*7 TC | 48137-36700 | 26 | 40 | | 7 | |
| FSC0542NB | 26*40*8 TC | | 26 | 40 | | 8 | |
| FSC0094NB | 26.5*40*7 HSC (VMQ)White | CP-MATIC GERMANY | 26.5 | 40 | | 7 | |
| FSC0345NB | 27*40*6 SC | | 27 | 40 | | 6 | |
| FSC0084NB | 27*40*6/7 HTCR | | 27 | 40 | | 6 | 7 |
| FSC0297NB | 27*40*7 TC | 久保 20H 起動09550-27407 | 27 | 40 | | 7 | |
| FSC0467NB | 27*40*8 HTCL | 9828-27102 | 27 | 40 | | 8 | |
| FSC0482NB | 27*40*8 TC | | 27 | 40 | | 8 | |
| FSC0482FB | 27*40*8 TC(VITON) | | 27 | 40 | | 8 | |
| FSC0639NB | 27*40*10 TC | | 27 | 40 | | 10 | |
| FSC0513NB | 28*40*5 SB | | 28 | 40 | | 5 | |
| FSC0296NB | 28*40*5 SC | | 28 | 40 | | 5 | |
| FSC0085NB | 28*40*5 TC | | 28 | 40 | | 5 | |
| FSC0515N0 | 28*40*5 VB | | 28 | 40 | | 5 | |
| FSC0342NB | 28*40*6 SC | | 28 | 40 | | 6 | |
| FSC0549NB | 28*40*7 HSCG | | 28 | 40 | | 7 | |
| FSC0549NSS | 28*40*7 HSCG(S304+INSERT) | (SUS304 SPRING+INSERT) | 28 | 40 | | 7 | |
| FSC0343NB | 28*40*7 SC | | 28 | 40 | | 7 | |
| FSC0343NSS | 28*40*7 SC(SUS304+INSERT) | 96104182 | 28 | 40 | | 7 | |
| FSC0343FB | 28*40*7 SC(VITON) | TC修掉副唇 | 28 | 40 | | 7 | |
| FSC0343QB | 28*40*7 SC(VMQ) | | 28 | 40 | | 7 | |
| FSC0402NB | 28*40*7 TC | | 28 | 40 | | 7 | |
| FSC0402NSS | 28*40*7 TC(SUS304+INSERT) | | 28 | 40 | | 7 | |
| FSC0402FB | 28*40*7 TC(VITON) | | 28 | 40 | | 7 | |
| FSC0295NB | 28*40*8 DC | 93103-28011 | 28 | 40 | | 8 | |
| FSC0539NB | 28*40*8 HTCR | MD-008883 | 28 | 40 | | 8 | |
| FSC0347NB | 28*40*8 SB | 49321-Y0100 | 28 | 40 | | 8 | |
| FSC0730NB | 28*40*8 SC | | 28 | 40 | | 8 | |
| FSC0344NB | 28*40*8 TB | 90310-28027/28072 | 28 | 40 | | 8 | |
| FSC0294NB | 28*40*8 TC | 32113-86401, 93103-26011 | 28 | 40 | | 8 | |
| FSC0346NB | 28*40*8/6 TCY | | 28 | 40 | | 8 | 6 |
| FSC0871NB | 28*40*9 TC | | 28 | 40 | | 9 | |
| FSC0827NB | 28*40*10 DC | | 28 | 40 | | 10 | |
| FSC0449NB | 28*40*10 TC | | 28 | 40 | | 10 | |
| FSC0449FB | 28*40*10 TC(VITON) | | 28 | 40 | | 10 | |
| FSC0348NB | 28*40*10.5 TB4 | | 28 | 40 | | 10.5 | |
| FSC0723NB | 28.6*40*8 TC | | 28.6 | 40 | | 8 | |
| FSC0714NB | 29*40*6 SB | | 29 | 40 | | 6 | |
| FSC0714FB | 29*40*6 SB(VITON) | | 29 | 40 | | 6 | |
| FSC0485NB | 29*40*7 SC | | 29 | 40 | | 7 | |

| WLK CODE | OIL SEALS | DESCRIPTION | ID | OD1 | OD2 | H1 | H2 |
|-----------|--------------------------|-------------------------|-------|-------|------|------|------|
| FSC0732NB | 29*40*7 TC | | 29 | 40 | | 7 | |
| FSC0732FB | 29*40*7 TC(VITON) | | 29 | 40 | | 7 | |
| FSC0752NB | 29*40*8 TC | | 29 | 40 | | 8 | |
| FSD0455PB | 29.7*40*7 TCJ PTFE | | 29.7 | 40 | | 7 | |
| FSC0427NB | 29.8*40*7 TC4 | | 29.8 | 40 | | 7 | |
| FSC0878NB | 30*40*4 TC | | 30 | 40 | | 4 | |
| FSC0737N0 | 30*40*4 VB | | 30 | 40 | | 4 | |
| FSC0886N0 | 30*40*4 VC | | 30 | 40 | | 4 | |
| FSC0687NB | 30*40*4 VG | | 30 | 40 | | 4 | |
| FSC0293NB | 30*40*5 SC | | 30 | 40 | | 5 | |
| FSC0558NB | 30*40*5 TC | | 30 | 40 | | 5 | |
| FSC0864N0 | 30*40*5 VC | | 30 | 40 | | 5 | |
| FSC0428NB | 30*40*6 TC | | 30 | 40 | | 6 | |
| FSC0529NB | 30*40*6/8.8 TCY Black | 50002-31051 | 30 | 40 | | 6 | 8.8 |
| FSC0350NB | 30*40*7 HSCR | | 30 | 40 | | 7 | |
| FSC0350FB | 30*40*7 HSCR (FKM) | | 30 | 40 | | 7 | |
| FSC0350AB | 30*40*7 HSCR(ACM) | | 30 | 40 | | 7 | |
| FSC0689QB | 30*40*7 HTGL(VMQ)Red | R860013 Left | 30 | 40 | | 7 | |
| FSC0351NB | 30*40*7 HTGR(FKM+S304SPR | 018 997 79 47A VITON | 30 | 40 | | 7 | |
| FSC0351QB | 30*40*7 HTGR(VMQ) Brown | R860013 Right | 30 | 40 | | 7 | |
| FSC0624NB | 30*40*7 SB | 90310-30035 | 30 | 40 | | 7 | |
| FSC0624FB | 30*40*7 SB(VITON) | | 30 | 40 | | 7 | |
| FSC0320NB | 30*40*7 SC | 90310-30035,113LG53 | 30 | 40 | | 7 | |
| FSC0320FB | 30*40*7 SC(VITON)FKM | | 30 | 40 | | 7 | |
| FSC0560NB | 30*40*7 TB | | 30 | 40 | | 7 | |
| FSC0292NB | 30*40*7 TC | | 30 | 40 | | 7 | |
| FSC0292FB | 30*40*7 TC (VITON) | FKM | 30 | 40 | | 7 | |
| FSC0292QB | 30*40*7 TC (VMQ) | | 30 | 40 | | 7 | |
| FSC0765N0 | 30*40*7/10 GA | | 30 | 40 | | 7 | 10 |
| FSC0353NB | 30*40*8 TC | | 30 | 40 | | 8 | |
| FSC0491NB | 30*40*8 TC6(TC6Y) | 2186-738-0350-T | 30 | 40 | | 8 | |
| FSC0403NB | 30*40*10 TC | | 30 | 40 | | 10 | |
| FSC0403NS | 30*40*10 TC(S304 SPRING) | SUS304 SPRING | 30 | 40 | | 10 | |
| FSC0291NB | 30*40*10.5 TB4 | 5115308010, 13723-14501 | 30 | 40 | | 10.5 | |
| FSC0290N0 | 30*40*17/24.5 VCY | YZC HOLDER | 30 | 40 | | 17 | 24.5 |
| FSC0911NB | 32*40*4/7 DP8 | | 32 | 40 | | 4 | 7 |
| FSC0536NB | 32*40*5 SB | | 32 | 40 | | 5 | |
| FSC0069NB | 32*40*5 SC | | 32 | 40 | | 5 | |
| FSC0828N0 | 32*40*5 VC | 90312-32002 | 32 | 40 | | 5 | |
| FSC0673NB | 32*40*6 TC | | 32 | 40 | | 6 | |
| FSC0612NB | 32*40*7 TC | | 32 | 40 | | 7 | |
| FSC0612FB | 32*40*7 TC(VITON) | | 32 | 40 | | 7 | |
| FSC0511NB | 32*40*8 TC | | 32 | 40 | | 8 | |
| FSC0511FB | 32*40*8 TC(VITON) | | 32 | 40 | | 8 | |
| FSC0956NB | 32*40*10 TC | | 32 | 40 | | 10 | |
| FSC0805N0 | 33*40*3 VB | | 33 | 40 | | 3 | |
| FSC0904NB | 33*40*3.5/6.5 SCY | | 33 | 40 | | 3.5 | 6.5 |
| FSC0812NB | 33*40*6.5 SCY | | 33 | 40 | | 6.5 | |
| FSC0792NB | 35*40*4 VC | | 35 | 40 | | 4 | |
| FSD9968NB | 23.5*40.5*6.7 Y1(軟) | 12342-PM6-000 | 23.5 | 40.5 | | 6.7 | |
| FSD0869NB | 24.61*40.5/48.5*3.2/9 Y | 28218-26D09 | 24.61 | 40.5 | 48.5 | 3.2 | 9 |
| FSD0900NB | 30*40.5*10.5 DC | | 30 | 40.5 | | 10.5 | |
| FSD0088NB | 30*40.5*10.5 TB4 | | 30 | 40.5 | | 10.5 | |
| FSD0087NB | 30*40.5*10.5 TC4 | TR/GP | 30 | 40.5 | | 10.5 | |
| FSC0422NB | 30*40.5*10.5 TC4 | 137-23145-01 | 30 | 40.5 | | 10.5 | |
| FSD0600NB | 29.8*40.65*5/12 Y(NP75) | KCKG0008 | 29.8 | 40.65 | | 5 | 12 |

| WLK CODE | OIL SEALS | DESCRIPTION | ID | OD1 | OD2 | H1 | H2 |
|-----------|------------------------------------|--------------------------|--------|--------|-----|-------|-----|
| FSD0164NB | 20*41*7 TC | | 20 | 41 | | 7 | |
| FSD0787NB | 22*41*6 TC | | 22 | 41 | | 6 | |
| FSD0086NB | 25*41*6 TC | G150/200/300, GX160 | 25 | 41 | | 6 | |
| FSD0629NB | 25*41*7 TB | | 25 | 41 | | 7 | |
| FSD0085NB | 25*41*7 TC | | 25 | 41 | | 7 | |
| FSD0586NB | 26*41*7 HTCL | 91216-PH8-0031/5 | 26 | 41 | | 7 | |
| FSD0161NB | 26*41*7 TZ | | 26 | 41 | | 7 | |
| FSD0645NB | 27*41*10 SC | | 27 | 41 | | 10 | |
| FSD0709NB | 27*41*10 TC | | 27 | 41 | | 10 | |
| FSD0220NB | 28*41*6 TC | K7 | 28 | 41 | | 6 | |
| FSD0659NB | 28*41*7 HTCL | 91216-PH8-003 | 28 | 41 | | 7 | |
| FSD0598NB | 28*41*7 TB | | 28 | 41 | | 7 | |
| FSD0882NB | 28*41*7 TC | | 28 | 41 | | 7 | |
| FSD0221NB | 28*41*9.4 SB | | 28 | 41 | | 9.4 | |
| FSD0222NB | 28*41*10.5 TB4 | | 28 | 41 | | 10.5 | |
| FSD0514NB | 29*41*7 TB | | 29 | 41 | | 7 | |
| FSD0533NB | 29*41*7 TC | | 29 | 41 | | 7 | |
| FSD0566NB | 29*41*7 TZ | | 29 | 41 | | 7 | |
| FSD0096N0 | 30*41*5/7 VCY | | 30 | 41 | | 5 | 7 |
| FSD0304NB | 30*41*7 TC | | 30 | 41 | | 7 | |
| FSD0649NB | 30*41*8 TC | BH2825E | 30 | 41 | | 8 | |
| FSD0580NB | 30*41*10 HTBL | 90043-11098 | 30 | 41 | | 10 | |
| FSD0108N0 | 31*41*4/4.5 VCY | | 31 | 41 | | 4 | 4.5 |
| FSD0805NB | 31*41*6 TC(BROWN) | | 31 | 41 | | 6 | |
| FSD0940NB | 34*41*4 TC4 | | 34 | 41 | | 4 | |
| FSD0442NB | 35*41*5.5/9 SCY | 90310-35001, T1008 | 35 | 41 | | 5.5 | 9 |
| FSD9983NB | 25.4*41.14*6.35 TC | 1.000*1.620*0.250 TC | 25.4 | 41.14 | | 6.35 | |
| FSD0429NB | 20.96*41.20*4.93 SC(BH6) | 0.825*1.622*0.195 SC | 20.96 | 41.2 | | 4.93 | |
| FSD0215NB | 20*41.25*7 TC(BROWN) | | 20 | 41.25 | | 7 | |
| FSD0126NB | 22*41.25*7 TB | EY13/14 (ROBIN) | 22 | 41.25 | | 7 | |
| FSD0084NB | 22*41.25*7 TC | GX110 BIG, GX120;GX160 | 22 | 41.25 | | 7 | |
| FSD9914NB | 22.23*41.25*6.35 TB | | 22.23 | 41.25 | | 6.35 | |
| FSD0083NB | 25*41.25*6 TC | GX140/160,G150 | 25 | 41.25 | | 6 | |
| FSD0082NB | 25*41.25*7 TB(TM) | EY15/18/20 (ROBIN)(IRON) | 25 | 41.25 | | 7 | |
| FSD0124NB | 25*41.25*7 TC | EY15 BIG(RUBBER) | 25 | 41.25 | | 7 | |
| FSD9913NB | 25.4*41.25*6.35 SBP Green Painting | NBR80内徑束2MM | 25.4 | 41.25 | | 6.35 | |
| FSD9908NB | 25.4*41.25*6.35 TB | | 25.4 | 41.25 | | 6.35 | |
| FSD0105NB | 28*41.25*9.4 SB (Red) | | 28 | 41.25 | | 9.4 | |
| FSD9950NB | 28.575*41.275*6.35 TBP | 1.125*1.625*0.250 TBP | 28.575 | 41.275 | | 6.35 | |
| FSD9947NB | 19.05*41.28*6.35 TB | | 19.05 | 41.28 | | 6.35 | |
| FSD9947FB | 19.05*41.28*6.35 TB(FKM) | VITON | 19.05 | 41.28 | | 6.35 | |
| FSD9965NB | 19.05*41.28*6.35 TC | | 19.05 | 41.28 | | 6.35 | |
| FSD9965FB | 19.05*41.28*6.35 TC(FKM) | VITON | 19.05 | 41.28 | | 6.35 | |
| FSD0170NB | 20.64*41.28*6.35 TC | 0.8125*1.625*0.250 TC | 20.64 | 41.28 | | 6.35 | |
| FSD9997NB | 20.65*41.28*4.78 VC | 293740 | 20.65 | 41.28 | | 4.78 | |
| FSD0109N0 | 20.7*41.28*4.75 VC | 0.815*1.625*0.187 VC | 20.7 | 41.28 | | 4.75 | |
| FSD9927NB | 22.23*41.28*7.95 SB | | 22.23 | 41.28 | | 7.95 | |
| FSD9994NB | 22.23*41.28*9.53 SC | 0.875*1.625*0.375 SC | 22.23 | 41.28 | | 9.53 | |
| FSB9944NB | 22.23*41.28*11.13 SB | | 22.23 | 41.28 | | 11.13 | |
| FSD9912NB | 24.61*41.28*7.95 TB | | 24.61 | 41.28 | | 7.95 | |
| FSD0114N0 | 25.4*41.28*4.7 VC | 1.000*1.625*0.185 VC | 25.4 | 41.28 | | 4.7 | |
| FSD9978NB | 25.4*41.28*6.35 TB | | 25.4 | 41.28 | | 6.35 | |
| FSD9964NB | 25.4*41.28*6.35 TC | 1.000*1.625*0.250 | 25.4 | 41.28 | | 6.35 | |
| FSD9964FB | 25.4*41.28*6.35 TC(VITON) | 1.000*1.625*0.250VITON | 25.4 | 41.28 | | 6.35 | |
| FSD9986NB | 25.4*41.28*6.4 TC | 1.000*1.625*0.250 TC | 25.4 | 41.28 | | 6.4 | |
| FSD9944NB | 25.4*41.28*7.95 TC | | 25.4 | 41.28 | | 7.95 | |
| FSD9958NB | 25.4*41.28*9.53 TC | | 25.4 | 41.28 | | 9.53 | |

| WLK CODE | OIL SEALS | DESCRIPTION | ID | OD1 | OD2 | H1 | H2 |
|-----------|---------------------------|----------------------|-------|-------|-----|------|----|
| FSD9939NB | 27.79*41.28*6.35 SBAY | 白灰殼 | 27.79 | 41.28 | | 6.35 | |
| FSD9896NB | 28.58*41.28*6.35 HSBR | (HSMR) | 28.58 | 41.28 | | 6.35 | |
| FSD9919NB | 28.58*41.28*6.35 SB | | 28.58 | 41.28 | | 6.35 | |
| FSD9924NB | 28.58*41.28*6.35 SC | | 28.58 | 41.28 | | 6.35 | |
| FSD9943NB | 28.58*41.28*6.35 TC | 1.125*1.625*0.250 TC | 28.58 | 41.28 | | 6.35 | |
| FSD9899NB | 28.58*41.28*6.35 TM | | 28.58 | 41.28 | | 6.35 | |
| FSD0209NB | 28.58*41.28*9.53 SB | 1.125*1.625*0.375 SB | 28.58 | 41.28 | | 9.53 | |
| FSD9936NB | 28.58*41.28*9.53 SC | | 28.58 | 41.28 | | 9.53 | |
| FSD9936FB | 28.58*41.28*9.53 SC(VITO) | VITON | 28.58 | 41.28 | | 9.53 | |
| FSD9985NB | 28.58*41.28*9.53 TB(TZ) | | 28.58 | 41.28 | | 9.53 | |
| FSD9979NB | 28.58*41.28*9.53 TC | 1.125*1.625*0.375 TC | 28.58 | 41.28 | | 9.53 | |
| FSD9941NB | 31.75*41.28*4.78 TC | | 31.75 | 41.28 | | 4.78 | |
| FSD9909NB | 31.75*41.28*6.35 TC | | 31.75 | 41.28 | | 6.35 | |
| FSD0141NB | 22*41.3*6 SC | K91 用 | 22 | 41.3 | | 6 | |
| FSD0179NB | 22*41.3*6 TA(VA) | K4 | 22 | 41.3 | | 6 | |
| FSD0100NB | 25*41.3*8 TC | L40 / L60 用 | 25 | 41.3 | | 8 | |
| FSD0369NB | 28*41.3*9.3 SB(SM) | | 28 | 41.3 | | 9.3 | |
| FSD0369QB | 28*41.3*9.3 SB(SM)(VMQ) | 藍色 | 28 | 41.3 | | 9.3 | |
| FSD0157N0 | 29.21*41.33*6.35 KC | 1.150*1.627*0.250 KC | 29.21 | 41.33 | | 6.35 | |
| FSD0143N0 | 28.5*41.4*6.35 KC | 1.122*1.629*0.250 KC | 28.5 | 41.4 | | 6.35 | |
| FSD0173NB | 21*41.5*5 TB | B/S 3HP | 21 | 41.5 | | 5 | |
| FSD0081NB | 25*41.5*10 TC | | 25 | 41.5 | | 10 | |
| FSD0224NB | 28*41.5*9.4 SB Red | | 28 | 41.5 | | 9.4 | |
| FSD0374NB | 15*42*7 TC | | 15 | 42 | | 7 | |
| FSD0374FB | 15*42*7 TC(VITON) | | 15 | 42 | | 7 | |
| FSD0159NB | 15*42*8 TC | | 15 | 42 | | 8 | |
| FSD0676NB | 15*42*10 SA | | 15 | 42 | | 10 | |
| FSD0676FB | 15*42*10 SA(FKM)VITON | | 15 | 42 | | 10 | |
| FSD0861NB | 15*42*10 TA | | 15 | 42 | | 10 | |
| FSD0862NB | 15*42*10 TB | | 15 | 42 | | 10 | |
| FSD0856FB | 15*42*10 TC(VITON) | | 15 | 42 | | 10 | |
| FSD0674NB | 17*42*7 TC | | 17 | 42 | | 7 | |
| FSD0080NB | 17*42*8 TC | | 17 | 42 | | 8 | |
| FSD0752NB | 18*42*7 TC | | 18 | 42 | | 7 | |
| FSD0784NB | 18*42*8 SC | | 18 | 42 | | 8 | |
| FSD0741NB | 19*42*7 TC | | 19 | 42 | | 7 | |
| FSD0911NB | 20*42*6 SC | | 20 | 42 | | 6 | |
| FSD0851NB | 20*42*6 TC(BLUE) | | 20 | 42 | | 6 | |
| FSD0165NB | 20*42*7 SC | | 20 | 42 | | 7 | |
| FSD0368NB | 20*42*7 TC | | 20 | 42 | | 7 | |
| FSD0368FB | 20*42*7 TC (VITON) | | 20 | 42 | | 7 | |
| FSD0368QB | 20*42*7 TC (VMQ) | | 20 | 42 | | 7 | |
| FSD0079NB | 20*42*8 TC | 93102-20371 | 20 | 42 | | 8 | |
| FSD0079FB | 20*42*8 TC(VITON) | | 20 | 42 | | 8 | |
| FSD0428NB | 20*42/43*8/9 HTCL Green | 478-1508-40 | 20 | 42 | 43 | 8 | 9 |
| FSD0166NB | 20*42*10 SA2 | | 20 | 42 | | 10 | |
| FSD0492NB | 20*42*10 TC | | 20 | 42 | | 10 | |
| FSD0078NB | 20*42*12 TC6(TCU) | | 20 | 42 | | 12 | |
| FSD0380NB | 22*42*7 TC | | 22 | 42 | | 7 | |
| FSD0115NB | 22*42*8 TC | | 22 | 42 | | 8 | |
| FSD0821NB | 22*42*10 TB | | 22 | 42 | | 10 | |
| FSD0378NB | 22*42*10 TC | | 22 | 42 | | 10 | |
| FSD0378FS | 22*42*10 TC(FKM)S304 | VITON(S304 SPRING) | 22 | 42 | | 10 | |
| FSD0378NS | 22*42*10 TC(S304 SPRING) | | 22 | 42 | | 10 | |
| FSD0658NB | 22*42*11 TC | | 22 | 42 | | 11 | |
| FSD0872NB | 22*42*11/12 TC4Y(NBR65) | Special seals | 22 | 42 | | 11 | 12 |
| FSD0886NB | 23*42*6 TC | | 23 | 42 | | 6 | |

| WLK CODE | OIL SEALS | DESCRIPTION | ID | OD1 | OD2 | H1 | H2 |
|-----------|-------------------------|------------------|------|-----|-----|------|-----|
| FSD0636NB | 23*42*7 HTCL | | 23 | 42 | | 7 | |
| FSD0447NO | 23*42*7 KC3 | (FS104) | 23 | 42 | | 7 | |
| FSD0425NB | 23*42*7 TC | | 23 | 42 | | 7 | |
| FSD0562NB | 23*42*10 TC | | 23 | 42 | | 10 | |
| FSD0176NB | 24*42*6 TC | | 24 | 42 | | 6 | |
| FSD0076NB | 24*42*7 TC | | 24 | 42 | | 7 | |
| FSD0140NB | 24*42*8 TC | | 24 | 42 | | 8 | |
| FSD0818NB | 24*42*10 TC | | 24 | 42 | | 10 | |
| FSD0826NB | 25*42*5 TC | | 25 | 42 | | 5 | |
| FSD0654NB | 25*42*6 TC | | 25 | 42 | | 6 | |
| FSD0881NB | 25*42*6/6.5 TCV | | 25 | 42 | | 6 | 6.5 |
| FSD0673NB | 25*42*7 HTCL | | 25 | 42 | | 7 | |
| FSD0673AB | 25*42*7 HTCL(ACM) | | 25 | 42 | | 7 | |
| FSD0328NB | 25*42*7 SC | 113LG13 | 25 | 42 | | 7 | |
| FSD0328FB | 25*42*7 SC (FKM)VITON | | 25 | 42 | | 7 | |
| FSD0328NS | 25*42*7 SC(S304 SPRING) | | 25 | 42 | | 7 | |
| FSD0191NB | 25*42*7 TC | | 25 | 42 | | 7 | |
| FSD0191FB | 25*42*7 TC(VITON) | | 25 | 42 | | 7 | |
| FSD0693NB | 25*42*8 SC | | 25 | 42 | | 8 | |
| FSD0075NB | 25*42*8 TC | | 25 | 42 | | 8 | |
| FSD0075FB | 25*42*8 TC(VITON) | | 25 | 42 | | 8 | |
| FSD0075QB | 25*42*8 TC(VMQ) | | 25 | 42 | | 8 | |
| FSD0074NB | 25*42*9 SC | | 25 | 42 | | 9 | |
| FSD0662NB | 25*42*9 TC | | 25 | 42 | | 9 | |
| FSD0073NB | 25*42*10 SC | | 25 | 42 | | 10 | |
| FSD0192NB | 25*42*10 TB | | 25 | 42 | | 10 | |
| FSD0193NB | 25*42*10 TC | | 25 | 42 | | 10 | |
| FSD0071NB | 25*42*11.5 KCCY | | 25 | 42 | | 11.5 | |
| FSD0072NB | 25*42*11.5 SC | | 25 | 42 | | 11.5 | |
| FSD0913NB | 26*42*6 SC | | 26 | 42 | | 6 | |
| FSD0207NB | 26*42*7 TC | 60955 | 26 | 42 | | 7 | |
| FSD0638NB | 26*42*7/10 TCU | 91252-230-003 | 26 | 42 | | 7 | 10 |
| FSD0120NB | 26*42*8 HTCR | | 26 | 42 | | 8 | |
| FSD0366QB | 26*42*8 HTCR (VMQ) | | 26 | 42 | | 8 | |
| FSD0070NB | 26*42*8 TC | | 26 | 42 | | 8 | |
| FSD0667NB | 26*42*10 TC | | 26 | 42 | | 10 | |
| FSD0188NB | 27*42*7 TC | 91216-PC8-003-05 | 27 | 42 | | 7 | |
| FSD0863NB | 27*42*8 TC | | 27 | 42 | | 8 | |
| FSD0763NB | 27*42*9 TC | | 27 | 42 | | 9 | |
| FSD0879NB | 27*42*10 SC | | 27 | 42 | | 10 | |
| FSD0914NB | 27*42*10 TC | | 27 | 42 | | 10 | |
| FSD0923NB | 28*42*6 SB | | 28 | 42 | | 6 | |
| FSD0928NB | 28*42*6 TC | | 28 | 42 | | 6 | |
| FSD0601NB | 28*42*6/8.4 KC9 | GCEX0022 | 28 | 42 | | 6 | 8.4 |
| FSD0225QB | 28*42*7 HTCR(VMQ) | | 28 | 42 | | 7 | |
| FSD0694NB | 28*42*7 SC | | 28 | 42 | | 7 | |
| FSD0226NB | 28*42*7 TC | | 28 | 42 | | 7 | |
| FSD0226FB | 28*42*7 TC(VITON) | | 28 | 42 | | 7 | |
| FSD0227NB | 28*42*8 HTCL | 91213-PT0-003 | 28 | 42 | | 8 | |
| FSD0069NB | 28*42*8 TC | 91213-PTO-0003/4 | 28 | 42 | | 8 | |
| FSD0116NB | 28*42*10 TC | | 28 | 42 | | 10 | |
| FSD0235AB | 28.5*42*9 (ACM) | 89015 CA | 28.5 | 42 | | 9 | |
| FSD0238NB | 29*42*6.5 SBP | | 29 | 42 | | 6.5 | |
| FSD0955NB | 29*42*8 TC | | 29 | 42 | | 8 | |
| FSD0068NB | 30*42*4.5 SC | | 30 | 42 | | 4.5 | |
| FSD0906NB | 30*42*5 TC | | 30 | 42 | | 5 | |
| FSD0906FB | 30*42*5 TC(VITON) | | 30 | 42 | | 5 | |

| WLK CODE | OIL SEALS | DESCRIPTION | ID | OD1 | OD2 | H1 | H2 |
|-----------|--------------------------|--------------------------|------|-----|-----|------|------|
| FSD0134NB | 30*42*5.7 SC | | 30 | 42 | | 5.7 | |
| FSD0067NB | 30*42*6 SC | | 30 | 42 | | 6 | |
| FSD0090NB | 30*42*6 TC | | 30 | 42 | | 6 | |
| FSD0090FB | 30*42*6 TC(FKM)VITON | | 30 | 42 | | 6 | |
| FSD0090QB | 30*42*6 TC(VMQ) | | 30 | 42 | | 6 | |
| FSD0539N0 | 30*42*6/9 TDKI | | 30 | 42 | | 6 | 9 |
| FSD0139A0 | 30*42*6.5 VC (ACM) | 006 99 77 347 | 30 | 42 | | 6.5 | |
| FSD0933QB | 30*42*7 HTCR(VMQ) | | 30 | 42 | | 7 | |
| FSD0247NB | 30*42*7 SC | 8個小洞 藍色1;黑色 | 30 | 42 | | 7 | |
| FSD0247FB | 30*42*7 SC (FKM) | | 30 | 42 | | 7 | |
| FSD0247NS | 30*42*7 SC(S304 SPRING) | 8個小洞 | 30 | 42 | | 7 | |
| FSD0093NB | 30*42*7 TC | | 30 | 42 | | 7 | |
| FSD0093FB | 30*42*7 TC (FKM) | | 30 | 42 | | 7 | |
| FSD0934NB | 30*42*8 SB | | 30 | 42 | | 8 | |
| FSD0066NB | 30*42*8 SC | 90043-10020 | 30 | 42 | | 8 | |
| FSD0471NB | 30*42*8 TB(TM) | | 30 | 42 | | 8 | |
| FSD0151NB | 30*42*8 TC | 9-09924-451-0 | 30 | 42 | | 8 | |
| FSD0151FB | 30*42*8 TC(VITON) | | 30 | 42 | | 8 | |
| FSD0249NB | 30*42*10 SC | | 30 | 42 | | 10 | |
| FSD0630NB | 30*42*10 TC | | 30 | 42 | | 10 | |
| FSD0065NB | 30*42*10.5 TC4 | 51153-08030, S0351-32000 | 30 | 42 | | 10.5 | |
| FSD0064NB | 30*42*11 DC4(DC) | RXS, RXZ, 164-23145-01 | 30 | 42 | | 11 | |
| FSD0473N0 | 30.1*42*6 HMF(KZ3) | NBR80 | 30.1 | 42 | | 6 | |
| FSD0063NB | 31*42*8 TC | EY25 | 31 | 42 | | 8 | |
| FSD0855NB | 32*42*4 SC | | 32 | 42 | | 4 | |
| FSD0819NB | 32*42*4 VB | | 32 | 42 | | 4 | |
| FSD0794N0 | 32*42*4 VG | | 32 | 42 | | 4 | |
| FSD0373NB | 32*42*5 KC | | 32 | 42 | | 5 | |
| FSD0466NB | 32*42*5 TC | | 32 | 42 | | 5 | |
| FSD0445N0 | 32*42*6 KZ3 | | 32 | 42 | | 6 | |
| FSD0877NB | 32*42*6 TC | | 32 | 42 | | 6 | |
| FSD0884NB | 32*42*7 TB | | 32 | 42 | | 7 | |
| FSD0155NB | 32*42*7 TC | | 32 | 42 | | 7 | |
| FSD0155NS | 32*42*7 TC (S304 SPRING) | SUS304 SPRING | 32 | 42 | | 7 | |
| FSD0155FB | 32*42*7 TC(VITON)FKM | | 32 | 42 | | 7 | |
| FSD0938NB | 32*42*7/7.7 TCP | | 32 | 42 | | 7 | 7.7 |
| FSD0274NB | 32*42*8 TC | | 32 | 42 | | 8 | |
| FSD0892FB | 32*42*8 TC(VITON) | | 32 | 42 | | 8 | |
| FSD0062NB | 32*42*9 TC | | 32 | 42 | | 9 | |
| FSD0275NB | 32*42*10 TC | | 32 | 42 | | 10 | |
| FSD0212NB | 32*42*10/13 TC4 | | 32 | 42 | | 10 | 13 |
| FSD0925NB | 32*42*10/15 HTC4CL | | 32 | 42 | | 10 | 15 |
| FSD0891NB | 32*42*10/15 TC9 | | 32 | 42 | | 10 | 15 |
| FSD0902NB | 32*42*10/12.5 HTC4YL | 24780-83010 | 32 | 42 | | 10 | 12.5 |
| FSD0666NB | 34*42*4 VG | | 34 | 42 | | 4 | |
| FSD0612NB | 34*42*8 TC | | 34 | 42 | | 8 | |
| FSD0696NB | 35*42*4 SB | | 35 | 42 | | 4 | |
| FSD0635NB | 35*42*4 SC | | 35 | 42 | | 4 | |
| FSD0687NB | 35*42*4 TC | | 35 | 42 | | 4 | |
| FSD0637NB | 35*42*4 TZ | | 35 | 42 | | 4 | |
| FSD0725N0 | 35*42*4 VB | | 35 | 42 | | 4 | |
| FSD0634NB | 35*42*4 VG | | 35 | 42 | | 4 | |
| FSD0860NB | 35*42*5 SB | | 35 | 42 | | 5 | |
| FSD0717NB | 35*42*7 TC | | 35 | 42 | | 7 | |
| FSD0717NS | 35*42*7 TC(S304 SPRING) | | 35 | 42 | | 7 | |
| FSD0618NB | 35*42*8 TC | | 35 | 42 | | 8 | |
| FSD0824NB | 35*42*10 VB | | 35 | 42 | | 10 | |

| WLK CODE | OIL SEALS | DESCRIPTION | ID | OD1 | OD2 | H1 | H2 |
|-----------|---------------------------|--------------------------|-------|-------|-----|------|-----|
| FSD9993NB | 31.75*42.67*7.87 TC | 1.250*1.680*0.310 TC | 31.75 | 42.67 | | 7.87 | |
| FSD0098N0 | 25.5*42.7*8.8 | | 25.5 | 42.7 | | 8.8 | |
| FSD9996NB | 30.75*42.75*9.53 SM | 298423 | 30.75 | 42.75 | | 9.53 | |
| FSD0430NB | 28.83*42.80*6.35 SB(BH2) | 1.135*1.685*0.250 SB(SZ) | 28.83 | 42.8 | | 6.35 | |
| FSD9923NB | 31.75*42.86*6.35 TC | | 31.75 | 42.86 | | 6.35 | |
| FSD9971NB | 31.75*42.86*7.95 TC | | 31.75 | 42.86 | | 7.95 | |
| FSD0905NB | 25.4*42.88*7.95 TB | | 25.4 | 42.88 | | 7.95 | |
| FSD9903NB | 31.75*42.88*9.53 SC | | 31.75 | 42.88 | | 9.53 | |
| FSD0800NB | 25*42.9*9.5 TC | | 25 | 42.9 | | 9.5 | |
| FSD0095Q0 | 27.3*42.9*11 軟(VMQ) | (VMQ) | 27.3 | 42.9 | | 11 | |
| FSD0211NB | 27.05*42.93*7.95 TCW(ACM) | 1.065*1.690*0.313 TCW | 27.05 | 42.93 | | 7.95 | |
| FSD0158N0 | 31.75*42.93*5.46 VC | 1.250*1.690*0.215 VC | 31.75 | 42.93 | | 5.46 | |
| FSD0754NB | 20*43*8 TC | | 20 | 43 | | 8 | |
| FSD0679NB | 23*43*7 TC | | 23 | 43 | | 7 | |
| FSD0167NB | 24*43*6 TC | | 24 | 43 | | 6 | |
| FSD0167FB | 24*43*6 TC(FKM)VITON | | 24 | 43 | | 6 | |
| FSD0497NB | 24*43*7 TA | | 24 | 43 | | 7 | |
| FSD0532NB | 24*43*7 TC | | 24 | 43 | | 7 | |
| FSD0827NB | 24*43*8.5 TZ | | 24 | 43 | | 8.5 | |
| FSD0948NB | 24*43*8.5 TZ2 | AP8916,WLK | 24 | 43 | | 8.5 | |
| FSD0785NB | 24*43*9 TC | | 24 | 43 | | 9 | |
| FSD0828NB | 25*43*6 TC | | 25 | 43 | | 6 | |
| FSD0582NB | 25*43*7 TC | | 25 | 43 | | 7 | |
| FSD0726NB | 25*43*8 TC | | 25 | 43 | | 8 | |
| FSD0912NB | 25*43*9 SC | | 25 | 43 | | 9 | |
| FSD0599NB | 25*43*9 TC | | 25 | 43 | | 9 | |
| FSD0571NB | 25*43*10 HTCR | | 25 | 43 | | 10 | |
| FSD0761NB | 25*43*10 TC | | 25 | 43 | | 10 | |
| FSD0546NB | 26*43*7 TC | | 26 | 43 | | 7 | |
| FSD0791NB | 26*43*8 TC | | 26 | 43 | | 8 | |
| FSD0661NB | 27*43*6 TC Brown | | 27 | 43 | | 6 | |
| FSD0525NB | 27*43*7 TC | | 27 | 43 | | 7 | |
| FSD0525FB | 27*43*7 TC(VITON) | | 27 | 43 | | 7 | |
| FSD0464NB | 27*43*8 TC | | 27 | 43 | | 8 | |
| FSD0523NB | 27*43*9 HTCL | 91203-PG6-003 | 27 | 43 | | 9 | |
| FSD0745NB | 27*43*9 HTCR | 8-94326-441-0 | 27 | 43 | | 9 | |
| FSD0131NB | 27*43*9 TC | 8-94326-441-0 | 27 | 43 | | 9 | |
| FSD0501NB | 28*43*7 TC | | 28 | 43 | | 7 | |
| FSD0501FB | 28*43*7 TC(VITON) | | 28 | 43 | | 7 | |
| FSD0943NB | 28*43*7 TZ | | 28 | 43 | | 7 | |
| FSD0552NB | 28*43*8 TB | | 28 | 43 | | 8 | |
| FSD0061NB | 28*43*8 TC | | 28 | 43 | | 8 | |
| FSD0740NB | 28*43*10 SB | | 28 | 43 | | 10 | |
| FSD0803NB | 28*43*10 SC | | 28 | 43 | | 10 | |
| FSD0393NB | 28*43*10 TC | | 28 | 43 | | 10 | |
| FSD0436NB | 28.6*43*6.5 TB | 90311-28003, Winch Worm | 28.6 | 43 | | 6.5 | |
| FSD0632NB | 29*43*8 HTCL | 91213-PR3-003/4 | 29 | 43 | | 8 | |
| FSD0579NB | 29*43*8 TC | | 29 | 43 | | 8 | |
| FSD0764NB | 30*43*6 TC | | 30 | 43 | | 6 | |
| FSD0689NB | 30*43*7 HTCR | | 30 | 43 | | 7 | |
| FSD0398NB | 30*43*7 TC | | 30 | 43 | | 7 | |
| FSD0520NB | 30*43*8 TC | | 30 | 43 | | 8 | |
| FSD0250NB | 30*43*8/5.5 TCY | | 30 | 43 | | 8 | 5.5 |
| FSD0060NB | 30*43*9 TC | | 30 | 43 | | 9 | |
| FSD0060FB | 30*43*9 TC(VITON) | | 30 | 43 | | 9 | |
| FSD0700NB | 30*43*10 DC | | 30 | 43 | | 10 | |
| FSD0122NB | 30*43*10 TC | | 30 | 43 | | 10 | |

| WLK CODE | OIL SEALS | DESCRIPTION | ID | OD1 | OD2 | H1 | H2 |
|------------|-----------------------------|--------------------------|-------|-------|-----|-------|------|
| FSD0919NB | 31*43*6 TC | | 31 | 43 | | 6 | |
| FSD0744NB | 31*43*8 TC | | 31 | 43 | | 8 | |
| FSD0058NB | 31*43*10.5 DC | | 31 | 43 | | 10.5 | |
| FSD0462NB | 31*43*10.5 DC4 | 91255-331-671 | 31 | 43 | | 10.5 | |
| FSD0057NB | 31*43*10.5 TC4 | 91255-3331 | 31 | 43 | | 10.5 | |
| FSD0056NB | 31*43*12.5 TC4 | 2A623-14500 | 31 | 43 | | 12.5 | |
| FSD0270NB | 31*43*12.5/14.5 TC6(TCU) | | 31 | 43 | | 12.5 | 14.5 |
| FSD0102NB | 31*43*12.7 TC4 | | 31 | 43 | | 12.7 | |
| FSD0908NB | 32*43*5.5 TC | | 32 | 43 | | 5.5 | |
| FSD0480NB | 32*43*7 TC | 48040-84500 | 32 | 43 | | 7 | |
| FSD0647NB | 32*43*7 TCV(NBR80shore) | | 32 | 43 | | 7 | |
| FSD0747NB | 32*43*10.5 DC(NBR75) | | 32 | 43 | | 10.5 | |
| FSD0277NB | 32*43*12.5 TC4 | 51153-48500 | 32 | 43 | | 12.5 | |
| FSD0953NB | 33*43*6 SC | | 33 | 43 | | 6 | |
| FSD0770NB | 33*43*7 SC | | 33 | 43 | | 7 | |
| FSD0887NB | 33*43*7 TC | | 33 | 43 | | 7 | |
| FSD0859NB | 33*43*7 TCV(BROWN)NBR80 | | 33 | 43 | | 7 | |
| FSD0505NB | 33*43*8 TC | | 33 | 43 | | 8 | |
| FSD0783NB | 34*43*7 TC | | 34 | 43 | | 7 | |
| FSD0899NB | 35*43*6 SC | | 35 | 43 | | 6 | |
| FSD0646NB | 35*43*7 HPCR | | 35 | 43 | | 7 | |
| FSD0772NB | 35*43*8 TZ | | 35 | 43 | | 8 | |
| FSD0775NB | 38*43*3 VB | | 38 | 43 | | 3 | |
| FSD0251NB | 30*43.3*10 SC | B/S 9HP | 30 | 43.3 | | 10 | |
| FSD0252NB | 30*43.3*10 TA | | 30 | 43.3 | | 10 | |
| FSD0367NB | 25*43.5*10 TC | 文豐126A履帶式搬運用 | 25 | 43.5 | | 10 | |
| FSD0267NB | 30.1*43.7*12 TC | | 30.1 | 43.7 | | 12 | |
| FSD0055NB | 29*43.75*12.5 TB | | 29 | 43.75 | | 12.5 | |
| FSD0952N0 | 33.58*43.99*10.92 Blue 軟 | 1.322*1.732*0.430 | 33.58 | 43.99 | | 10.92 | |
| FSD0743NB | 20*44*7 TC | | 20 | 44 | | 7 | |
| FSD0639NB | 22*44*7 TC | | 22 | 44 | | 7 | |
| FSD0718NB | 22*44*8 TC | | 22 | 44 | | 8 | |
| FSD0954NB | 22*44*11 TC | | 22 | 44 | | 11 | |
| FSD0053NB | 25*44*7 TC | 09283-25037 TS125ER | 25 | 44 | | 7 | |
| FSD0053FS | 25*44*7 TC(FKM+S304 Spring) | VITON+白鐵彈簧 | 25 | 44 | | 7 | |
| FSD0053NS | 25*44*7 TC(S304SPRING) | | 25 | 44 | | 7 | |
| FSD0498NB | 25*44*8 TC | | 25 | 44 | | 8 | |
| FSD0054NB | 25*44*9 TC | | 25 | 44 | | 9 | |
| FSD0607NB | 25*44*10 TC | | 25 | 44 | | 10 | |
| FSD0870NB | 27*44*7.5/10.5 SCYI | Hyundai Accent PlusSeals | 27 | 44 | | 7.5 | 10.5 |
| FSD0829NB | 28*44*6 TC | | 28 | 44 | | 6 | |
| FSD0052NB | 28*44*7 TC | | 28 | 44 | | 7 | |
| FSD0052FB | 28*44*7 TC(VITON) | | 28 | 44 | | 7 | |
| FSD0578NB | 28*44*9 TC(BROWN) | | 28 | 44 | | 9 | |
| FSD0051NB | 30*44*5 SC | D950 曲軸 | 30 | 44 | | 5 | |
| FSD0253NB | 30*44*7 HPCR | RF01-12-602 | 30 | 44 | | 7 | |
| FSD00253QB | 30*44*7 HPCR(VMQ) | AH1671P | 30 | 44 | | 7 | |
| FSD0050NB | 30*44*7 TC | B630-10-602, RF01-12-602 | 30 | 44 | | 7 | |
| FSD0050FB | 30*44*7 TC(VITON) | | 30 | 44 | | 7 | |
| FSD0540NB | 30*44*8 TC | | 30 | 44 | | 8 | |
| FSD0255NB | 30*44*9 HPCR | | 30 | 44 | | 9 | |
| FSD0254NB | 30*44*9 TC | 0155-16-103 | 30 | 44 | | 9 | |
| FSD0399NB | 30*44*10 TC | | 30 | 44 | | 10 | |
| FSD0271NB | 31*44*6 SC | | 31 | 44 | | 6 | |
| FSD0766NB | 31*44*7 TC | | 31 | 44 | | 7 | |
| FSD0537NB | 32*44*6 HPCR | | 32 | 44 | | 6 | |
| FSD0411NB | 32*44*7 TC | | 32 | 44 | | 7 | |

| WLK CODE | OIL SEALS | DESCRIPTION | ID | OD1 | OD2 | H1 | H2 |
|-----------|------------------------------------|-------------------------|-------|-------|-----|------|-----|
| FSD0137NB | 32*44*8 DC | | 32 | 44 | | 8 | |
| FSD0280NB | 32*44*8 TB | | 32 | 44 | | 8 | |
| FSD0278NB | 32*44*8 TC | | 32 | 44 | | 8 | |
| FSD0279NB | 32*44*8/9.5 TCY | 300/44 NBR 80 | 32 | 44 | | 8 | 9.5 |
| FSD0281NB | 32*44*9 SB(SM) | 90310-32040/10/14/24 | 32 | 44 | | 9 | |
| FSD0282NB | 32*44*9 TB | | 32 | 44 | | 9 | |
| FSD0927NB | 32*44*9 TC | | 32 | 44 | | 9 | |
| FSD0412NB | 32*44*10 TC | | 32 | 44 | | 10 | |
| FSD0283NB | 32*44*10.5 DC4 | | 32 | 44 | | 10.5 | |
| FSD0049NB | 32*44*10.5 TC4 | | 32 | 44 | | 10.5 | |
| FSD0292NB | 33*44*8 TB(TZ) | 90311-33085 | 33 | 44 | | 8 | |
| FSD0790NB | 33*44*8 TC | | 33 | 44 | | 8 | |
| FSD0293NB | 33*44*9 TB | | 33 | 44 | | 9 | |
| FSD0489NB | 33*44*9 TC | | 33 | 44 | | 9 | |
| FSD0771NB | 34*44*6 SC | | 34 | 44 | | 6 | |
| FSD0796NB | 34*44*7 TC | | 34 | 44 | | 7 | |
| FSD0544NB | 34*44*8 TC | 90043-11168-000 | 34 | 44 | | 8 | |
| FSD0797NB | 34*44*8 TZ | | 34 | 44 | | 8 | |
| FSD0472NB | 34*44*10 TB | | 34 | 44 | | 10 | |
| FSD0581NB | 35*44*7 TB3 | 90311-35038 | 35 | 44 | | 7 | |
| FSD0917NB | 35*44*7 TC | | 35 | 44 | | 7 | |
| FSD0530NB | 36*44*5 TC | 90311-36005 | 36 | 44 | | 5 | |
| FSD0320NB | 38*44/47*18 SC5 | 90310-38033,90311-38033 | 38 | 44 | 47 | 18 | |
| FSD9928NB | 19.05*44.45*6.35 TC | | 19.05 | 44.45 | | 6.35 | |
| FSD9981NB | 19.05*44.45*7.93 SC | | 19.05 | 44.45 | | 7.93 | |
| FSD9999NB | 25.4*44.45*4.78 SB | 1.000*1.750*0.188 SB | 25.4 | 44.45 | | 4.78 | |
| FSD9920NB | 25.4*44.45*6.35 TBP Green Painting | #9998 NBR80 | 25.4 | 44.45 | | 6.35 | |
| FSD9977NB | 25.4*44.45*6.35 TC | 1.000*1.750*0.250 TC | 25.4 | 44.45 | | 6.35 | |
| FSD9976NB | 25.4*44.45*6.35 VB | | 25.4 | 44.45 | | 6.35 | |
| FSD0390NB | 25.4*44.45*6.4 TC | | 25.4 | 44.45 | | 6.4 | |
| FSD9949NB | 25.4*44.45*7.92 TM | | 25.4 | 44.45 | | 7.92 | |
| FSD9894NB | 25.4*44.45*7.95 TC | | 25.4 | 44.45 | | 7.95 | |
| FSD0512NB | 25.4*44.45*9.5 TC | | 25.4 | 44.45 | | 9.5 | |
| FSD9955NB | 25.4*44.45*9.52 TB | | 25.4 | 44.45 | | 9.52 | |
| FSD9961NB | 25.4*44.45*9.52 TC | 1.000*1.750*0.375 | 25.4 | 44.45 | | 9.52 | |
| FSD9975NB | 27*44.45*9.53 TC | | 27 | 44.45 | | 9.53 | |
| FSD9974NB | 28.58*44.45*6.35 TC | 1.125*1.750*0.250 TC | 28.58 | 44.45 | | 6.35 | |
| FSD9904FB | 30.18*44.45*6.35 SC(FKM) | VITON | 30.18 | 44.45 | | 6.35 | |
| FSD9901NB | 30.96*44.45*7.95 TB | | 30.96 | 44.45 | | 7.95 | |
| FSD9991NB | 31.75*44.45*6.35 SB | 1.250*1.750*0.250 SB | 31.75 | 44.45 | | 6.35 | |
| FSD0511NB | 31.75*44.45*6.35 SC | 1.250*1.750*0.250 SC | 31.75 | 44.45 | | 6.35 | |
| FSD9957NB | 31.75*44.45*6.35 TB | 1.250*1.750*0.250 TB | 31.75 | 44.45 | | 6.35 | |
| FSD9990NB | 31.75*44.45*6.35 TC | 1.250*1.750*0.250 TC | 31.75 | 44.45 | | 6.35 | |
| FSD9937NB | 31.75*44.45*6.35/6.8 TCV | | 31.75 | 44.45 | | 6.35 | 6.8 |
| FSD9970NB | 31.75*44.45*7.93 TC | | 31.75 | 44.45 | | 7.93 | |
| FSD0092NB | 31.75*44.45*8 TB | 1.250*1.750*0.315 TB | 31.75 | 44.45 | | 8 | |
| FSD0457NB | 31.75*44.45*9.53 TC | | 31.75 | 44.45 | | 9.53 | |
| FSD9916NB | 31.75*44.45*9.53 TZ | | 31.75 | 44.45 | | 9.53 | |
| FSD9910NB | 31.75*44.45*9.9 TCV | 1.250*1.750*0.390 TCV | 31.75 | 44.45 | | 9.9 | |
| FSD9932N0 | 34.92*44.45*4.78 VC | | 34.92 | 44.45 | | 4.78 | |
| FSD9932F0 | 34.92*44.45*4.78 VC(FKM) | VITON | 34.92 | 44.45 | | 4.78 | |
| FSD9926NB | 34.92*44.45*6.35 TC | | 34.92 | 44.45 | | 6.35 | |
| FSD9984NB | 19.05*44.5*7.92 SC | | 19.05 | 44.5 | | 7.92 | |
| FSD0162NB | 19.05*44.5*7.92 TB | 0.750*1.752*0.312 TB | 19.05 | 44.5 | | 7.92 | |
| FSD0510NB | 25.4*44.5*4.8 TC | | 25.4 | 44.5 | | 4.8 | |
| FSD9954NB | 25.4*44.5*6.35 TB | | 25.4 | 44.5 | | 6.35 | |
| FSD0243NB | 31.34*44.50*6.35 SC | 1.234*1.752*0.250 SC | 31.34 | 44.5 | | 6.35 | |

| WLK CODE | OIL SEALS | DESCRIPTION | ID | OD1 | OD2 | H1 | H2 |
|-----------|------------------------|----------------------|-------|------|-----|------|----|
| FSD9963NB | 31.75*44.5*6.35 SB | | 31.75 | 44.5 | | 6.35 | |
| FSD0626NB | 32*44.5*12 TC4 NBR80 | | 32 | 44.5 | | 12 | |
| FSD0242NB | 31*44.6*6 SC | 1.250*1.750*0.250 SC | 31 | 44.6 | | 6 | |
| FSD0751NB | 17*45*7 TC | | 17 | 45 | | 7 | |
| FSD0753NB | 18*45*8 TC | | 18 | 45 | | 8 | |
| FSD0376NB | 20*45*7 TC | | 20 | 45 | | 7 | |
| FSD0059NB | 20*45*8 TC | K75 油封 | 20 | 45 | | 8 | |
| FSD0453NB | 20*45*10 TC(BROWN) | | 20 | 45 | | 10 | |
| FSD0932NB | 21*45*7 TC | | 21 | 45 | | 7 | |
| FSD0931NB | 21*45*10 TC | | 21 | 45 | | 10 | |
| FSD0478NB | 22*45*7 TC | | 22 | 45 | | 7 | |
| FSD0381NB | 22*45*8 TC | | 22 | 45 | | 8 | |
| FSD0381FB | 22*45*8 TC(VITON) | | 22 | 45 | | 8 | |
| FSD0576NB | 22*45*9 TC | 03AT36 | 22 | 45 | | 9 | |
| FSD0653NB | 22*45*10 TC | | 22 | 45 | | 10 | |
| FSD0756NB | 23*45*8 TC | | 23 | 45 | | 8 | |
| FSD0479NB | 24*45*6 TC | | 24 | 45 | | 6 | |
| FSD0477NB | 24*45*7 TC | | 24 | 45 | | 7 | |
| FSD0617NB | 24*45*8 TC | | 24 | 45 | | 8 | |
| FSD0048NB | 25*45*5 SC | | 25 | 45 | | 5 | |
| FSD0047NB | 25*45*7 SC | K75 油封 | 25 | 45 | | 7 | |
| FSD0117NB | 25*45*7 TC | | 25 | 45 | | 7 | |
| FSD0117FB | 25*45*7 TC(VITON) | | 25 | 45 | | 7 | |
| FSD0470NB | 25*45*8 TB | | 25 | 45 | | 8 | |
| FSD0195NB | 25*45*8 TC | | 25 | 45 | | 8 | |
| FSD0195NS | 25*45*8 TC(S304SPIRNG) | | 25 | 45 | | 8 | |
| FSD0822NB | 25*45*9 TC | | 25 | 45 | | 9 | |
| FSD0197NB | 25*45*10 TB | Compressor ISUZU JCR | 25 | 45 | | 10 | |
| FSD0046NB | 25*45*10 TC | | 25 | 45 | | 10 | |
| FSD0046FB | 25*45*10 TC (FKM)VITON | | 25 | 45 | | 10 | |
| FSD0148NB | 25*45*11 TC | 90311-25002 | 25 | 45 | | 11 | |
| FSD0594NB | 25*45*12.5 TCN | | 25 | 45 | | 12.5 | |
| FSD0762NB | 26*45*7 TC | | 26 | 45 | | 7 | |
| FSD0643NB | 27*45*6 TC | | 27 | 45 | | 6 | |
| FSD0499NB | 27*45*7 TC | | 27 | 45 | | 7 | |
| FSD0119NB | 27*45*8 TC | | 27 | 45 | | 8 | |
| FSD0524NB | 27*45*9 TC | | 27 | 45 | | 9 | |
| FSD0231NB | 28*45*6 SC | TS130 起動STARTING | 28 | 45 | | 6 | |
| FSD0045NB | 28*45*6 TC | | 28 | 45 | | 6 | |
| FSD0692NB | 28*45*7.5 TC | | 28 | 45 | | 7.5 | |
| FSD0150NB | 28*45*8 TC | | 28 | 45 | | 8 | |
| FSD0150FB | 28*45*8 TC(VITON) | | 28 | 45 | | 8 | |
| FSD0394NB | 28*45*10 TC | | 28 | 45 | | 10 | |
| FSD0394FB | 28*45*10 TC(VITON) | | 28 | 45 | | 10 | |
| FSD0434NB | 29*45*8 HTCL | 91213-PCG-003 | 29 | 45 | | 8 | |
| FSD0434QB | 29*45*8 HTCL(VMQ) | | 29 | 45 | | 8 | |
| FSD0691NB | 29*45*8 TC | | 29 | 45 | | 8 | |
| FSD0597NB | 29*45*9 TC | | 29 | 45 | | 9 | |
| FSD0916NB | 30*45*5 SC | | 30 | 45 | | 5 | |
| FSD0456NB | 30*45*6 HTMR | MD-703735 | 30 | 45 | | 6 | |
| FSD0256NB | 30*45*6 SC | | 30 | 45 | | 6 | |
| FSD0439NB | 30*45*6 TC | 43143-44000;MD031837 | 30 | 45 | | 6 | |
| FSD0439FB | 30*45*6 TC(VITON) | | 30 | 45 | | 6 | |
| FSD0127NB | 30*45*7 HSBR | | 30 | 45 | | 7 | |
| FSD0893FB | 30*45*7 SC(VITON) | TC修掉副唇 | 30 | 45 | | 7 | |
| FSD0129NB | 30*45*7 TB | | 30 | 45 | | 7 | |
| FSD0400NB | 30*45*7 TC | | 30 | 45 | | 7 | |

| WLK CODE | OIL SEALS | DESCRIPTION | ID | OD1 | OD2 | H1 | H2 |
|-----------|-------------------------|--------------------------|------|-------|-----|------|-----|
| FSD0400FB | 30*45*7 TC(VITON) | | 30 | 45 | | 7 | |
| FSD0660NB | 30*45*8 HTCR | 90311-30014 | 30 | 45 | | 8 | |
| FSD0044NB | 30*45*8 TB | EY25 | 30 | 45 | | 8 | |
| FSD0043NB | 30*45*8 TC | 90311-30115, YZC油封 | 30 | 45 | | 8 | |
| FSD0043FB | 30*45*8 TC(VITON) | | 30 | 45 | | 8 | |
| FSD0043QB | 30*45*8 TC(VMQ) | | 30 | 45 | | 8 | |
| FSD0213NB | 30*45*8/30 Y | | 30 | 45 | | 8 | 30 |
| FSD0214NB | 30*45*8/8.5 TCV(NBR80) | | 30 | 45 | | 8 | 8.5 |
| FSD0650NB | 30*45*10 TB | | 30 | 45 | | 10 | |
| FSD0401NB | 30*45*10 TC | | 30 | 45 | | 10 | |
| FSD0583NB | 30*45*11 TC | | 30 | 45 | | 11 | |
| FSD0652NB | 30*45*12 DC | | 30 | 45 | | 12 | |
| FSD0567NB | 30*45*13 TC | | 30 | 45 | | 13 | |
| FSF0506NB | 30*45/62*15/41 Y | 32136-G1001 | 30 | 45 | 62 | 15 | 41 |
| FSG0383NB | 30*45/77*45 Y | 32136-H5000 | 30 | 45 | 77 | 45 | |
| FSD0217NB | 31*45*7 HTCR(BROWN) | MD-115245 | 31 | 45 | | 7 | |
| FSD0602NB | 31*45*7 TC | | 31 | 45 | | 7 | |
| FSD0767NB | 31*45*8 TC | | 31 | 45 | | 8 | |
| FSD0701NB | 32*45*4 VB | | 32 | 45 | | 4 | |
| FSD0930N0 | 32*45*4 VC | | 32 | 45 | | 4 | |
| FSD0042NB | 32*45*5 SC | | 32 | 45 | | 5 | |
| FSD0041NB | 32*45*6 SC | TS155 起動STARTING | 32 | 45 | | 6 | |
| FSD0040NB | 32*45*6 TC | TS230 起動 | 32 | 45 | | 6 | |
| FSD0419NB | 32*45*7 SC | | 32 | 45 | | 7 | |
| FSD0419NS | 32*45*7 SC (S304SPRING) | | 32 | 45 | | 7 | |
| FSD0039NB | 32*45*7 TB | HD125 | 32 | 45 | | 7 | |
| FSD0414NB | 32*45*7 TC | | 32 | 45 | | 7 | |
| FSD0414FB | 32*45*7 TC(VITON) | | 32 | 45 | | 7 | |
| FSD0806NB | 32*45*8 TB | | 32 | 45 | | 8 | |
| FSD0038NB | 32*45*8 TC | 32219-Z5000;MH-034057/67 | 32 | 45 | | 8 | |
| FSD0415NB | 32*45*10 TC | | 32 | 45 | | 10 | |
| FSD0795NB | 33*45*7 SC | | 33 | 45 | | 7 | |
| FSD0138NB | 33*45*8 TC | | 33 | 45 | | 8 | |
| FSD0939NB | 33*45*11 TC4 | | 33 | 45 | | 11 | |
| FSD0888NB | 34*45*6 SC | | 34 | 45 | | 6 | |
| FSD0037NB | 34*45*6 TC | | 34 | 45 | | 6 | |
| FSD0730NB | 34*45*7 TC | | 34 | 45 | | 7 | |
| FSD0713NB | 34*45*8 TC | | 34 | 45 | | 8 | |
| FSD0801NB | 35*45*4 TC | | 35 | 45 | | 4 | |
| FSD0171N0 | 35*45*4 VB | | 35 | 45 | | 4 | |
| FSD0465NB | 35*45*5 TC | | 35 | 45 | | 5 | |
| FSD0175NB | 35*45*5/7 OSI NBR | | 35 | 45 | | 5 | 7 |
| FSD0698NB | 35*45*5/8 GA | | 35 | 45 | | 5 | 8 |
| FSD0875NB | 35*45*6 TC | | 35 | 45 | | 6 | |
| FSD0522NB | 35*45*7 SC | | 35 | 45 | | 7 | |
| FSD0522FB | 35*45*7 SC(VITON) | TC修掉副唇 | 35 | 45 | | 7 | |
| FSD0595NB | 35*45*7 TB | | 35 | 45 | | 7 | |
| FSD0302NB | 35*45*7 TC | | 35 | 45 | | 7 | |
| FSD0302FB | 35*45*7 TC(VITON) | | 35 | 45 | | 7 | |
| FSD0440NB | 35*45*8 TC | | 35 | 45 | | 8 | |
| FSD0735NB | 35*45*9 TB | | 35 | 45 | | 9 | |
| FSD0405NB | 35*45*10 TC | | 35 | 45 | | 10 | |
| FSD0405FB | 35*45*10 TC(VITON) | | 35 | 45 | | 10 | |
| FSD0644NB | 37*45*9 TC | 8067-27040 | 37 | 45 | | 9 | |
| FSD0686NB | 38*45*8 KB | | 38 | 45 | | 8 | |
| FSD0776NB | 38*45*8 TC | | 38 | 45 | | 8 | |
| FSD0206NB | 25.4*45.21*6.35 HM21 | 1.000*1.781*0.250 HM21 | 25.4 | 45.21 | | 6.35 | |

| WLK CODE | OIL SEALS | DESCRIPTION | ID | OD1 | OD2 | H1 | H2 |
|-----------|------------------------|-----------------------|-------|-------|-------|-------|------|
| FSD9935NB | 25.81*45.24*10.72 SCYI | 27*45*10.72 SCY | 25.81 | 45.24 | | 10.72 | |
| FSD9987NB | 28.58*45.24*11.90 TB | 1.125*1.781*0.469 TB | 28.58 | 45.24 | | 11.9 | |
| FSD0125N0 | 25.4*45.34*12.07 VB | 1.000*1.785*0.475 VB | 25.4 | 45.34 | | 12.07 | |
| FSD0755NB | 20*46*8 TC | | 20 | 46 | | 8 | |
| FSD0758NB | 24*46*7 TC | | 24 | 46 | | 7 | |
| FSD0711NB | 24*46*10 TC | | 24 | 46 | | 10 | |
| FSD0036NB | 25*46*7 TC | 113LG48 | 25 | 46 | | 7 | |
| FSD0565NB | 27*46*13 SCAJY(Y) | Power Steering used | 27 | 46 | | 13 | |
| FSD0910NB | 28*46*8.5 SCT | | 28 | 46 | | 8.5 | |
| FSD0573NB | 28*46*10 SC | | 28 | 46 | | 10 | |
| FSD0781NB | 28*46*10 TC | | 28 | 46 | | 10 | |
| FSD0561NB | 28*46*12 TC | | 28 | 46 | | 12 | |
| FSD0548NB | 29*46*10 TC | | 29 | 46 | | 10 | |
| FSD0627NB | 30*46*7 HTCR | 21421-21010 | 30 | 46 | | 7 | |
| FSD0035NB | 30*46*7 TC | G300/G400 | 30 | 46 | | 7 | |
| FSD0035FB | 30*46*7 TC(VITON) | | 30 | 46 | | 7 | |
| FSD0258NB | 30*46*8 HTCL | | 30 | 46 | | 8 | |
| FSD0257NB | 30*46*8 HTCR | 8067-30021 | 30 | 46 | | 8 | |
| FSD0132NB | 30*46*8 TC | HONDA G400 | 30 | 46 | | 8 | |
| FSD0956NB | 30*46*10 TC | | 30 | 46 | | 10 | |
| FSD0857NB | 30*46*11 DC | | 30 | 46 | | 11 | |
| FSD0616NS | 30*46*15/25 TCY | S304 SPRING | 30 | 46 | | 15 | 25 |
| FSD0641NB | 31*46*6 TC Brown | | 31 | 46 | | 6 | |
| FSD0433NB | 31*46*8 HTCL | 91212-FED-003 | 31 | 46 | | 8 | |
| FSD0286NB | 32*46*6 HTCR | 90311-32018/01 | 32 | 46 | | 6 | |
| FSD0286QB | 32*46*6 HTCR(VMQ) | | 32 | 46 | | 6 | |
| FSD0556NB | 32*46*7 TC | | 32 | 46 | | 7 | |
| FSD0034NB | 32*46*8 TC | 90311-32023 | 32 | 46 | | 8 | |
| FSD0034FB | 32*46*8 TC(VITON) | | 32 | 46 | | 8 | |
| FSD0033NB | 32*46*11 DC4 | | 32 | 46 | | 11 | |
| FSD0890NB | 32.5*46*6 HTCR | 90311-32001 | 32.5 | 46 | | 6 | |
| FSD0564NB | 32.5*46*6 TC | 90311-32001 | 32.5 | 46 | | 6 | |
| FSD0782NB | 33*46*8 HTZR | | 33 | 46 | | 8 | |
| FSD0031NB | 33*46*10.5 TC4 | 36901-32000 | 33 | 46 | | 10.5 | |
| FSD0716NB | 33*46*11 DC | | 33 | 46 | | 11 | |
| FSD0736NB | 34*46*6 HTCR | | 34 | 46 | | 6 | |
| FSD0623NB | 34*46*6 TC(BROWN) | | 34 | 46 | | 6 | |
| FSD0789NB | 34*46*7 TC | | 34 | 46 | | 7 | |
| FSD0507NB | 34*46*8 TC | 90310-34003 | 34 | 46 | | 8 | |
| FSD0032NB | 35*46*7 TC | IDVA | 35 | 46 | | 7 | |
| FSD0032FB | 35*46*7 TC(VITON) | | 35 | 46 | | 7 | |
| FSD0668NB | 36*46*6 TC | | 36 | 46 | | 6 | |
| FSD0608NB | 36*46*7 TC | | 36 | 46 | | 7 | |
| FSD0317NB | 36*46*9 TC | 90311-36004 | 36 | 46 | | 9 | |
| FSD0454NB | 38*46/52.15*6.5/14.6 Y | BRR897 | 38 | 46 | 52.15 | 6.5 | 14.6 |
| FSD0543NB | 40*46*18 SC5Y | 90310-40001 | 40 | 46 | | 18 | |
| FSD9931NB | 25.4*46.43*11.13 SC | | 25.4 | 46.43 | | 11.13 | |
| FSD9973NB | 28.58*46.43*9.53 TB | | 28.58 | 46.43 | | 9.53 | |
| FSD9930NB | 33.35*46.43*9.53 SC | | 33.35 | 46.43 | | 9.53 | |
| FSD0145N0 | 28.58*46.48*6.35 VBP | 1.125*1.830*0.250 VBP | 28.58 | 46.48 | | 6.35 | |
| FSD0236NB | 28.8*46.6*11 TC | | 28.8 | 46.6 | | 11 | |
| FSD0375NB | 17*47*7 TC | | 17 | 47 | | 7 | |
| FSD0154NB | 17*47*8 TC | | 17 | 47 | | 8 | |
| FSD0496NB | 17*47*10 TC | | 17 | 47 | | 10 | |
| FSD0496FB | 17*47*10 TC(VITON) | | 17 | 47 | | 10 | |
| FSD0147NB | 18*47*10 TC | | 18 | 47 | | 10 | |
| FSD0160NB | 19*47*7 TC | | 19 | 47 | | 7 | |

| WLK CODE | OIL SEALS | DESCRIPTION | ID | OD1 | OD2 | H1 | H2 |
|-----------|----------------------------------|-------------------------|----|-----|-----|------|------|
| FSD0678NB | 19*47*14 DC | | 19 | 47 | | 14 | |
| FSD0799NB | 20*47*5 TC | | 20 | 47 | | 5 | |
| FSD0168NB | 20*47*7 SC | | 20 | 47 | | 7 | |
| FSD0168FB | 20*47*7 SC(VITON) | | 20 | 47 | | 7 | |
| FSD0030NB | 20*47*7 TC | 09500-20477 | 20 | 47 | | 7 | |
| FSD0030FB | 20*47*7 TC (FKM)VITON | | 20 | 47 | | 7 | |
| FSD0030QB | 20*47*7 TC(VMQ) | | 20 | 47 | | 7 | |
| FSD0377NB | 20*47*8 TC | | 20 | 47 | | 8 | |
| FSD0136NB | 20*47*8.5 TC | 09283-20028 | 20 | 47 | | 8.5 | |
| FSD0926NB | 20*47*9 TC | | 20 | 47 | | 9 | |
| FSD0663QB | 20*47*10 SC(VMQ) | | 20 | 47 | | 10 | |
| FSD0029NB | 20*47*10 TC | | 20 | 47 | | 10 | |
| FSD0029FB | 20*47*10 TC(VITON) | | 20 | 47 | | 10 | |
| FSD0423N0 | 20*47*10/12 KC | | 20 | 47 | | 10 | 12 |
| FSD0028NB | 20*47*12 TC3 | | 20 | 47 | | 12 | |
| FSD0488NB | 22*47*7 SC | | 22 | 47 | | 7 | |
| FSD0181NB | 22*47*7 TC | | 22 | 47 | | 7 | |
| FSD0181FB | 22*47*7 TC (FKM)VITON | | 22 | 47 | | 7 | |
| FSD0027NB | 22*47*10 TC | | 22 | 47 | | 10 | |
| FSD0757NB | 23*47*8 TC | | 23 | 47 | | 8 | |
| FSD0184NB | 23*47*10 SC | | 23 | 47 | | 10 | |
| FSD0183NB | 23*47*10 TC | 113LG68 | 23 | 47 | | 10 | |
| FSD0483NB | 24*47*7 SC | | 24 | 47 | | 7 | |
| FSD0153NB | 24*47*7 TC | | 24 | 47 | | 7 | |
| FSD0901NB | 24*47*8 TC | | 24 | 47 | | 8 | |
| FSD0421NB | 24*47*10 TC | | 24 | 47 | | 10 | |
| FSD0026NB | 25*47*5 TC | | 25 | 47 | | 5 | |
| FSD0025NB | 25*47*6 TC | | 25 | 47 | | 6 | |
| FSD0025FB | 25*47*6 TC (FKM)VITON | | 25 | 47 | | 6 | |
| FSD0111N0 | 25*47*7 KC4 | | 25 | 47 | | 7 | |
| FSD0903FB | 25*47*7 SC(VITON) | TC修掉副唇 | 25 | 47 | | 7 | |
| FSD0024NB | 25*47*7 TC | Universal | 25 | 47 | | 7 | |
| FSD0024FB | 25*47*7 TC(VITON) | | 25 | 47 | | 7 | |
| FSD0631NB | 25*47*7 TCV Blue (NBR80) | BABSL0.5 | 25 | 47 | | 7 | |
| FSD0575NS | 25*47/64*7/10.5 TG5Y(S30) | Ariston Merloni Indesit | 25 | 47 | 64 | 7 | 10.5 |
| FSD0023NB | 25*47*8 DC | | 25 | 47 | | 8 | |
| FSD0198NB | 25*47*8 TC | | 25 | 47 | | 8 | |
| FSD0198FB | 25*47*8 TC (FKM)VITON | | 25 | 47 | | 8 | |
| FSD0185NB | 25*47*8.5 TC | | 25 | 47 | | 8.5 | |
| FSD0199NB | 25*47*8.7 TC | 113LG69 | 25 | 47 | | 8.7 | |
| FSD0021NB | 25*47*10 DC | | 25 | 47 | | 10 | |
| FSD0101NB | 25*47*10 DC (Special) | | 25 | 47 | | 10 | |
| FSD0569NS | 25*47*10 DC Washing Machine used | 113ID00 | 25 | 47 | | 10 | |
| FSD0200NB | 25*47*10 SA | | 25 | 47 | | 10 | |
| FSD0386NB | 25*47*10 TC | MACHINE | 25 | 47 | | 10 | |
| FSD0022NB | 25*47*10 TC6(TCU) | | 25 | 47 | | 10 | |
| FSD0022FB | 25*47*10 TC6(TCU)(VITON) | VITON(FKM) | 25 | 47 | | 10 | |
| FSD0022QB | 25*47*10 TC6(VMQ) | | 25 | 47 | | 10 | |
| FSD0202NB | 25*47*10/12 TCA(Y) | 113CY00 | 25 | 47 | | 10 | 12 |
| FSD0591NB | 25*47/54*12.5 TGY(TG5Y) | 03AT46 | 25 | 47 | 54 | 12.5 | |
| FSD0020NB | 25*47/54*13 TC6Y(TCU5) | | 25 | 47 | 54 | 13 | |
| FSD0816NB | 26*47*6 TC | | 26 | 47 | | 6 | |
| FSD0690NB | 26*47*7 SC | | 26 | 47 | | 7 | |
| FSD0699NB | 26*47*7 TC | | 26 | 47 | | 7 | |
| FSD0813NB | 26*47*8 TC | | 26 | 47 | | 8 | |
| FSD0019NB | 26*47*9 TCY | | 26 | 47 | | 9 | |
| FSD0208NB | 26*47*10 SC | | 26 | 47 | | 10 | |

| WLK CODE | OIL SEALS | DESCRIPTION | ID | OD1 | OD2 | H1 | H2 |
|-----------|-------------------------------|----------------------|-------|-----|-----|------|-----|
| FSD0547NB | 26*47*10 TC | | 26 | 47 | | 10 | |
| FSD0852NB | 27*47*5 SC | | 27 | 47 | | 5 | |
| FSD0018NB | 27*47*6 SC | 130536, 03100308 | 27 | 47 | | 6 | |
| FSD0572NB | 27*47*7 SB | | 27 | 47 | | 7 | |
| FSD0392NB | 27*47*7 TC | 113LG82 | 27 | 47 | | 7 | |
| FSD0500NB | 27*47*8 TC | | 27 | 47 | | 8 | |
| FSD0665NB | 27*47*9 TC | | 27 | 47 | | 9 | |
| FSD0450NB | 27*47*10 TC | 113SL00 | 27 | 47 | | 10 | |
| FSD0232NB | 28*47*7 TC | 09283-28022 | 28 | 47 | | 7 | |
| FSD0232FB | 28*47*7 TC(VITON) | | 28 | 47 | | 7 | |
| FSD0017NB | 28*47*8 DC | 93103-28012 DX100 | 28 | 47 | | 8 | |
| FSD0880NB | 28*47*8 HSBR | | 28 | 47 | | 8 | |
| FSD0233NB | 28*47*8 TC | | 28 | 47 | | 8 | |
| FSD0233FB | 28*47*8 TC(VMQ) | | 28 | 47 | | 8 | |
| FSD0121NB | 28*47*10 HTC4R | 09283-28010/19 | 28 | 47 | | 10 | |
| FSD0234NB | 28*47*10 TC | | 28 | 47 | | 10 | |
| FSD0742NB | 29*47*8 TC | | 29 | 47 | | 8 | |
| FSD0915NB | 29*47*10 SC | | 29 | 47 | | 10 | |
| FSD0503NB | 29*47*10 TC | | 29 | 47 | | 10 | |
| FSD0633NB | 29.85*47*11.3 TCAT(Y) | | 29.85 | 47 | | 11.3 | |
| FSD0812NB | 30*47*5 TC | | 30 | 47 | | 5 | |
| FSD0259NB | 30*47*6 HSCL | | 30 | 47 | | 6 | |
| FSD0016NB | 30*47*6 SC | | 30 | 47 | | 6 | |
| FSD0642NB | 30*47*6 TC | | 30 | 47 | | 6 | |
| FSD0683AB | 30*47*7 HTGL(ACM)Brown+ Black | 11242咖啡/黑色雙色 | 30 | 47 | | 7 | |
| FSD0260NB | 30*47*7 SC | 113LG17 | 30 | 47 | | 7 | |
| FSD0260FU | 30*47*7 SC (FKM)S316 | SUS316 SPRING | 30 | 47 | | 7 | |
| FSD0123NB | 30*47*7 TC | | 30 | 47 | | 7 | |
| FSD0123FU | 30*47*7 TC (FKM)S316 | SUS316 SPRING | 30 | 47 | | 7 | |
| FSD0123QB | 30*47*7 TC(VMQ) | | 30 | 47 | | 7 | |
| FSD0935NB | 30*47*7/7.5 TCV | | 30 | 47 | | 7 | 7.5 |
| FSD0015NB | 30*47*8 TC | | 30 | 47 | | 8 | |
| FSD0015FB | 30*47*8 TC(VITON) | | 30 | 47 | | 8 | |
| FSD0936NB | 30*47*8/8.5 TCV | | 30 | 47 | | 8 | 8.5 |
| FSD0262NB | 30*47*9 HTC(TG) | | 30 | 47 | | 9 | |
| FSD0097N0 | 30*47*10 KC | | 30 | 47 | | 10 | |
| FSD0149NB | 30*47*10 KC3Y | | 30 | 47 | | 10 | |
| FSD0263NB | 30*47*10 SA | | 30 | 47 | | 10 | |
| FSD0156NB | 30*47*10 TC | 113LG132 | 30 | 47 | | 10 | |
| FSD0156FB | 30*47*10 TC(VITON) | | 30 | 47 | | 10 | |
| FSD0613NB | 31*47*7 TC | | 31 | 47 | | 7 | |
| FSD9992NB | 31*47*8 HTCR | | 31 | 47 | | 8 | |
| FSD0655NB | 31*47*10 TC | | 31 | 47 | | 10 | |
| FSD0468NB | 32*47*6 HTCR | 09283-32026/36,NJ377 | 32 | 47 | | 6 | |
| FSD0468QB | 32*47*6 HTCR(VMQ) | | 32 | 47 | | 6 | |
| FSD0341NB | 32*47*6 TC | K-301 | 32 | 47 | | 6 | |
| FSD0904FB | 32*47*7 SC(VITON) | TC修掉副唇 | 32 | 47 | | 7 | |
| FSD0288NB | 32*47*7 TB | | 32 | 47 | | 7 | |
| FSD0135NB | 32*47*7 TC | | 32 | 47 | | 7 | |
| FSD0135FB | 32*47*7 TC(VITON) | | 32 | 47 | | 7 | |
| FSD0467NB | 32*47*8 HTCR | 09283-32022/5 | 32 | 47 | | 8 | |
| FSD0416NB | 32*47*8 TC | 09283-32016/22/25 | 32 | 47 | | 8 | |
| FSD0290QB | 32*47*10 HTGW(VMQ) | | 32 | 47 | | 10 | |
| FSD0289NB | 32*47*10 TC | | 32 | 47 | | 10 | |
| FSD0289FB | 32*47*10 TC(VITON) | | 32 | 47 | | 10 | |
| FSD0289QB | 32*47*10 TC(VMQ) | | 32 | 47 | | 10 | |
| FSD0294NB | 33*47*7 TC | | 33 | 47 | | 7 | |

| WLK CODE | OIL SEALS | DESCRIPTION | ID | OD1 | OD2 | H1 | H2 |
|-----------|--------------------------|-------------------------|----|------|-----|-----|----|
| FSD0435NB | 33*47*8 HTCR | 13510-16A00;13510-D0100 | 33 | 47 | | 8 | |
| FSD0435QB | 33*47*8 HTCR (VMQ) | | 33 | 47 | | 8 | |
| FSD0435AB | 33*47*8 HTCR(ACM) | | 33 | 47 | | 8 | |
| FSD0372NB | 33*47*8 TC | | 33 | 47 | | 8 | |
| FSD0628NB | 33*47*10 TC | | 33 | 47 | | 10 | |
| FSD0606NB | 34*47*7 TC | | 34 | 47 | | 7 | |
| FSD0871NB | 34*47*8 TC | | 34 | 47 | | 8 | |
| FSD0651NB | 34*47*9 TC | | 34 | 47 | | 9 | |
| FSD0720NB | 34*47*10 TC | | 34 | 47 | | 10 | |
| FSD0909NB | 35*47*4.5 SC | | 35 | 47 | | 4.5 | |
| FSD0014NB | 35*47*5 SC | | 35 | 47 | | 5 | |
| FSD0014FB | 35*47*5 SC(VITON)FKM | | 35 | 47 | | 5 | |
| FSD0094N0 | 35*47*5 VB(VZ) | 2T C.W. PUMP | 35 | 47 | | 5 | |
| FSD0682FB | 35*47*5.6 HTCR(FKM)VITON | 11234 | 35 | 47 | | 5.6 | |
| FSD0306NB | 35*47*6 HTCR | 09283-35040 | 35 | 47 | | 6 | |
| FSD0823NB | 35*47*6 SC | | 35 | 47 | | 6 | |
| FSD0823FB | 35*47*6 SC(VITON) | | 35 | 47 | | 6 | |
| FSD0728NB | 35*47*6 TC | | 35 | 47 | | 6 | |
| FSD0748NB | 35*47*7 DC | | 35 | 47 | | 7 | |
| FSD0592NB | 35*47*7 HSC(DDN3539) | DDN3539 | 35 | 47 | | 7 | |
| FSD0308NB | 35*47*7 HSCR | | 35 | 47 | | 7 | |
| FSD0308AB | 35*47*7 HSCR (ACM) | | 35 | 47 | | 7 | |
| FSD0308FB | 35*47*7 HSCR (FKM) | | 35 | 47 | | 7 | |
| FSD0309QB | 35*47*7 HTC(VMQ) | | 35 | 47 | | 7 | |
| FSD0310AB | 35*47*7 HTCR(ACM) | 1306333 | 35 | 47 | | 7 | |
| FSD0310QB | 35*47*7 HTCR(VMQ) | 1306333 | 35 | 47 | | 7 | |
| FSD0013NB | 35*47*7 SC(Green) | | 35 | 47 | | 7 | |
| FSD0486NB | 35*47*7 SEB | | 35 | 47 | | 7 | |
| FSD0513NB | 35*47*7 TB | | 35 | 47 | | 7 | |
| FSD0146NB | 35*47*7 TC | | 35 | 47 | | 7 | |
| FSD0146QB | 35*47*7 TC (VMQ) | | 35 | 47 | | 7 | |
| FSD0146FB | 35*47*7 TC(VITON)FKM | | 35 | 47 | | 7 | |
| FSD0864NB | 35*47*7 TZ | | 35 | 47 | | 7 | |
| FSD0603NB | 35*47*8 HTGL | | 35 | 47 | | 8 | |
| FSD0707NB | 35*47*8 SC | | 35 | 47 | | 8 | |
| FSD0865NB | 35*47*8 TB | | 35 | 47 | | 8 | |
| FSD0296NB | 35*47*8 TC | | 35 | 47 | | 8 | |
| FSD0584NB | 35*47*9 TC | | 35 | 47 | | 9 | |
| FSD0104NB | 35*47*10 TC | | 35 | 47 | | 10 | |
| FSD0929NB | 35*47*12 TC | | 35 | 47 | | 12 | |
| FSD0549NB | 36*47*7 TC | | 36 | 47 | | 7 | |
| FSD0895NB | 37*47*7 TC | | 37 | 47 | | 7 | |
| FSD0895FB | 37*47*7 TC(VITON) | | 37 | 47 | | 7 | |
| FSD0786NB | 37*47*9 TC | | 37 | 47 | | 9 | |
| FSD0951NB | 37*47*10 TC | | 37 | 47 | | 10 | |
| FSD0545QB | 38*47*7 HTCR (VMQ) | | 38 | 47 | | 7 | |
| FSD0563NB | 38*47*7 TC | | 38 | 47 | | 7 | |
| FSD0012NB | 38*47*8.5 SB | | 38 | 47 | | 8.5 | |
| FSD0529NB | 38*47*10 SB | 43252-12000/J2000 | 38 | 47 | | 10 | |
| FSD0509NB | 38*47*10 TC | | 38 | 47 | | 10 | |
| FSD0172N0 | 40*47*4 KB | 456150800 | 40 | 47 | | 4 | |
| FSD0815NB | 40*47*4 TC | | 40 | 47 | | 4 | |
| FSD0937N0 | 40*47*4 VC | | 40 | 47 | | 4 | |
| FSD0777NB | 40*47*10 TZ | | 40 | 47 | | 10 | |
| FSD0648NB | 41*47/53*17 SC5Y | 90310-41001 | 41 | 47 | 53 | 17 | |
| FSD0152NB | 33*47.3*10 TA | | 33 | 47.3 | | 10 | |
| FSD0295NB | 33*47.3*10 TC | B/S 9HP | 33 | 47.3 | | 10 | |

| WLK CODE | OIL SEALS | DESCRIPTION | ID | OD1 | OD2 | H1 | H2 |
|-----------|----------------------------|--------------------------|-------|--------|-----|-------|----|
| FSD0493NB | 34.96*47.5*7.9 TC | | 34.96 | 47.5 | | 7.9 | |
| FSD0272NB | 31.7*47.6*11 TC | | 31.7 | 47.6 | | 11 | |
| FSD0322NB | 38.1*47.6*5 TC | | 38.1 | 47.6 | | 5 | |
| FSD0541NB | 28.57*47.62*9.52 TC | | 28.57 | 47.62 | | 9.52 | |
| FSD0542NB | 31.75*47.62*7.93 SC | | 31.75 | 47.62 | | 7.93 | |
| FSD0476NB | 31.75*47.625*6.35 SB | 1.250*1.875*0.250 SB | 31.75 | 47.625 | | 6.35 | |
| FSD0484NB | 31.75*47.625*6.35 SC | 1.250*1.875*0.250 SC | 31.75 | 47.625 | | 6.35 | |
| FSD9902NB | 22.23*47.63*6.35 SC | | 22.23 | 47.63 | | 6.35 | |
| FSD9942NB | 25.4*47.63*6.35 TC | | 25.4 | 47.63 | | 6.35 | |
| FSD9897NB | 25.4*47.63*9.52 SM | | 25.4 | 47.63 | | 9.52 | |
| FSD0896NB | 25.4*47.63*9.53 TC | | 25.4 | 47.63 | | 9.53 | |
| FSD9959NB | 28.58*47.63*6.35 SB | | 28.58 | 47.63 | | 6.35 | |
| FSD9959FB | 28.58*47.63*6.35 SB(VITON) | VITON | 28.58 | 47.63 | | 6.35 | |
| FSD9905NB | 28.58*47.63*6.35 SC | | 28.58 | 47.63 | | 6.35 | |
| FSD9972NB | 28.58*47.63*6.35 TB | | 28.58 | 47.63 | | 6.35 | |
| FSD9933NB | 28.58*47.63*9.53 TC | 1.125*1.875*0.375 TC | 28.58 | 47.63 | | 9.53 | |
| FSD9898NB | 28.58*47.63*11.13 VA | | 28.58 | 47.63 | | 11.13 | |
| FSD9925NB | 30.18*47.63*6.35 SB | | 30.18 | 47.63 | | 6.35 | |
| FSD9925FB | 30.18*47.63*6.35 SB(VITON) | VITON | 30.18 | 47.63 | | 6.35 | |
| FSD9995NB | 30.96*47.63*6.35 SB | 299609 | 30.96 | 47.63 | | 6.35 | |
| FSD9953NB | 31.75*47.63*6.35 TB | | 31.75 | 47.63 | | 6.35 | |
| FSD9929NB | 31.75*47.63*6.35 TC | | 31.75 | 47.63 | | 6.35 | |
| FSD9938N0 | 31.75*47.63*6.35 VB | | 31.75 | 47.63 | | 6.35 | |
| FSD9918NB | 31.75*47.63*9.53 TC | | 31.75 | 47.63 | | 9.53 | |
| FSD9934NB | 34.92*47.63*6.35 SC | | 34.92 | 47.63 | | 6.35 | |
| FSD9951NB | 34.92*47.63*6.35 TC | | 34.92 | 47.63 | | 6.35 | |
| FSD9951FB | 34.92*47.63*6.35 TC(FKM) | VITON | 34.92 | 47.63 | | 6.35 | |
| FSD9998NB | 34.92*47.63*7.95 SZ | 291675 | 34.92 | 47.63 | | 7.95 | |
| FSD0301NB | 34.93*47.63*6.35 HTCW | 1.375*1.875*0.250 HTCW | 34.93 | 47.63 | | 6.35 | |
| FSD9940NB | 34.93*47.63*6.35 SC | 1.375*1.875*0.250 | 34.93 | 47.63 | | 6.35 | |
| FSD9893NB | 34.93*47.63*6.35 TC | | 34.93 | 47.63 | | 6.35 | |
| FSD9946NB | 34.93*47.63*7.95 SB | | 34.93 | 47.63 | | 7.95 | |
| FSD9906NB | 34.93*47.63*7.95 SZ | | 34.93 | 47.63 | | 7.95 | |
| FSD9962NB | 34.93*47.63*7.95 TB | | 34.93 | 47.63 | | 7.95 | |
| FSD9922NB | 34.93*47.63*9.53 TB | | 34.93 | 47.63 | | 9.53 | |
| FSD9915NB | 34.93*47.63*9.53 TC | | 34.93 | 47.63 | | 9.53 | |
| FSD9917NB | 38.1*47.63*4.78 SC | | 38.1 | 47.63 | | 4.78 | |
| FSD9945NB | 38.1*47.63*4.78 TC | | 38.1 | 47.63 | | 4.78 | |
| FSD9969NB | 38.1*47.63*4.78 VB | | 38.1 | 47.63 | | 4.78 | |
| FSD9900NB | 38.1*47.63*6.35 TC | | 38.1 | 47.63 | | 6.35 | |
| FSD0268NB | 30.86*47.65*6.65 TBP | 1.215*1.876*0.262 TBP | 30.86 | 47.65 | | 6.65 | |
| FSD0432NB | 32.39*47.75*8 SB(BH3) | 1.275*1.880*0.315 SB無研 | 32.39 | 47.75 | | 8 | |
| FSD0431NB | 28.32*47.93*6.31 SB(BH1) | 1.115*1.887*0.265 SB(SZ) | 28.32 | 47.93 | | 6.31 | |
| FSD0942NB | 17*48*8 TC | | 17 | 48 | | 8 | |
| FSD0729NB | 20*48*7 TC | | 20 | 48 | | 7 | |
| FSD0011NB | 20*48*8 TC | | 20 | 48 | | 8 | |
| FSD0664NB | 20*48*9 TC | | 20 | 48 | | 9 | |
| FSD0950NB | 20*48*10 TC | | 20 | 48 | | 10 | |
| FSC0525NB | 22*48*7 TC | | 22 | 48 | | 7 | |
| FSC0879NB | 22*48*10 TC | 9121 | 22 | 48 | | 10 | |
| FSD0759NB | 24*48*7 TC | | 24 | 48 | | 7 | |
| FSD0873NB | 24*48*8 TC | | 24 | 48 | | 8 | |
| FSD0596NB | 25*48*7 TC | | 25 | 48 | | 7 | |
| FSD0010NB | 25*48*8 TC | | 25 | 48 | | 8 | |
| FSD0491NB | 25*48*10 TC | | 25 | 48 | | 10 | |
| FSD0733NB | 25*48*10/11 SCYI(Brown) | TOYOTA 1.6-93 4AF | 25 | 48 | | 10 | 11 |
| FSD0526NB | 26*48*7 HPCR | 90311-26001 | 26 | 48 | | 7 | |

| WLK CODE | OIL SEALS | DESCRIPTION | ID | OD1 | OD2 | H1 | H2 |
|-----------|-------------------------|--------------------------|----|-----|-----|-----|------|
| FSD0590NB | 26*48*7 TC | | 26 | 48 | | 7 | |
| FSD0178NB | 26*48*8 TC | | 26 | 48 | | 8 | |
| FSD0593NB | 26*48*10 SCYI (Brown) | 11193-15010 彈簧內包 | 26 | 48 | | 10 | |
| FSD0680NB | 27*48*7 TC | | 27 | 48 | | 7 | |
| FSD0624NB | 27*48*8 TC | | 27 | 48 | | 8 | |
| FSD0807NB | 28*48*6 SC | | 28 | 48 | | 6 | |
| FSD0118NB | 28*48*6 TC BROWN | | 28 | 48 | | 6 | |
| FSD0808N0 | 28*48*6 VB | | 28 | 48 | | 6 | |
| FSD0722NB | 28*48*7 TC | | 28 | 48 | | 7 | |
| FSD0142N0 | 28*48*7 VC | | 28 | 48 | | 7 | |
| FSD0395NB | 28*48*8 TC | AE1544E | 28 | 48 | | 8 | |
| FSD0809NB | 28*48*9 TC | | 28 | 48 | | 9 | |
| FSD0469NB | 28*48*10 TC | | 28 | 48 | | 10 | |
| FSD0008NB | 28*48*11 TC | IDVA | 28 | 48 | | 11 | |
| FSD0811NB | 30*48*6 SC | | 30 | 48 | | 6 | |
| FSD0810N0 | 30*48*6 VB | | 30 | 48 | | 6 | |
| FSD0703NB | 30*48*7 TC | | 30 | 48 | | 7 | |
| FSD0746NB | 30*48*8 DC | | 30 | 48 | | 8 | |
| FSD0007NB | 30*48*8 TC | | 30 | 48 | | 8 | |
| FSD0284NB | 30*48*10 TB | | 30 | 48 | | 10 | |
| FSD0265NB | 30*48*10 TC | | 30 | 48 | | 10 | |
| FSD0768NB | 31*48*10 HTCL | | 31 | 48 | | 10 | |
| FSD0216NB | 32*48*6 TC(BROWN) | | 32 | 48 | | 6 | |
| FSD0291NB | 32*48*7 HTCR | 90043-11109, 90311-32013 | 32 | 48 | | 7 | |
| FSD0291AB | 32*48*7 HTCR(ACM) | | 32 | 48 | | 7 | |
| FSD0417NB | 32*48*7 TC | 90043-11109 | 32 | 48 | | 7 | |
| FSD0417FB | 32*48*7 TC(VITON) | | 32 | 48 | | 7 | |
| FSD0370NB | 32*48*8 HTCR | | 32 | 48 | | 8 | |
| FSD0734NB | 32*48*8 TB | | 32 | 48 | | 8 | |
| FSD0006NB | 32*48*8 TC | NM155/180 起動 | 32 | 48 | | 8 | |
| FSD0006NS | 32*48*8 TC(S304 SPRING) | SUS304 SPRING | 32 | 48 | | 8 | |
| FSD0006FB | 32*48*8 TC(VITON) | | 32 | 48 | | 8 | |
| FSD0553NB | 32*48*9/15.5 TC9Y | 90311-32006 | 32 | 48 | | 9 | 15.5 |
| FSD0560NB | 32*48*10 HTCL | MD-701430 | 32 | 48 | | 10 | |
| FSD0792NB | 32*48*10 TC | | 32 | 48 | | 10 | |
| FSD0005NB | 33*48*8 TC | 13042-D0100 | 33 | 48 | | 8 | |
| FSD0297NB | 34*48*7 HTCR | F801-10-602, FE01-10-602 | 34 | 48 | | 7 | |
| FSD0297AB | 34*48*7 HTCR(ACM) | | 34 | 48 | | 7 | |
| FSD0298NB | 34*48*7 TC | FE01-10-602 | 34 | 48 | | 7 | |
| FSD0299NB | 34*48*8 HTCR | 13042-16A05 | 34 | 48 | | 8 | |
| FSD0299QB | 34*48*8 HTCR(VMQ) | | 34 | 48 | | 8 | |
| FSD0727NB | 34*48*8 TC | | 34 | 48 | | 8 | |
| FSD0874NB | 35*48*6 TC | | 35 | 48 | | 6 | |
| FSD0568NB | 35*48*6.5 HTCR | 90311-35023 | 35 | 48 | | 6.5 | |
| FSD0670NB | 35*48*7 HTBCR | OPEL 636841, 636838 | 35 | 48 | | 7 | |
| FSD0311NB | 35*48*7 HTCR | | 35 | 48 | | 7 | |
| FSD0311QB | 35*48*7 HTCR (VMQ) | | 35 | 48 | | 7 | |
| FSD0312NB | 35*48*7 TC | 90311-35001 | 35 | 48 | | 7 | |
| FSD0312FB | 35*48*7 TC(VITON) | | 35 | 48 | | 7 | |
| FSD0313NB | 35*48*8 HTCR | 21421-22001 | 35 | 48 | | 8 | |
| FSD0313QB | 35*48*8 HTCR (VMQ) | | 35 | 48 | | 8 | |
| FSD0621NB | 35*48*8 TB | | 35 | 48 | | 8 | |
| FSD0004NB | 35*48*8 TC | GA70/NM55 曲軸 | 35 | 48 | | 8 | |
| FSD0004FB | 35*48*8 TC(VITON) | | 35 | 48 | | 8 | |
| FSD0866NB | 35*48*8 TZ | | 35 | 48 | | 8 | |
| FSD0482NB | 35*48*8/9.5 TC4Y | GCDC0001 | 35 | 48 | | 8 | 9.5 |

| WLK CODE | OIL SEALS | DESCRIPTION | ID | OD1 | OD2 | H1 | H2 |
|-----------|-------------------------|-------------------------|-------|-------|------|------|------|
| FSD0314NB | 35*48*10 HTCR | | 35 | 48 | | 10 | |
| FSD0314QB | 35*48*10 HTCR (VMQ) | | 35 | 48 | | 10 | |
| FSD0406NB | 35*48*10 TG | | 35 | 48 | | 10 | |
| FSD0003NB | 35*48*10.5 SC | | 35 | 48 | | 10.5 | |
| FSD0715NB | 35*48*11 DC | | 35 | 48 | | 11 | |
| FSD0802NB | 35*48*11 TC | | 35 | 48 | | 11 | |
| FSD0002NB | 35*48*11 TC4 NBR80 | 1T323-14500 | 35 | 48 | | 11 | |
| FSD0455NB | 35*48*13/15 TBC45 | 0437-17-335 | 35 | 48 | | 13 | 15 |
| FSD0702NB | 35*48/55*13/15 TBC45 | 35X48X13/15 TBC45 | 35 | 48 | 55 | 13 | 15 |
| FSD0883NB | 36*48*7 TC | | 36 | 48 | | 7 | |
| FSD0878NB | 36*48*8/9.5 TC | | 36 | 48 | | 8 | 9.5 |
| FSD0318NB | 36*48*9.5 TC | | 36 | 48 | | 9.5 | |
| FSD0174NB | 36*48*10 TC | | 36 | 48 | | 10 | |
| FSD0773NB | 37*48*6 TC | | 37 | 48 | | 6 | |
| FSD0163NB | 38*48*4 VB | | 38 | 48 | | 4 | |
| FSD0557NB | 38*48*6 TC | | 38 | 48 | | 6 | |
| FSD0611NB | 38*48*7 TC | | 38 | 48 | | 7 | |
| FSD0574NB | 38*48*8 TC | | 38 | 48 | | 8 | |
| FSD0625NB | 38*48*10 TC | | 38 | 48 | | 10 | |
| FSD0218N0 | 40*48*6 VB | | 40 | 48 | | 6 | |
| FSD0203NB | 25*48.5*7 TC | | 25 | 48.5 | | 7 | |
| FSD0204NB | 25*48.5*10 TC | | 25 | 48.5 | | 10 | |
| FSD9907N0 | 28.6*48.5*3.1/10.8 Y | 豐田2.0 3S-FE火星塞橡皮 | 28.6 | 48.5 | | 3.1 | 10.8 |
| FSD0266NB | 30*48.5*7 TC | | 30 | 48.5 | | 7 | |
| FSD0481NS | 35*48.5/52.5*4.5/14 Y | GCDC0002 | 35 | 48.5 | 52.5 | 4.5 | 14 |
| FSD0858NB | 20*49*7 TC | | 20 | 49 | | 7 | |
| FSD0760NB | 24*49*12 TC | | 24 | 49 | | 12 | |
| FSD0669NB | 25*49*10 TC | | 25 | 49 | | 10 | |
| FSD0205NB | 25*49*10/15 TCY | 113PH04 | 25 | 49 | | 10 | 15 |
| FSD0551NB | 27*49*7.5 SC | 13276-53Y10, MARCH 1.3 | 27 | 49 | | 7.5 | |
| FSD0688NB | 27*49*10 SC | | 27 | 49 | | 10 | |
| FSD0732NB | 27*49*10/11 SCYI(Brown) | NISSAN SENTRA 331 91-96 | 27 | 49 | | 10 | 11 |
| FSD0502NB | 28*49*7 TC | | 28 | 49 | | 7 | |
| FSD0765NB | 30*49*7 TC | | 30 | 49 | | 7 | |
| FSD0769NB | 31*49*7 TC | | 31 | 49 | | 7 | |
| FSD0656NB | 33*49*8 HTCR | | 33 | 49 | | 8 | |
| FSD0511AB | 33*49*8 HTCR (PA) | (ACM) | 33 | 49 | | 8 | |
| FSD0315NB | 35*49*6 HTCR | 90311-35013/03,NJ353 | 35 | 49 | | 6 | |
| FSD0315QB | 35*49*6 HTCR(VMQ) | 5974 | 35 | 49 | | 6 | |
| FSD0448NB | 35*49*6 TC | (RS006) | 35 | 49 | | 6 | |
| FSD0219NB | 35*49*7 HTCR | | 35 | 49 | | 7 | |
| FSD0731NB | 35*49*8 TC | | 35 | 49 | | 8 | |
| FSD0130NB | 35*49*12.5 HTCL | 9-09724-004-0 | 35 | 49 | | 12.5 | |
| FSD0426NB | 36*49*7 HTCR | 13510-01M00 | 36 | 49 | | 7 | |
| FSD0426AB | 36*49*7 HTCR(ACM) | | 36 | 49 | | 7 | |
| FSD0426QB | 36*49*7 HTCR(VMQ) | | 36 | 49 | | 7 | |
| FSD0889NB | 37*49*8/9 TC | | 37 | 49 | | 8 | 9 |
| FSD0319NB | 37*49*10 TC | | 37 | 49 | | 10 | |
| FSD0706NB | 38*49*8/12 SPHTCL | 38*49.2*9(8/12) SPHTCL | 38 | 49 | | 8 | 12 |
| FSD0778NB | 40*49*6 TZ | | 40 | 49 | | 6 | |
| FSD0519NB | 40*49*10.3 SB | | 40 | 49 | | 10.3 | |
| FSD0604NB | 35*49.2*12.5 HTCL | 8-94223-026-0 | 35 | 49.2 | | 12.5 | |
| FSD0897NB | 38*49.2*8/12 TCY | | 38 | 49.2 | | 8 | 12 |
| FSD0323NB | 38.1*49.2*9 TC | | 38.1 | 49.2 | | 9 | |
| FSD0325QB | 40*49.2*6 TB (VMQ) | | 40 | 49.2 | | 6 | |
| FSD0128NB | 38*49.21*9 TB | 5-09625-062-1 | 38 | 49.21 | | 9 | |
| FSD9982NB | 41.28*49.23*6.35 TB | | 41.28 | 49.23 | | 6.35 | |

| WLK CODE | OIL SEALS | DESCRIPTION | ID | OD1 | OD2 | H1 | H2 |
|------------|--------------------------|---------------------------|-------|-------|-----|------|----|
| FSD0325NB | 40*49.3*6 TB | | 40 | 49.3 | | 6 | |
| FSD0444NB | 40.87*49.35*6.35 TB(Red) | 1.609*1.943*0.25 TB | 40.87 | 49.35 | | 6.35 | |
| FSD0327NB | 41.28*49.40*6.35 TB | 1.625*1.945*0.250 TB | 41.28 | 49.4 | | 6.35 | |
| FSD0327QB | 41.28*49.40*6.35 TB(VMQ) | 1.625*1.945*0.250 TB(VMQ) | 41.28 | 49.4 | | 6.35 | |
| FSD9948NB | 34.92*49.41*12.7 TZ | 11237 | 34.92 | 49.41 | | 12.7 | |
| FSD0106NB | 34.92*49.5*12.7 HTGL | | 34.92 | 49.5 | | 12.7 | |
| FSD0316NB | 35*49.5*12 TC | | 35 | 49.5 | | 12 | |
| FSD0326NB | 40*49.5*6.3 SB | | 40 | 49.5 | | 6.3 | |
| FSD0001NB | 34*49.62*12.7 TB | | 34 | 49.62 | | 12.7 | |
| FSD0876NB | 20*50*7 SC | | 20 | 50 | | 7 | |
| FSD0695NB | 20*50*7 TC | | 20 | 50 | | 7 | |
| FSE0378NB | 20*50*8 TC | | 20 | 50 | | 8 | |
| FSD0379NB | 20*50*10 TC | | 20 | 50 | | 10 | |
| FSD0947NB | 20*50*12 TC | | 20 | 50 | | 12 | |
| FSD0382NB | 22*50*8 TC | | 22 | 50 | | 8 | |
| FSD0383NB | 22*50*10 TC | | 22 | 50 | | 10 | |
| FSD0719NB | 24*50*10 TC | | 24 | 50 | | 10 | |
| FSD0577NB | 24.5*50*9 TC | 03AT37 | 24.5 | 50 | | 9 | |
| FSD0387NB | 25*50*7 TC | | 25 | 50 | | 7 | |
| FSD0387FB | 25*50*7 TC(VITON) | | 25 | 50 | | 7 | |
| FSD0371NB | 25*50*8 TC | | 25 | 50 | | 8 | |
| FSD0345NB | 25*50*9 TC | | 25 | 50 | | 9 | |
| FSD0388NB | 25*50*10 TC | 113LG81 | 25 | 50 | | 10 | |
| FSD0388FB | 25*50*10 TC(VITON) | | 25 | 50 | | 10 | |
| FSD0422NB | 25*50*12 TC | | 25 | 50 | | 12 | |
| FSD0422FB | 25*50*12 TC(VITON) | | 25 | 50 | | 12 | |
| FSE0643NB | 27*50*10 TC | | 27 | 50 | | 10 | |
| FSD0918NB | 28*50*6 TC | | 28 | 50 | | 6 | |
| FSD0853NB | 28*50*7 TC | | 28 | 50 | | 7 | |
| FSD0397NB | 28*50*8 TC | | 28 | 50 | | 8 | |
| FSD0397FB | 28*50*8 TC(VITON) | | 28 | 50 | | 8 | |
| FSD0396NB | 28*50*10 TC | | 28 | 50 | | 10 | |
| FSD0704NB | 29*50*8 TC | | 29 | 50 | | 8 | |
| FSD0504NB | 29*50*10 TC | | 29 | 50 | | 10 | |
| FSD0854NB | 30*50*5 TC | | 30 | 50 | | 5 | |
| FSD0077NB | 30*50*7 SC | | 30 | 50 | | 7 | |
| FSD0077FB | 30*50*7 SC(VITON) | TC修掉副唇 | 30 | 50 | | 7 | |
| FSD0346NB | 30*50*7 TC | | 30 | 50 | | 7 | |
| FSD0346FB | 30*50*7 TC(VITON) | | 30 | 50 | | 7 | |
| FSD0346QB | 30*50*7 TC(VMQ) | | 30 | 50 | | 7 | |
| FSD0340NB | 30*50*8 TC | KF64, 0624-30508 | 30 | 50 | | 8 | |
| FSD0340NS | 30*50*8 TC(S304SPRING) | SUS304 SPRING | 30 | 50 | | 8 | |
| FSD0237NB | 30*50*8 TCY | | 30 | 50 | | 8 | |
| FSD0685NB | 30*50*10 DC | 友祥專用 | 30 | 50 | | 10 | |
| FSD0339NB | 30*50*10 SC | N12 曲軸 | 30 | 50 | | 10 | |
| FSD0339FB | 30*50*10 SC(VITON)FKM | | 30 | 50 | | 10 | |
| FSD0339QB | 30*50*10 SC(VMQ) | | 30 | 50 | | 10 | |
| FSD0338NB | 30*50*10 TC | BOOSTER NISSAN | 30 | 50 | | 10 | |
| FSD0338NS | 30*50*10 TC(S304SPRING) | SUS304 SPRING | 30 | 50 | | 10 | |
| FSD0338NSS | 30*50*10 TC(SUS)+INSERT | | 30 | 50 | | 10 | |
| FSD0338FB | 30*50*10 TC(VITON) | | 30 | 50 | | 10 | |
| FSD0605NB | 30*50/57*10 TC5 | | 30 | 50 | 57 | 10 | |
| FSD0337NB | 30*50*11 TC | AXEL HINO FF | 30 | 50 | | 11 | |
| FSD0337NS | 30*50*11 TC(S304SPRING) | SUS304 SPRING | 30 | 50 | | 11 | |
| FSD0337FB | 30*50*11 TC(VITON) | | 30 | 50 | | 11 | |
| FSD0535NB | 30*50*11 TCN NBR85 | AP1709H | 30 | 50 | | 11 | |
| FSD0495NB | 30*50*11/12 TG | | 30 | 50 | | 11 | 12 |

| WLK CODE | OIL SEALS | DESCRIPTION | ID | OD1 | OD2 | H1 | H2 |
|-----------|-------------------------|-------------------------|----|-----|-----|-----|------|
| FSD0348NB | 30*50*12 DC | | 30 | 50 | | 12 | |
| FSD0894NB | 30*50*12 SB | | 30 | 50 | | 12 | |
| FSD0677NB | 30*50*12 TC | | 30 | 50 | | 12 | |
| FSD0349QB | 31*50*8 HTCR (VMQ) | 外徑有紋路 | 31 | 50 | | 8 | |
| FSD0349NB | 31*50*8 HTCR(HTGR) | 外徑有紋路 | 31 | 50 | | 8 | |
| FSD0614NB | 31*50*8 TC | | 31 | 50 | | 8 | |
| FSD0494NB | 32*50*7 TC | | 32 | 50 | | 7 | |
| FSD0671NB | 32*50*8 HTCR | 62525 | 32 | 50 | | 8 | |
| FSD0671AB | 32*50*8 HTCR(ACM) | 12740 | 32 | 50 | | 8 | |
| FSD0671QB | 32*50*8 HTCR(VMQ) | | 32 | 50 | | 8 | |
| FSD0330NB | 32*50*8 TC | | 32 | 50 | | 8 | |
| FSD0330NS | 32*50*8 TC(S304 SPRING) | | 32 | 50 | | 8 | |
| FSD0330FB | 32*50*8 TC(VITON) | | 32 | 50 | | 8 | |
| FSD0738NB | 32*50*9/11.3 TC69Y | | 32 | 50 | | 9 | 11.3 |
| FSD0555NB | 32*50*10 SC | | 32 | 50 | | 10 | |
| FSD0418NB | 32*50*10 TC | | 32 | 50 | | 10 | |
| FSD0418QB | 32*50*10 TC (VMQ) | | 32 | 50 | | 10 | |
| FSD0418FB | 32*50*10 TC(VITON)FKM | | 32 | 50 | | 10 | |
| FSD0825NB | 32*50*12 SC | | 32 | 50 | | 12 | |
| FSD0723NB | 32*50*12 TC | | 32 | 50 | | 12 | |
| FSD0721NB | 33*50*6 TC | | 33 | 50 | | 6 | |
| FSD0712NB | 33*50*7 TC | | 33 | 50 | | 7 | |
| FSD0657NB | 33*50*8 SC | | 33 | 50 | | 8 | |
| FSD0350NB | 33*50*8 TB | | 33 | 50 | | 8 | |
| FSD0538NB | 33*50*8 TC | | 33 | 50 | | 8 | |
| FSD0342NB | 33*50*10 HTBL | 11056989C | 33 | 50 | | 10 | |
| FSD0506NB | 33*50*10 TC | | 33 | 50 | | 10 | |
| FSD0558NB | 33*50*12 TC | | 33 | 50 | | 12 | |
| FSE0466NB | 34*50*7 HSCR | 32113-N2101 | 34 | 50 | | 7 | |
| FSD0438NB | 34*50*7 HTCR | ME-620713 | 34 | 50 | | 7 | |
| FSD0438AB | 34*50*7 HTCR(ACM) | | 34 | 50 | | 7 | |
| FSD0508NB | 34*50*7 TC | | 34 | 50 | | 7 | |
| FSD0570NB | 34*50*8 TC | | 34 | 50 | | 8 | |
| FSD0404NB | 34*50*10 TC | | 34 | 50 | | 10 | |
| FSD0407NB | 35*50*7 TC | | 35 | 50 | | 7 | |
| FSD0407FB | 35*50*7 TC(VITON) | | 35 | 50 | | 7 | |
| FSD0474N0 | 35*50*7.5/9.5 KC9Y | | 35 | 50 | | 7.5 | 9.5 |
| FSD0351NB | 35*50*8 HTCL | 91212-611-003 | 35 | 50 | | 8 | |
| FSD0351QB | 35*50*8 HTCL(VMQ) | | 35 | 50 | | 8 | |
| FSD0352NB | 35*50*8 HTCR | MD-008762 | 35 | 50 | | 8 | |
| FSD0351AB | 35*50*8 HTCR(ACM) | | 35 | 50 | | 8 | |
| FSD0352QB | 35*50*8 HTCR(VMQ) | | 35 | 50 | | 8 | |
| FSD0353NB | 35*50*8 TB(TM) | | 35 | 50 | | 8 | |
| FSD0336NB | 35*50*8 TC | | 35 | 50 | | 8 | |
| FSD0336NS | 35*50*8 TC(S304 SPRING) | SUS304 SPRING | 35 | 50 | | 8 | |
| FSD0336QB | 35*50*8 TC(VMQ) | | 35 | 50 | | 8 | |
| FSD0354NB | 35*50*9 TC | | 35 | 50 | | 9 | |
| FSD0354QB | 35*50*9 TC (VMQ) | | 35 | 50 | | 9 | |
| FSD0441NB | 35*50*9.5 AES-S | 90310-35005,90311-35024 | 35 | 50 | | 9.5 | |
| FSD0089NB | 35*50*10 HTCR | 7703087097 | 35 | 50 | | 10 | |
| FSD0355NB | 35*50*10 SC | | 35 | 50 | | 10 | |
| FSD0335NB | 35*50*10 TC | | 35 | 50 | | 10 | |
| FSD0335FB | 35*50*10 TC(VITON) | | 35 | 50 | | 10 | |
| FSD0749NB | 35*50*11 DC | | 35 | 50 | | 11 | |
| FSD0437NB | 35*50*11 HTCL | 32136-U0100/07200 | 35 | 50 | | 11 | |
| FSD0437AB | 35*50*11 HTCL(ACM) | | 35 | 50 | | 11 | |
| FSD0437QB | 35*50*11 HTCL(VMQ) | | 35 | 50 | | 11 | |

| WLK CODE | OIL SEALS | DESCRIPTION | ID | OD1 | OD2 | H1 | H2 |
|-----------|----------------------|----------------------|-------|-------|-----|------|----|
| FSD0427NB | 35*50*11 HTCR | | 35 | 50 | | 11 | |
| FSD0427QB | 35*50*11 HTCR(VMQ) | | 35 | 50 | | 11 | |
| FSD0356NB | 35*50*11 TC | | 35 | 50 | | 11 | |
| FSD0534NB | 35*50*11.5 HTCR5Y | BH3290E | 35 | 50 | | 11.5 | |
| FSD0867NB | 35*50*12 SB | | 35 | 50 | | 12 | |
| FSD0681NB | 35*50*12 TC | | 35 | 50 | | 12 | |
| FSD0420NB | 36*50*7 SC | 90311-36104 | 36 | 50 | | 7 | |
| FSD0420FB | 36*50*7 SC(VITON) | TC修掉副唇 | 36 | 50 | | 7 | |
| FSD0554NB | 36*50*7 TA | 90311-36001 | 36 | 50 | | 7 | |
| FSD0461NB | 36*50*7 TC | | 36 | 50 | | 7 | |
| FSD0461FB | 36*50*7 TC(VITON) | | 36 | 50 | | 7 | |
| FSD0358NB | 36*50*8 HTCL | 13042-16A10 | 36 | 50 | | 8 | |
| FSD0814NB | 36*50*8 TC | | 36 | 50 | | 8 | |
| FSD0907NB | 36*50*10 SC | | 36 | 50 | | 10 | |
| FSD0793NB | 36*50*10 TC | | 36 | 50 | | 10 | |
| FSD0515NB | 37*50*6 HTBR | 9828-37103 | 37 | 50 | | 6 | |
| FSD0817NB | 37*50*6 HTCR | MD-088855 | 37 | 50 | | 6 | |
| FSD0817QB | 37*50*6 HTCR(VMQ) | | 37 | 50 | | 6 | |
| FSD0359NB | 37*50*6 TB | | 37 | 50 | | 6 | |
| FSD0334NB | 37*50*6.2 HTBR | 9828-37013 | 37 | 50 | | 6.2 | |
| FSD0408NB | 37*50*7 TC | | 37 | 50 | | 7 | |
| FSD0774NB | 37*50*10 SC | | 37 | 50 | | 10 | |
| FSD0750NB | 37*50*11 DC | | 37 | 50 | | 11 | |
| FSD0708NB | 37.5*50*6 HTCR | | 37.5 | 50 | | 6 | |
| FSD0949NB | 38*50*6 HTCL | | 38 | 50 | | 6 | |
| FSD0360NB | 38*50*6 HTCR | 90311-38025 | 38 | 50 | | 6 | |
| FSD0705NB | 38*50*7 DC | | 38 | 50 | | 7 | |
| FSD0640NB | 38*50*7 HTCL | | 38 | 50 | | 7 | |
| FSD0332NB | 38*50*7 SC | | 38 | 50 | | 7 | |
| FSD0332QB | 38*50*7 SC (VMQ) | | 38 | 50 | | 7 | |
| FSD0333NB | 38*50*7 TC | | 38 | 50 | | 7 | |
| FSD0333FB | 38*50*7 TC(FKM)VITON | | 38 | 50 | | 7 | |
| FSD0333QB | 38*50*7 TC(VMQ) | (VMQ) | 38 | 50 | | 7 | |
| FSD0361NB | 38*50*8 HTCR | 90311-38017 | 38 | 50 | | 8 | |
| FSD0361QB | 38*50*8 HTCR(VMQ) | | 38 | 50 | | 8 | |
| FSD0531NB | 38*50*8 TB | | 38 | 50 | | 8 | |
| FSD0362NB | 38*50*8 TC | 29972-80050 | 38 | 50 | | 8 | |
| FSD0622NB | 38*50*8 TC4 | | 38 | 50 | | 8 | |
| FSD0409NB | 38*50*10 TC | | 38 | 50 | | 10 | |
| FSD0343NB | 39*50*7 TC | G030-26-154A;M4564 | 39 | 50 | | 7 | |
| FSD0798NB | 39*50*9 TB | | 39 | 50 | | 9 | |
| FSD0898NB | 39*50*10 TC | | 39 | 50 | | 10 | |
| FSD0331N0 | 40*50*4 KB | | 40 | 50 | | 4 | |
| FSD0615NB | 40*50*4 TC | | 40 | 50 | | 4 | |
| FSD0804N0 | 40*50*4 VB | | 40 | 50 | | 4 | |
| FSD0559NB | 40*50*5 TC | | 40 | 50 | | 5 | |
| FSD0850NB | 40*50*6 TZ | | 40 | 50 | | 6 | |
| FSD0885N0 | 40*50*6 VB | | 40 | 50 | | 6 | |
| FSD0585NB | 40*50*6.5 TC | | 40 | 50 | | 6.5 | |
| FSD0364NB | 40*50*7 SC | | 40 | 50 | | 7 | |
| FSD0365NB | 40*50*7 TC | | 40 | 50 | | 7 | |
| FSD0527NB | 40*50*8 TC | | 40 | 50 | | 8 | |
| FSD0449NB | 40*50*10 TC | | 40 | 50 | | 10 | |
| FSD0779NB | 42*50*7 TC | | 42 | 50 | | 7 | |
| FSD0788NB | 42*50*8 TZ | | 42 | 50 | | 8 | |
| FSD0446NB | 43*50*9 KM(KB) | W025 26 157 | 43 | 50 | | 9 | |
| FSE9990NB | 31.75*50.04*6.35 TB | 1.250*1.970*0.250 TB | 31.75 | 50.04 | | 6.35 | |

| WLK CODE | OIL SEALS | DESCRIPTION | ID | OD1 | OD2 | H1 | H2 |
|-----------|---------------------------|--------------------------|--------|-------|-----|-------|-----|
| FSE9980NB | 31.75*50.27*6.35 TB | 1.250*1.979*0.250 TB | 31.75 | 50.27 | | 6.35 | |
| FSE0716NB | 38*50.3*10 KB | 43252-01B00 | 38 | 50.3 | | 10 | |
| FSE0147NB | 34.93*50.37*7.95 SBP | 1.375*1.983*0.313 SBP | 34.93 | 50.37 | | 7.95 | |
| FSE0174N0 | 38.1*50.42*10.8 KB | 1.500*1.985*0.425 KB | 38.1 | 50.42 | | 10.8 | |
| FSD0099N0 | 32*50.45*9.25 | | 32 | 50.45 | | 9.25 | |
| FSE0806NB | 26.5*50.5*7 TC | | 26.5 | 50.5 | | 7 | |
| FSE0514NB | 36.5*50.5*7 HTCR | OB3C7-10-602A | 36.5 | 50.5 | | 7 | |
| FSE0514QB | 36.5*50.5*7 HTCR(VMQ) | BH4592E | 36.5 | 50.5 | | 7 | |
| FSE0619NB | 36.5*50.5*7 TB | | 36.5 | 50.5 | | 7 | |
| FSE0545NB | 36.5*50.5*7 TC | | 36.5 | 50.5 | | 7 | |
| FSE0611NB | 39*50.5*7 TC(BROWN) | | 39 | 50.5 | | 7 | |
| FSE0555NB | 39*50.5*8.5 TB(TZ) | G030-26-154/A | 39 | 50.5 | | 8.5 | |
| FSE0702NB | 39*50.5*8.5 TZC | | 39 | 50.5 | | 8.5 | |
| FSE0698NB | 25*50.55*10 TC | 03AT90 | 25 | 50.55 | | 10 | |
| FSD0516NB | 39*50.55*8.5 TB | | 39 | 50.55 | | 8.5 | |
| FSE0065NB | 31.8*50.7*9.5 Y | 1.252*1.996*0.374 Y | 31.8 | 50.7 | | 9.5 | |
| FSD9967NB | 25.4*50.8*6.35 KB | 1.000*2.000*0.250 KB | 25.4 | 50.8 | | 6.35 | |
| FSD9980NB | 25.4*50.8*6.35 SC | | 25.4 | 50.8 | | 6.35 | |
| FSD9952NB | 25.4*50.8*6.35 TB | | 25.4 | 50.8 | | 6.35 | |
| FSD0475NB | 25.4*50.8*6.35 TC | 1.000*2.000*0.250 TC | 25.4 | 50.8 | | 6.35 | |
| FSD9956NB | 25.4*50.80*6.35 TB | | 25.4 | 50.8 | | 6.35 | |
| FSC9995NB | 25.4*50.8*9.52 SC | | 25.4 | 50.8 | | 9.52 | |
| FSC0632NB | 25.4*50.8*9.53 TB | | 25.4 | 50.8 | | 9.53 | |
| FSC9997NB | 25.4*50.8*9.53 TC | 1.000*2.000*0.375 TC | 25.4 | 50.8 | | 9.53 | |
| FSD9911NB | 25.4*50.8*12.7 TC | | 25.4 | 50.8 | | 12.7 | |
| FSC0445NB | 25.4*50.8*13.49 DBX | 1.000*2.000*0.531 DBX | 25.4 | 50.8 | | 13.49 | |
| FSE9928NB | 27*50.8*11.51 TA | | 27 | 50.8 | | 11.51 | |
| FSE0498NB | 28.57*50.80*9.52 TC | | 28.57 | 50.8 | | 9.52 | |
| FSE0498FB | 28.57*50.80*9.52 TC(FKM) | VITON | 28.57 | 50.8 | | 9.52 | |
| FSE0505NB | 28.575*50.8*6.35 TA | 1.125*2.000*0.250 TA | 28.575 | 50.8 | | 6.35 | |
| FSE9978NB | 28.58*50.8*6.35 TA | 471763 | 28.58 | 50.8 | | 6.35 | |
| FSE9934NB | 28.58*50.8*6.35 TB | | 28.58 | 50.8 | | 6.35 | |
| FSE9977NB | 28.58*50.8*6.35 TC | | 28.58 | 50.8 | | 6.35 | |
| FSE9977FB | 28.58*50.8*6.35 TC(VITON) | VITON | 28.58 | 50.8 | | 6.35 | |
| FSE1099NB | 28.58*50.8*9.53 TB | | 28.58 | 50.8 | | 9.53 | |
| FSE0817NB | 28.58*50.8*9.53 TC | | 28.58 | 50.8 | | 9.53 | |
| FSE9976NB | 28.58*50.8*11.13 SC | 1.125*2.000*0.437 SC | 28.58 | 50.8 | | 11.13 | |
| FSE0486NB | 29.97*50.8*6.35 TC | 1.18*2.00*0.25 TC | 29.97 | 50.8 | | 6.35 | |
| FSD0485NB | 30.16*50.8*7.93 SC | | 30.16 | 50.8 | | 7.93 | |
| FSE9964NB | 30.18*50.8*6.35 TC | 1.188*2.000*0.250 TC | 30.18 | 50.8 | | 6.35 | |
| FSE9879NB | 30.18*50.8*9.53 TC | | 30.18 | 50.8 | | 9.53 | |
| FSD0528P0 | 30.56*50.8*8.74 KA3J PTFE | 1.203*2*0.344 KA3J鐵氟龍 | 30.56 | 50.8 | | 8.74 | |
| FSE0063NB | 31.7*50.8*9.5 TC | 1.248*2.000*0.374 TC | 31.7 | 50.8 | | 9.5 | |
| FSE0406NB | 31.75*50.8*6.35 TB | 1.250*2.000*0.250 TB | 31.75 | 50.8 | | 6.35 | |
| FSE9998NB | 31.75*50.8*6.35 TC | 1.250*2.000*0.250 TC | 31.75 | 50.8 | | 6.35 | |
| FSE9998FB | 31.75*50.8*6.35 TC(VITON) | 1.250*2.000*0.250(VITON) | 31.75 | 50.8 | | 6.35 | |
| FSE9915NB | 31.75*50.8*7/7.5 TCV | | 31.75 | 50.8 | | 7 | 7.5 |
| FSE9995NB | 31.75*50.8*7.9 TC | 1.250*2.000*0.311 TC | 31.75 | 50.8 | | 7.9 | |
| FSE9947NB | 31.75*50.8*7.93 TC | | 31.75 | 50.8 | | 7.93 | |
| FSE0541NB | 31.75*50.8*9.5 TB | | 31.75 | 50.8 | | 9.5 | |
| FSE0137NB | 31.75*50.8*9.5 TC | 1.250*2.000*0.374 TC | 31.75 | 50.8 | | 9.5 | |
| FSE9996NB | 31.75*50.8*9.525 TC | 1.250*2.000*0.375 TC | 31.75 | 50.8 | | 9.525 | |
| FSE9884NB | 31.75*50.8*9.53 TA | | 31.75 | 50.8 | | 9.53 | |
| FSE9958NB | 31.75*50.8*9.53 TB | | 31.75 | 50.8 | | 9.53 | |
| FSE0138NB | 31.75*50.8*9.53 TB3 | 1.250*2.000*0.375 TB3 | 31.75 | 50.8 | | 9.53 | |
| FSE0681NB | 31.75*50.8*9.53 TC | | 31.75 | 50.8 | | 9.53 | |
| FSE0480NB | 31.75*50.8*10.9 TC | | 31.75 | 50.8 | | 10.9 | |

| WLK CODE | OIL SEALS | DESCRIPTION | ID | OD1 | OD2 | H1 | H2 |
|-----------|-----------------------------------|--------------------------|--------|------|-----|-------|-------|
| FSE0481NB | 31.75*50.8*11.1 TA Red Painting | 1.250*2.000*0.437 TA | 31.75 | 50.8 | | 11.1 | |
| FSE9994NB | 31.75*50.8*11.1 TB | 1.250*2.000*0.437 TB | 31.75 | 50.8 | | 11.1 | |
| FSE9979NB | 31.75*50.8*11.13 TA | | 31.75 | 50.8 | | 11.13 | |
| FSE9979FB | 31.75*50.8*11.13 TA(FKM) | VITON | 31.75 | 50.8 | | 11.13 | |
| FSE9944NB | 31.75*50.8*11.13 TM(TB) | | 31.75 | 50.8 | | 11.13 | |
| FSE9944FB | 31.75*50.8*11.13 TM(VITO) | VITON | 31.75 | 50.8 | | 11.13 | |
| FSE0139NB | 31.75*50.8*11.9/14.18TBC | 1.25*2.00*0.468/0.558TBC | 31.75 | 50.8 | | 11.9 | 14.18 |
| FSE0140NB | 31.75*50.8*11.99 TC | 1.250*2.000*0.472 TC | 31.75 | 50.8 | | 11.99 | |
| FSE9991NB | 31.75*50.8*12.7 TC | 1.250*2.000*0.500 TC | 31.75 | 50.8 | | 12.7 | |
| FSE9878NB | 32.94*50.8*7.95 TB | | 32.94 | 50.8 | | 7.95 | |
| FSE9982FS | 34.798*50.8*7.874 TCV(FKM) | 1.370*2.000*0.310 TCV(FK | 34.798 | 50.8 | | 7.874 | |
| FSE9868NB | 34.92*50.8*6.35 TC | | 34.92 | 50.8 | | 6.35 | |
| FSE9987NB | 34.92*50.8*7.95 TB | | 34.92 | 50.8 | | 7.95 | |
| FSE9987FB | 34.92*50.8*7.95 TB(VITON) | VITON | 34.92 | 50.8 | | 7.95 | |
| FSE9997NB | 34.925*50.8*7.94 TA | | 34.925 | 50.8 | | 7.94 | |
| FSE9982NB | 34.925*50.8*7.95 SB | 1.375*2.000*0.313 SB | 34.925 | 50.8 | | 7.95 | |
| FSE9988NB | 34.925*50.8*7.95 TB | 1.375*2.000*0.313 TB | 34.925 | 50.8 | | 7.95 | |
| FSE9954NB | 34.93*50.8*7.95 SM | | 34.93 | 50.8 | | 7.95 | |
| FSE9888FB | 34.93*50.8*7.95 TB(VITON) | VITON | 34.93 | 50.8 | | 7.95 | |
| FSE0634NB | 34.93*50.8*7.95 TC | | 34.93 | 50.8 | | 7.95 | |
| FSE9919NB | 34.93*50.8*9.53 TC | | 34.93 | 50.8 | | 9.53 | |
| FSE1101NB | 36.5*50.8*7.9 TCV(NBR80) | AP2183F,WLK | 36.5 | 50.8 | | 7.9 | |
| FSE9882NB | 36.5*50.8*7.9 TZY(NBR80) | AP2183E,WLK | 36.5 | 50.8 | | 7.9 | |
| FSE9874NB | 36.5*50.8*7.95/8.74 TCV | | 36.5 | 50.8 | | 7.95 | 8.74 |
| FSE9942NB | 36.53*50.8*7.95 TC | | 36.53 | 50.8 | | 7.95 | |
| FSE9883NB | 36.53*50.8*7.95 TCV | NBR80 | 36.53 | 50.8 | | 7.95 | |
| FSE0088NB | 38.1*50.8*6.3 TC | 1.500*2.000*0.248 TC | 38.1 | 50.8 | | 6.3 | |
| FSE0088N0 | 38.1*50.8*6.3 TC w/o Spring | | 38.1 | 50.8 | | 6.3 | |
| FSE9931NB | 38.1*50.8*6.35 TB | | 38.1 | 50.8 | | 6.35 | |
| FSE9961NB | 38.1*50.8*6.35 TC | | 38.1 | 50.8 | | 6.35 | |
| FSE9961FB | 38.1*50.8*6.35 TC(VITON) | | 38.1 | 50.8 | | 6.35 | |
| FSD9989NB | 38.1*50.8*7.9 TC | 1.500*2.000*0.310 TC | 38.1 | 50.8 | | 7.9 | |
| FSD0363NB | 38.1*50.8*7.92 TB | 1.500*2.000*0.312 TB | 38.1 | 50.8 | | 7.92 | |
| FSE9907NB | 38.1*50.8*7.95 SBP Green Painting | | 38.1 | 50.8 | | 7.95 | |
| FSE9960NB | 38.1*50.8*7.95 TA | | 38.1 | 50.8 | | 7.95 | |
| FSE0194NB | 38.1*50.8*7.95 TB | 1.500*2.000*0.313 TB | 38.1 | 50.8 | | 7.95 | |
| FSE9986NB | 38.1*50.8*7.95 TC | 1.500*2.000*0.313 TC | 38.1 | 50.8 | | 7.95 | |
| FSE9932NB | 41.28*50.8*6.35 SC | | 41.28 | 50.8 | | 6.35 | |
| FSE9950FB | 41.28*50.8*6.35 TB(FKM) | VITON | 41.28 | 50.8 | | 6.35 | |
| FSE0264NB | 31.7*50.9*11 TC | 1.250*2.000*0.430 TC | 31.7 | 50.9 | | 11 | |
| FSE0262NB | 35*50.9*12.7 SC C106 | 1.375*2.000*0.500 SC | 35 | 50.9 | | 12.7 | |
| FSE0752NB | 25*51*8 TC | | 25 | 51 | | 8 | |
| FSE0708NB | 30*51*6 SB | | 30 | 51 | | 6 | |
| FSE0346NB | 30*51*10 TC | | 30 | 51 | | 10 | |
| FSE0348NB | 31*51*7 TC | | 31 | 51 | | 7 | |
| FSE0687NB | 32*51*6 TZ | | 32 | 51 | | 6 | |
| FSE0605NB | 32*51*8 SC | | 32 | 51 | | 8 | |
| FSE0676NB | 32*51*9.5 TC | | 32 | 51 | | 9.5 | |
| FSE0491NB | 35*51*9 TC | | 35 | 51 | | 9 | |
| FSE0665NB | 35*51*9 TCV(NBR80shore) | | 35 | 51 | | 9 | |
| FSE0403NB | 35*51*10 TC | | 35 | 51 | | 10 | |
| FSE0589NB | 35*51*12 TC | | 35 | 51 | | 12 | |
| FSE0753NB | 36*51*8 TC | | 36 | 51 | | 8 | |
| FSE0844NB | 37*51*8 TB | | 37 | 51 | | 8 | |
| FSE0062NB | 38*51*7 SC | | 38 | 51 | | 7 | |
| FSE0769NB | 38*51*7 TC | | 38 | 51 | | 7 | |
| FSE0182NB | 38*51*8 TC | | 38 | 51 | | 8 | |

| WLK CODE | OIL SEALS | DESCRIPTION | ID | OD1 | OD2 | H1 | H2 |
|-----------|----------------------|--------------------------|----|-----|-----|-----|------|
| FSE0517NB | 38*51/58*13/15 TB5L | KIA USED M502 17 335A | 38 | 51 | 58 | 13 | 15 |
| FSE0616NB | 39*51*7.5 TC3(BROWN) | 43252-M0200 | 39 | 51 | | 7.5 | |
| FSE0848NB | 40*51*6 TC | | 40 | 51 | | 6 | |
| FSE0850NB | 41*51*5 KC | | 41 | 51 | | 5 | |
| FSE0994NB | 41*51*6 SC | | 41 | 51 | | 6 | |
| FSE0386NB | 42*51*7 TC | | 42 | 51 | | 7 | |
| FSE1095NB | 19*52*8 TC | | 19 | 52 | | 8 | |
| FSE0061NB | 20*52*7 TC | | 20 | 52 | | 7 | |
| FSE0060NB | 20*52*8 TC | G40/42 | 20 | 52 | | 8 | |
| FSE0059NB | 20*52*9 TC | | 20 | 52 | | 9 | |
| FSE0058NB | 20*52*10 TC | | 20 | 52 | | 10 | |
| FSE0573N0 | 20*52*10/12 KCY | | 20 | 52 | | 10 | 12 |
| FSE0544NB | 22*52*7 TC | | 22 | 52 | | 7 | |
| FSE0908NB | 22*52*8 TC | | 22 | 52 | | 8 | |
| FSE0267NB | 22*52*10 TC | | 22 | 52 | | 10 | |
| FSE0603NB | 24*52*7 TC | | 24 | 52 | | 7 | |
| FSE0603FB | 24*52*7 TC(VITON) | | 24 | 52 | | 7 | |
| FSE0399NB | 24*52*10 SC | | 24 | 52 | | 10 | |
| FSE0398NB | 24*52*10 TC | | 24 | 52 | | 10 | |
| FSE0057NB | 25*52*6 TC | | 25 | 52 | | 6 | |
| FSE0973NB | 25*52*7 SC | 5119 | 25 | 52 | | 7 | |
| FSE0973FB | 25*52*7 SC(VITON) | | 25 | 52 | | 7 | |
| FSE0056NB | 25*52*7 TC | | 25 | 52 | | 7 | |
| FSE0056FB | 25*52*7 TC(FKM)VITON | | 25 | 52 | | 7 | |
| FSE1092NB | 25*52*7/7.5 TCV | | 25 | 52 | | 7 | 7.5 |
| FSE0823NB | 25*52*8 DC | | 25 | 52 | | 8 | |
| FSE0110NB | 25*52*8 TC | | 25 | 52 | | 8 | |
| FSE0110QB | 25*52*8 TC(VMQ) | | 25 | 52 | | 8 | |
| FSE0680NB | 25*52*8/11.5 TG9Y | Tricity Bendix, Zanussi, | 25 | 52 | | 8 | 11.5 |
| FSE0694NB | 25*52/103*8/24 TG5Y | 03AT89 | 25 | 52 | 103 | 8 | 24 |
| FSE0940NB | 25*52*10 SC | 5155 | 25 | 52 | | 10 | |
| FSE0268NB | 25*52*10 TC | | 25 | 52 | | 10 | |
| FSE0268FB | 25*52*10 TC(VITON) | | 25 | 52 | | 10 | |
| FSE0092NB | 25*52*10 TC6(TC6Y) | | 25 | 52 | | 10 | |
| FSE0327N0 | 25*52*10/12 KC | | 25 | 52 | | 10 | 12 |
| FSE0111NB | 25*52*11 TC | | 25 | 52 | | 11 | |
| FSE0697QB | 25*52*12 TC(VMQ) | | 25 | 52 | | 12 | |
| FSE0055NB | 25*52*12 TC6(TCU) | | 25 | 52 | | 12 | |
| FSE0054NB | 25*52/64*12 TC6Y | | 25 | 52 | 64 | 12 | |
| FSE0829NB | 26*52*7 TC | | 26 | 52 | | 7 | |
| FSE0101NB | 26*52*7/8 TCY | 09283-26007 | 26 | 52 | | 7 | 8 |
| FSE0053NB | 26*52*7/9 TCY | | 26 | 52 | | 7 | 9 |
| FSE0890NB | 26*52*8 SC | | 26 | 52 | | 8 | |
| FSE0883NB | 26*52*8 TC | | 26 | 52 | | 8 | |
| FSE0112NB | 26*52*9 TC | | 26 | 52 | | 9 | |
| FSE0897NB | 26*52*10 TC | | 26 | 52 | | 10 | |
| FSE0696NB | 27*52*8 SB | | 27 | 52 | | 8 | |
| FSE0644NB | 27*52*8 SC | | 27 | 52 | | 8 | |
| FSE0051NB | 28*52*6 SC | | 28 | 52 | | 6 | |
| FSE0497NB | 28*52*7 SC | | 28 | 52 | | 7 | |
| FSE0497FB | 28*52*7 SC(VITON) | | 28 | 52 | | 7 | |
| FSE0271NB | 28*52*7 TC | 113LG16 | 28 | 52 | | 7 | |
| FSE0525NB | 28*52*8 TC | | 28 | 52 | | 8 | |
| FSE0636NB | 28*52*9/11.5 TC49Y | 124097 | 28 | 52 | | 9 | 11.5 |
| FSE0114NB | 28*52*10 TC | 113LG70 | 28 | 52 | | 10 | |
| FSE0413NB | 28*52*12 SC | | 28 | 52 | | 12 | |
| FSE0910NB | 29*52*7 TC | | 29 | 52 | | 7 | |

| WLK CODE | OIL SEALS | DESCRIPTION | ID | OD1 | OD2 | H1 | H2 |
|-----------|------------------------------------|--------------------------|----|-----|-----|-----|------|
| FSE0050NB | 30*52*5 SC | | 30 | 52 | | 5 | |
| FSE0969NB | 30*52*6 TC | | 30 | 52 | | 6 | |
| FSE0123NB | 30*52*7 HTBR | | 30 | 52 | | 7 | |
| FSE0412NB | 30*52*7 SB | | 30 | 52 | | 7 | |
| FSE0122FB | 30*52*7 SC(VITON) | TC修掉副唇 | 30 | 52 | | 7 | |
| FSE0124NB | 30*52*7 TC | 8067-30031/32 | 30 | 52 | | 7 | |
| FSE0124FB | 30*52*7 TC(VITON) | | 30 | 52 | | 7 | |
| FSE0124QB | 30*52*7 TC(VMQ) | | 30 | 52 | | 7 | |
| FSE0670NB | 30*52/65*7/10 TG65Y | INDESIT, Ariston | 30 | 52 | 65 | 7 | 10 |
| FSE0125NB | 30*52*8 HTBR | 27431-70B00 | 30 | 52 | | 8 | |
| FSE0049NB | 30*52*8 TC | | 30 | 52 | | 8 | |
| FSE0049QB | 30*52*8 TC (VMQ) | | 30 | 52 | | 8 | |
| FSE0583NS | 30*52/62*8/12 TG5Y | 113ZN13 | 30 | 52 | 62 | 8 | 12 |
| FSE0126NB | 30*52*9 TC | | 30 | 52 | | 9 | |
| FSE0096NB | 30*52*10 SC | | 30 | 52 | | 10 | |
| FSE0096FB | 30*52*10 SC(VITON) | | 30 | 52 | | 10 | |
| FSE0093NB | 30*52*10 TC | 03AT52, 113LG18 | 30 | 52 | | 10 | |
| FSE0093QB | 30*52*10 TC (VMQ) | | 30 | 52 | | 10 | |
| FSE0093FB | 30*52*10 TC(VITON) | | 30 | 52 | | 10 | |
| FSE0127NB | 30*52*10/12 TGY(TCY) | 113LG84(4815) | 30 | 52 | | 10 | 12 |
| FSE0724NB | 30*52*11 TB | | 30 | 52 | | 11 | |
| FSE0048NB | 30*52*11 TC | | 30 | 52 | | 11 | |
| FSE0903NB | 30*52*11/12.5 TGAY | 03AT92 | 30 | 52 | | 11 | 12.5 |
| FSE0066NB | 30*52/60*11/15 TCAY(Y) | 03AT14;113CY02 | 30 | 52 | 60 | 11 | 15 |
| FSE0558NS | 30*52/66*12/16.5 TG6Y(S304 SPRING) | 03AT39, 113ZN04 | 30 | 52 | 66 | 12 | 16.5 |
| FSE0552NB | 31*52*7 SC | 113LG22 | 31 | 52 | | 7 | |
| FSE0349NB | 31*52*7 TC | Whirlpool, Universal | 31 | 52 | | 7 | |
| FSE0581NB | 31*52*8 SC | | 31 | 52 | | 8 | |
| FSE0143N0 | 32*52*5 VC | | 32 | 52 | | 5 | |
| FSE0898NB | 32*52*6.5 TC | | 32 | 52 | | 6.5 | |
| FSE0974FB | 32*52*7 SC(VITON) | | 32 | 52 | | 7 | |
| FSE0102NB | 32*52*7 TC | 113LG23 | 32 | 52 | | 7 | |
| FSE0102QB | 32*52*7 TC (VMQ) | | 32 | 52 | | 7 | |
| FSE0102FB | 32*52*7 TC(VITON) | | 32 | 52 | | 7 | |
| FSE1080NB | 32*52*8 HTCR(BROWN) | | 32 | 52 | | 8 | |
| FSE0559NB | 32*52*8 TB | | 32 | 52 | | 8 | |
| FSE0500NB | 32*52*8 TC | 90043-11086 | 32 | 52 | | 8 | |
| FSE0500FB | 32*52*8 TC(VITON) | | 32 | 52 | | 8 | |
| FSE0598NB | 32*52/78*8/14.8 TG5Y | 一開始開模, 就採無商標 | 32 | 52 | 78 | 8 | 14.8 |
| FSE0073NB | 32*52*9 TC | | 32 | 52 | | 9 | |
| FSE0819NB | 32*52*9.5 KB | | 32 | 52 | | 9.5 | |
| FSE0047NB | 32*52*10 HTC4L | 09283-32009 | 32 | 52 | | 10 | |
| FSE0104NB | 32*52*10 TC | | 32 | 52 | | 10 | |
| FSE0104FB | 32*52*10 TC(VITON) | | 32 | 52 | | 10 | |
| FSE0326NB | 32*52*11 HTCL | 90311-32086,NJ606 | 32 | 52 | | 11 | |
| FSE0141NB | 32*52*11 TC | 90311-32010, 90311-32074 | 32 | 52 | | 11 | |
| FSE0141NS | 32*52*11 TC(S304 SPRING) | SUS304 SPRING | 32 | 52 | | 11 | |
| FSE0731NB | 32*52*11/15.5 TC9 | 38342-21000 | 32 | 52 | | 11 | 15.5 |
| FSE0046NB | 32*52*12 TC | | 32 | 52 | | 12 | |
| FSE0401NB | 33*52*6 TC | | 33 | 52 | | 6 | |
| FSE0501NB | 33*52*7 TC | | 33 | 52 | | 7 | |
| FSE0712NB | 33*52*8 TC | | 33 | 52 | | 8 | |
| FSE0318NB | 33*52*10 TC | | 33 | 52 | | 10 | |
| FSE0925NB | 34*52*7 SB | | 34 | 52 | | 7 | |
| FSE0380NB | 34*52*7 SEB(SM) | | 34 | 52 | | 7 | |
| FSE0912NB | 34*52*7 TC | | 34 | 52 | | 7 | |
| FSE0912FB | 34*52*7 TC(VITON) | | 34 | 52 | | 7 | |

| WLK CODE | OIL SEALS | DESCRIPTION | ID | OD1 | OD2 | H1 | H2 |
|-----------|-------------------------------|--------------------------|----|-----|-----|------|----|
| FSE0913NB | 34*52*7.5 TC | | 34 | 52 | | 7.5 | |
| FSE0606NB | 34*52*8 SC | | 34 | 52 | | 8 | |
| FSE0144NB | 34*52*8 TC | | 34 | 52 | | 8 | |
| FSE0145NB | 34*52*9 TC | | 34 | 52 | | 9 | |
| FSE0622NB | 34*52*10 TC | | 34 | 52 | | 10 | |
| FSE0575NB | 34*52*11 TC | | 34 | 52 | | 11 | |
| FSE0751NB | 35*52*5 TC | | 35 | 52 | | 5 | |
| FSE0538NB | 35*52*6 TB | | 35 | 52 | | 6 | |
| FSE0988NB | 35*52*6 TC | | 35 | 52 | | 6 | |
| FSE0988FB | 35*52*6 TC(VITON) | | 35 | 52 | | 6 | |
| FSE0513NB | 35*52*6.5 TB | | 35 | 52 | | 6.5 | |
| FSE1087FB | 35*52*7 SC(VITON) | | 35 | 52 | | 7 | |
| FSE0107NB | 35*52*7 TC | 113LG144 | 35 | 52 | | 7 | |
| FSE0107FS | 35*52*7 TC (FKM)S304 | VITON+S304 SPRING | 35 | 52 | | 7 | |
| FSE0107FB | 35*52*7 TC (FKM)VITON | | 35 | 52 | | 7 | |
| FSE0107QB | 35*52*7 TC (VMQ) | | 35 | 52 | | 7 | |
| FSE0596NB | 35*52*7 TCV(NBR Blue 80) | | 35 | 52 | | 7 | |
| FSE0872NB | 35*52*8 TB | | 35 | 52 | | 8 | |
| FSE0086NB | 35*52*8 TC | 農機用 | 35 | 52 | | 8 | |
| FSE0086FB | 35*52*8 TC(VITON) | | 35 | 52 | | 8 | |
| FSE0620NB | 35*52/65*8/10 TGA5(Y) | Ariston, Merloni, Indesi | 35 | 52 | 65 | 8 | 10 |
| FSE0045NB | 35*52*9 SC6Y | NM55 曲軸 GJ 2068E | 35 | 52 | | 9 | |
| FSE0592NB | 35*52*9 TB | | 35 | 52 | | 9 | |
| FSE0044NB | 35*52*9 TC | KND3 曲軸 | 35 | 52 | | 9 | |
| FSE0044FB | 35*52*9 TC(VITON) | | 35 | 52 | | 9 | |
| FSE0667NB | 35*52*9 TCV(NBR80) | | 35 | 52 | | 9 | |
| FSE0824NB | 35*52*10 DC | | 35 | 52 | | 10 | |
| FSE0531NB | 35*52*10 SC | | 35 | 52 | | 10 | |
| FSE0155NB | 35*52*10 TC | 09283-35020 | 35 | 52 | | 10 | |
| FSE0608NB | 35*52*11 TC | | 35 | 52 | | 11 | |
| FSE0043NB | 35*52*11 TC4 | | 35 | 52 | | 11 | |
| FSE0041NB | 35*52/64*11/12 TC65Y | AE2074E | 35 | 52 | 64 | 11 | 12 |
| FSE0156NB | 35*52*11.8 DC | | 35 | 52 | | 11.8 | |
| FSE0621NB | 35*52*12 DC NBR85 Shore | INDESIT used | 35 | 52 | | 12 | |
| FSE0042NB | 35*52*12 TC6 | | 35 | 52 | | 12 | |
| FSE0042QB | 35*52*12 TC6 (VMQ) | | 35 | 52 | | 12 | |
| FSE0965NB | 35*52*16 TCAFY(Blue +sponge) | 9968020 | 35 | 52 | | 16 | |
| FSE0985FB | 36*52*7 SC(VITON) | | 36 | 52 | | 7 | |
| FSE0321NB | 36*52*7 TC | | 36 | 52 | | 7 | |
| FSE0321FB | 36*52*7 TC(VITON) | | 36 | 52 | | 7 | |
| FSE0825NB | 36*52*8 DC | | 36 | 52 | | 8 | |
| FSE0776NB | 36*52*8 TC | | 36 | 52 | | 8 | |
| FSE0335NB | 36*52*10 HTCL | MD-703743;MD-712012 | 36 | 52 | | 10 | |
| FSE0802NB | 36*52*10 TC | | 36 | 52 | | 10 | |
| FSE0328NB | 36*52*11 TC | | 36 | 52 | | 11 | |
| FSE0097NB | 36*52*15 TC6(TCU) | | 36 | 52 | | 15 | |
| FSE0747NB | 37*52*7 TC | | 37 | 52 | | 7 | |
| FSE0894NB | 37*52*8 SC | | 37 | 52 | | 8 | |
| FSE0794NB | 37*52*8 TC | | 37 | 52 | | 8 | |
| FSE0148NB | 37*52*9 TC | | 37 | 52 | | 9 | |
| FSE0795NB | 37*52*10 TC | | 37 | 52 | | 10 | |
| FSE0980NB | 37*52*14.5 Y | | 37 | 52 | | 14.5 | |
| FSE0720NB | 38*52*6 HTCR | AH2221E | 38 | 52 | | 6 | |
| FSE0773N0 | 38*52*6 KB | | 38 | 52 | | 6 | |
| FSE0389NB | 38*52*6 TB(TM) | MA-125844 | 38 | 52 | | 6 | |
| FSE0509NB | 38*52*6 TC | | 38 | 52 | | 6 | |
| FSE0733NB | 38*52*6/14 TC9 | | 38 | 52 | | 6 | 14 |

| WLK CODE | OIL SEALS | DESCRIPTION | ID | OD1 | OD2 | H1 | H2 |
|-----------|--------------------------|-------------------------|------|-----|------|------|------|
| FSE0699NB | 38*52*7 HTCR | 90043-11210 | 38 | 52 | | 7 | |
| FSE0896NB | 38*52*7 SB | | 38 | 52 | | 7 | |
| FSE0183NB | 38*52*7 SC | | 38 | 52 | | 7 | |
| FSE0183FB | 38*52*7 SC(VITON) | TC副唇修掉 | 38 | 52 | | 7 | |
| FSE0482NB | 38*52*7 TA2 | 90311-38037 | 38 | 52 | | 7 | |
| FSE0388NB | 38*52*7 TC | | 38 | 52 | | 7 | |
| FSE0388FB | 38*52*7 TC(VITON) | | 38 | 52 | | 7 | |
| FSE0734NB | 38*52*7/12 TB9 | | 38 | 52 | | 7 | 12 |
| FSE0184NB | 38*52*8 TC | | 38 | 52 | | 8 | |
| FSE0184QB | 38*52*8 TC(VMQ) | | 38 | 52 | | 8 | |
| FSE0081NB | 38*52*9 SC | | 38 | 52 | | 9 | |
| FSE0040NB | 38*52*9 TC | 久保 17/20H 耕耘小油封 | 38 | 52 | | 9 | |
| FSE0040FB | 38*52*9 TC(VITON) | | 38 | 52 | | 9 | |
| FSE0382NB | 38*52*9.5 VC | 40232-18000 | 38 | 52 | | 9.5 | |
| FSE0291NB | 38*52*10 TC | | 38 | 52 | | 10 | |
| FSE0618NB | 39*52*6 KB2 | | 39 | 52 | | 6 | |
| FSE0344NB | 39*52*6/11.5 TB9 (TZ9) | MB-242822 | 39 | 52 | | 6 | 11.5 |
| FSD0517NB | 39*52*6.35/11.5 TB9 | | 39 | 52 | | 6.35 | 11.5 |
| FSE0723NB | 39*52*6.5 KB2 | 52713-28000 | 39 | 52 | | 6.5 | |
| FSE0920NB | 39*52*7 SB | | 39 | 52 | | 7 | |
| FSE0728NB | 39*52*7 TB | | 39 | 52 | | 7 | |
| FSE0197NB | 39*52*7 TC | | 39 | 52 | | 7 | |
| FSE0959NB | 39*52*9/10 TC | | 39 | 52 | | 9 | 10 |
| FSE0655NB | 39*52*11 DC | | 39 | 52 | | 11 | |
| FSE0039NB | 39*52*11 TC4 | | 39 | 52 | | 11 | |
| FSE0511NB | 39.5*52*10/11 TC4Y | MD-731708 | 39.5 | 52 | | 10 | 11 |
| FSE0563NB | 39.6*52*10/11 HTC9R | | 39.6 | 52 | | 10 | 11 |
| FSE0537NB | 39.6*52*10/11 TC9 | | 39.6 | 52 | | 10 | 11 |
| FSE0562NB | 40*52*5 SC | | 40 | 52 | | 5 | |
| FSE1111NB | 40*52*5 TC | | 40 | 52 | | 5 | |
| FSE0181N0 | 40*52*5 VB | | 40 | 52 | | 5 | |
| FSE0119N0 | 40*52*5 VC | | 40 | 52 | | 5 | |
| FSE0556NB | 40*52*6 HTCR | 8-94251-1710 | 40 | 52 | | 6 | |
| FSE0653NB | 40*52*6 SC | | 40 | 52 | | 6 | |
| FSE0880NB | 40*52*6 TC | | 40 | 52 | | 6 | |
| FSE0484NB | 40*52*6/10 TBY(TB5Y) | 43232-50A00 | 40 | 52 | | 6 | 10 |
| FSE0921NB | 40*52*6/6.5 TCV(NBR) | NBR80 | 40 | 52 | | 6 | 6.5 |
| FSE0878NB | 40*52*7 HTCAL | AH2342G | 40 | 52 | | 7 | |
| FSE0385NB | 40*52*7 HTCR | 13042-42L00,NJ765 | 40 | 52 | | 7 | |
| FSE0385AB | 40*52*7 HTCR(ACM) | | 40 | 52 | | 7 | |
| FSE0385FB | 40*52*7 HTCR(VITON)FKM | | 40 | 52 | | 7 | |
| FSE0385QB | 40*52*7 HTCR(VMQ) | AH2342F | 40 | 52 | | 7 | |
| FSE0668QB | 40*52*7 HTGL(VMQ) | | 40 | 52 | | 7 | |
| FSE0202FB | 40*52*7 SC (FKM)VITON | | 40 | 52 | | 7 | |
| FSE0202NS | 40*52*7 SC(S304 SPRING) | | 40 | 52 | | 7 | |
| FSE0202QB | 40*52*7 SC(VMQ) | | 40 | 52 | | 7 | |
| FSE0971NB | 40*52*7 SG(VITON) | | 40 | 52 | | 7 | |
| FSE0203NB | 40*52*7 TA | 90043-11206;90311-40108 | 40 | 52 | | 7 | |
| FSE0469NB | 40*52*7 TB | 90311-40108 | 40 | 52 | | 7 | |
| FSE0095NB | 40*52*7 TC | | 40 | 52 | | 7 | |
| FSE0095QB | 40*52*7 TC (VMQ) | | 40 | 52 | | 7 | |
| FSE0095FB | 40*52*7 TC(VITON)FKM | | 40 | 52 | | 7 | |
| FSE0553NB | 40*52/58*7.5 HTC5 Black | 357501641B | 40 | 52 | 58 | 7.5 | |
| FSE0934NB | 40*52/58*7.6 TG35(Brown) | | 40 | 52 | 58 | 7.6 | |
| FSE0936NB | 40*52*8 TB | | 40 | 52 | | 8 | |
| FSE0037NB | 40*52*8 TC | NM65 曲軸 | 40 | 52 | | 8 | |
| FSE0038NB | 40*52/57.6*8 TG35Y | 40*52*8 STC | 40 | 52 | 57.6 | 8 | |

| WLK CODE | OIL SEALS | DESCRIPTION | ID | OD1 | OD2 | H1 | H2 |
|-----------|----------------------------------|------------------------|--------|--------|------|-------|----|
| FSE0599NB | 40*52/62*8.5/7 TG5(TC5) | 3461793 | 40 | 52 | 62 | 8.5 | 7 |
| FSE0299NB | 40*52*10 TC | | 40 | 52 | | 10 | |
| FSE0765NB | 40*52/58.5*10 TBJ(Y) | | 40 | 52 | 58.5 | 10 | |
| FSE0851NB | 41*52*7 TC | | 41 | 52 | | 7 | |
| FSE0989NB | 41*52*8 SC | | 41 | 52 | | 8 | |
| FSE0216NB | 42*52*4 TC | 174313 | 42 | 52 | | 4 | |
| FSE0868NB | 42*52*5 TC | | 42 | 52 | | 5 | |
| FSE0306NB | 42*52*7 TC | | 42 | 52 | | 7 | |
| FSE0893NB | 42*52*7/10 GA | | 42 | 52 | | 7 | 10 |
| FSE0649NB | 42*52*8 TC | | 42 | 52 | | 8 | |
| FSE0899NB | 42*52*9 TC | | 42 | 52 | | 9 | |
| FSE0342NB | 45*52*4 VB | | 45 | 52 | | 4 | |
| FSE0472NB | 45*52*4 VG | | 45 | 52 | | 4 | |
| FSE0200N0 | 45*52*4.5 VG(blue) | 外徑有紋路 | 45 | 52 | | 4.5 | |
| FSE0675NB | 45*52*5 TC | | 45 | 52 | | 5 | |
| FSE0635NB | 45*52*7 TC | | 45 | 52 | | 7 | |
| FSE0551NB | 45*52*8 SC | | 45 | 52 | | 8 | |
| FSE0805NB | 45*52*8 TC | | 45 | 52 | | 8 | |
| FSE0036NB | 33.38*52.38*10.31 HSC | 1.314*2.062*0.406 HSC | 33.38 | 52.38 | | 10.31 | |
| FSE9940NB | 33.34*52.39*11.11 SB(SM) | URB,E1013 | 33.34 | 52.39 | | 11.11 | |
| FSE9993NB | 36.52*52.39*7.9 TB Blue Painting | 1.437*2.062*0.311 TB | 36.52 | 52.39 | | 7.9 | |
| FSE9880NB | 28.58*52.4*9.53 SC | | 28.58 | 52.4 | | 9.53 | |
| FSE9886NB | 28.58*52.4*11.51 TB | | 28.58 | 52.4 | | 11.51 | |
| FSE9927NB | 30.18*52.4*6.35 SB | | 30.18 | 52.4 | | 6.35 | |
| FSE9985NB | 31.75*52.4*6.35 TB | 1.250*2.063*0.250 TB | 31.75 | 52.4 | | 6.35 | |
| FSE9870NB | 31.75*52.4*9.53 TB | | 31.75 | 52.4 | | 9.53 | |
| FSE0034QB | 36.5*52.4*12.7 HTCL(VMQ) | (VMQ) | 36.5 | 52.4 | | 12.7 | |
| FSE0034NB | 36.5*52.4*12.7 HTCR(VMQ) | 1.437*2.063*0.500 HTCR | 36.5 | 52.4 | | 12.7 | |
| FSE9929NB | 36.53*52.4*7.95 TC | | 36.53 | 52.4 | | 7.95 | |
| FSE9867NB | 36.53*52.4*12.7 TC | | 36.53 | 52.4 | | 12.7 | |
| FSE9917NB | 37.31*52.4*7.95 TC | | 37.31 | 52.4 | | 7.95 | |
| FSE9957NB | 38.1*52.4*6.35 TB | | 38.1 | 52.4 | | 6.35 | |
| FSE9911NB | 38.1*52.4*6.35 TC | | 38.1 | 52.4 | | 6.35 | |
| FSE9922NB | 38.1*52.4*7.95 TC | | 38.1 | 52.4 | | 7.95 | |
| FSE9871NB | 38.1*52.4*9.53 SC | | 38.1 | 52.4 | | 9.53 | |
| FSE9956NB | 39.7*52.4*6.35 TB | | 39.7 | 52.4 | | 6.35 | |
| FSE9890NB | 40.5*52.5*6.5 HTCR Brown | 90311-40020 | 40.5 | 52.5 | | 6.5 | |
| FSE9999NB | 28.575*52.705*9.525 SC | 1.125*2.075*0.375 SC | 28.575 | 52.705 | | 9.525 | |
| FSE0519NB | 27*53*7 TC | | 27 | 53 | | 7 | |
| FSE0895NB | 30*53*8 TC | | 30 | 53 | | 8 | |
| FSF0131NB | 30*53/60*10/13 TCAY(Y) | CANDY, UNIVERSAL | 30 | 53 | 60 | 10 | 13 |
| FSE0877NB | 30*53/63*10.5/16 TG59Y | WLK商標 | 30 | 53 | 63 | 10.5 | 16 |
| FSD0487NB | 32*53*7 HTCR | 90311-32012 | 32 | 53 | | 7 | |
| FSE0886NB | 34*53*8 HTCR | | 34 | 53 | | 8 | |
| FSE0409NB | 34*53*9 TC | (BROWN) | 34 | 53 | | 9 | |
| FSE1088NB | 35*53*7 TC | | 35 | 53 | | 7 | |
| FSE0516NB | 35*53*8 SC | | 35 | 53 | | 8 | |
| FSE0887NB | 35*53*12 TZ | | 35 | 53 | | 12 | |
| FSE0521NB | 36*53*9 TC | | 36 | 53 | | 9 | |
| FSE0845NB | 37*53*7 TC | | 37 | 53 | | 7 | |
| FSE0185NB | 38*53*8 HTCR | | 38 | 53 | | 8 | |
| FSE0627NB | 38*53*8 TC | | 38 | 53 | | 8 | |
| FSE0615NB | 38.5*53*8 HTCR | 80673-8100 | 38.5 | 53 | | 8 | |
| FSE0035NB | 40*53*7 TB | | 40 | 53 | | 7 | |
| FSE0677NB | 40*53*7 TC | | 40 | 53 | | 7 | |
| FSE0804NB | 40*53*8 TC | | 40 | 53 | | 8 | |
| FSE1089NB | 40*53/72*12/25 Y | | 40 | 53 | 72 | 12 | 25 |

| WLK CODE | OIL SEALS | DESCRIPTION | ID | OD1 | OD2 | H1 | H2 |
|-----------|------------------------------------|-----------------------|--------|--------|-----|-------|-----|
| FSE0540NB | 40*53/72*12/30 TB5Y(Y) | M50517335, KIA車用 | 40 | 53 | 72 | 12 | 30 |
| FSE0666NB | 41*53*6 HTCR(BROWN) | BH6382E | 41 | 53 | | 6 | |
| FSE0211NB | 41*53*7 TA | 90311-41123 | 41 | 53 | | 7 | |
| FSE0729NB | 41*53*7 TB | | 41 | 53 | | 7 | |
| FSE0502NB | 41*53*7 TC | | 41 | 53 | | 7 | |
| FSE0946NB | 41*53*8 DC | | 41 | 53 | | 8 | |
| FSE0117N0 | 41*53*8 軟 | 并關前輪軟 | 41 | 53 | | 8 | |
| FSE0658NB | 41*53*8/9.5 TC4 | | 41 | 53 | | 8 | 9.5 |
| FSE0212NB | 41*53*10.5 TC | | 41 | 53 | | 10.5 | |
| FSE0911NB | 41*53*10.5 TC4 | | 41 | 53 | | 10.5 | |
| FSE0706NB | 42*53*7 TC | | 42 | 53 | | 7 | |
| FSE0717NB | 42*53*8 TZ | | 42 | 53 | | 8 | |
| FSE0853NB | 43*53*4 VC | | 43 | 53 | | 4 | |
| FSE0566NB | 45*53*6.5/8 SB | | 45 | 53 | | 6.5 | 8 |
| FSE0857NB | 45*53*8 TC | | 45 | 53 | | 8 | |
| FSE0945NB | 25*53.5*10/13 TCY | | 25 | 53.5 | | 10 | 13 |
| FSE0128NB | 30*53.5*10/14 TC | 特殊要求作 | 30 | 53.5 | | 10 | 14 |
| FSE0129NB | 30*53.5*10/14 TCY(9.5/13) | 113LG19義大利專用 | 30 | 53.5 | | 10 | 14 |
| FSE9965NB | 28.58*53.97*6.35 SC | | 28.58 | 53.97 | | 6.35 | |
| FSE9876NB | 31.75*53.97*6.35 TC | | 31.75 | 53.97 | | 6.35 | |
| FSE9876FB | 31.75*53.97*6.35 TC(FKM) | | 31.75 | 53.97 | | 6.35 | |
| FSE9937NB | 31.75*53.97*7.95 SB | | 31.75 | 53.97 | | 7.95 | |
| FSE9875NB | 31.75*53.97*7.95 TC | | 31.75 | 53.97 | | 7.95 | |
| FSE9877NB | 31.75*53.97*9.53 TC | | 31.75 | 53.97 | | 9.53 | |
| FSE9955NB | 34.92*53.97*7.95 TM | | 34.92 | 53.97 | | 7.95 | |
| FSE9938NB | 34.92*53.97*9.52 TC | | 34.92 | 53.97 | | 9.52 | |
| FSE9924NB | 39.7*53.97*7.95 SC | | 39.7 | 53.97 | | 7.95 | |
| FSE9953NB | 41.28*53.97*6.35 TC | | 41.28 | 53.97 | | 6.35 | |
| FSE9984NB | 34.925*53.975*7.95 SA | 1.375*2.125*0.313 SA | 34.925 | 53.975 | | 7.95 | |
| FSE9970NB | 34.93*53.98*6.35 TC | | 34.93 | 53.98 | | 6.35 | |
| FSE9971NB | 34.93*53.98*7.95 TB | | 34.93 | 53.98 | | 7.95 | |
| FSE9946NB | 34.93*53.98*7.95 TC | | 34.93 | 53.98 | | 7.95 | |
| FSE9913NB | 34.93*53.98*9.53 DC | | 34.93 | 53.98 | | 9.53 | |
| FSE9926NB | 34.93*53.98*11.13 TA | | 34.93 | 53.98 | | 11.13 | |
| FSE9952NB | 34.93*53.98*11.13 TB | | 34.93 | 53.98 | | 11.13 | |
| FSE9935NB | 34.93*53.98*11.13 TC | | 34.93 | 53.98 | | 11.13 | |
| FSE9881NB | 36.53*53.98*6.35 SC | | 36.53 | 53.98 | | 6.35 | |
| FSE9925NB | 36.53*53.98*7.95 TB | | 36.53 | 53.98 | | 7.95 | |
| FSE9891NB | 38.1*53.98*7.93 TB | | 38.1 | 53.98 | | 7.93 | |
| FSE0080NB | 38.1*53.98*7.95 SBP Green Painting | 1.500*2.125*0.313 SBP | 38.1 | 53.98 | | 7.95 | |
| FSE9968NB | 38.1*53.98*7.95 SC | | 38.1 | 53.98 | | 7.95 | |
| FSE9887NB | 38.1*53.98*7.95 TC | | 38.1 | 53.98 | | 7.95 | |
| FSE9949FB | 41.28*53.98*6.35 SB(FKM) | VITON | 41.28 | 53.98 | | 6.35 | |
| FSF9836N0 | 44.45*53.98*4.9 VB | | 44.45 | 53.98 | | 4.9 | |
| FSE0828NB | 25*54*8 TC | | 25 | 54 | | 8 | |
| FSE0832NB | 27*54*8 TC | | 27 | 54 | | 8 | |
| FSE0275NB | 30*54*7 TC | | 30 | 54 | | 7 | |
| FSE0070NB | 30*54*9 TC | | 30 | 54 | | 9 | |
| FSE0576NB | 30*54*10 TC | | 30 | 54 | | 10 | |
| FSE0624NB | 32*54*8 SC | | 32 | 54 | | 8 | |
| FSE0968NB | 32*54*8 TC | | 32 | 54 | | 8 | |
| FSE0763NB | 32*54*10 SA | | 32 | 54 | | 10 | |
| FSE0279NB | 32*54*10 TC | 0249-27-1018 | 32 | 54 | | 10 | |
| FSE0488NB | 32*54*10 TC5 | 0249-24-018 | 32 | 54 | | 10 | |
| FSE0916NB | 33*54*8 TC(BROWN) | | 33 | 54 | | 8 | |
| FSE0355NB | 33.5*54*9/15 TC9 | 90311-34007 | 33.5 | 54 | | 9 | 15 |
| FSE0351NB | 34*54*8 TC | | 34 | 54 | | 8 | |

| WLK CODE | OIL SEALS | DESCRIPTION | ID | OD1 | OD2 | H1 | H2 |
|-----------|--------------------------|-------------------------|----|-----|-----|------|------|
| FSE1006NB | 34*54*9 TC | | 34 | 54 | | 9 | |
| FSE0146NB | 34*54*9/15 TC9 | 90311-34007 | 34 | 54 | | 9 | 15 |
| FSE0542NB | 34*54*10 TC | | 34 | 54 | | 10 | |
| FSE0938NB | 34*54*11 TC | | 34 | 54 | | 11 | |
| FSE0577NB | 35*54*7 TC | | 35 | 54 | | 7 | |
| FSE0099NB | 35*54*8 HTCL | 91212-PC6-003/004,NJ311 | 35 | 54 | | 8 | |
| FSE0919NB | 35*54*8 HTZR | | 35 | 54 | | 8 | |
| FSE0539NB | 35*54*8 TB | | 35 | 54 | | 8 | |
| FSE0330NB | 35*54*8 TC | | 35 | 54 | | 8 | |
| FSE0330FB | 35*54*8 TC(VITON) | | 35 | 54 | | 8 | |
| FSE0918NB | 35*54*8 TZ | | 35 | 54 | | 8 | |
| FSE0332NB | 35*54*9 TC | | 35 | 54 | | 9 | |
| FSE0333NB | 35*54*9/15 TC9 | 90311-34007 | 35 | 54 | | 9 | 15 |
| FSE0287NB | 35*54*10 TC | | 35 | 54 | | 10 | |
| FSE0711NB | 35*54*10/17 TB9 | MD-719710 | 35 | 54 | | 10 | 17 |
| FSE0358NB | 36*54*7 TC | | 36 | 54 | | 7 | |
| FSE0170NB | 36*54*7.5 TC | 770-308-7087 | 36 | 54 | | 7.5 | |
| FSE0950NB | 36*54*7.5 TCNR | | 36 | 54 | | 7.5 | |
| FSE0678NB | 36*54*7.5 TCY | | 36 | 54 | | 7.5 | |
| FSE0948NB | 36*54*8 TC | | 36 | 54 | | 8 | |
| FSE0171NB | 36*54*10 TC | | 36 | 54 | | 10 | |
| FSE0744NB | 36*54*11 TC | | 36 | 54 | | 11 | |
| FSE0995NB | 38*54*5 TC | | 38 | 54 | | 5 | |
| FSE0847NB | 38*54*6.5 SC | | 38 | 54 | | 6.5 | |
| FSE0967FB | 38*54*7 SC(VITON) | TC修副唇(無SC模) | 38 | 54 | | 7 | |
| FSE0478NB | 38*54*7 TC | 13510-01B00 | 38 | 54 | | 7 | |
| FSE0478FB | 38*54*7 TC(VITON) | | 38 | 54 | | 7 | |
| FSE0785NB | 38*54*8 HTCR(BROWN) | | 38 | 54 | | 8 | |
| FSE0610NB | 38*54*8/11.5 HTC9L | 91205-PC8-832 | 38 | 54 | | 8 | 11.5 |
| FSE0664NB | 38*54*8/11.5 TC9 | | 38 | 54 | | 8 | 11.5 |
| FSE0186NB | 38*54*9 TC | | 38 | 54 | | 9 | |
| FSE0648NB | 38*54*9/15.5 HTC9R Brown | BH6044E | 38 | 54 | | 9 | 15.5 |
| FSE0292NB | 38*54*10 TC | | 38 | 54 | | 10 | |
| FSE0954NB | 38*54*11 TB | | 38 | 54 | | 11 | |
| FSE0932NB | 38*54*12.5/27.5 HTG9L | 14234 | 38 | 54 | | 12.5 | 27.5 |
| FSE0483NB | 39*54*6 KB2 | 52713-24000 | 39 | 54 | | 6 | |
| FSE0204NB | 40*54*5 TB(TZ) | 0398-33-065 | 40 | 54 | | 5 | |
| FSE0564NB | 40*54*5 TC | | 40 | 54 | | 5 | |
| FSE0885NB | 40*54*5 VB | | 40 | 54 | | 5 | |
| FSE0822NB | 40*54*5.5 TB | | 40 | 54 | | 5.5 | |
| FSE0781NB | 40*54*5.5 TC | | 40 | 54 | | 5.5 | |
| FSE0489NB | 40*54*6 TB | | 40 | 54 | | 6 | |
| FSE0118N0 | 40*54*7 OVC | | 40 | 54 | | 7 | |
| FSE0082NB | 40*54*7 TB | B-001-26-154 | 40 | 54 | | 7 | |
| FSE0359NB | 40*54*7 TC | | 40 | 54 | | 7 | |
| FSE0467NB | 40*54*8 TB | | 40 | 54 | | 8 | |
| FSE0475NB | 40*54*8 TC | | 40 | 54 | | 8 | |
| FSE0692NB | 40*54*10 DC(BROWN) | | 40 | 54 | | 10 | |
| FSE0691NB | 40*54*10 TC | | 40 | 54 | | 10 | |
| FSE0926NB | 40*54*11 DC | | 40 | 54 | | 11 | |
| FSE0783NB | 41*54*11 DC | | 41 | 54 | | 11 | |
| FSE1086NB | 42*54*6 TC | | 42 | 54 | | 6 | |
| FSE0852NB | 42*54*7 TC | | 42 | 54 | | 7 | |
| FSE0957NB | 42*54*7 TZ | | 42 | 54 | | 7 | |
| FSE0494NB | 42*54*7.5 TB | | 42 | 54 | | 7.5 | |
| FSE0584NB | 42*54*8 TB | 43252-M7000/01 | 42 | 54 | | 8 | |
| FSE0922NB | 42*54*10 TC | | 42 | 54 | | 10 | |

| WLK CODE | OIL SEALS | DESCRIPTION | ID | OD1 | OD2 | H1 | H2 |
|-----------|--------------------------------|--------------------|-------|-------|-----|------|-------|
| FSE0033NB | 43*54*5 SC | | 43 | 54 | | 5 | |
| FSE0736NB | 43*54*6 TA | | 43 | 54 | | 6 | |
| FSE0470N0 | 43*54*7.5 KM | 43252-M7001 | 43 | 54 | | 7.5 | |
| FSE0637NB | 43*54*7.5 SC | | 43 | 54 | | 7.5 | |
| FSE0639NB | 43*54*7.5 TB | | 43 | 54 | | 7.5 | |
| FSE0947NB | 43*54*11 DC | | 43 | 54 | | 11 | |
| FSE0937NB | 43*54*11 DC4 | | 43 | 54 | | 11 | |
| FSE0787NB | 43*54*11 TC4(NBR75-80) | | 43 | 54 | | 11 | |
| FSE0645NB | 44*54*5 SC | | 44 | 54 | | 5 | |
| FSE0607NB | 44*54*6 TC | | 44 | 54 | | 6 | |
| FSE0855NB | 44*54*7 TC | | 44 | 54 | | 7 | |
| FSE0941NB | 44*54*7.5 TC | | 44 | 54 | | 7.5 | |
| FSE0963NB | 45*54*4.5 TC | | 45 | 54 | | 4.5 | |
| FSE0612NB | 45*54*5 SB | | 45 | 54 | | 5 | |
| FSE0970NB | 45*54*5.5 TB | | 45 | 54 | | 5.5 | |
| FSE0931NB | 45*54*5.7/9 KB9 | 560361 | 45 | 54 | | 5.7 | 9 |
| FSE0858NB | 45*54*7.5 TC | | 45 | 54 | | 7.5 | |
| FSE0942NB | 45.5*54*5.5/9 KDS-19 | | 45.5 | 54 | | 5.5 | 9 |
| FSE0976NB | 40.5*54.5*7 HTCR | | 40.5 | 54.5 | | 7 | |
| FSE9898NB | 34.93*54.91/61*9.12/14.68 HTA5 | (13750) | 34.93 | 54.91 | 61 | 9.12 | 14.68 |
| FSE0405NB | 24*55*10/12 DC | 03AT30 | 24 | 55 | | 10 | 12 |
| FSE0064NB | 24*55*10/12 TGY(TCY) | 113SG02 | 24 | 55 | | 10 | 12 |
| FSE0600NB | 25*55*8 SA | | 25 | 55 | | 8 | |
| FSE0813NB | 25*55*8 TC | | 25 | 55 | | 8 | |
| FSF0050NB | 25*55/68*8/11 TG5 | 113SL01 | 25 | 55 | 68 | 8 | 11 |
| FSE0547NB | 25*55*9 TC | | 25 | 55 | | 9 | |
| FSE0593NB | 25*55*10 TC | | 25 | 55 | | 10 | |
| FSE0593FB | 25*55*10 TC(FKM)VITON | | 25 | 55 | | 10 | |
| FSE0570NB | 25*55*11 TC | | 25 | 55 | | 11 | |
| FSE0604NB | 27*55*8 TC | | 27 | 55 | | 8 | |
| FSE0518NB | 27.8*55*10 TC | | 27.8 | 55 | | 10 | |
| FSE0958NB | 28*55*7 TC | | 28 | 55 | | 7 | |
| FSE0273NB | 28*55*10 TC | | 28 | 55 | | 10 | |
| FSE0679NB | 30*55*6 TC | | 30 | 55 | | 6 | |
| FSE0032NB | 30*55*7 SC | 113LG21 | 30 | 55 | | 7 | |
| FSE0131NB | 30*55*7 TC | | 30 | 55 | | 7 | |
| FSE0132NB | 30*55*8 DC | | 30 | 55 | | 8 | |
| FSE0106NB | 30*55*8 TC | | 30 | 55 | | 8 | |
| FSE0068NB | 30*55/68*8/11 TCY(TG5Y) | 113SL02 | 30 | 55 | 68 | 8 | 11 |
| FSE0726NB | 30*55*9 TC | Whirlpool | 30 | 55 | | 9 | |
| FSE0224NB | 30*55*10 TC | N12 曲軸, 113LG85 | 30 | 55 | | 10 | |
| FSE0133NS | 30*55*10/12 TGY(S304) | SUS304 SPRING外徑有紋路 | 30 | 55 | | 10 | 12 |
| FSE0031NB | 30*55*11 TC | | 30 | 55 | | 11 | |
| FSE0134NB | 30*55*12 TC | | 30 | 55 | | 12 | |
| FSE0961NB | 32*55*6.5 TC(BLUE) | | 32 | 55 | | 6.5 | |
| FSE0614NB | 32*55*7 TC | | 32 | 55 | | 7 | |
| FSE0614FB | 32*55*7 TC(FKM)VITON | | 32 | 55 | | 7 | |
| FSE0927NB | 32*55*8 SC | | 32 | 55 | | 8 | |
| FSE0280NB | 32*55*8 TC | | 32 | 55 | | 8 | |
| FSE0030NB | 32*55*9 TC | | 32 | 55 | | 9 | |
| FSE0281NB | 32*55*10 TC | | 32 | 55 | | 10 | |
| FSE1106NB | 33*55*9/15 HTC9L | | 33 | 55 | | 9 | 15 |
| FSE0336NB | 33*55*9.5 TB3 | 9-09724-0630彎腳 | 33 | 55 | | 9.5 | |
| FSE0350NB | 33*55*10 TA | | 33 | 55 | | 10 | |
| FSE0882NB | 33*55*10 TC | | 33 | 55 | | 10 | |
| FSE0992NB | 34*55*6 TC | | 34 | 55 | | 6 | |
| FSE0909NB | 34*55*7 TC | | 34 | 55 | | 7 | |

| WLK CODE | OIL SEALS | DESCRIPTION | ID | OD1 | OD2 | H1 | H2 |
|-----------|----------------------------|-------------------------|----|-----|-----|----|------|
| FSE0746NB | 34*55*8 TC | | 34 | 55 | | 8 | |
| FSE0352NB | 34*55*9 TC | | 34 | 55 | | 9 | |
| FSE0408NB | 34*55*10 TC | | 34 | 55 | | 10 | |
| FSE0282NB | 34*55*11 TC | | 34 | 55 | | 11 | |
| FSE0774NB | 34*55*11 TC3 | | 34 | 55 | | 11 | |
| FSE1096NB | 34*55*12 TC | | 34 | 55 | | 12 | |
| FSE0116N0 | 35*55*5 VC | | 35 | 55 | | 5 | |
| FSE1107FB | 35*55*7 SC(VITON) | TC修掉副唇 | 35 | 55 | | 7 | |
| FSE0579NB | 35*55*7 TC | | 35 | 55 | | 7 | |
| FSE0579FB | 35*55*7 TC(VITON) | | 35 | 55 | | 7 | |
| FSE0024NB | 35*55*8 DC | | 35 | 55 | | 8 | |
| FSE0337NB | 35*55*8 TB | | 35 | 55 | | 8 | |
| FSE0029NB | 35*55*8 TC | 0603-26-154 | 35 | 55 | | 8 | |
| FSE0029FB | 35*55*8 TC (FKM)VITON | | 35 | 55 | | 8 | |
| FSE0028NB | 35*55*9 HTC3R | 正確尺寸38*55*9 HTC3R | 35 | 55 | | 9 | |
| FSE0158NB | 35*55*9 TB | | 35 | 55 | | 9 | |
| FSE0157NB | 35*55*9 TC | | 35 | 55 | | 9 | |
| FSE0626AB | 35*55*9/15 HTC9(ACM) BROWN | | 35 | 55 | | 9 | 15 |
| FSE0626NB | 35*55*9/15 HTC9W | 90311-35014 | 35 | 55 | | 9 | 15 |
| FSE0159NB | 35*55*9/15 TC9 | 90311-35007 | 35 | 55 | | 9 | 15 |
| FSE0159AB | 35*55*9/15 TC9(ACM) | | 35 | 55 | | 9 | 15 |
| FSE0602NB | 35*55*9/15.5 TC9 | | 35 | 55 | | 9 | 15.5 |
| FSE0354NB | 35*55*10 TB | | 35 | 55 | | 10 | |
| FSE0288NB | 35*55*10 TC | | 35 | 55 | | 10 | |
| FSE0288NS | 35*55*10 TC(S304) | S304白鐵彈簧 | 35 | 55 | | 10 | |
| FSE0288FB | 35*55*10 TC(VITON) | | 35 | 55 | | 10 | |
| FSE0966NB | 35*55*11 HSMY | 14782 | 35 | 55 | | 11 | |
| FSE0554NB | 35*55*11 HTB2R | 43252-01G00 | 35 | 55 | | 11 | |
| FSE0682NB | 35*55*11 HTCR | | 35 | 55 | | 11 | |
| FSE0682QB | 35*55*11 HTCR(VMQ) | | 35 | 55 | | 11 | |
| FSE0160QB | 35*55*11 SC (VMQ) | | 35 | 55 | | 11 | |
| FSE0105NB | 35*55*11 TC | 90311-35071;38212-01300 | 35 | 55 | | 11 | |
| FSE0105FB | 35*55*11 TC (VITON) | 90311-35071 | 35 | 55 | | 11 | |
| FSE0105NS | 35*55*11 TC(S304 SPRING) | SUS304 SPRING | 35 | 55 | | 11 | |
| FSE0027NB | 35*55*11 TC6 | | 35 | 55 | | 11 | |
| FSE0671NB | 35*55*11 TCN | | 35 | 55 | | 11 | |
| FSE0803NB | 35*55*11 TCV | | 35 | 55 | | 11 | |
| FSE0162NB | 35*55*12 SB | | 35 | 55 | | 12 | |
| FSE0161NB | 35*55*12 TB | | 35 | 55 | | 12 | |
| FSE0026NB | 35*55*12 TC | | 35 | 55 | | 12 | |
| FSE0867NB | 36*55*7 TC | | 36 | 55 | | 7 | |
| FSE0323NB | 36*55*10 DC | | 36 | 55 | | 10 | |
| FSE0779NB | 36*55*10 TC | | 36 | 55 | | 10 | |
| FSE1005NB | 36*55*11 TB | | 36 | 55 | | 11 | |
| FSE0732NB | 36*55*11/16 TC39 | | 36 | 55 | | 11 | 16 |
| FSE0842NB | 36*55*12 TC | | 36 | 55 | | 12 | |
| FSE0290NB | 37*55*8 TC | | 37 | 55 | | 8 | |
| FSE0745NB | 37*55*9 TC | | 37 | 55 | | 9 | |
| FSE0701NB | 37*55*10/12 TCY(BROWN) | | 37 | 55 | | 10 | 12 |
| FSE0956NB | 37*55*11 TC | | 37 | 55 | | 11 | |
| FSE0688NB | 38*55*7 SC | | 38 | 55 | | 7 | |
| FSE0325NB | 38*55*7 TC | | 38 | 55 | | 7 | |
| FSE0325FB | 38*55*7 TC(VITON) | | 38 | 55 | | 7 | |
| FSE0381NO | 38*55*8 KC3 W/GREASE | (RS001) | 38 | 55 | | 8 | |
| FSE1108NB | 38*55*8 SB | | 38 | 55 | | 8 | |
| FSE0025NB | 38*55*8 TC | KND70A/105,RK80/RK70曲軸 | 38 | 55 | | 8 | |

| WLK CODE | OIL SEALS | DESCRIPTION | ID | OD1 | OD2 | H1 | H2 |
|-----------|----------------------------------|--------------------------|----|-----|------|------|-----|
| FSE0025FB | 38*55*8 TC (FKM)VITON | | 38 | 55 | | 8 | |
| FSE0025QB | 38*55*8 TC(VMQ) | | 38 | 55 | | 8 | |
| FSE0340NB | 38*55*8.5 HTZR(HTBR) | 90311-38020,NJ891 | 38 | 55 | | 8.5 | |
| FSE0340QB | 38*55*8.5 HTZR(VMQ) | 11238 | 38 | 55 | | 8.5 | |
| FSE0074NB | 38*55*9 HTC3R | 13510-H1010 | 38 | 55 | | 9 | |
| FSE0187NB | 38*55*9 HTCR | 13510-H1000/18000 | 38 | 55 | | 9 | |
| FSE1081NB | 38*55*9 TB3 | | 38 | 55 | | 9 | |
| FSE0023NB | 38*55*9 TC | | 38 | 55 | | 9 | |
| FSE0771NB | 38*55*10 SC | | 38 | 55 | | 10 | |
| FSE0293NB | 38*55*10 TC | | 38 | 55 | | 10 | |
| FSE0293FB | 38*55*10 TC(VITON) | | 38 | 55 | | 10 | |
| FSE0022NB | 38*55*10.5 TC | | 38 | 55 | | 10.5 | |
| FSE0241NB | 38*55/60*10.5 SC5Y | | 38 | 55 | 60 | 10.5 | |
| FSE0021NB | 38*55/63.5*10.5 SC5Y | 2T CAM SHAFT | 38 | 55 | 63.5 | 10.5 | |
| FSE0674NB | 40*55*5 TC | | 40 | 55 | | 5 | |
| FSE0743NB | 40*55*6 HTCR | 90311-40022 | 40 | 55 | | 6 | |
| FSE0952NB | 40*55*6 TC | | 40 | 55 | | 6 | |
| FSE0891NB | 40*55*6/6.5 TCV | | 40 | 55 | | 6 | 6.5 |
| FSE0891FB | 40*55*6/6.5 TCV(VITON) | | 40 | 55 | | 6 | 6.5 |
| FSE0991NB | 40*55*6.5 SC | | 40 | 55 | | 6.5 | |
| FSE0632NB | 40*55/59*6.5 Y | FCMU1103 | 40 | 55 | 59 | 6.5 | |
| FSE0684NB | 40*55*7 HTCR | ISUZU 車用 | 40 | 55 | | 7 | |
| FSE0020NB | 40*55*7 SB | | 40 | 55 | | 7 | |
| FSE0098NB | 40*55*7 TC | | 40 | 55 | | 7 | |
| FSE0098FB | 40*55*7 TC(VITON)FKM | | 40 | 55 | | 7 | |
| FSE0098QB | 40*55*7 TC(VMQ) | | 40 | 55 | | 7 | |
| FSE0790NB | 40*55*7 TZ | | 40 | 55 | | 7 | |
| FSE0078NB | 40*55*8 HTCR | 0187-10-507B | 40 | 55 | | 8 | |
| FSE0078AB | 40*55*8 HTCR(ACM) | | 40 | 55 | | 8 | |
| FSE0018NB | 40*55*8 SC | | 40 | 55 | | 8 | |
| FSE0019NB | 40*55*8 TC | 0187-10-507B | 40 | 55 | | 8 | |
| FSE0019NS | 40*55*8 TC(S304 SPRING) | SUS304 SPRING | 40 | 55 | | 8 | |
| FSE0019FB | 40*55*8 TC(VITON) | | 40 | 55 | | 8 | |
| FSE9897NB | 40*55/65*8.2 KB59 Green Painting | 15746 | 40 | 55 | 65 | 8.2 | |
| FSE0904NB | 40*55*9 HTCR | | 40 | 55 | | 9 | |
| FSE0017NB | 40*55*9 SC6Y | NM65 曲軸 GJ 2361Q | 40 | 55 | | 9 | |
| FSE0393NB | 40*55*9 TB | 32136-31300 | 40 | 55 | | 9 | |
| FSE0085NB | 40*55*9 TC | AH2361F | 40 | 55 | | 9 | |
| FSE0205NB | 40*55*10 DC | | 40 | 55 | | 10 | |
| FSE0300NB | 40*55*10 TC | | 40 | 55 | | 10 | |
| FSE0796NB | 40*55*12 TC | | 40 | 55 | | 12 | |
| FSE0796FB | 40*55*12 TC(VITON) | | 40 | 55 | | 12 | |
| FSE0468NB | 41*55*6 TB | 90311-41001(41003) | 41 | 55 | | 6 | |
| FSE1082NB | 41*55*7 TC | | 41 | 55 | | 7 | |
| FSE1083NB | 41*55*7 TZ | | 41 | 55 | | 7 | |
| FSE0594NB | 41*55*7/12 TB9 | 90311-41004 | 41 | 55 | | 7 | 12 |
| FSE0329NB | 41*55*9 TC | | 41 | 55 | | 9 | |
| FSE0495NB | 42*55*6 TC | | 42 | 55 | | 6 | |
| FSE0981NB | 42*55*7 SC | | 42 | 55 | | 7 | |
| FSE0217NB | 42*55*7 TB | 09283-42008, 90311-42055 | 42 | 55 | | 7 | |
| FSE0091NB | 42*55*7 TC | 0187-26-154 | 42 | 55 | | 7 | |
| FSE0718NB | 42*55*7.5/9 Y | | 42 | 55 | | 7.5 | 9 |
| FSE0975NB | 42*55*8 HTCR | | 42 | 55 | | 8 | |
| FSE0474NB | 42*55*8 KC(KES) | 40232-21000 | 42 | 55 | | 8 | |
| FSE0982NB | 42*55*8 SC | | 42 | 55 | | 8 | |
| FSE0016NB | 42*55*8 TC | 40232-21000 | 42 | 55 | | 8 | |
| FSE0016FB | 42*55*8 TC(VITON) | | 42 | 55 | | 8 | |

| WLK CODE | OIL SEALS | DESCRIPTION | ID | OD1 | OD2 | H1 | H2 |
|-----------|---|-----------------------|-------|-------|-------|-------|------|
| FSE0016QB | 42*55*8 TC(VMQ) | | 42 | 55 | | 8 | |
| FSE0411NB | 42*55*8 TCK W/Felt | | 42 | 55 | | 8 | |
| FSE0395NB | 42*55*9 TB | | 42 | 55 | | 9 | |
| FSE0084NB | 42*55*9 TC | 0187-26-154 | 42 | 55 | | 9 | |
| FSE0084AB | 42*55*9 TC(ACM) | | 42 | 55 | | 9 | |
| FSE0307NB | 42*55*10 TC | | 42 | 55 | | 10 | |
| FSE0307FB | 42*55*10 TC(VITON) | | 42 | 55 | | 10 | |
| FSE0069NB | 42*55/63*12 TC | | 42 | 55 | 63 | 12 | |
| FSE0628NB | 42.8*55*11 TC | MB-919210 | 42.8 | 55 | | 11 | |
| FSE0709NB | 43*55*6 HTCR | | 43 | 55 | | 6 | |
| FSE1084NB | 43*55*7 TC | | 43 | 55 | | 7 | |
| FSE1084FB | 43*55*7 TC(VITON) | | 43 | 55 | | 7 | |
| FSE0775NB | 43*55*7.5 KC | | 43 | 55 | | 7.5 | |
| FSE0523NB | 43*55*8 TC | | 43 | 55 | | 8 | |
| FSE1008N | 43*55*9.5/10.5 TC4 | | 43 | 55 | | 9.5 | 10.5 |
| FSE0713NB | 43*55*10 TC | | 43 | 55 | | 10 | |
| FSE0543NB | 44*55*5 SB(BROWN) | | 44 | 55 | | 5 | |
| FSE0220NB | 44*55*7 TC | | 44 | 55 | | 7 | |
| FSE0136N0 | 45*55*4 KB | | 45 | 55 | | 4 | |
| FSE0983NB | 45*55*4 SC | | 45 | 55 | | 4 | |
| FSE0914NB | 45*55*5 SB | | 45 | 55 | | 5 | |
| FSE0993NB | 45*55*5 TC | | 45 | 55 | | 5 | |
| FSE0791NB | 45*55*7 SB | | 45 | 55 | | 7 | |
| FSE0510NB | 45*55*7 SC | | 45 | 55 | | 7 | |
| FSE0738NB | 45*55*7 TB | 1828-4503/04-00 | 45 | 55 | | 7 | |
| FSE0312NB | 45*55*7 TC | | 45 | 55 | | 7 | |
| FSE0568NB | 45*55*7.5 TB | 9828-45104 | 45 | 55 | | 7.5 | |
| FSE0528NB | 45*55*8 TC | | 45 | 55 | | 8 | |
| FSE0601NB | 45*55*10 TC | | 45 | 55 | | 10 | |
| FSE0601FB | 45*55*10 TC(FKM)VITON | | 45 | 55 | | 10 | |
| FSE9896NB | 39.70*55.17/62.12*13.11 HTA5 Red Painting | (15716) | 39.7 | 55.17 | 62.12 | 13.11 | |
| FSE0198NB | 39.4*55.25*8.2 HTC | 1.551*2.175*0.322 HTC | 39.4 | 55.25 | | 8.2 | |
| FSC0444NB | 26.5*55.5*12.5 SC | D9NN7R510BA | 26.5 | 55.5 | | 12.5 | |
| FSF0545NS | 27*55.5/70*9/18.5 TC3Y | 27*70/55*9/18.5 | 27 | 55.5 | 70 | 9 | 18.5 |
| FSE0015NB | 28.6*55.5*12.5 HSGR | | 28.6 | 55.5 | | 12.5 | |
| FSE0740NB | 38*55.5*9 TB | | 38 | 55.5 | | 9 | |
| FSE0977NB | 39*55.5*9 SC | | 39 | 55.5 | | 9 | |
| FSE0827NB | 22*56*7 TC | | 22 | 56 | | 7 | |
| FSE1090NB | 27.95*56*10 TC | | 27.95 | 56 | | 10 | |
| FSE0870NB | 28*56*7 TC | | 28 | 56 | | 7 | |
| FSE0115NB | 28*56*8 DC | | 28 | 56 | | 8 | |
| FSE0888NB | 28*56*10 TC | | 28 | 56 | | 10 | |
| FSE0834NB | 30*56*7 TC | | 30 | 56 | | 7 | |
| FSE0754NB | 30*56*8 TC | | 30 | 56 | | 8 | |
| FSE0135NB | 30*56*10 SC | | 30 | 56 | | 10 | |
| FSE0638NB | 30*56*10 TC | | 30 | 56 | | 10 | |
| FSE0642NB | 30*56*12 TC | | 30 | 56 | | 12 | |
| FSE0836NB | 32*56*8 TC | | 32 | 56 | | 8 | |
| FSE0807NB | 32*56*10 TB | | 32 | 56 | | 10 | |
| FSE0283NB | 32*56*10 TC | | 32 | 56 | | 10 | |
| FSE0793NB | 32*56*12 SC | | 32 | 56 | | 12 | |
| FSE0586NB | 33*56*8/13 TC9 | 38342-31X01 | 33 | 56 | | 8 | 13 |
| FSE0839NB | 33*56*12 TC | | 33 | 56 | | 12 | |
| FSE0840NB | 34*56*8 TC | | 34 | 56 | | 8 | |
| FSE0549NB | 34*56*10 TC | | 34 | 56 | | 10 | |
| FSE0686NB | 35*56*6 TC | | 35 | 56 | | 6 | |
| FSE0580NB | 35*56*7 TC | | 35 | 56 | | 7 | |

| WLK CODE | OIL SEALS | DESCRIPTION | ID | OD1 | OD2 | H1 | H2 |
|-----------|--------------------------|-------------------------|----|-----|------|-----|------|
| FSE0567NB | 35*56*8 TC | | 35 | 56 | | 8 | |
| FSE0809NB | 35*56*8/11.5 HTC9L | AH2093G | 35 | 56 | | 8 | 11.5 |
| FSE0471NB | 35*56*8/12.5 HTC9R | 91205-611-003高度齒狀 | 35 | 56 | | 8 | 12.5 |
| FSE0629NB | 35*56*9 TC | | 35 | 56 | | 9 | |
| FSE0163NB | 35*56*9/12 TC9 | MD-706433,91205-611-003 | 35 | 56 | | 9 | 12 |
| FSE0077NB | 35*56*9/15 TC9Y | F001-27-238 | 35 | 56 | | 9 | 15 |
| FSE0710NB | 35*56*10 SC | | 35 | 56 | | 10 | |
| FSE0100NB | 35*56*10 TC | | 35 | 56 | | 10 | |
| FSE0100NS | 35*56*10 TC(S304 SPRING) | SUS304 SPRING | 35 | 56 | | 10 | |
| FSE0100FB | 35*56*10 TC(VITON) | | 35 | 56 | | 10 | |
| FSE0987NB | 35*56*10 TC4(Brown)NBR80 | | 35 | 56 | | 10 | |
| FSE0609NB | 35*56*12 SB | | 35 | 56 | | 12 | |
| FSE0631NB | 35*56*12 TB | | 35 | 56 | | 12 | |
| FSE0384NB | 35*56*12 TC | | 35 | 56 | | 12 | |
| FSE9894FB | 35*56/63.6*16 TB59Y(FKM) | 14007(VITON)BROWN | 35 | 56 | 63.6 | 16 | |
| FSE0843NB | 36*56*8 TC | | 36 | 56 | | 8 | |
| FSE0800NB | 36*56*9 TC | | 36 | 56 | | 9 | |
| FSE0625NB | 36*56*10 SC | | 36 | 56 | | 10 | |
| FSE0846NB | 37*56*9 TB | | 37 | 56 | | 9 | |
| FSE0748NB | 38*56*7 TC | | 38 | 56 | | 7 | |
| FSE0929NB | 38*56*8 TC | | 38 | 56 | | 8 | |
| FSE0574NB | 38*56*9 TC | | 38 | 56 | | 9 | |
| FSE0715NB | 38*56*10 SC | | 38 | 56 | | 10 | |
| FSE0719NB | 38*56*10 TB | | 38 | 56 | | 10 | |
| FSE0320NB | 38*56*10 TC | | 38 | 56 | | 10 | |
| FSE0320FB | 38*56*10 TC(VITON) | | 38 | 56 | | 10 | |
| FSE0190NB | 38*56*11 SC | | 38 | 56 | | 11 | |
| FSE0014NB | 38*56*11 TC4 | | 38 | 56 | | 11 | |
| FSE0869NB | 38*56*12 SC | | 38 | 56 | | 12 | |
| FSE0572NB | 38*56*12 TC | | 38 | 56 | | 12 | |
| FSE0780NB | 39*56*7 TC | | 39 | 56 | | 7 | |
| FSE0595NB | 40*56*6 TC | | 40 | 56 | | 6 | |
| FSE0560NB | 40*56*6.5 HTBR | 1-09625-357-0 | 40 | 56 | | 6.5 | |
| FSE0206NB | 40*56*7 HTCR | 8-94339-997-0 | 40 | 56 | | 7 | |
| FSE0206AB | 40*56*7 HTCR(ACM) | | 40 | 56 | | 7 | |
| FSE0301NB | 40*56*7 TC | | 40 | 56 | | 7 | |
| FSE0301FB | 40*56*7 TC(VITON) | | 40 | 56 | | 7 | |
| FSE0090NB | 40*56*8 HTBR | | 40 | 56 | | 8 | |
| FSE0109NB | 40*56*8 HTCR | | 40 | 56 | | 8 | |
| FSE0874NB | 40*56*8 TB | | 40 | 56 | | 8 | |
| FSE0207NB | 40*56*8 TC | 38342-M8001 | 40 | 56 | | 8 | |
| FSE0207FB | 40*56*8 TC(VITON)FKM | | 40 | 56 | | 8 | |
| FSE0690NB | 40*56*8/11.5 HTC9L | AH2365E | 40 | 56 | | 8 | 11.5 |
| FSE0493NB | 40*56*8/13.5 TC9 | 38342-31X00 | 40 | 56 | | 8 | 13.5 |
| FSE0208NB | 40*56*9 TC | | 40 | 56 | | 9 | |
| FSE0683NB | 40*56*9/12.5 HTC9 | BH3146E(高度有6齒) | 40 | 56 | | 9 | 12.5 |
| FSE0302NB | 40*56*10 TC | | 40 | 56 | | 10 | |
| FSE0530NB | 40*56*12 SC | | 40 | 56 | | 12 | |
| FSE0906NB | 40*56*12 TC | | 40 | 56 | | 12 | |
| FSE0260NB | 40*56/65*20 TCY | 38342-D2100 | 40 | 56 | 65 | 20 | |
| FSE0532NB | 41*56*7 SA | | 41 | 56 | | 7 | |
| FSE0213NB | 41*56*7 SB | 43232-H1000 | 41 | 56 | | 7 | |
| FSE0214NB | 41*56*7 TB | | 41 | 56 | | 7 | |
| FSE0103NB | 41*56*7 TC | | 41 | 56 | | 7 | |
| FSE0103NS | 41*56*7 TC(S304 SPRING) | | 41 | 56 | | 7 | |
| FSE0727NB | 41*56*8 HTCR | | 41 | 56 | | 8 | |
| FSE0892NB | 41*56*8 TC | | 41 | 56 | | 8 | |

| WLK CODE | OIL SEALS | DESCRIPTION | ID | OD1 | OD2 | H1 | H2 |
|-----------|--------------------------|---------------------|-------|-------|-----|------|-----|
| FSE0087NB | 42*56*7 HTCR | | 42 | 56 | | 7 | |
| FSE0087QB | 42*56*7 HTCR (VMQ) | | 42 | 56 | | 7 | |
| FSE0218NB | 42*56*7 SC | | 42 | 56 | | 7 | |
| FSE0319NB | 42*56*7 TC | | 42 | 56 | | 7 | |
| FSE0354FS | 42*56*7 TC (FKM)S304 | (FKM) SUS304 SPRING | 42 | 56 | | 7 | |
| FSE0354FU | 42*56*7 TC (FKM) S316 | (FKM)SUS316 SPRING | 42 | 56 | | 7 | |
| FSE0319QB | 42*56*7 TC (VMQ) | | 42 | 56 | | 7 | |
| FSE0013NB | 42*56/63*7 HSBY(R) | | 42 | 56 | 63 | 7 | |
| FSE0647NB | 42*56*8 TC | | 42 | 56 | | 8 | |
| FSE0669NB | 42*56*10 TC | | 42 | 56 | | 10 | |
| FSE0782N0 | 43*56*7 KC | | 43 | 56 | | 7 | |
| FSE1004NB | 43.5*56*7 TC | | 43.5 | 56 | | 7 | |
| FSE0485NB | 44*56*6.5 SB | | 44 | 56 | | 6.5 | |
| FSE0856NB | 44*56*7 SB | | 44 | 56 | | 7 | |
| FSE0221NB | 45*56*5 SB | | 45 | 56 | | 5 | |
| FSE0654NB | 45*56*7 TC | | 45 | 56 | | 7 | |
| FSE0986NB | 45*56*10 TC | | 45 | 56 | | 10 | |
| FSE1003NB | 45.6*56*7 TC | | 45.6 | 56 | | 7 | |
| FSE0223NB | 46*56*4 TB | | 46 | 56 | | 4 | |
| FSE0582NB | 47*56*7 TB | 38212-Z5000 | 47 | 56 | | 7 | |
| FSE0590NB | 47*56*7 TC | | 47 | 56 | | 7 | |
| FSE0533NB | 49*56*8 KZ3 | W029-261-57 | 49 | 56 | | 8 | |
| FSE0735NB | 42*56.2*6 KC | 91252-692-003/5 | 42 | 56.2 | | 6 | |
| FSE0833NB | 28*57*10 TC | | 28 | 57 | | 10 | |
| FSE0835NB | 30*57*7 TC | | 30 | 57 | | 7 | |
| FSE0548NB | 30*57*8 SC | | 30 | 57 | | 8 | |
| FSE0871NB | 30*57*10 TC | | 30 | 57 | | 10 | |
| FSE0923NB | 32*57*8 TC | | 32 | 57 | | 8 | |
| FSE0837NB | 32*57*12 SC | | 32 | 57 | | 12 | |
| FSE0760NB | 33*57*6 SC | | 33 | 57 | | 6 | |
| FSE0759NB | 33*57*7 SC | | 33 | 57 | | 7 | |
| FSE0520NB | 34*57*6 TC | | 34 | 57 | | 6 | |
| FSE0277NB | 35*57*8 TC | 10090 | 35 | 57 | | 8 | |
| FSE0496NB | 35*57*9 TC | | 35 | 57 | | 9 | |
| FSE0391NB | 35*57*9/16 TC9 | 90311-35046 | 35 | 57 | | 9 | 16 |
| FSE9893NB | 35*57/64*9.7/16 TB5Y | 13735 | 35 | 57 | 64 | 9.7 | 16 |
| FSE0164NB | 35*57*10 TC | | 35 | 57 | | 10 | |
| FSE0633NB | 37*57*10 HTCL | AH7714P | 37 | 57 | | 10 | |
| FSE0176NB | 37*57*10 TC | 9828-01985 | 37 | 57 | | 10 | |
| FSE0176FB | 37*57*10 TC(VITON) | | 37 | 57 | | 10 | |
| FSE0356NB | 38*57*8 TC | | 38 | 57 | | 8 | |
| FSE0900NB | 38*57*10 SC | | 38 | 57 | | 10 | |
| FSE0930NB | 39*57*11/17 TC9 | 內徑東較多 | 39 | 57 | | 11 | 17 |
| FSE0149N0 | 39*57/63*16 Y 4824 | Hoover, Servis | 39 | 57 | 63 | 16 | |
| FSE0849NB | 40*57*8 TC | | 40 | 57 | | 8 | |
| FSE0360NB | 40*57*10 TC | | 40 | 57 | | 10 | |
| FSE0012NB | 45*57*5/7.5 TC | NT65 曲軸 | 45 | 57 | | 5 | 7.5 |
| FSE0730NB | 45*57*6.5 HTCR | 11240 | 45 | 57 | | 6.5 | |
| FSE0364NB | 45*57*7 TC | | 45 | 57 | | 7 | |
| FSE0859NB | 45*57*9 TC | | 45 | 57 | | 9 | |
| FSE0866NB | 45*57*11 DC | | 45 | 57 | | 11 | |
| FSE9989NB | 39.56*57.1*13 SA(W/FELT) | | 39.56 | 57.1 | | 13 | |
| FSE9975NB | 28.58*57.15*6.35 SB | | 28.58 | 57.15 | | 6.35 | |
| FSE9906NB | 28.58*57.15*9.53 TC | | 28.58 | 57.15 | | 9.53 | |
| FSE9974NB | 31.75*57.15*6.35 SB | | 31.75 | 57.15 | | 6.35 | |
| FSE9973NB | 31.75*57.15*6.35 SC | | 31.75 | 57.15 | | 6.35 | |
| FSE9910NB | 31.75*57.15*6.35 TC | | 31.75 | 57.15 | | 6.35 | |

| WLK CODE | OIL SEALS | DESCRIPTION | ID | OD1 | OD2 | H1 | H2 |
|-----------|--------------------------------------|----------------------|--------|-------|------|-------|-------|
| FSE9945NB | 31.75*57.15*7.95 SC | | 31.75 | 57.15 | | 7.95 | |
| FSE9959NB | 31.75*57.15*9.53 TC | 1.250*2.250*0.375 TC | 31.75 | 57.15 | | 9.53 | |
| FSE9962NB | 31.75*57.15*12.7 SA | | 31.75 | 57.15 | | 12.7 | |
| FSE9930NB | 31.75*57.15*12.7 TC | | 31.75 | 57.15 | | 12.7 | |
| FSE9972NB | 33.34*57.15*9.52 SC | | 33.34 | 57.15 | | 9.52 | |
| FSE9983NB | 34.78*57.15*7.9 TC | 1.370*2.250*0.310 TC | 34.78 | 57.15 | | 7.9 | |
| FSE9939NB | 34.92*57.15*7.95 TC | | 34.92 | 57.15 | | 7.95 | |
| FSE9939AB | 34.92*57.15*7.95 TC(ACM) | | 34.92 | 57.15 | | 7.95 | |
| FSE9939FB | 34.92*57.15*7.95 TC(FKM) | VITON | 34.92 | 57.15 | | 7.95 | |
| FSE9918NB | 34.92*57.15*9.52 SC | | 34.92 | 57.15 | | 9.52 | |
| FSE9923NB | 34.92*57.15*9.53 TC | | 34.92 | 57.15 | | 9.53 | |
| FSE9943NB | 34.92*57.15*12.7 TB | 1.375*2.250*0.500 | 34.92 | 57.15 | | 12.7 | |
| FSE0261NB | 34.925*57.15*12.7 TB | 1.375*2.250*0.500 TB | 34.925 | 57.15 | | 12.7 | |
| FSE9969NB | 34.93*57.15*6.35 TC | | 34.93 | 57.15 | | 6.35 | |
| FSE0864NB | 34.93*57.15*7.95 TCV | 1.375*2.250*0.313TCV | 34.93 | 57.15 | | 7.95 | |
| FSE9951NB | 34.93*57.15*9.53 TB | | 34.93 | 57.15 | | 9.53 | |
| FSE9901NB | 34.93*57.15/63.5*11.13/22.63 HTB59LY | Red Painting | 34.93 | 57.15 | 63.5 | 11.13 | 22.63 |
| FSE9936NB | 34.93*57.15*12.7 TC | | 34.93 | 57.15 | | 12.7 | |
| FSE9872NB | 36.53*57.15*7.95 SB | | 36.53 | 57.15 | | 7.95 | |
| FSE9892NB | 36.53*57.15*7.95 TB | | 36.53 | 57.15 | | 7.95 | |
| FSE9963NB | 36.53*57.15*9.53 TB | | 36.53 | 57.15 | | 9.53 | |
| FSE9914NB | 36.53*57.15*9.53 TC | | 36.53 | 57.15 | | 9.53 | |
| FSE9873FB | 38.1*57.15*7.9 TCV(FKM) | VITON | 38.1 | 57.15 | | 7.9 | |
| FSE9967NB | 38.1*57.15*7.95 SC | | 38.1 | 57.15 | | 7.95 | |
| FSE9967QB | 38.1*57.15*7.95 SC(VMQ) | | 38.1 | 57.15 | | 7.95 | |
| FSE9933NB | 38.1*57.15*7.95 TB | | 38.1 | 57.15 | | 7.95 | |
| FSF9983NB | 38.1*57.15*7.95 TC | | 38.1 | 57.15 | | 7.95 | |
| FSF9983FB | 38.1*57.15*7.95 TC(VITON) | | 38.1 | 57.15 | | 7.95 | |
| FSE9992NB | 38.1*57.15*9.52 TC | 1.500*2.250*0.375 TC | 38.1 | 57.15 | | 9.52 | |
| FSE9912NB | 38.1*57.15*12.7 SC | | 38.1 | 57.15 | | 12.7 | |
| FSE0641NB | 40*57.15*10 SB | | 40 | 57.15 | | 10 | |
| FSE0820NB | 40*57.15*10 TC | | 40 | 57.15 | | 10 | |
| FSE0700NB | 40.08*57.15*7.95/17.07HT | HTC9L BH4989E | 40.08 | 57.15 | | 7.95 | 17.07 |
| FSE9966NB | 41.28*57.15*6.35 TC | | 41.28 | 57.15 | | 6.35 | |
| FSE9948FB | 41.28*57.15*7.95 TB(FKM) | VITON | 41.28 | 57.15 | | 7.95 | |
| FSE9908NB | 41.28*57.15*7.95 TC | | 41.28 | 57.15 | | 7.95 | |
| FSE9889NB | 41.28*57.15*9.53 TC | | 41.28 | 57.15 | | 9.53 | |
| FSF9907NB | 44.45*57.15*6.35 SB | | 44.45 | 57.15 | | 6.35 | |
| FSF9886NB | 44.45*57.15*6.35 TC | | 44.45 | 57.15 | | 6.35 | |
| FSF9900NB | 44.45*57.15*7.95 SC | | 44.45 | 57.15 | | 7.95 | |
| FSF9965NB | 44.45*57.15*7.95 TC | | 44.45 | 57.15 | | 7.95 | |
| FSF9837NB | 44.45*57.15*9.53 SB | | 44.45 | 57.15 | | 9.53 | |
| FSF9865NB | 44.45*57.15*9.53 TC | | 44.45 | 57.15 | | 9.53 | |
| FSE0265NB | 35*57.25*7.9 TC C256 | 1.375*2.250*0.310 TC | 35 | 57.25 | | 7.9 | |
| FSE0199NB | 39.67*57.53*9.52 SC | 1.562*2.265*0.375 SC | 39.67 | 57.53 | | 9.52 | |
| FSE0739NB | 33.35*57.94*12.7 TB | | 33.35 | 57.94 | | 12.7 | |
| FSE9941NB | 34.92*57.94*7.95 VB | | 34.92 | 57.94 | | 7.95 | |
| FSE0831NB | 25*58*10 TC | | 25 | 58 | | 10 | |
| FSE0865NB | 28*58*7 SB | | 28 | 58 | | 7 | |
| FSE1103NB | 28*58*10 TC | | 28 | 58 | | 10 | |
| FSE0812NB | 30*58*8 TC | | 30 | 58 | | 8 | |
| FSE0347NB | 30*58*10 TC | | 30 | 58 | | 10 | |
| FSE0838NB | 32*58*7 TC | | 32 | 58 | | 7 | |
| FSE0284NB | 32*58*8 TC | | 32 | 58 | | 8 | |
| FSE1094NB | 32*58*10 TC | | 32 | 58 | | 10 | |
| FSE0397NB | 32*58*12 TB | 38189-18000 | 32 | 58 | | 12 | |
| FSE0142NB | 32*58*12 TC | | 32 | 58 | | 12 | |

| WLK CODE | OIL SEALS | DESCRIPTION | ID | OD1 | OD2 | H1 | H2 |
|-----------|----------------------------|--------------------------|------|-----|-----|------|------|
| FSE0353NB | 34*58*8 TB | | 34 | 58 | | 8 | |
| FSE0788NB | 34*58*8 TC | | 34 | 58 | | 8 | |
| FSE0075NB | 35*58*6 SA | | 35 | 58 | | 6 | |
| FSE0526NB | 35*58*7 TB | | 35 | 58 | | 7 | |
| FSE0789NB | 35*58*8 TB | | 35 | 58 | | 8 | |
| FSE0659NB | 35*58*8 TC | | 35 | 58 | | 8 | |
| FSE0650NB | 35*58*8/11.5 HTC9R Brown | BH0220E | 35 | 58 | | 8 | 11.5 |
| FSE0343NB | 35*58*8.5 SCY(SCAY) | MB-664588 | 35 | 58 | | 8.5 | |
| FSE0905NB | 35*58*9 TC | | 35 | 58 | | 9 | |
| FSE0166NB | 35*58*10 SCAY | MB-092527,MB-664588 | 35 | 58 | | 10 | |
| FSE0953NB | 35*58*10 TB | | 35 | 58 | | 10 | |
| FSE0165NB | 35*58*10 TC | | 35 | 58 | | 10 | |
| FSE9895NB | 35*58/67*11/19 HTBG59 | | 35 | 58 | 67 | 11 | 19 |
| FSE0011NB | 35*58*12 SC | DF195 起動 | 35 | 58 | | 12 | |
| FSE0010NB | 35*58*12 TC | | 35 | 58 | | 12 | |
| FSE0815NB | 36*58*8 TC | | 36 | 58 | | 8 | |
| FSE0640NB | 36*58*10 SC | | 36 | 58 | | 10 | |
| FSE0522NB | 36*58*10 TC | | 36 | 58 | | 10 | |
| FSE0536NB | 36*58*12 TC | | 36 | 58 | | 12 | |
| FSE0009NB | 36*58*12.5 TB | | 36 | 58 | | 12.5 | |
| FSE0173NB | 36*58*15 ASW Green | VW 4SPD GOLF DRIVE SHAFT | 36 | 58 | | 15 | |
| FSE0873NB | 37*58*7 TC | | 37 | 58 | | 7 | |
| FSE0757NB | 37*58*13 SC | | 37 | 58 | | 13 | |
| FSE0177NB | 37*58*13 TC | | 37 | 58 | | 13 | |
| FSE0978NB | 38*58*7 TC | | 38 | 58 | | 7 | |
| FSE0463NB | 38*58*8 TB | | 38 | 58 | | 8 | |
| FSE0357NB | 38*58*8 TC | | 38 | 58 | | 8 | |
| FSE0357QB | 38*58*8 TC(VMQ) | | 38 | 58 | | 8 | |
| FSE0761NB | 38*58*8 TZ | | 38 | 58 | | 8 | |
| FSE0955NB | 38*58*8.5 HTCR | | 38 | 58 | | 8.5 | |
| FSE0756NB | 38*58*9/13 TAY | | 38 | 58 | | 9 | 13 |
| FSE0294NB | 38*58*10 TC | | 38 | 58 | | 10 | |
| FSE0008NB | 38*58*10.5 SC | | 38 | 58 | | 10.5 | |
| FSE0191NB | 38*58*11 HTCR | 90043-11023 | 38 | 58 | | 11 | |
| FSE0191QB | 38*58*11 HTCR(VMQ) | | 38 | 58 | | 11 | |
| FSE0007NB | 38*58*11 TB3 | 90311-38040/43/16 | 38 | 58 | | 11 | |
| FSE0464NB | 38*58*11 TBR | | 38 | 58 | | 11 | |
| FSE0006NB | 38*58*11 TC | 90311-38140 | 38 | 58 | | 11 | |
| FSE0006QB | 38*58*11 TC (VMQ) | | 38 | 58 | | 11 | |
| FSE0651NB | 38*58*11 TCN(NBR90 Shore) | AP2240G | 38 | 58 | | 11 | |
| FSE0663NB | 38*58*11/17 TC9 | 38342-01B00 | 38 | 58 | | 11 | 17 |
| FSE0192NB | 38*58*18.3 ACF | 90311-38005 | 38 | 58 | | 18.3 | |
| FSE0339NB | 38*58*18.5 ACF | 90311-38005 有蓋型 | 38 | 58 | | 18.5 | |
| FSE0527NB | 38.5*58*8.5 HTCR | 90311-38022 | 38.5 | 58 | | 8.5 | |
| FSE0465NB | 38.5*58*11 HTCR | 90311-38013 | 38.5 | 58 | | 11 | |
| FSE0196NB | 38.5*58*11 TC3 | 90311-38024 | 38.5 | 58 | | 11 | |
| FSE1007NB | 39*58*6 TC | | 39 | 58 | | 6 | |
| FSE0113N0 | 40*58*6 VC | | 40 | 58 | | 6 | |
| FSE0387NB | 40*58*7 SEB(SM) | | 40 | 58 | | 7 | |
| FSE0810NB | 40*58*7 TC | | 40 | 58 | | 7 | |
| FSE0237NB | 40*58*7/12 TC9 | | 40 | 58 | | 7 | 12 |
| FSE0005NB | 40*58*8 TC | ME-623281;MH-034147 | 40 | 58 | | 8 | |
| FSE0005FB | 40*58*8 TC(VITON) | | 40 | 58 | | 8 | |
| FSE0755NB | 40*58*8/11.5 HTC9R | 91206-PX5-003/5 | 40 | 58 | | 8 | 11.5 |
| FSE0695NB | 40*58*8.5 TC | | 40 | 58 | | 8.5 | |
| FSE0703NB | 40*58*9 TC | | 40 | 58 | | 9 | |
| FSE0210NB | 40*58*10 HTGL | 24 11 1 218 009A | 40 | 58 | | 10 | |

| WLK CODE | OIL SEALS | DESCRIPTION | ID | OD1 | OD2 | H1 | H2 |
|-----------|--|----------------------|-------|-------|-------|------|------|
| FSE0210FB | 40*58*10 HTGL (FKM) | 24 11 1 218 009A | 40 | 58 | | 10 | |
| FSE0004NB | 40*58*10 TC | 09283-40028 | 40 | 58 | | 10 | |
| FSE0004FB | 40*58*10 TC(VITON) | | 40 | 58 | | 10 | |
| FSE0004QB | 40*58*10 TC(VMQ) | | 40 | 58 | | 10 | |
| FSE0826NB | 40*58*10.5 DC | | 40 | 58 | | 10.5 | |
| FSE0876NB | 40*58*12 TC | | 40 | 58 | | 12 | |
| FSE0933NB | 41*58*9/12.7 TB9Y Blue Painting | ID-2MM | 41 | 58 | | 9 | 12.7 |
| FSE0770NB | 42*58*7 KB | | 42 | 58 | | 7 | |
| FSE0758NB | 42*58*7 TB | | 42 | 58 | | 7 | |
| FSE0361NB | 42*58*7 TC | | 42 | 58 | | 7 | |
| FSE0003NB | 42*58*8 TC | TS50 CRANK SHAFT | 42 | 58 | | 8 | |
| FSE0003FB | 42*58*8 TC(VITON) | | 42 | 58 | | 8 | |
| FSE0901NB | 42*58*9 HTGR | | 42 | 58 | | 9 | |
| FSE1105NB | 42*58*9/16 TG9W2 | | 42 | 58 | | 9 | 16 |
| FSE0772N0 | 42*58*10 KC3A | W/Greased | 42 | 58 | | 10 | |
| FSC0941NB | 42*58*10 SB | | 42 | 58 | | 10 | |
| FSE0797NB | 42*58*10 SC | | 42 | 58 | | 10 | |
| FSE0308NB | 42*58*10 TC | | 42 | 58 | | 10 | |
| FSE0219QB | 43*58*7 HSBR (VMQ) BROWN | 004 99 72 747 | 43 | 58 | | 7 | |
| FSE0219NB | 43*58*7 HSCBR | 004 99 72 747 | 43 | 58 | | 7 | |
| FSE0766NB | 43*58*7 HSGBR | | 43 | 58 | | 7 | |
| FSE0550NB | 43*58*7 TC | | 43 | 58 | | 7 | |
| FSE0917NB | 43*58*8 TC | | 43 | 58 | | 8 | |
| FSE0546NB | 44*58*7 SB | | 44 | 58 | | 7 | |
| FSE0487NB | 44*58*8 TC | | 44 | 58 | | 8 | |
| FSE0778NB | 44*58*9 TC | | 44 | 58 | | 9 | |
| FSE0792NB | 45*58*4 TC | | 45 | 58 | | 4 | |
| FSE0949NB | 45*58*6/6.5 TCV | | 45 | 58 | | 6 | 6.5 |
| FSE0764NB | 45*58*7 SC | | 45 | 58 | | 7 | |
| FSE0764FB | 45*58*7 SC(VITON) | | 45 | 58 | | 7 | |
| FSE0313NB | 45*58*7 TC | | 45 | 58 | | 7 | |
| FSE0808NB | 45*58*7 TC4(BROWN) | | 45 | 58 | | 7 | |
| FSE0002NB | 45*58*8 TC4 | | 45 | 58 | | 8 | |
| FSE0222NB | 45*58*9 TB | MB-001314,MB-393719 | 45 | 58 | | 9 | |
| FSE0565NB | 45*58*9 TC | | 45 | 58 | | 9 | |
| FSE0786NB | 45*58*12 TC | | 45 | 58 | | 12 | |
| FSE0499NB | 46*58*7 HTCR | 1351040F00/10 | 46 | 58 | | 7 | |
| FSE0499QB | 46*58*7 HTCR(VMQ) | | 46 | 58 | | 7 | |
| FSE0646NB | 46*58*8 HTCR | | 46 | 58 | | 8 | |
| FSE0108N0 | 47*58*7 KC | | 47 | 58 | | 7 | |
| FSE0816NB | 47*58*7 TC | | 47 | 58 | | 7 | |
| FSE0964NB | 47*58*10 TC | | 47 | 58 | | 10 | |
| FSE0798NB | 48*58*4 TC | | 48 | 58 | | 4 | |
| FSE0613NB | 48*58*5 SB | | 48 | 58 | | 5 | |
| FSE0094NB | 48*58*5 TC | | 48 | 58 | | 5 | |
| FSE0561NB | 48*58*6 SB | | 48 | 58 | | 6 | |
| FSE0341NB | 48*58*7 SB(SM) | | 48 | 58 | | 7 | |
| FSE0935NB | 48*58*7 TC | | 48 | 58 | | 7 | |
| FSE0861NB | 48*58*8 TC | | 48 | 58 | | 8 | |
| FSE0524NB | 48*58*10 TC | | 48 | 58 | | 10 | |
| FSE0875NB | 50*58*4 TC | | 50 | 58 | | 4 | |
| FSE0741NB | 50*58*4 VB | | 50 | 58 | | 4 | |
| FSE0863NB | 50*58*4.5 SC | | 50 | 58 | | 4.5 | |
| FSE0076N0 | 50*58*8 KB4 | | 50 | 58 | | 8 | |
| FSE0180N0 | 51*58*4 VB | | 51 | 58 | | 4 | |
| FSE0083NB | 33.09*58.03*6.08 VA | 1.303*2.285*0.239 VA | 33.09 | 58.03 | | 6.08 | |
| FSE9921NB | 35.53*58.17/63.91*12.7 TB5Y Green Painting | | 35.53 | 58.17 | 63.91 | 12.7 | |

| WLK CODE | OIL SEALS | DESCRIPTION | ID | OD1 | OD2 | H1 | H2 |
|-----------|--|-----------------------|-------|-------|-------|-------|------|
| FSE9905NB | 40.01*58.17/64.1*9.14TB5 | 15750N | 40.01 | 58.17 | 64.1 | 9.14 | |
| FSE0052NB | 35.53*58.21*11.68 SBP | 1.399*2.292*0.460 SBP | 35.53 | 58.21 | | 11.68 | |
| FSE9904NB | 35.53*58.21*13.2 TB | | 35.53 | 58.21 | | 13.2 | |
| FSE9909NB | 35.53*58.22*11.7 SB | | 35.53 | 58.22 | | 11.7 | |
| FSE9920NB | 35.53*58.22/69.85*13.89 DB5 | OD W/sealant | 35.53 | 58.22 | 69.85 | 13.89 | |
| FSE0652NB | 45*58.5/63*5/9 KB59 | | 45 | 58.5 | 63 | 5 | 9 |
| FSE9916NB | 39.7*58.75*9.52 TC | | 39.7 | 58.75 | | 9.52 | |
| FSD0521NB | 33*59*11/17 TC9 | 38342-03E01 | 33 | 59 | | 11 | 17 |
| FSE0001NB | 37*59*9 TC6 | | 37 | 59 | | 9 | |
| FSE0924NB | 38*59*8 TC | | 38 | 59 | | 8 | |
| FSE0884NB | 38*59*9 HTCR | | 38 | 59 | | 9 | |
| FSE0089NB | 38*59*9 TC | | 38 | 59 | | 9 | |
| FSE0390NB | 39*59*11/17 TC9 | 38342-03E00 | 39 | 59 | | 11 | 17 |
| FSE0881NB | 40*59*5.5 TB | | 40 | 59 | | 5.5 | |
| FSE0490NB | 41*59*10/15 HTC9R | 90311-41008 | 41 | 59 | | 10 | 15 |
| FSE0984NB | 42*59*7.7 HSCR | | 42 | 59 | | 7.7 | |
| FSE0854NB | 43*59*8 TC | | 43 | 59 | | 8 | |
| FSE0534AB | 44*59*6.8 HSCR (PA)ACM | | 44 | 59 | | 6.8 | |
| FSE1085NB | 45*59*7 TC | | 45 | 59 | | 7 | |
| FSE0410N0 | 45*59*8 VCK5Y W/Felt | 09284-45001 | 45 | 59 | | 8 | |
| FSE0860NB | 45*59*10 TC | | 45 | 59 | | 10 | |
| FSE0862NB | 46*59*12 TC | | 46 | 59 | | 12 | |
| FSF0801NB | 41.68*59.1*7.75 HSCR | NISSAN SENTRA 200SX | 41.68 | 59.1 | | 7.75 | |
| FSE0737NB | 46*59.1*12/13 KC | | 46 | 59.1 | | 12 | 13 |
| FSE0258NB | 37.49*59.13*10.01 TBP | 1.476*2.328*0.394 TBP | 37.49 | 59.13 | | 10.01 | |
| FSE0404NB | 37.85*59.13*9.53 TCU | | 37.85 | 59.13 | | 9.53 | |
| FSE0079NB | 37.85*59.13*9.83 TB | 1.490*2.328*0.387 TB | 37.85 | 59.13 | | 9.83 | |
| FSE0215NB | 41.28*59.13*9.86 SB | 1.625*2.328*0.388 SB | 41.28 | 59.13 | | 9.86 | |
| FSE0193N0 | 42.88*59.13*12.7 VB5 | 1.688*2.328*0.500 VB5 | 42.88 | 59.13 | | 12.7 | |
| FSE9903NB | 44.04*59.13/66.8*7.95 VB5 Green Painting | | 44.04 | 59.13 | 66.8 | 7.95 | |
| FSE0259NB | 44.50*59.13*10.01 SBP | 1.752*2.328*0.394 SBP | 44.5 | 59.13 | | 10.01 | |
| FSE9899NB | 45.95*59.97/72.82*9.53 KB59 | | 45.95 | 59.97 | 72.82 | 9.53 | |
| FSE0939NB | 25*60*7 TC | | 25 | 60 | | 7 | |
| FSE0830NB | 25*60*8 TC | | 25 | 60 | | 8 | |
| FSE0338NB | 25*60*10 TC | | 25 | 60 | | 10 | |
| FSE0996NB | 28*60*10 TC | | 28 | 60 | | 10 | |
| FSE0266NB | 30*60*7 TC | | 30 | 60 | | 7 | |
| FSE0331NB | 30*60*8 TC | ACESIL商標 | 30 | 60 | | 8 | |
| FSE0402NB | 30*60*10 TB | | 30 | 60 | | 10 | |
| FSE0276NB | 30*60*10 TC | | 30 | 60 | | 10 | |
| FSE0285NB | 32*60*8 TC | | 32 | 60 | | 8 | |
| FSE1093NB | 32*60*10 SB | | 32 | 60 | | 10 | |
| FSE0286NB | 32*60*10 TC | | 32 | 60 | | 10 | |
| FSE0201N0 | 35*60*5 VC | | 35 | 60 | | 5 | |
| FSE0535NB | 35*60*7 TC | | 35 | 60 | | 7 | |
| FSE0673NB | 35*60*8 TC | | 35 | 60 | | 8 | |
| FSE0239NB | 35*60*10 SC | | 35 | 60 | | 10 | |
| FSE0289NB | 35*60*10 TC | | 35 | 60 | | 10 | |
| FSE0289FB | 35*60*10 TC(VITON) | | 35 | 60 | | 10 | |
| FSE0238NB | 35*60*12 TC | | 35 | 60 | | 12 | |
| FSE0492NB | 36*60*7 TC | | 36 | 60 | | 7 | |
| FSD0672NB | 36*60*8 TC | | 36 | 60 | | 8 | |
| FSE0240NB | 36*60*10 DGS (ACM) | | 36 | 60 | | 10 | |
| FSE0725NB | 38*60*7 TC | | 38 | 60 | | 7 | |
| FSE0242NB | 38*60*8 TC | 29971-80050 | 38 | 60 | | 8 | |
| FSE0242FB | 38*60*8 TC(VITON) | | 38 | 60 | | 8 | |
| FSE0689NB | 38*60*8/14.5 TC9 | 29971-80050/51 | 38 | 60 | | 8 | 14.5 |

| WLK CODE | OIL SEALS | DESCRIPTION | ID | OD1 | OD2 | H1 | H2 |
|-----------|--------------------------|--------------------------|------|-----|-----|------|------|
| FSE0630NB | 38*60*9 TC | | 38 | 60 | | 9 | |
| FSE0660NB | 38*60*10 SC | | 38 | 60 | | 10 | |
| FSE0295NB | 38*60*10 TC | | 38 | 60 | | 10 | |
| FSE0578NB | 38*60*11 TC(Brown) | | 38 | 60 | | 11 | |
| FSE1100NB | 38*60*12 SC | | 38 | 60 | | 12 | |
| FSE0979NB | 39*60*8 TC | | 39 | 60 | | 8 | |
| FSE0960NB | 39*60*10 TB | | 39 | 60 | | 10 | |
| FSE0721NB | 39.5*60*10 TB | 9-09624-035-0 | 39.5 | 60 | | 10 | |
| FSE0189N0 | 40*60*5 VC | | 40 | 60 | | 5 | |
| FSE0322NB | 40*60*7 SC | | 40 | 60 | | 7 | |
| FSE0304NB | 40*60*7 TC | | 40 | 60 | | 7 | |
| FSE0304QB | 40*60*7 TC(VMQ) | | 40 | 60 | | 7 | |
| FSE1091NB | 40*60*7 TZ | | 40 | 60 | | 7 | |
| FSE0943NB | 40*60*7/10 GA | | 40 | 60 | | 7 | 10 |
| FSE0243NB | 40*60*8 TC | | 40 | 60 | | 8 | |
| FSE0243FB | 40*60*8 TC(VITON) | | 40 | 60 | | 8 | |
| FSE0244NB | 40*60*9 TB | | 40 | 60 | | 9 | |
| FSE0879FB | 40*60*10 SC(VITON) | TC修掉副唇 | 40 | 60 | | 10 | |
| FSE0557NB | 40*60*10 TB3 | 5-09625-092-0 | 40 | 60 | | 10 | |
| FSE0236NB | 40*60*10 TC | 03AT67 | 40 | 60 | | 10 | |
| FSE0236QB | 40*60*10 TC (VMQ) | | 40 | 60 | | 10 | |
| FSE0236NS | 40*60*10 TC(S304 SPRING) | | 40 | 60 | | 10 | |
| FSE0236FB | 40*60*10 TC(VITON)FKM | | 40 | 60 | | 10 | |
| FSE0235NB | 40*60*12 TC | | 40 | 60 | | 12 | |
| FSE0617NB | 40*60*12 TCN(NBR905) | AP2378F | 40 | 60 | | 12 | |
| FSE0246NB | 40.2*60*8/10.5 TGY(TCY) | Electrolux, Tricity Bend | 40.2 | 60 | | 8 | 10.5 |
| FSE0693NB | 40.2*60/105*8/15.5 VGA5Y | 03AT88兩個組合 | 40.2 | 60 | 105 | 8 | 15.5 |
| FSE0072NB | 40.2*60/86*10.5/16 Y | ELECTROLUX, TRICITY | 40.2 | 60 | 86 | 10.5 | 16 |
| FSE0588NB | 41*60*7 HTCR(Brown) | | 41 | 60 | | 7 | |
| FSE0902NB | 42*60*6 KC | | 42 | 60 | | 6 | |
| FSE0247NB | 42*60*7 HTCR | 90311-42007/3/42012 | 42 | 60 | | 7 | |
| FSE0247QB | 42*60*7 HTCR(VMQ) | | 42 | 60 | | 7 | |
| FSE0623NB | 42*60*7 HTZR | BROWN | 42 | 60 | | 7 | |
| FSE0379NB | 42*60*7 SM | SEB | 42 | 60 | | 7 | |
| FSE0309NB | 42*60*7 TC | 91252-634-003 | 42 | 60 | | 7 | |
| FSE0309FB | 42*60*7 TC(VITON) | | 42 | 60 | | 7 | |
| FSE0310NB | 42*60*8 TC | | 42 | 60 | | 8 | |
| FSE0231NB | 42*60*9 HTCR | 90311-42001/14 | 42 | 60 | | 9 | |
| FSE0231QB | 42*60*9 HTCR (VMQ) | | 42 | 60 | | 9 | |
| FSE1102NB | 42*60*9 HTZR(Red) | | 42 | 60 | | 9 | |
| FSE0396NB | 42*60*9 TB | | 42 | 60 | | 9 | |
| FSE0229NB | 42*60*9 TC | NM75 曲軸 | 42 | 60 | | 9 | |
| FSE0749NB | 42*60*10 SC | | 42 | 60 | | 10 | |
| FSE0248NB | 42*60*10 TC | | 42 | 60 | | 10 | |
| FSE0657NB | 42*60*12 SC | | 42 | 60 | | 12 | |
| FSF0659NB | 42*60*12 TC | | 42 | 60 | | 12 | |
| FSE1098FB | 43*60*7.5 HTCR(VITON) | | 43 | 60 | | 7.5 | |
| FSE0889QB | 43*60*8 TB(VMQ) | | 43 | 60 | | 8 | |
| FSE0250NB | 43*60*9 HTCL | | 43 | 60 | | 9 | |
| FSE0990NB | 43*60*10 SC | | 43 | 60 | | 10 | |
| FSE0362NB | 43*60*10 TC | | 43 | 60 | | 10 | |
| FSE0362FB | 43*60*10 TC(VITON) | | 43 | 60 | | 10 | |
| FSE0784NB | 43*60*12 SB | AB2540E | 43 | 60 | | 12 | |
| FSE0334NB | 44*60*7 HTCR | MD-008882, MD-050606 | 44 | 60 | | 7 | |
| FSE0334QB | 44*60*7 HTCR(VMQ) | 61505 | 44 | 60 | | 7 | |
| FSE0363NB | 44*60*7 TC | | 44 | 60 | | 7 | |

| WLK CODE | OIL SEALS | DESCRIPTION | ID | OD1 | OD2 | H1 | H2 |
|-----------|------------------------|------------------|----|-----|-----|-----|----|
| FSE0252QB | 44*60*8 SB(VMQ) | 白,綠噴漆 | 44 | 60 | | 8 | |
| FSE0704NB | 44*60*8 SC | | 44 | 60 | | 8 | |
| FSE0814NB | 44*60*8 TC | | 44 | 60 | | 8 | |
| FSE0234NB | 44*60*9 HTCR | | 44 | 60 | | 9 | |
| FSE0228NB | 44*60*9 TC | TS60 CRANK SHAFT | 44 | 60 | | 9 | |
| FSE0227NB | 44*60*9.5 SC | | 44 | 60 | | 9.5 | |
| FSE0944NB | 44*60*10 SC | | 44 | 60 | | 10 | |
| FSE0707NB | 44*60*10 TC | | 44 | 60 | | 10 | |
| FSE0707FB | 44*60*10 TC(FKM)VITON | | 44 | 60 | | 10 | |
| FSE0407NB | 45*60*5 VC | | 45 | 60 | | 5 | |
| FSE0915NB | 45*60*6 HTCL(BRWON) | | 45 | 60 | | 6 | |
| FSE0226NB | 45*60*6 SC | | 45 | 60 | | 6 | |
| FSF0203N0 | 45*60*6 VB | 3ES C.W. PUMP | 45 | 60 | | 6 | |
| FSE0597NB | 45*60*7 SC | 03AT50 | 45 | 60 | | 7 | |
| FSE0597FB | 45*60*7 SC(VITON) | | 45 | 60 | | 7 | |
| FSE0253NB | 45*60*7 TC | | 45 | 60 | | 7 | |
| FSE0253FU | 45*60*7 TC (VITON)S316 | SUS316 SPRING | 45 | 60 | | 7 | |
| FSE0253QB | 45*60*7 TC (VMQ) | | 45 | 60 | | 7 | |
| FSE0254NB | 45*60*8 DGS(HTG) | 018 409 399 | 45 | 60 | | 8 | |
| FSE0972FB | 45*60*8 SC(VITON) | | 45 | 60 | | 8 | |
| FSE0928NB | 45*60*8 SM(SB) | | 45 | 60 | | 8 | |
| FSE0315NB | 45*60*8 TC | | 45 | 60 | | 8 | |
| FSE0315FB | 45*60*8 TC(VITON) | | 45 | 60 | | 8 | |
| FSE0233NB | 45*60*9 HTCR | 806745081 | 45 | 60 | | 9 | |
| FSE0672NB | 45*60*9 TB | | 45 | 60 | | 9 | |
| FSE0255NB | 45*60*9 TC | 44514-51681 | 45 | 60 | | 9 | |
| FSE0255FB | 45*60*9 TC(VITON) | | 45 | 60 | | 9 | |
| FSE1109FB | 45*60*10 SC(VITON) | | 45 | 60 | | 10 | |
| FSE0656NB | 45*60*10 SEC4 | ACESIL商標 | 45 | 60 | | 10 | |
| FSE0230NB | 45*60*10 TC | | 45 | 60 | | 10 | |
| FSE0263NB | 45*60*12 TC | | 45 | 60 | | 12 | |
| FSE0768NB | 46*60*7 HTCR | | 46 | 60 | | 7 | |
| FSF0355NB | 46*60*7 TC | | 46 | 60 | | 7 | |
| FSF0438NB | 46*60*10 TC | | 46 | 60 | | 10 | |
| FSF0777NB | 46*60*10/16 TC9 | | 46 | 60 | | 10 | 16 |
| FSE0762NB | 47*60*7 TC | | 47 | 60 | | 7 | |
| FSE0811NB | 47*60*8 TC | | 47 | 60 | | 8 | |
| FSE0591NB | 48*60*5 SB | | 48 | 60 | | 5 | |
| FSE0777NB | 48*60*7 TC | | 48 | 60 | | 7 | |
| FSE0777FB | 48*60*7 TC(VITON)FKM | | 48 | 60 | | 7 | |
| FSE0529NB | 48*60*8 TB | | 48 | 60 | | 8 | |
| FSE0571NB | 48*60*8 TC | | 48 | 60 | | 8 | |
| FSE0257NB | 48*60*9 HTBR | 9828-48102 | 48 | 60 | | 9 | |
| FSE0392NB | 48*60*9 TB | | 48 | 60 | | 9 | |
| FSE0821NB | 48*60*9 TC | | 48 | 60 | | 9 | |
| FSE0801NB | 48*60*10 TC | | 48 | 60 | | 10 | |
| FSE1104NB | 48*60*12 TC | | 48 | 60 | | 12 | |
| FSE0661NB | 49*60*10 TC4 | | 49 | 60 | | 10 | |
| FSE0962NB | 50*60*5 TC(BLUE) | | 50 | 60 | | 5 | |
| FSE0515N0 | 50*60*5/8 TDKI(GA) | | 50 | 60 | | 5 | 8 |
| FSE0767NB | 50*60*6 KC | | 50 | 60 | | 6 | |
| FSE1097NB | 50*60*6 TC | | 50 | 60 | | 6 | |
| FSE1097FB | 50*60*6 TC(VITON) | | 50 | 60 | | 6 | |
| FSE0799NB | 50*60*7 SC | | 50 | 60 | | 7 | |
| FSE0587NB | 50*60*7 TC | | 50 | 60 | | 7 | |
| FSE0587FB | 50*60*7 TC(VITON) | | 50 | 60 | | 7 | |
| FSE0705NB | 50*60*7 TZ | | 50 | 60 | | 7 | |

| WLK CODE | OIL SEALS | DESCRIPTION | ID | OD1 | OD2 | H1 | H2 |
|-----------|--|----------------------|-------|--------|-------|-------|-------|
| FSE0662NB | 50*60/63*7/13 Y | | 50 | 60 | 63 | 7 | 13 |
| FSE0317NB | 50*60*8 TC | | 50 | 60 | | 8 | |
| FSE0317FB | 50*60*8 TC(VITON) | | 50 | 60 | | 8 | |
| FSE0951NB | 50*60*10 SC | | 50 | 60 | | 10 | |
| FSE0585NB | 50*60*10 TB | | 50 | 60 | | 10 | |
| FSE0907NB | 50*60*10 TC | | 50 | 60 | | 10 | |
| FSF0368NB | 44.5*60.03*9.5 TC | | 44.5 | 60.03 | | 9.5 | |
| FSE0249NB | 42.8*60.3*10 TC | | 42.8 | 60.3 | | 10 | |
| FSF9870NB | 44.45*60.3*11.13 SB | 5539 | 44.45 | 60.3 | | 11.13 | |
| FSF9980NB | 44.5*60.30*9.5 TC | FORD | 44.5 | 60.3 | | 9.5 | |
| FSF9997NB | 38.1*60.32*9.52 TC | | 38.1 | 60.32 | | 9.52 | |
| FSF0552NB | 38.1*60.32*12.7 TCW | | 38.1 | 60.32 | | 12.7 | |
| FSF9936NB | 44.45*60.32*7.93 SC | | 44.45 | 60.32 | | 7.93 | |
| FSD0451NB | 38.89*60.325*12.7 DC | 1.531*2.375*0.500 DC | 38.89 | 60.325 | | 12.7 | |
| FSF9921NB | 31.75*60.33*9.53 TC | | 31.75 | 60.33 | | 9.53 | |
| FSF9922NB | 31.75*60.33*12.7 TC | | 31.75 | 60.33 | | 12.7 | |
| FSF9898NB | 34.92*60.33*7.95 TB | | 34.92 | 60.33 | | 7.95 | |
| FSF9938NB | 34.92*60.33*12.7 SC | | 34.92 | 60.33 | | 12.7 | |
| FSF9891NB | 34.93*60.33*7.95 TC | | 34.93 | 60.33 | | 7.95 | |
| FSF9840NB | 34.93*60.33*9.53 TC | | 34.93 | 60.33 | | 9.53 | |
| FSE0179N0 | 38.1*60.33*6.35 KC | 495-630 | 38.1 | 60.33 | | 6.35 | |
| FSF9977NB | 38.1*60.33*6.35 TB | | 38.1 | 60.33 | | 6.35 | |
| FSF0559N0 | 38.10*60.33*6.35 KC | | 38.1 | 60.33 | | 6.35 | |
| FSF9933NB | 38.1*60.33*7.95 TB | | 38.1 | 60.33 | | 7.95 | |
| FSF9933FB | 38.1*60.33*7.95 TB(FKM) | VITON | 38.1 | 60.33 | | 7.95 | |
| FSF9877NB | 38.1*60.33*9.53 SC | | 38.1 | 60.33 | | 9.53 | |
| FSF9972NB | 38.1*60.33*9.53 TB | | 38.1 | 60.33 | | 9.53 | |
| FSF9852NB | 38.1*60.33*11.91/16.66 TBAY w/felt | | 38.1 | 60.33 | | 11.91 | 16.66 |
| FSF9812NB | 38.1*60.33*12.7 SC | | 38.1 | 60.33 | | 12.7 | |
| FSF9913NB | 38.1*60.33*12.7 TCW | | 38.1 | 60.33 | | 12.7 | |
| FSF9910NB | 38.1*60.33*12.7 Y | | 38.1 | 60.33 | | 12.7 | |
| FSF9861NB | 39.7*60.33*7.95 TC | | 39.7 | 60.33 | | 7.95 | |
| FSF9815NB | 39.7*60.33*9.53 TC | | 39.7 | 60.33 | | 9.53 | |
| FSF9970NB | 41.28*60.33*7.95 TB | | 41.28 | 60.33 | | 7.95 | |
| FSF9871NB | 41.28*60.33*9.53 SB | | 41.28 | 60.33 | | 9.53 | |
| FSF9915NB | 41.28*60.33*9.53 TB | | 41.28 | 60.33 | | 9.53 | |
| FSF9944NB | 41.28*60.33*9.53 TC | 1.625*2.375*0.375 | 41.28 | 60.33 | | 9.53 | |
| FSF9931FB | 41.28*60.33*12.7 TA(FKM) | VITON | 41.28 | 60.33 | | 12.7 | |
| FSF9902NB | 41.28*60.33*12.7 TB | | 41.28 | 60.33 | | 12.7 | |
| FSF9876NB | 43.66*60.33*9.53 TC | | 43.66 | 60.33 | | 9.53 | |
| FSF9925NB | 44.45*60.33*6.35 TB | | 44.45 | 60.33 | | 6.35 | |
| FSF9929NB | 44.45*60.33*7.95 TB | | 44.45 | 60.33 | | 7.95 | |
| FSF9966NB | 44.45*60.33*9.53 TC | 1.750*2.375*0.375 | 44.45 | 60.33 | | 9.53 | |
| FSF0818N0 | 50.8*60.33*4.78 VB | | 50.8 | 60.33 | | 4.78 | |
| FSF9827NB | 50.8*60.33*6.35 SC | | 50.8 | 60.33 | | 6.35 | |
| FSF9884NB | 38.1*60.35/67.27*11.68/18.06 HTB59L | | 38.1 | 60.35 | 67.27 | 11.68 | 18.06 |
| FSF9883NB | 38.1*60.37/65.48*12.29 HTB5L Blue Painting | | 38.1 | 60.37 | 65.48 | 12.29 | |
| FSF0095NB | 37*60.5*12.5 DC | | 37 | 60.5 | | 12.5 | |
| FSF0201N0 | 35*61*6 VC | | 35 | 61 | | 6 | |
| FSF0366NB | 37*61*10/14 HTBCR9 | | 37 | 61 | | 10 | 14 |
| FSF0913NB | 40*61*8 TC | | 40 | 61 | | 8 | |
| FSF0736NB | 40*61*12 TC | | 40 | 61 | | 12 | |
| FSF0094NB | 41*61*5 VA(P5598) | | 41 | 61 | | 5 | |
| FSF0856NB | 41*61*9 TB | | 41 | 61 | | 9 | |
| FSF0849NB | 41*61*9/13.5 HTC9W | Mitsubishi Lancer | 41 | 61 | | 9 | 13.5 |
| FSF0836NB | 41*61*10 TC | | 41 | 61 | | 10 | |
| FSF0613NB | 41*61*10/15 HTC9L | | 41 | 61 | | 10 | 15 |

| WLK CODE | OIL SEALS | DESCRIPTION | ID | OD1 | OD2 | H1 | H2 |
|-----------|--------------------------|-----------------------|-------|-------|-----|------|-----|
| FSF0093NB | 45*61*9 TC | | 45 | 61 | | 9 | |
| FSF9835NB | 44.86*61.11*9.53 HTBR | | 44.86 | 61.11 | | 9.53 | |
| FSF9904NB | 44.86*61.11*9.53 VBP | | 44.86 | 61.11 | | 9.53 | |
| FSF0159NB | 42*61.33*15.7 TA | | 42 | 61.33 | | 15.7 | |
| FSF9896NB | 38.1*61.93*9.53 SC | | 38.1 | 61.93 | | 9.53 | |
| FSF9890NB | 41.28*61.93*7.95 TB | | 41.28 | 61.93 | | 7.95 | |
| FSF9825FB | 44.45*61.93*7.95 TB(FKM) | VITON | 44.45 | 61.93 | | 7.95 | |
| FSF9814NB | 44.45*61.93*7.95 TC | | 44.45 | 61.93 | | 7.95 | |
| FSF9935NB | 44.45*61.93*9.53 TC | | 44.45 | 61.93 | | 9.53 | |
| FSF0197NB | 44.45*61.98*9.53 TB | 1.750*2.440*0.375 TB | 44.45 | 61.98 | | 9.53 | |
| FSF0092NB | 20*62*6.5 SC | 1100354 | 20 | 62 | | 6.5 | |
| FSF0654NB | 20*62*10 TC | | 20 | 62 | | 10 | |
| FSF0813NB | 22*62*7 SC | | 22 | 62 | | 7 | |
| FSF0168QB | 23*62*8 HSB (VMQ) | CP-MATIC GERMANY | 23 | 62 | | 8 | |
| FSE0345NB | 24*62*7 TC | | 24 | 62 | | 7 | |
| FSF0129NB | 25*62*7 TC | | 25 | 62 | | 7 | |
| FSF0305NB | 25*62*8 TC | | 25 | 62 | | 8 | |
| FSF0305QB | 25*62*8 TC(VMQ) | | 25 | 62 | | 8 | |
| FSF0091NB | 25*62*10 TC | | 25 | 62 | | 10 | |
| FSF0090NB | 25*62*12 SA | | 25 | 62 | | 12 | |
| FSF0577NB | 26*62*9 TC | | 26 | 62 | | 9 | |
| FSF0730NB | 27*62*10 TC | | 27 | 62 | | 10 | |
| FSF0578NB | 28*62*7 TC | | 28 | 62 | | 7 | |
| FSF0375NB | 28*62*10 TC | | 28 | 62 | | 10 | |
| FSF0371NB | 28*62*10/12 TG4 | 17-2692Z9 | 28 | 62 | | 10 | 12 |
| FSF0814NB | 30*62*5 TC | | 30 | 62 | | 5 | |
| FSF0592NB | 30*62*6 SB | | 30 | 62 | | 6 | |
| FSF0863NB | 30*62*7 SC | | 30 | 62 | | 7 | |
| FSF0921FB | 30*62*7 SC(VITON) | TC修掉副唇 | 30 | 62 | | 7 | |
| FSF0103NB | 30*62*7 TC | | 30 | 62 | | 7 | |
| FSF0103FB | 30*62*7 TC(VITON) | | 30 | 62 | | 7 | |
| FSF0135NB | 30*62*8 TB(TBP) | | 30 | 62 | | 8 | |
| FSF0134NB | 30*62*8 TB4 | | 30 | 62 | | 8 | |
| FSF0089NB | 30*62*8 TC | | 30 | 62 | | 8 | |
| FSF0089FB | 30*62*8 TC(VITON) | | 30 | 62 | | 8 | |
| FSF0631NB | 30*62*9 TC | | 30 | 62 | | 9 | |
| FSF0486NB | 30*62/69*9.5/16 TG59Y | | 30 | 62 | 69 | 9.5 | 16 |
| FSF0088NB | 30*62*10 SC | | 30 | 62 | | 10 | |
| FSF0125NB | 30*62*10 TC | | 30 | 62 | | 10 | |
| FSF0125FB | 30*62*10 TC(VITON) | | 30 | 62 | | 10 | |
| FSF0504N0 | 30*62*10/12 KCY | | 30 | 62 | | 10 | 12 |
| FSF0087NB | 30*62*11 TC | | 30 | 62 | | 11 | |
| FSF0335NB | 30*62*12 SC | | 30 | 62 | | 12 | |
| FSF0658NB | 30*62*12 TC | | 30 | 62 | | 12 | |
| FSF0086NB | 31*62*4/5.5 SC | | 31 | 62 | | 4 | 5.5 |
| FSF0352NB | 32*62*7 TC | | 32 | 62 | | 7 | |
| FSF0530NB | 32*62*8 TC | | 32 | 62 | | 8 | |
| FSF0530FB | 32*62*8 TC(VITON) | | 32 | 62 | | 8 | |
| FSF0085NB | 32*62*10 SA | | 32 | 62 | | 10 | |
| FSF0380NB | 32*62*10 TC | | 32 | 62 | | 10 | |
| FSF0380FB | 32*62*10 TC(VITON) | | 32 | 62 | | 10 | |
| FSF0192NB | 32*62*12 DCY | | 32 | 62 | | 12 | |
| FSF0585NB | 32*62*12 SC | | 32 | 62 | | 12 | |
| FSF0733NB | 33*62*10 SC | | 33 | 62 | | 10 | |
| FSF0450NB | 34*62*8 TC | | 34 | 62 | | 8 | |
| FSF0419NB | 34*62*10 TC | | 34 | 62 | | 10 | |
| FSF0096NB | 34.93*62*7.95 TBP | 1.375*2.441*0.313 TBP | 34.93 | 62 | | 7.95 | |

| WLK CODE | OIL SEALS | DESCRIPTION | ID | OD1 | OD2 | H1 | H2 |
|-----------|-----------------------------|--------------------------|------|-----|------|------|------|
| FSF0471NB | 35*62*6 TC | | 35 | 62 | | 6 | |
| FSF0084NB | 35*62*7 SC | | 35 | 62 | | 7 | |
| FSF0084FB | 35*62*7 SC(VITON) | | 35 | 62 | | 7 | |
| FSF0859FB | 35*62*7 TB(VITON) | | 35 | 62 | | 7 | |
| FSF0383NB | 35*62*7 TC | | 35 | 62 | | 7 | |
| FSF0383FB | 35*62*7 TC(VITON) | | 35 | 62 | | 7 | |
| FSF0383QB | 35*62*7 TC(VMQ) | | 35 | 62 | | 7 | |
| FSF0083NB | 35*62*7/13 TC6 | 三菱2850尾輪輪下 | 35 | 62 | | 7 | 13 |
| FSF0495NB | 35*62*7/7.5 TCV NBR80 Brown | | 35 | 62 | | 7 | 7.5 |
| FSF0300NB | 35*62/75*7/10 TGY | Ariston A1100UK/1124UK u | 35 | 62 | 75 | 7 | 10 |
| FSF0297NB | 35*62/78.5*7.5/10.5 TGA5 | Ariston, Creda, Indesit, | 35 | 62 | 78.5 | 7.5 | 10.5 |
| FSF0140NB | 35*62*8 SC | | 35 | 62 | | 8 | |
| FSF0118NB | 35*62*8 TC | | 35 | 62 | | 8 | |
| FSF0118FB | 35*62*8 TC(FKM)VITON | | 35 | 62 | | 8 | |
| FSF0781NB | 35*62*8/11.5 HTC9L | 91205-689-003 | 35 | 62 | | 8 | 11.5 |
| FSF0315NB | 35*62*9 TC | | 35 | 62 | | 9 | |
| FSF0315FB | 35*62*9 TC(VITON) | | 35 | 62 | | 9 | |
| FSF0848NB | 35*62*9/12 TC9 | | 35 | 62 | | 9 | 12 |
| FSF0717NB | 35*62*9.5 TC | 09283-35024/5 | 35 | 62 | | 9.5 | |
| FSF0119NB | 35*62*10 KC3 | | 35 | 62 | | 10 | |
| FSF0860NB | 35*62*10 SB | | 35 | 62 | | 10 | |
| FSF0778NB | 35*62*10 TB | | 35 | 62 | | 10 | |
| FSF0082NB | 35*62*10 TC | 113LG26 | 35 | 62 | | 10 | |
| FSF0082AB | 35*62*10 TC(ACM) | | 35 | 62 | | 10 | |
| FSF0082FB | 35*62*10 TC(VITON) | | 35 | 62 | | 10 | |
| FSF0696NB | 35*62*10/12.5 KGAY | Aeg,Electrolux,Tricity B | 35 | 62 | | 10 | 12.5 |
| FSF0141NB | 35*62*10/16.5 TC9(TC7Y) | 09283-35008 | 35 | 62 | | 10 | 16.5 |
| FSF0536NB | 35*62*12 TC | | 35 | 62 | | 12 | |
| FSF0337NB | 36*62*7 SC | | 36 | 62 | | 7 | |
| FSF0337FB | 36*62*7 SC(VITON) | | 36 | 62 | | 7 | |
| FSF0425NB | 36*62*7 TC | | 36 | 62 | | 7 | |
| FSF0425FB | 36*62*7 TF(VITON) | | 36 | 62 | | 7 | |
| FSF0457NB | 36*62*8 TC | | 36 | 62 | | 8 | |
| FSF0712NB | 36*62*10 SB | | 36 | 62 | | 10 | |
| FSF0621NB | 36*62*10 TC | | 36 | 62 | | 10 | |
| FSF0128NB | 36*62*11/14 KC3Y | 6206 油封 | 36 | 62 | | 11 | 14 |
| FSF0426NB | 37*62*7 TC | | 37 | 62 | | 7 | |
| FSF0638NB | 37*62*8 SB | | 37 | 62 | | 8 | |
| FSF0569NB | 37*62*8 SC | | 37 | 62 | | 8 | |
| FSF0347NB | 37*62*8 TC | | 37 | 62 | | 8 | |
| FSF0823NB | 37*62*9 TC | | 37 | 62 | | 9 | |
| FSF0782NB | 37*62*10 SC | | 37 | 62 | | 10 | |
| FSF0479NB | 37*62*10 TC | | 37 | 62 | | 10 | |
| FSF0603NB | 37*62*10/12 TC9 | 90639-0005 | 37 | 62 | | 10 | 12 |
| FSF0898NB | 37*62*12 SC | | 37 | 62 | | 12 | |
| FSF0847NB | 37*62*12.5 TCA(TCEA) | | 37 | 62 | | 12.5 | |
| FSF0785NB | 37*62*12.5 Y | MB-092288, MB-837717 | 37 | 62 | | 12.5 | |
| FSF0284NB | 37*62*14 SC2Y(SCAY) | MB-092288 ; AC2206E | 37 | 62 | | 14 | |
| FSF0864NB | 37.4*62*10/12 TG69Y | | 37.4 | 62 | | 10 | 12 |
| FSF0427NB | 38*62*7 TC | | 38 | 62 | | 7 | |
| FSF0427FB | 38*62*7 TC(VITON) | | 38 | 62 | | 7 | |
| FSF0573NB | 38*62*7/8 KC | G001-25-744A | 38 | 62 | | 7 | 8 |
| FSF0591NB | 38*62*8 TC | | 38 | 62 | | 8 | |
| FSF0591FB | 38*62*8 TC(VITON) | | 38 | 62 | | 8 | |
| FSF0574NB | 38*62*9 TC | | 38 | 62 | | 9 | |
| FSF0387NB | 38*62*10 TC | | 38 | 62 | | 10 | |
| FSF0387FB | 38*62*10 TC(VITON) | | 38 | 62 | | 10 | |

| WLK CODE | OIL SEALS | DESCRIPTION | ID | OD1 | OD2 | H1 | H2 |
|-----------|----------------------------|---------------------|------|-----|------|------|------|
| FSF0502NB | 38*62*11 SC | | 38 | 62 | | 11 | |
| FSF0707NB | 38*62*11 TB | 43252-T3200 | 38 | 62 | | 11 | |
| FSF0533NB | 38*62*11 TC | | 38 | 62 | | 11 | |
| FSF0537NB | 38*62*12 TC | | 38 | 62 | | 12 | |
| FSD0518NB | 39.7*62*11 HTCR | 13042-B3000 | 39.7 | 62 | | 11 | |
| FSD0518QB | 39.7*62*11 HTCR(VMQ) | | 39.7 | 62 | | 11 | |
| FSF0200N0 | 40*62*5 VC | | 40 | 62 | | 5 | |
| FSF0941FB | 40*62*6 TC(VITON) | | 40 | 62 | | 6 | |
| FSF0307NB | 40*62*6 TCV(NBR80 Shore) | | 40 | 62 | | 6 | |
| FSF0827NB | 40*62*6/6.5 TCV | | 40 | 62 | | 6 | 6.5 |
| FSF0776NB | 40*62*6.5 KC | | 40 | 62 | | 6.5 | |
| FSF0589NB | 40*62*7 SC | | 40 | 62 | | 7 | |
| FSF0589FB | 40*62*7 SC (VITON) | | 40 | 62 | | 7 | |
| FSF0392NB | 40*62*7 TC | | 40 | 62 | | 7 | |
| FSF0392FB | 40*62*7 TC(VITON) | | 40 | 62 | | 7 | |
| FSF0392QB | 40*62*7 TC(VMQ) | | 40 | 62 | | 7 | |
| FSF0938FB | 40*62*8 SC(VITON) | TC修掉副唇 | 40 | 62 | | 8 | |
| FSF0081NB | 40*62*8 TC | TS50C/KND5B/GA80 曲軸 | 40 | 62 | | 8 | |
| FSF0081FB | 40*62*8 TC (FKM)VITON | | 40 | 62 | | 8 | |
| FSF0081QB | 40*62*8 TC(VMQ) | | 40 | 62 | | 8 | |
| FSF0629NB | 40*62*8/11.5 HTC9R Brown | 91205-PC9-711 | 40 | 62 | | 8 | 11.5 |
| FSF0349NB | 40*62/78*8/14.8 TG459Y | 1.07.003.07 | 40 | 62 | 78 | 8 | 14.8 |
| FSF0862FB | 40*62*9 SC(VITON) | TC修掉副唇 | 40 | 62 | | 9 | |
| FSF0080NB | 40*62*9 TC | | 40 | 62 | | 9 | |
| FSF0080FB | 40*62*9 TC(VITON) | | 40 | 62 | | 9 | |
| FSF0666NB | 40*62*9/13 TB9 | | 40 | 62 | | 9 | 13 |
| FSF0148NB | 40*62*10 DC | | 40 | 62 | | 10 | |
| FSF0837FB | 40*62*10 SC(VITON) | | 40 | 62 | | 10 | |
| FSF0078NB | 40*62*10 TB | | 40 | 62 | | 10 | |
| FSF0079NB | 40*62*10 TC | | 40 | 62 | | 10 | |
| FSF0079FB | 40*62*10 TC (FKM)VITON | | 40 | 62 | | 10 | |
| FSF0160NB | 40*62*10/12 HTCL | | 40 | 62 | | 10 | 12 |
| FSF0097NB | 40*62/78*10.2/15.5 TC4Y | BOSCH, UNIVERSAL | 40 | 62 | 78 | 10.2 | 15.5 |
| FSF0455NB | 40*62*11 DC(Brown) | AW2388E | 40 | 62 | | 11 | |
| FSF0841NB | 40*62*11 SC | | 40 | 62 | | 11 | |
| FSF0077NB | 40*62*11 TC | 32136-J2000 | 40 | 62 | | 11 | |
| FSF0636NB | 40*62*11 TCN | AP2388E | 40 | 62 | | 11 | |
| FSF0161NB | 40*62*11/7 HTBY Dark Blue | 003 99 77 047 | 40 | 62 | | 11 | 7 |
| FSF0331NB | 40*62*11.5 SC | | 40 | 62 | | 11.5 | |
| FSF0162NB | 40*62*11.5 TC4 | | 40 | 62 | | 11.5 | |
| FSF0905FB | 40*62*12 SC(VITON) | TC修掉附唇 | 40 | 62 | | 12 | |
| FSF0076NB | 40*62*12 TC | 90043-11066/24 | 40 | 62 | | 12 | |
| FSF0076FB | 40*62*12 TC (VITON) | (FKM) | 40 | 62 | | 12 | |
| FSF0121NB | 40*62*12 TC6 | | 40 | 62 | | 12 | |
| FSF0650NB | 40*62*12/16 SM9 | | 40 | 62 | | 12 | 16 |
| FSF0102NB | 40*62/80.5*12.5/14.5SB2Y | SB2Y | 40 | 62 | 80.5 | 12.5 | 14.5 |
| FSF0075NB | 40*62/72*13.5 TC6Y(TCU5) | AE6831E | 40 | 62 | 72 | 13.5 | |
| FSF0428NB | 40*62*14 TC | | 40 | 62 | | 14 | |
| FSF0109NB | 40.2*62*8/10 TC | | 40.2 | 62 | | 8 | 10 |
| FSF0845NB | 41*62*10 TC | | 41 | 62 | | 10 | |
| FSF0825NB | 42*62*6 SC | | 42 | 62 | | 6 | |
| FSF0642NB | 42*62*7 TC | 91252-634-005 | 42 | 62 | | 7 | |
| FSF0642FB | 42*62*7 TC(VITON) | | 42 | 62 | | 7 | |
| FSF0308NB | 42*62*7/8 TCV(NBR Blue 80) | | 42 | 62 | | 7 | 8 |
| FSF0509NB | 42*62*7/9 TC4 | (RS003) | 42 | 62 | | 7 | 9 |
| FSF0783FB | 42*62*8 SC(VITON) | | 42 | 62 | | 8 | |

| WLK CODE | OIL SEALS | DESCRIPTION | ID | OD1 | OD2 | H1 | H2 |
|-----------|-------------------------------|--------------------------|------|-----|-----|----|------|
| FSF0177NB | 42*62*8 TC | | 42 | 62 | | 8 | |
| FSF0177FB | 42*62*8 TC(VITON) | | 42 | 62 | | 8 | |
| FSF0177QB | 42*62*8 TC(VMQ) | | 42 | 62 | | 8 | |
| FSF0345NB | 42*62*9 TC | | 42 | 62 | | 9 | |
| FSF0765NB | 42*62*10 SC | | 42 | 62 | | 10 | |
| FSF0765FB | 42*62*10 SC(VITON) | | 42 | 62 | | 10 | |
| FSF0728NB | 42*62*10 TB | | 42 | 62 | | 10 | |
| FSF0123NB | 42*62*10 TC | | 42 | 62 | | 10 | |
| FSF0123NS | 42*62*10 TC(S304 SPRING) | SUS304 SPRING | 42 | 62 | | 10 | |
| FSF0720NB | 42*62*10/10.5 TCV(NBR80) | | 42 | 62 | | 10 | 10.5 |
| FSF0074NB | 42*62*11 TC | | 42 | 62 | | 11 | |
| FSF0394NB | 42*62*12 TC | | 42 | 62 | | 12 | |
| FSF0394FB | 42*62*12 TC(VITON) | | 42 | 62 | | 12 | |
| FSF0846NB | 42*62*14 TCAFY(Blue +Sponge) | 9968001 | 42 | 62 | | 14 | |
| FSF0186NB | 43*62*8 TC | | 43 | 62 | | 8 | |
| FSF0489NB | 43*62*12 TC | | 43 | 62 | | 12 | |
| FSF0342NB | 44*62*7 TC | | 44 | 62 | | 7 | |
| FSF0766NB | 44*62*8 TC | | 44 | 62 | | 8 | |
| FSF0194NB | 44*62*8/14 TBY | 09283-44008/44009 | 44 | 62 | | 8 | 14 |
| FSF0498NB | 44*62*8/14 TC9IY | | 44 | 62 | | 8 | 14 |
| FSF0073NB | 44*62*9 TC | | 44 | 62 | | 9 | |
| FSF0195N0 | 44*62/72*9 VCY | | 44 | 62 | 72 | 9 | |
| FSF0320NB | 44*62*10 HTCL(Brown) | | 44 | 62 | | 10 | |
| FSF0294NB | 44*62*10 TC | | 44 | 62 | | 10 | |
| FSF0398NB | 44*62*12 TC | | 44 | 62 | | 12 | |
| FSF0377NB | 44.5*62*10 TC | | 44.5 | 62 | | 10 | |
| FSF0193N0 | 45*62*5 VC | | 45 | 62 | | 5 | |
| FSF0620NB | 45*62*6 KB | | 45 | 62 | | 6 | |
| FSF0557NB | 45*62*6 SC | | 45 | 62 | | 6 | |
| FSF0323NB | 45*62*6 TC | | 45 | 62 | | 6 | |
| FSF0838FB | 45*62*7 SC(VITON) | | 45 | 62 | | 7 | |
| FSF0378NB | 45*62*7 TC | 91253-663-003 | 45 | 62 | | 7 | |
| FSF0664NB | 45*62*7/7.5 TCV(NBR80) Brown | | 45 | 62 | | 7 | 7.5 |
| FSF0664FB | 45*62*7/7.5 TCV(VITON) | | 45 | 62 | | 7 | 7.5 |
| FSF0204NB | 45*62*8 SB | | 45 | 62 | | 8 | |
| FSF0487FB | 45*62*8 SC(VITON) | TC副唇修掉 | 45 | 62 | | 8 | |
| FSF0072NB | 45*62*8 TC | | 45 | 62 | | 8 | |
| FSF0072FB | 45*62*8 TC(VITON) | | 45 | 62 | | 8 | |
| FSF0146NB | 45*62*9 TB | 90311-45018, 90043-10030 | 45 | 62 | | 9 | |
| FSF0205NB | 45*62*9 TBP | | 45 | 62 | | 9 | |
| FSF0071NB | 45*62*9 TC | TS60C CRANK SHAFT | 45 | 62 | | 9 | |
| FSF0071FB | 45*62*9 TC (FKM)VITON | | 45 | 62 | | 9 | |
| FSF0339NB | 45*62*9 TM | | 45 | 62 | | 9 | |
| FSF0548NB | 45*62*9/14 TC9 | | 45 | 62 | | 9 | 14 |
| FSF0851FB | 45*62*10 SC(VITON) | | 45 | 62 | | 10 | |
| FSF0940NB | 45*62*10 TA | | 45 | 62 | | 10 | |
| FSF0207NB | 45*62*10 TB | | 45 | 62 | | 10 | |
| FSF0070NB | 45*62*10 TC | | 45 | 62 | | 10 | |
| FSF0070FB | 45*62*10 TC(VITON) | | 45 | 62 | | 10 | |
| FSF0108NB | 45*62*11 DC | 90043-16005 | 45 | 62 | | 11 | |
| FSF0830NB | 45*62*11 TC | | 45 | 62 | | 11 | |
| FSF0685NB | 45*62*11/18 HTC9R | MT045A4 | 45 | 62 | | 11 | 18 |
| FSF0069NB | 45*62*12 TC | | 45 | 62 | | 12 | |
| FSF0120NB | 45*62*12 TC6 | | 45 | 62 | | 12 | |
| FSF0454NB | 45*62*12 TCN | | 45 | 62 | | 12 | |
| FSF0351NB | 45*62*12 TZ | | 45 | 62 | | 12 | |
| FSF0657NB | 46*62*7 KB | | 46 | 62 | | 7 | |

| WLK CODE | OIL SEALS | DESCRIPTION | ID | OD1 | OD2 | H1 | H2 |
|-----------|--------------------|--------------------------|----|-----|------|----|-----|
| FSF0857NB | 46*62*8 SC | | 46 | 62 | | 8 | |
| FSF0595NB | 46*62*8 TC | | 46 | 62 | | 8 | |
| FSF0711NB | 46*62*8/14 KC7Y | | 46 | 62 | | 8 | 14 |
| FSF0889NB | 46*62*9 SC | | 46 | 62 | | 9 | |
| FSF0832NB | 47*62*6 SC | | 47 | 62 | | 6 | |
| FSF0824NB | 47*62*7 TC | | 47 | 62 | | 7 | |
| FSF0414NB | 47*62*8 SC | | 47 | 62 | | 8 | |
| FSF0431NB | 47*62*8 TC | | 47 | 62 | | 8 | |
| FSF0511NB | 47*62*9 SBP | 1011-26-154 | 47 | 62 | | 9 | |
| FSF0600NB | 47*62*9 TC | | 47 | 62 | | 9 | |
| FSF0202N0 | 48*62*5 VC | | 48 | 62 | | 5 | |
| FSF0216NB | 48*62*6 TC | 40232-A0100 | 48 | 62 | | 6 | |
| FSF0826NB | 48*62*7 OKC | | 48 | 62 | | 7 | |
| FSF0217NB | 48*62*7 TA | 90311-48122, 40232-M0215 | 48 | 62 | | 7 | |
| FSF0909NB | 48*62*7 TB | | 48 | 62 | | 7 | |
| FSF0769NB | 48*62*7 TC | | 48 | 62 | | 7 | |
| FSF0769FB | 48*62*7 TC(VITON) | | 48 | 62 | | 7 | |
| FSF0067NB | 48*62*7/8.8 TA | 90311-48001 | 48 | 62 | | 7 | 8.8 |
| FSF0133NB | 48*62*7/9 TA | | 48 | 62 | | 7 | 9 |
| FSF0110NB | 48*62/70*7/10 TC5Y | 8-94224-173-0 | 48 | 62 | 70 | 7 | 10 |
| FSF0866FB | 48*62*8 SC(VITON) | | 48 | 62 | | 8 | |
| FSF0218NB | 48*62*8 TB | | 48 | 62 | | 8 | |
| FSF0068NB | 48*62*8 TC | 90311-48003 / 16 | 48 | 62 | | 8 | |
| FSF0068FB | 48*62*8 TC(VITON) | | 48 | 62 | | 8 | |
| FSF0219NB | 48*62*8/13 TC9Y | 90311-48010 | 48 | 62 | | 8 | 13 |
| FSF0220NB | 48*62*9 HTBR | 90311-48027 | 48 | 62 | | 9 | |
| FSF0635NB | 48*62*9 HTZR Brown | | 48 | 62 | | 9 | |
| FSE0394NB | 48*62*9 TB | 9958-54-8629 | 48 | 62 | | 9 | |
| FSE0742NB | 48*62*9 TB3 | | 48 | 62 | | 9 | |
| FSF0500NB | 48*62*9 TC | AE2775E | 48 | 62 | | 9 | |
| FSF0263N0 | 48*62*9/24 KC3Y | 90313-48001/05 | 48 | 62 | | 9 | 24 |
| FSF0786NB | 48*62*10 TB | | 48 | 62 | | 10 | |
| FSF0661NB | 48*62*10 TC | | 48 | 62 | | 10 | |
| FSF0661FB | 48*62*10 TC(VITON) | | 48 | 62 | | 10 | |
| FSF0637NB | 48*62/66.5*10 TB59 | 40227-21B00 | 48 | 62 | 66.5 | 10 | |
| FSF0701NB | 48*62*11 KC | | 48 | 62 | | 11 | |
| FSF0122NB | 48*62*12 TC | | 48 | 62 | | 12 | |
| FSF0896NB | 49*62*6 TC | | 49 | 62 | | 6 | |
| FSF0519NB | 49*62*8/11 TB5Y | 09283-49002, BD5150E | 49 | 62 | | 8 | 11 |
| FSF0264N0 | 50*62*4 VB | | 50 | 62 | | 4 | |
| FSF0568NB | 50*62*5 SB | | 50 | 62 | | 5 | |
| FSF0480NB | 50*62*5 SC | | 50 | 62 | | 5 | |
| FSF0918NB | 50*62*6 SC | | 50 | 62 | | 6 | |
| FSF0288NB | 50*62*7 SB | | 50 | 62 | | 7 | |
| FSF0406NB | 50*62*7 TC | 6210-28060 | 50 | 62 | | 7 | |
| FSF0406FB | 50*62*7 TC(VITON) | | 50 | 62 | | 7 | |
| FSF0652NB | 50*62*8 TC | | 50 | 62 | | 8 | |
| FSF0514NB | 50*62*9 TB | 90043-11166/249 | 50 | 62 | | 9 | |
| FSF0225NB | 50*62*9 TC | | 50 | 62 | | 9 | |
| FSF0336NB | 50*62*10 SC | | 50 | 62 | | 10 | |
| FSF0749NB | 50*62*10 TC | | 50 | 62 | | 10 | |
| FSF0624NB | 50*62*10 TZ | | 50 | 62 | | 10 | |
| FSF0447NB | 51*62*7 SB | | 51 | 62 | | 7 | |
| FSF0794NB | 52*62*7 TC | | 52 | 62 | | 7 | |
| FSF0492NB | 52*62*7/10 GA | | 52 | 62 | | 7 | 10 |
| FSF0510NB | 52*62*7/9 TC49 上牛油 | (RS007) | 52 | 62 | | 7 | 9 |
| FSF0115NB | 52*62*8 TC | | 52 | 62 | | 8 | |

| WLK CODE | OIL SEALS | DESCRIPTION | ID | OD1 | OD2 | H1 | H2 |
|-----------|----------------------------------|----------------------|-------|--------|-----|-------|-------|
| FSF0646NB | 52*62*10 TC | | 52 | 62 | | 10 | |
| FSG0278NB | 41.2*62.02*16.4 X w/sponge | D9NN703BB | 41.2 | 62.02 | | 16.4 | |
| FSF9998NB | 38.1*62.103*9.525 TA | 1.500*2.445*0.375 TA | 38.1 | 62.103 | | 9.525 | |
| FSF9845NB | 39.29*62.12/68*11/14.68H | HTBC59Y(15629) | 39.29 | 62.12 | 68 | 11 | 14.68 |
| FSF9844NB | 39.42*62.15*12.7/16.66TC | TC9(15440) | 39.42 | 62.15 | | 12.7 | 16.66 |
| FSF0439NB | 30*62.4*11/17.5 Y | 81019 | 30 | 62.4 | | 11 | 17.5 |
| FSF0365NB | 49*62.6*8/12.5 KM9 Blue Painting | | 49 | 62.6 | | 8 | 12.5 |
| FSF0484NB | 30*63*15/17 TGUY | | 30 | 63 | | 15 | 17 |
| FSF0424NB | 33*63*9 TC | | 33 | 63 | | 9 | |
| FSF0299NB | 34*63*9/15 HTC9L | 90311-34017 | 34 | 63 | | 9 | 15 |
| FSF0137NB | 34*63*9/15 TC9 | 90311-34008 | 34 | 63 | | 9 | 15 |
| FSF0309NB | 34*63*9/15.5 TC9 | | 34 | 63 | | 9 | 15.5 |
| FSF0497NB | 34*63*10 TC | | 34 | 63 | | 10 | |
| FSF0798NB | 35*63*7 SC | | 35 | 63 | | 7 | |
| FSF0560NB | 35*63*10/16.5 TB9 | 90311-35015 | 35 | 63 | | 10 | 16.5 |
| FSF0799NB | 38*63*8 TC | | 38 | 63 | | 8 | |
| FSF0734NB | 38*63*9 TC | | 38 | 63 | | 9 | |
| FSF0684NB | 38*63*9/15.5 HTC9L Brown | BH6045E | 38 | 63 | | 9 | 15.5 |
| FSF0633NB | 38*63*10/16.5 TB9 | 90311-38011 | 38 | 63 | | 10 | 16.5 |
| FSF0632NB | 38*63*10/17 TB9 | | 38 | 63 | | 10 | 17 |
| FSF0292NB | 40*63*6 SC | | 40 | 63 | | 6 | |
| FSF0713NB | 40*63*7 TC | | 40 | 63 | | 7 | |
| FSF0888NB | 40*63*10 SC | | 40 | 63 | | 10 | |
| FSF0740NB | 42*63*7 TC | | 42 | 63 | | 7 | |
| FSF0802NB | 42*63*10 TC | | 42 | 63 | | 10 | |
| FSF0188NB | 43*63*9 HTBL | | 43 | 63 | | 9 | |
| FSF0704NB | 43*63*9 HTBR | 9828-43102 | 43 | 63 | | 9 | |
| FSF0187NB | 43*63*9 TC | | 43 | 63 | | 9 | |
| FSF0682NB | 43*63*12/19 HTC9R Brown | | 43 | 63 | | 12 | 19 |
| FSF0744NB | 44*63*7 TB | | 44 | 63 | | 7 | |
| FSF0567NB | 44*63*7/10 SM9(TB) | 90043-11188 | 44 | 63 | | 7 | 10 |
| FSF0861NB | 44*63*7/10 TBY | | 44 | 63 | | 7 | 10 |
| FSF0566NB | 44*63*13 TBWY | 90043-11134 | 44 | 63 | | 13 | |
| FSF0543NB | 45*63*7 TB | | 45 | 63 | | 7 | |
| FSF0274NB | 45*63*7 TBP | 90043-11150 | 45 | 63 | | 7 | |
| FSF0558NB | 45*63*7 TC | | 45 | 63 | | 7 | |
| FSF0494NB | 45*63*7.5 HTCR | 09283-45012 | 45 | 63 | | 7.5 | |
| FSF0348NB | 45*63*10 SC | | 45 | 63 | | 10 | |
| FSF0706NB | 46*63*6.5 HTCR(BROWN) | 90311-46001 | 46 | 63 | | 6.5 | |
| FSF0221NB | 48*63*9 TC | | 48 | 63 | | 9 | |
| FSF0676NB | 48*63*11 TC | | 48 | 63 | | 11 | |
| FSF0828NB | 49*63*9/14.5 TC9Y | | 49 | 63 | | 9 | 14.5 |
| FSF0668NB | 50*63*6 KB | | 50 | 63 | | 6 | |
| FSF0750NB | 50*63*6 TC | | 50 | 63 | | 6 | |
| FSF0907NB | 50*63*8 TB | | 50 | 63 | | 8 | |
| FSF0433NB | 50*63*8 TC | | 50 | 63 | | 8 | |
| FSF0267N0 | 51*63*6 KB | B001-33-067 | 51 | 63 | | 6 | |
| FSF0767NB | 51*63*6 TB | | 51 | 63 | | 6 | |
| FSF0289NB | 51*63*7.5/10 TB9 | 04422-10020-51 | 51 | 63 | | 7.5 | 10 |
| FSF0547NB | 51*63*8 TB | | 51 | 63 | | 8 | |
| FSF0912NB | 51*63*8 TC | | 51 | 63 | | 8 | |
| FSF0576NB | 51*63*8.5 KB1(KZ) | B092-33-067 | 51 | 63 | | 8.5 | |
| FSF0291NB | 51*63*8.5/12 TZ9 | B210-33-067 | 51 | 63 | | 8.5 | 12 |
| FSF0700NB | 52*63*8 TB | | 52 | 63 | | 8 | |
| FSF0316NB | 52*63*8 TC | | 52 | 63 | | 8 | |
| FSF0481NB | 52*63*10 TC | | 52 | 63 | | 10 | |
| FSF0496N0 | 54*63*4 VB | | 54 | 63 | | 4 | |

| WLK CODE | OIL SEALS | DESCRIPTION | ID | OD1 | OD2 | H1 | H2 |
|-----------|------------------------------------|--------------------------|--------|-------|-------|-------|-------|
| FSF0643NB | 55*63*4 VG | | 55 | 63 | | 4 | |
| FSF0796NB | 55*63*5 VC | | 55 | 63 | | 5 | |
| FSF0724NB | 55*63*5 VG | | 55 | 63 | | 5 | |
| FSF0757NB | 55*63*7/10 GA | | 55 | 63 | | 7 | 10 |
| FSF9846NB | 35.53*63.09/67.87*8.14/13.08 TB59Y | Green Painting NBR Brown | 35.53 | 63.09 | 67.87 | 8.14 | 13.08 |
| FSF9988N0 | 50.8*63.09/69.85*5.59/6.45 KB5Y | 2*2.484/2.75*0.22/0.254K | 50.8 | 63.09 | 69.85 | 5.59 | 6.45 |
| FSF0936NB | 30*63.3/57*18/28 DG69Y | 228C2451P001/228C2113P00 | 30 | 63.3 | 57 | 18 | 28 |
| FSF0369NS | 35*63.3*9/12.5 TGY(S304) | 03AT38 113PH05 | 35 | 63.3 | | 9 | 12.5 |
| FSF9939NB | 31.75*63.5*8.89 TC | 1.250*2.500*0.350 TC | 31.75 | 63.5 | | 8.89 | |
| FSF9920NB | 31.75*63.5*9.53 TC | | 31.75 | 63.5 | | 9.53 | |
| FSF0900NB | 32*63.5*8.5/17.5 TG65Y | WH02X10032 | 32 | 63.5 | | 8.5 | 17.5 |
| FSF0138NB | 34.9*63.5*9.5 TC | 1.374*2.500*0.374 TC | 34.9 | 63.5 | | 9.5 | |
| FSF9866NB | 34.92*63.5*11.13 TC | | 34.92 | 63.5 | | 11.13 | |
| FSF9974NB | 34.93*63.5*9.53 TC | | 34.93 | 63.5 | | 9.53 | |
| FSF9934NB | 34.93*63.5*12.7 SA | | 34.93 | 63.5 | | 12.7 | |
| FSF9879NB | 34.93*63.5*12.7 TC | | 34.93 | 63.5 | | 12.7 | |
| FSF9878NB | 36.53*63.5*12.7 SC | | 36.53 | 63.5 | | 12.7 | |
| FSF0066NB | 38*63.5*13 SA (P1595) | | 38 | 63.5 | | 13 | |
| FSF9950NB | 38.1*63.5*6.35 TC | 1.500*2.500*0.250 TC | 38.1 | 63.5 | | 6.35 | |
| FSF9943NB | 38.1*63.5*7.95 SC | | 38.1 | 63.5 | | 7.95 | |
| FSF9943FB | 38.1*63.5*7.95 SC(VITON) | | 38.1 | 63.5 | | 7.95 | |
| FSF9932NB | 38.1*63.5*7.95 TB | | 38.1 | 63.5 | | 7.95 | |
| FSF9914NB | 38.1*63.5*7.95 TC | | 38.1 | 63.5 | | 7.95 | |
| FSF0151NB | 38.1*63.5*8 SB | 1.500*2.500*0.315 SB | 38.1 | 63.5 | | 8 | |
| FSF0152NB | 38.1*63.5*9.52 SC | 1.500*2.500*0.375 SC | 38.1 | 63.5 | | 9.52 | |
| FSF9973NB | 38.1*63.5*9.53 TC | | 38.1 | 63.5 | | 9.53 | |
| FSF0153NB | 38.1*63.5*12.7 TC | 1.500*2.500*0.500 TC | 38.1 | 63.5 | | 12.7 | |
| FSF0154NB | 38.1*63.5*13 SA | 1.500*2.500*0.512 SA | 38.1 | 63.5 | | 13 | |
| FSF9897NB | 39.7*63.5*7.95 TC | | 39.7 | 63.5 | | 7.95 | |
| FSF9897FB | 39.7*63.5*7.95 TC(VITON) | | 39.7 | 63.5 | | 7.95 | |
| FSF9824NB | 39.7*63.5*9.53 TC | | 39.7 | 63.5 | | 9.53 | |
| FSF9809NB | 39.7*63.5*12.7 SC | | 39.7 | 63.5 | | 12.7 | |
| FSF0172NB | 41.28*63.5*6.35 SB | 1.625*2.500*0.250 SB | 41.28 | 63.5 | | 6.35 | |
| FSF9968NB | 41.28*63.5*6.35 TC | | 41.28 | 63.5 | | 6.35 | |
| FSF9969NB | 41.28*63.5*9.53 TA | | 41.28 | 63.5 | | 9.53 | |
| FSF9899NB | 41.28*63.5*9.53 TB | | 41.28 | 63.5 | | 9.53 | |
| FSF9895NB | 41.28*63.5*9.53 TC | | 41.28 | 63.5 | | 9.53 | |
| FSF9887NB | 41.28*63.5*12.7 TC | | 41.28 | 63.5 | | 12.7 | |
| FSF9999NB | 42.672*63.5*9.398 TB | 1.68*2.50*0.37 TB | 42.672 | 63.5 | | 9.398 | |
| FSF9916NB | 42.86*63.5*7.9 TC | 1.680*2.500*0.310 TC | 42.86 | 63.5 | | 7.9 | |
| FSF0572NB | 42.88*63.5*9.53 TB | | 42.88 | 63.5 | | 9.53 | |
| FSF9908NB | 42.88*63.5*9.53 TC | | 42.88 | 63.5 | | 9.53 | |
| FSF9941NB | 42.88*63.50*12.70 SC | 1.688*2.500*0.500 SC | 42.88 | 63.5 | | 12.7 | |
| FSF9841NB | 44.45*63.5*6.35 TC | | 44.45 | 63.5 | | 6.35 | |
| FSF9993NB | 44.45*63.5*7.93 TB | 1.750*2.500*0.312 TB | 44.45 | 63.5 | | 7.93 | |
| FSF9976NB | 44.45*63.5*7.95 TB | | 44.45 | 63.5 | | 7.95 | |
| FSF9964NB | 44.45*63.5*7.95 TC | | 44.45 | 63.5 | | 7.95 | |
| FSF9964FB | 44.45*63.5*7.95 TC(VITON) | | 44.45 | 63.5 | | 7.95 | |
| FSF9867NB | 44.45*63.5*7.95/8.33 TCV | | 44.45 | 63.5 | | 7.95 | 8.33 |
| FSF9945NB | 44.45*63.5*9.5 TZ | | 44.45 | 63.5 | | 9.5 | |
| FSF9816NB | 44.45*63.5*9.52 SC | | 44.45 | 63.5 | | 9.52 | |
| FSF0517NB | 44.45*63.5*9.525 TC | 1.750*2.500*0.375 TC | 44.45 | 63.5 | | 9.525 | |
| FSF9994NB | 44.45*63.5*9.53 SC | 1.750*2.500*0.375 SC | 44.45 | 63.5 | | 9.53 | |
| FSF9889NB | 44.45*63.5*9.53 TB | | 44.45 | 63.5 | | 9.53 | |
| FSF9940NB | 44.45*63.5*9.53 TC | 1.750*2.500*0.375 TC | 44.45 | 63.5 | | 9.53 | |
| FSF0065NB | 44.45*63.5*12.7 TB | 1.750*2.500*0.500 TB | 44.45 | 63.5 | | 12.7 | |
| FSF0198NB | 44.45*63.5*12.7 TC | 1.750*2.500*0.500 TC | 44.45 | 63.5 | | 12.7 | |

| WLK CODE | OIL SEALS | DESCRIPTION | ID | OD1 | OD2 | H1 | H2 |
|-----------|-------------------------------------|--------------------------|-------|-------|-------|-------|-------|
| FSF9854QB | 44.96*63.5/77.39*10.85 HTB5R | HTB5R(VMQ)綠漆 | 44.96 | 63.5 | 77.39 | 10.85 | |
| FSF9893NB | 46.05*63.5*9.53 TC | | 46.05 | 63.5 | | 9.53 | |
| FSF9818NB | 47.63*63.5*6.35 SB | | 47.63 | 63.5 | | 6.35 | |
| FSF9982NB | 47.63*63.5*6.35 SC | | 47.63 | 63.5 | | 6.35 | |
| FSF9928NB | 47.63*63.5*7.95 SB | | 47.63 | 63.5 | | 7.95 | |
| FSF9961NB | 47.63*63.5*7.95 SC | | 47.63 | 63.5 | | 7.95 | |
| FSF9874NB | 47.63*63.5*9.53 TC | 1.875*2.502*2.506*0.375 | 47.63 | 63.5 | | 9.53 | |
| FSF9975NB | 49.21*63.50*9.52 SC | | 49.21 | 63.5 | | 9.52 | |
| FSF9831NB | 49.21*63.50*9.52 TC | | 49.21 | 63.5 | | 9.52 | |
| FSF9992NB | 49.21*63.50*9.53 SB | | 49.21 | 63.5 | | 9.53 | |
| FSF9855NB | 49.23*63.50*7.14 TC | | 49.23 | 63.5 | | 7.14 | |
| FSF9811NB | 49.23*63.5*9.53 SB | | 49.23 | 63.5 | | 9.53 | |
| FSF9989N0 | 49.28*63.5/68.66*6.35/7.14 KB5 | 1.94*2.5/2.703*0.25/0.28 | 49.28 | 63.5 | 68.66 | 6.35 | 7.14 |
| FSF9829NB | 50.39*63.5*8.5 HTCL | | 50.39 | 63.5 | | 8.5 | |
| FSF9909NB | 50.8*63.5*6.35 TB | | 50.8 | 63.5 | | 6.35 | |
| FSF9937NB | 50.8*63.5*6.35 TC | | 50.8 | 63.5 | | 6.35 | |
| FSF9911NB | 50.8*63.5*9.53 TB | 2.000*2.500*0.375 | 50.8 | 63.5 | | 9.53 | |
| FSF9955NB | 50.8*63.5*9.53 TC | 2.000*2.500*0.375 | 50.8 | 63.5 | | 9.53 | |
| FSF0036NB | 38.1*63.55*11.10 SBP Red Painting | 1.500*2.502*0.437 SBP | 38.1 | 63.55 | | 11.1 | |
| FSF9995NB | 39.37*63.55*12.7 TB2 | JEEP G/B | 39.37 | 63.55 | | 12.7 | |
| FSF0171NB | 41.28*63.55*7.92 TB2 | 1.625*2.502*0.312 TB2 | 41.28 | 63.55 | | 7.92 | |
| FSF9942NB | 41.28*63.55*7.95 TB | | 41.28 | 63.55 | | 7.95 | |
| FSF9942FB | 41.28*63.55*7.95 TB(FKM) | VITON | 41.28 | 63.55 | | 7.95 | |
| FSE9902NB | 42.88*63.55/73.03*9.98/21.21 HTB59L | Blue Painting | 42.88 | 63.55 | 73.03 | 9.98 | 21.21 |
| FSF0269N0 | 46.84*63.55*6.35 VBY Green Painting | 1.844*2.502*0.250 VBY | 46.84 | 63.55 | | 6.35 | |
| FSF0174NB | 36.67*63.63*13 SA | 1.444*2.505*0.512 SA | 36.67 | 63.63 | | 13 | |
| FSF0420NB | 44.5*63.63*9.5 TC | 1.752*2.505*0.374 TC | 44.5 | 63.63 | | 9.5 | |
| FSF0272NB | 38*63.65*9.5 SC | 1.496*2.506*0.374 SC | 38 | 63.65 | | 9.5 | |
| FSF0901NB | 30*64*15/23 TG56Y | | 30 | 64 | | 15 | 23 |
| FSF0475NB | 35*64*8 SC | | 35 | 64 | | 8 | |
| FSF0451NB | 35*64*9 TC | | 35 | 64 | | 9 | |
| FSF0722NB | 35*64*10 TC | | 35 | 64 | | 10 | |
| FSF0459NB | 35*64*12 TC | | 35 | 64 | | 12 | |
| FSF0461NB | 35*64*13 HTC3R | | 35 | 64 | | 13 | |
| FSF0526NB | 35*64*13 TB | | 35 | 64 | | 13 | |
| FSF0142NB | 35*64*13 TC | | 35 | 64 | | 13 | |
| FSF0176NB | 35*64*13 TC3 | 38189-02700/A6100 | 35 | 64 | | 13 | |
| FSF0812NB | 36*64*11/19 Y | | 36 | 64 | | 11 | 19 |
| FSF0723NB | 38*64*10 TC | | 38 | 64 | | 10 | |
| FSF0919NB | 40*64*7 TB | | 40 | 64 | | 7 | |
| FSF0619NB | 40*64*8/14.5 HTC9R BROWN | 90311-40025 | 40 | 64 | | 8 | 14.5 |
| FSF0737NB | 40*64*10 TC | | 40 | 64 | | 10 | |
| FSF0571NB | 40*64*11/16 TB59 | 是40*64*16 TB59(TBY) | 40 | 64 | | 11 | 16 |
| FSF0549NB | 40*64*12 TB5Y | 0223-27-018 | 40 | 64 | | 12 | |
| FSF0124NB | 40*64*12 TC | | 40 | 64 | | 12 | |
| FSF0667NB | 40*64*12/17.5 TB9 | M005-27-165 | 40 | 64 | | 12 | 17.5 |
| FSF0276NB | 40*64*16 TB59(TBY) | 90043-11106 | 40 | 64 | | 16 | |
| FSF0739NB | 41*64*10 TC | | 41 | 64 | | 10 | |
| FSF0627NB | 42*64*6 KC | | 42 | 64 | | 6 | |
| FSF0332NB | 42*64*7 TC | | 42 | 64 | | 7 | |
| FSF0317NB | 42*64*8 TC | | 42 | 64 | | 8 | |
| FSF0710NB | 42*64*11.2/8 SGYL | | 42 | 64 | | 11.2 | 8 |
| FSF0534NB | 42*64*12 TC | | 42 | 64 | | 12 | |
| FSF0915NB | 44*64*8 TB | | 44 | 64 | | 8 | |
| FSF0745NB | 44*64*9 TC | | 44 | 64 | | 9 | |
| FSF0367NB | 44*64*12 TC | | 44 | 64 | | 12 | |
| FSF0477NB | 45*64*7 TC | | 45 | 64 | | 7 | |

| WLK CODE | OIL SEALS | DESCRIPTION | ID | OD1 | OD2 | H1 | H2 |
|-----------|-------------------------|-----------------|------|-----|------|------|------|
| FSF0490NB | 45*64*8 TC | | 45 | 64 | | 8 | |
| FSF0327NB | 45*64*9 TC | | 45 | 64 | | 9 | |
| FSF0709NB | 45*64/70*9/14 KCY | | 45 | 64 | 70 | 9 | 14 |
| FSF0768NB | 45*64*10 TC | | 45 | 64 | | 10 | |
| FSF0208NB | 45*64*12 HTA2 | 011 997 51 47A | 45 | 64 | | 12 | |
| FSF0401NB | 45*64*12 TC | | 45 | 64 | | 12 | |
| FSF0890NB | 46*64*8 SC | | 46 | 64 | | 8 | |
| FSF0430NB | 46*64*8 TC | | 46 | 64 | | 8 | |
| FSF0891NB | 46*64*9 TC | | 46 | 64 | | 9 | |
| FSF0803NB | 46*64*10 TC | | 46 | 64 | | 10 | |
| FSF0719NB | 47*64/68*6/14 KES-S | 91250-SB0-623 | 47 | 64 | 68 | 6 | 14 |
| FSF0787NB | 47*64*7 Y | | 47 | 64 | | 7 | |
| FSF0580NB | 48*64*10 TC | | 48 | 64 | | 10 | |
| FSF0580FB | 48*64*10 TC(VITON) | | 48 | 64 | | 10 | |
| FSF0852NB | 48*64*12 TC | | 48 | 64 | | 12 | |
| FSF0442NB | 48*64*12/7.4 HTBW(Blue) | | 48 | 64 | | 12 | 7.4 |
| FSF0662NB | 48*64*14 TA | | 48 | 64 | | 14 | |
| FSF0618NB | 48*64*14 TB | | 48 | 64 | | 14 | |
| FSF0628NB | 50*64*6.5 TC3 | 8-94108-663-0 | 50 | 64 | | 6.5 | |
| FSF0729NB | 50*64*7 TC | | 50 | 64 | | 7 | |
| FSF0820NB | 50*64*8 TC | | 50 | 64 | | 8 | |
| FSF0937NB | 50*64*10 SC | | 50 | 64 | | 10 | |
| FSF0434NB | 50*64*10 TC | | 50 | 64 | | 10 | |
| FSF0834NB | 50*64*10/13 Y | | 50 | 64 | | 10 | 13 |
| FSF0436NB | 52*64*9 TB | 9828-52116/5 | 52 | 64 | | 9 | |
| FSF0683NB | 52*64*10 TC | | 52 | 64 | | 10 | |
| FSF0754NB | 54*64*9 TC | | 54 | 64 | | 9 | |
| FSF0550N0 | 54*64*9/24 KCY | 90313-54001 | 54 | 64 | | 9 | 24 |
| FSF0775NB | 30*65*8 TC | | 30 | 65 | | 8 | |
| FSF0784NB | 30*65*10 SC | | 30 | 65 | | 10 | |
| FSF0064NB | 30*65*10 TC | G40/42 | 30 | 65 | | 10 | |
| FSF0063NB | 31*65/80*15 AC | AC8176P YZC | 31 | 65 | 80 | 15 | |
| FSF0645NB | 32*65*6.5 TC | | 32 | 65 | | 6.5 | |
| FSF0774NB | 32*65*9 TC | | 32 | 65 | | 9 | |
| FSF0382NB | 32*65*10 TC | | 32 | 65 | | 10 | |
| FSF0565NB | 32*65*12 TB2Y | BD1355F | 32 | 65 | | 12 | |
| FSF0353NB | 32*65*12 TC | | 32 | 65 | | 12 | |
| FSF0466NB | 32*65*13 TC | | 32 | 65 | | 13 | |
| FSF0694NB | 34.7*65*12 TB2Y | BD3298F | 34.7 | 65 | | 12 | |
| FSF0935NB | 35*65*7 TC | | 35 | 65 | | 7 | |
| FSF0656NB | 35*65/73.5*7.5/13 TG5 | 122447 | 35 | 65 | 73.5 | 7.5 | 13 |
| FSF0322NB | 35*65*8 TC | | 35 | 65 | | 8 | |
| FSF0894NB | 35*65*9 SC | | 35 | 65 | | 9 | |
| FSF0363NB | 35*65*10 SB | | 35 | 65 | | 10 | |
| FSF0607NB | 35*65*10 SC | 03AT51 | 35 | 65 | | 10 | |
| FSF0384NB | 35*65*10 TC | 03AT68 | 35 | 65 | | 10 | |
| FSF0384FB | 35*65*10 TC(VITON) | | 35 | 65 | | 10 | |
| FSF0273N0 | 35*65/74*10/14.5 TC45Y | | 35 | 65 | 74 | 10 | 14.5 |
| FSC0489NB | 35*65*11 TC | | 35 | 65 | | 11 | |
| FSF0143NB | 35*65*11/15 TC4 | 03AT21, 113GR02 | 35 | 65 | | 11 | 15 |
| FSF0553NB | 35*65*12 TB(TZ) | | 35 | 65 | | 12 | |
| FSF0411NB | 35*65*12 TC | | 35 | 65 | | 12 | |
| FSF0470NB | 35*65*13 TB | | 35 | 65 | | 13 | |
| FSF0111NB | 35*65*13 TB3 | 5-09625-002-1 | 35 | 65 | | 13 | |
| FSF0616NB | 35*65*14.5/18 TC9Y | | 35 | 65 | | 14.5 | 18 |
| FSF0467NB | 36*65*12 SC | | 36 | 65 | | 12 | |
| FSF0735NB | 38*65*8 TC | | 38 | 65 | | 8 | |

| WLK CODE | OIL SEALS | DESCRIPTION | ID | OD1 | OD2 | H1 | H2 |
|-----------|-------------------------------|--------------------------|-------|-----|-----|-----|----|
| FSF0149NB | 38*65*9 TB(TM) | 90311-38007 | 38 | 65 | | 9 | |
| FSF0150NB | 38*65*9 TC | | 38 | 65 | | 9 | |
| FSF0931NB | 38*65*10 TB | | 38 | 65 | | 10 | |
| FSF0388NB | 38*65*10 TC | | 38 | 65 | | 10 | |
| FSF0388FB | 38*65*10 TC(VITON) | | 38 | 65 | | 10 | |
| FSF0282NB | 38*65*12/19 TB9 | 90311-38124/38014 | 38 | 65 | | 12 | 19 |
| FSF0800NB | 39*65*9/15 HTC69LY | | 39 | 65 | | 9 | 15 |
| FSF0185N0 | 40*65*5 VC | | 40 | 65 | | 5 | |
| FSF0639NB | 40*65*7 TC | | 40 | 65 | | 7 | |
| FSF0163FB | 40*65*8 TC(VITON) | | 40 | 65 | | 8 | |
| FSF0163NB | 40*65*8 TC(實際TC6) | 是QLN 35*65*8/14.5外套 | 40 | 65 | | 8 | |
| FSF0062NB | 40*65*9 TC | | 40 | 65 | | 9 | |
| FSF0062FB | 40*65*9 TC(VITON) | | 40 | 65 | | 9 | |
| FSF0061NB | 40*65*10 SC | | 40 | 65 | | 10 | |
| FSF0943NB | 40*65*10 TB | | 40 | 65 | | 10 | |
| FSF0164NB | 40*65*10 TC | | 40 | 65 | | 10 | |
| FSF0164NS | 40*65*10 TC(S304 SPRING) | | 40 | 65 | | 10 | |
| FSF0586NB | 40*65*12 TC | | 40 | 65 | | 12 | |
| FSF0586FB | 40*65*12 TC(VITON) | | 40 | 65 | | 12 | |
| FSF0318NB | 40*65*13 TC | | 40 | 65 | | 13 | |
| FSF0158NB | 40*65*14 TC | | 40 | 65 | | 14 | |
| FSF0715NB | 42*65*7 TC | | 42 | 65 | | 7 | |
| FSF0328NB | 42*65*8 SC | | 42 | 65 | | 8 | |
| FSF0429NB | 42*65*8 TC | | 42 | 65 | | 8 | |
| FSF0524NB | 42*65*9 TB | | 42 | 65 | | 9 | |
| FSF0060NB | 42*65*9 TC | MB-092145, 0604-26-184 | 42 | 65 | | 9 | |
| FSF0178NB | 42*65*10 SC | | 42 | 65 | | 10 | |
| FSF0395NB | 42*65*10 TC | | 42 | 65 | | 10 | |
| FSF0395FB | 42*65*10 TC(VITON) | | 42 | 65 | | 10 | |
| FSF0504NB | 42*65*11 TC | | 42 | 65 | | 11 | |
| FSF0493NB | 42*65*12 DC(BROWN) | | 42 | 65 | | 12 | |
| FSF0059NB | 42*65*12 HSBR | | 42 | 65 | | 12 | |
| FSF0116NB | 42*65*12 HSC | | 42 | 65 | | 12 | |
| FSF0181NB | 42*65*12 HTBR | MB-092145 | 42 | 65 | | 12 | |
| FSF0660NB | 42*65*12 SA | | 42 | 65 | | 12 | |
| FSF0180NB | 42*65*12 SB | | 42 | 65 | | 12 | |
| FSF0113NB | 42*65*12 TA2 | | 42 | 65 | | 12 | |
| FSF0179NB | 42*65*12 TB | MB-160578 | 42 | 65 | | 12 | |
| FSF0058NB | 42*65*12 TC | MB-092145, 90311-42083 | 42 | 65 | | 12 | |
| FSF0456NB | 42*65*12 TCN(NBR80-85 Shore) | | 42 | 65 | | 12 | |
| FSF0833NB | 43*65*8 SC | | 43 | 65 | | 8 | |
| FSF0354NB | 43*65*8 TC | | 43 | 65 | | 8 | |
| FSF0468NB | 43*65*10 TC | | 43 | 65 | | 10 | |
| FSF0057NB | 44*65*6.5/9 SC6Y | NM85/110 曲軸 GJ7422P | 44 | 65 | | 6.5 | 9 |
| FSF0679NB | 44*65*8 TC | | 44 | 65 | | 8 | |
| FSF0056NB | 44*65*10 TC | NM85/110 曲軸 | 44 | 65 | | 10 | |
| FSF0535NB | 44*65*11 HTCR | K411140-0 | 44 | 65 | | 11 | |
| FSF0472NB | 44*65*11 TC | | 44 | 65 | | 11 | |
| FSF0853NB | 44.45*65*10 TB2 | | 44.45 | 65 | | 10 | |
| FSF0542NB | 45*65*5 TB | 3900-33-065. 0603-33-065 | 45 | 65 | | 5 | |
| FSF0482NB | 45*65*5 TC | | 45 | 65 | | 5 | |
| FSF0215N0 | 45*65*5 VC | | 45 | 65 | | 5 | |
| FSF0922NB | 45*65*6 TCV | | 45 | 65 | | 6 | |
| FSF0326NB | 45*65*7 TC | | 45 | 65 | | 7 | |
| FSF0923NB | 45*65*7 TCHP | | 45 | 65 | | 7 | |
| FSF0422NB | 45*65*8 SC | | 45 | 65 | | 8 | |
| FSF0422FB | 45*65*8 SC(VITON) | | 45 | 65 | | 8 | |

| WLK CODE | OIL SEALS | DESCRIPTION | ID | OD1 | OD2 | H1 | H2 |
|-----------|-------------------------|--------------------------|------|-----|-----|------|----|
| FSF0402NB | 45*65*8 TC | | 45 | 65 | | 8 | |
| FSF0402FB | 45*65*8 TC (FKM)VITON | | 45 | 65 | | 8 | |
| FSF0402NS | 45*65*8 TC(S304 SPRING) | | 45 | 65 | | 8 | |
| FSF0209NB | 45*65*9 TC | | 45 | 65 | | 9 | |
| FSF0055NB | 45*65*10 SB | | 45 | 65 | | 10 | |
| FSF0054NB | 45*65*10 SC | | 45 | 65 | | 10 | |
| FSF0054FB | 45*65*10 SC(VITON) | TC修掉副唇 | 45 | 65 | | 10 | |
| FSF0443NB | 45*65*10 TA | | 45 | 65 | | 10 | |
| FSF0791NB | 45*65*10 TB | | 45 | 65 | | 10 | |
| FSF0117NB | 45*65*10 TC | AE2658F, 113LG89 | 45 | 65 | | 10 | |
| FSF0117FB | 45*65*10 TC(FKM)VITON | | 45 | 65 | | 10 | |
| FSF0117QB | 45*65*10 TC(VMQ) | | 45 | 65 | | 10 | |
| FSF0792NB | 45*65*12 TB | | 45 | 65 | | 12 | |
| FSF0053NB | 45*65*12 TC | 90311-45069 | 45 | 65 | | 12 | |
| FSF0290NB | 45*65*12 TCN | AP2659E | 45 | 65 | | 12 | |
| FSF0052NB | 46*65*9 TC | | 46 | 65 | | 9 | |
| FSF0817NB | 46*65*10 TA | | 46 | 65 | | 10 | |
| FSF0448NB | 46*65*10 TC | | 46 | 65 | | 10 | |
| FSF0596NB | 47*65*8 TC | | 47 | 65 | | 8 | |
| FSF0343NB | 47*65*10 SC | | 47 | 65 | | 10 | |
| FSF0555NB | 47*65*10 TC | | 47 | 65 | | 10 | |
| FSF0702NB | 48*65*7 KC3 | | 48 | 65 | | 7 | |
| FSF0747NB | 48*65*7 TC | | 48 | 65 | | 7 | |
| FSF0747FB | 48*65*7 TC(VITON) | | 48 | 65 | | 7 | |
| FSF0653NB | 48*65*8 TC | | 48 | 65 | | 8 | |
| FSF0850NB | 48*65*9 HTCR | | 48 | 65 | | 9 | |
| FSF0453NB | 48*65*9 HTMR | 32219-90014 | 48 | 65 | | 9 | |
| FSF0523NB | 48*65*9 SEB | | 48 | 65 | | 9 | |
| FSF0182NB | 48*65*9 TB(TM) | 9958-54-8659,32219-90014 | 48 | 65 | | 9 | |
| FSF0127NB | 48*65*9 TC | MH-034052, MH-034071/177 | 48 | 65 | | 9 | |
| FSF0049NB | 48*65*9.5 HSC | | 48 | 65 | | 9.5 | |
| FSF0222NB | 48*65*10 TB | | 48 | 65 | | 10 | |
| FSF0405NB | 48*65*10 TC | 40227-73000 | 48 | 65 | | 10 | |
| FSF0405FB | 48*65*10 TC(VITON) | | 48 | 65 | | 10 | |
| FSF0933NB | 48*65*10.3 TBCN(NBR85) | BP4339E | 48 | 65 | | 10.3 | |
| FSF0333NB | 48*65*12 TB | | 48 | 65 | | 12 | |
| FSF0808NB | 48*65*12 TC | | 48 | 65 | | 12 | |
| FSF0673NB | 49*65*6 TC | | 49 | 65 | | 6 | |
| FSF0488NB | 49*65*10 SC | | 49 | 65 | | 10 | |
| FSF0648NB | 50*65*6 TC | | 50 | 65 | | 6 | |
| FSF0929FB | 50*65*7 TC(VITON) | | 50 | 65 | | 7 | |
| FSF0491NB | 50*65*7/10 WPR | | 50 | 65 | | 7 | 10 |
| FSF0048NB | 50*65*7.5 TC | | 50 | 65 | | 7.5 | |
| FSF0844NB | 50*65*8 HTCR | | 50 | 65 | | 8 | |
| FSF0817FB | 50*65*8 SC(VITON) | | 50 | 65 | | 8 | |
| FSF0047NB | 50*65*8 TC | 13042-05E01 | 50 | 65 | | 8 | |
| FSF0047FB | 50*65*8 TC(VITON) | | 50 | 65 | | 8 | |
| FSF0226NB | 50*65*9 TB(TM) | MT-141132 | 50 | 65 | | 9 | |
| FSF0423NB | 50*65*9 TC | | 50 | 65 | | 9 | |
| FSF0046NB | 50*65/75*9/5 VCY | | 50 | 65 | 75 | 9 | 5 |
| FSF0227NB | 50*65*10 DGS(HTG4W)ACM | 6點白漆壓克力 | 50 | 65 | | 10 | |
| FSF0927FB | 50*65*10 SC(VITON) | | 50 | 65 | | 10 | |
| FSF0400NB | 50*65*10 TB | MB-092437 | 50 | 65 | | 10 | |
| FSF0045NB | 50*65*10 TC | | 50 | 65 | | 10 | |
| FSF0045FB | 50*65*10 TC(VITON) | VITON | 50 | 65 | | 10 | |
| FSF0770NB | 50*65*10/14 TC9 | | 50 | 65 | | 10 | 14 |
| FSF0829NB | 50.8*65*9/7 TCV | | 50.8 | 65 | | 9 | 7 |

| WLK CODE | OIL SEALS | DESCRIPTION | ID | OD1 | OD2 | H1 | H2 |
|------------|-------------------------------------|-------------------------|-------|--------|-----|-------|------|
| FSF0044NB | 50.8*65*9/9.5 TCY | | 50.8 | 65 | | 9 | 9.5 |
| FSF0691NB | 51*65*7 TB | | 51 | 65 | | 7 | |
| FSF0582NB | 51*65*7 TC | | 51 | 65 | | 7 | |
| FSF0582FB | 51*65*7 TC(VITON) | R590014V | 51 | 65 | | 7 | |
| FSF0298NB | 51*65*9 TB | MA-181498 | 51 | 65 | | 9 | |
| FSF0672NB | 52*65*7.5/12 TB9 | 90311-52010 | 52 | 65 | | 7.5 | 12 |
| FSF0795NB | 52*65*8 SC | | 52 | 65 | | 8 | |
| FSF0680NB | 52*65*8 TC | | 52 | 65 | | 8 | |
| FSF0324NB | 52*65*9 SB2Y | 實際TB2型式 | 52 | 65 | | 9 | |
| FSF0240NB | 52*65*9 TB | 90311-52059, MA181498 | 52 | 65 | | 9 | |
| FSF0527NB | 52*65*9 TC | | 52 | 65 | | 9 | |
| FSF0529NB | 52*65*10 TC | | 52 | 65 | | 10 | |
| FSF0858NB | 52*65*12 TC | | 52 | 65 | | 12 | |
| FSF0437NB | 54*65*8 TC | | 54 | 65 | | 8 | |
| FSF0755NB | 54*65*10 TC | | 54 | 65 | | 10 | |
| FSF0043NB | 54*65*13 TB(TM) | 40232-B9500 | 54 | 65 | | 13 | |
| FSF0042NB | 54*65*13 TC | | 54 | 65 | | 13 | |
| FSF0788NB | 55*65*5 TC | | 55 | 65 | | 5 | |
| FSF0788FB | 55*65*5 TC(VITON) | | 55 | 65 | | 5 | |
| FSF0758NB | 55*65*7/10 GA | | 55 | 65 | | 7 | 10 |
| FSF0421NB | 55*65*8 TC | | 55 | 65 | | 8 | |
| FSF0505NB | 55*65*9 TC | | 55 | 65 | | 9 | |
| FSF0505FB | 55*65*9 TC (FKM)VITON | | 55 | 65 | | 9 | |
| FSF0930FB | 55*65*10 TC(VITON) | | 55 | 65 | | 10 | |
| FSF0597NB | 56*65*12 TC | | 56 | 65 | | 12 | |
| FSF0114NB | 43.69*65.07*12.7 KBI | 1.720*2.562*0.500 KBI | 43.69 | 65.07 | | 12.7 | |
| FSF9881N0 | 50.8*65.07*5.94 VBP Green Painting | | 50.8 | 65.07 | | 5.94 | |
| FSF9987N0 | 50.8*65.075*5.588 KBJ | 2.000*2.562*0.220 KBJ | 50.8 | 65.075 | | 5.588 | |
| FSF0816NB | 44.45*65.09*7.95 TB | | 44.45 | 65.09 | | 7.95 | |
| FSF9817NB | 38.1*65.1*12.7 SC | | 38.1 | 65.1 | | 12.7 | |
| FSF9856NB | 44.45*65.10*7.95 TBP Green Painting | 1017 | 44.45 | 65.1 | | 7.95 | |
| FSF9986N0 | 50.8*65.1*5.59 KBJ | 是 50.8*65.075*5.588 KBJ | 50.8 | 65.1 | | 5.59 | |
| FSF0041NB | 42*65.12*12 HTB | | 42 | 65.12 | | 12 | |
| FSF0372NB | 50*65.2*9.7/14 HTB9Painting OD | 02442-BAGE (Paint) | 50 | 65.2 | | 9.7 | 14 |
| FSF0669NB | 50*65.3*8 TC4 | 28015-AA015 | 50 | 65.3 | | 8 | |
| FSF0040NB | 41*65.5*12.5 TB | | 41 | 65.5 | | 12.5 | |
| FSF0731NB | 30*66*12 TC | | 30 | 66 | | 12 | |
| FSF0887NB | 32*66*10 SC | | 32 | 66 | | 10 | |
| FSF05373NB | 33*66*13 HSCW | | 33 | 66 | | 13 | |
| FSF0764NB | 35*66*10 TG | | 35 | 66 | | 10 | |
| FSF0626NB | 37*66*9.5 SC | | 37 | 66 | | 9.5 | |
| FSF0329NB | 37*66*9.5/12 TGU9Y | LG 4036ER2003A | 37 | 66 | | 9.5 | 12 |
| FSF0485NB | 37*66*9.5/14 TGU9Y | | 37 | 66 | | 9.5 | 14 |
| FSF0897NB | 40*66*7 TC | | 40 | 66 | | 7 | |
| FSF0356NB | 40*66*8/11.5 HTC9R | BH0253E | 40 | 66 | | 8 | 11.5 |
| FSF0738NB | 40*66*10 TC | | 40 | 66 | | 10 | |
| FSF0854NB | 40*66*10/11.5 TG69Y | HAIER 0020300440 | 40 | 66 | | 10 | 11.5 |
| FSF0478NB | 40*66*11 TC | | 40 | 66 | | 11 | |
| FSF0839NB | 42*66*6 HTGR | | 42 | 66 | | 6 | |
| FSF0771NB | 42*66*7 TB | | 42 | 66 | | 7 | |
| FSF0644NB | 42*66*8 TC | | 42 | 66 | | 8 | |
| FSF0644FB | 42*66*8 TC(VITON) | | 42 | 66 | | 8 | |
| FSF0183NB | 42*66*10 TC | 33140-33G02 | 42 | 66 | | 10 | |
| FSF0809QB | 42*66*11.5/18.5 VCK59Y(VMQ) w/Felt | ME-240328 4M40 Crank | 42 | 66 | | 11.5 | 18.5 |
| FSF0579NB | 43*66*10 TC | | 43 | 66 | | 10 | |
| FSF0926NB | 45*66*6 SC | | 45 | 66 | | 6 | |
| FSF0362NB | 45*66*10 TC | | 45 | 66 | | 10 | |

| WLK CODE | OIL SEALS | DESCRIPTION | ID | OD1 | OD2 | H1 | H2 |
|-----------|-------------------------------|--------------------------|-------|-------|-------|-------|-------|
| FSF0212NB | 47*66*6 TBY | 1329820 | 47 | 66 | | 6 | |
| FSF0690NB | 48*66*10 SB | | 48 | 66 | | 10 | |
| FSF0173NB | 48*66*12 TC | | 48 | 66 | | 12 | |
| FSF0038NB | 48*66*13 TBY | NT70/PMY4/F5 曲軸 | 48 | 66 | | 13 | |
| FSF0229NB | 50*66*6 TC | 商標PTI | 50 | 66 | | 6 | |
| FSF0942FB | 50*66*8 HTCR(VITON) | | 50 | 66 | | 8 | |
| FSF0751NB | 50*66*8 SC | | 50 | 66 | | 8 | |
| FSF0725NB | 50*66/75*9.3/14 TBCJAY | K7 | 50 | 66 | 75 | 9.3 | 14 |
| FSF0469NB | 50*66*10 SC | | 50 | 66 | | 10 | |
| FSF0037NB | 51*66*7 (9K120)軟 | 聖育專用 | 51 | 66 | | 7 | |
| FSF0752NB | 51*66*7.5/10.5 TB9 | | 51 | 66 | | 7.5 | 10.5 |
| FSF0515NB | 51.9*66*8/10 TB9 | MB-808444無研磨 | 51.9 | 66 | | 8 | 10 |
| FSF0647NB | 52*66*7 SC | | 52 | 66 | | 7 | |
| FSF0281NB | 52*66*7.5/12 TB9Y | 04422-12020, 90311-52006 | 52 | 66 | | 7.5 | 12 |
| FSF0866NB | 52*66*8 TC | | 52 | 66 | | 8 | |
| FSF0314NB | 52*66*8/10.5 TB9 | | 52 | 66 | | 8 | 10.5 |
| FSF0344NB | 54*66*7 TC | | 54 | 66 | | 7 | |
| FSF0521NB | 54*66*7.5/10 TB9Y(TM9) | 90311-54003 | 54 | 66 | | 7.5 | 10 |
| FSF0230NB | 50*66.5*13/15.5 TCY(TC9) | F4094, MB-109057 | 50 | 66.5 | | 13 | 15.5 |
| FSF0191NB | 43.4*66.6*12 SC | 1.708*2.622*0.472 SC | 43.4 | 66.6 | | 12 | |
| FSF9991N0 | 49.28*66.60*6.35/13.49 KB9 | 1.94*2.622*0.25/0.531KB9 | 49.28 | 66.6 | | 6.35 | 13.49 |
| FSF9947NB | 42.06*66.62*9.7 HTCR | | 42.06 | 66.62 | | 9.7 | |
| FSF9848NB | 42.88*66.62/80.16*13.46 HTB5R | Blue Painting 16805 | 42.88 | 66.62 | 80.16 | 13.46 | |
| FSF9847NB | 44.37*66.62/72.82*9.27 HSB5R | Green Painting 17458 | 44.37 | 66.62 | 72.82 | 9.27 | |
| FSF9833NB | 46.05*66.62*7.95 SB | | 46.05 | 66.62 | | 7.95 | |
| FSF9864NB | 50.8*66.62*7.95 TB | | 50.8 | 66.62 | | 7.95 | |
| FSF9990N0 | 50.8*66.62/76.99*16.13 Y | 2*2.623/3.031*0.635 Y紅 | 50.8 | 66.62 | 76.99 | 16.13 | |
| FSF9839NB | 44.45*66.67*9.52 TC | | 44.45 | 66.67 | | 9.52 | |
| FSF0035NB | 47.62*66.67*9.52 SC | 1.875*2.625*0.375 SC | 47.62 | 66.67 | | 9.52 | |
| FSF9923NB | 34.92*66.68*9.53 SC | | 34.92 | 66.68 | | 9.53 | |
| FSF9919NB | 38.1*66.68*9.53 TC | | 38.1 | 66.68 | | 9.53 | |
| FSF9967NB | 41.28*66.68*7.95 TB | | 41.28 | 66.68 | | 7.95 | |
| FSF9981NB | 41.28*66.68*9.53 TC | 1.625*2.625*0.375 TC | 41.28 | 66.68 | | 9.53 | |
| FSF9843NB | 42.88*66.68*9.53 TB | | 42.88 | 66.68 | | 9.53 | |
| FSF9823NB | 44.45*66.68*7.95 TC | | 44.45 | 66.68 | | 7.95 | |
| FSF9963NB | 44.45*66.68*9.53 TB | | 44.45 | 66.68 | | 9.53 | |
| FSF9894NB | 44.45*66.68*12.7 TC | | 44.45 | 66.68 | | 12.7 | |
| FSF9918NB | 47.63*66.68*7.95 SB | | 47.63 | 66.68 | | 7.95 | |
| FSF9960NB | 47.63*66.68*7.95 SC | | 47.63 | 66.68 | | 7.95 | |
| FSF9927NB | 47.63*66.68*7.95 TB | | 47.63 | 66.68 | | 7.95 | |
| FSF9860NB | 47.63*66.68*9.53 TB | | 47.63 | 66.68 | | 9.53 | |
| FSF9862NB | 47.63*66.68*11.51 TC | | 47.63 | 66.68 | | 11.51 | |
| FSF9826FB | 49.23*66.68*6.35 TC(FKM) | | 49.23 | 66.68 | | 6.35 | |
| FSF9924NB | 49.23*66.68*7.95 TB | | 49.23 | 66.68 | | 7.95 | |
| FSF9880N0 | 50.8*66.68*6.35 VB | | 50.8 | 66.68 | | 6.35 | |
| FSF9954NB | 50.8*66.68*9.53 TB | | 50.8 | 66.68 | | 9.53 | |
| FSF9996FB | 50.8*66.8*9.53 TB(FKM) | | 50.8 | 66.8 | | 9.53 | |
| FSF0213QB | 47*66.9*11 HSC (VMQ) | | 47 | 66.9 | | 11 | |
| FSF9851NB | 35*67*12/18 HTC9R | 13978 | 35 | 67 | | 12 | 18 |
| FSF0599NB | 35*67*12/18 TC9 | 38189-U3000 | 35 | 67 | | 12 | 18 |
| FSF0934NB | 35*67*12/20 HTC9L | | 35 | 67 | | 12 | 20 |
| FSF0932NB | 40*67*7 TC | | 40 | 67 | | 7 | |
| FSF0815NB | 40*67*8 TC | | 40 | 67 | | 8 | |
| FSF0906NB | 40*67*10 SA | | 40 | 67 | | 10 | |
| FSF0452NB | 40*67*10 TC | | 40 | 67 | | 10 | |
| FSF0686NB | 40*67*12 TC | | 40 | 67 | | 12 | |
| FSF0541NB | 42*67*10 TC | | 42 | 67 | | 10 | |

| WLK CODE | OIL SEALS | DESCRIPTION | ID | OD1 | OD2 | H1 | H2 |
|-----------|--|--------------------|-------|-------|-------|-------|------|
| FSF0695NB | 42*67*12 TC | | 42 | 67 | | 12 | |
| FSF0196NB | 44*67*10 HTC | 33 13 1 214 100A | 44 | 67 | | 10 | |
| FSF0196AB | 44*67*10 HTC(ACM) | 33 13 1 214 100A | 44 | 67 | | 10 | |
| FSF0473NB | 44*67*10 TC | | 44 | 67 | | 10 | |
| FSF0293NB | 45*67*7 TB | | 45 | 67 | | 7 | |
| FSF0364NB | 45*67*8 HTGR(NBR) | 010 997 3347 | 45 | 67 | | 8 | |
| FSF0364QB | 45*67*8 HTGR(VMQ) Brown | 010 997 3347 | 45 | 67 | | 8 | |
| FSF0594NB | 45*67*8 SC | | 45 | 67 | | 8 | |
| FSF0630NB | 45*67*10 TC | | 45 | 67 | | 10 | |
| FSF0099NB | 45*67/72*12 HTCR5 | 120 997 03 46A | 45 | 67 | 72 | 12 | |
| FSF0099FB | 45*67/72*12 HTCR5 (FKM) | 120 997 03 46A 咖啡色 | 45 | 67 | 72 | 12 | |
| FSF0748NB | 48*67*10 TC | | 48 | 67 | | 10 | |
| FSF0034NB | 48*67*14 KC9P(P7445) | | 48 | 67 | | 14 | |
| FSF0670NB | 50*67*5.5/7.5 KCY (Y) | 28015-AA011 | 50 | 67 | | 5.5 | 7.5 |
| FSF0370NB | 50*67*9 TB | 8-94433-718-0 | 50 | 67 | | 9 | |
| FSF0231NB | 50*67*9 TC | 8-94433-718-0 | 50 | 67 | | 9 | |
| FSF0101NB | 50*67*9/11 TCY | | 50 | 67 | | 9 | 11 |
| FSF0692NB | 50*67*9/13 KES-S | 7230-34040 | 50 | 67 | | 9 | 13 |
| FSF0625NB | 50*67*10 TC | | 50 | 67 | | 10 | |
| FSF0279NB | 50*67*11 KC3 | 43232-B5000,NJ387 | 50 | 67 | | 11 | |
| FSF0376NB | 50*67*11 TC | | 50 | 67 | | 11 | |
| FSF0554NB | 52*67*7 OTC | 40232-M5600 | 52 | 67 | | 7 | |
| FSF0697NB | 52*67*10 SC | | 52 | 67 | | 10 | |
| FSF0693NB | 54*67*7 TC | | 54 | 67 | | 7 | |
| FSF0789NB | 55*67*10 TC | | 55 | 67 | | 10 | |
| FSF0612NB | 56*67*5 SB | | 56 | 67 | | 5 | |
| FSF0611NB | 57*67*5 SB | | 57 | 67 | | 5 | |
| FSF0361NB | 57*67*6 TC | 62300-2020 | 57 | 67 | | 6 | |
| FSF0688NB | 57*67*7 TC | | 57 | 67 | | 7 | |
| FSF9850NB | 38.71*67.46/76.2*10.77 HTB5L Blue Painting | 15306 | 38.71 | 67.46 | 76.2 | 10.77 | |
| FSF0232NB | 50*67.5*8/13.5 TA2 | 005 997 44 47A | 50 | 67.5 | | 8 | 13.5 |
| FSF0674NB | 50*67.5*13.5/8 Y | | 50 | 67.5 | | 13.5 | 8 |
| FSF9849NB | 38.71*67.52/75.01*15.70 TBC5 Blue Painting | 15305P | 38.71 | 67.52 | 75.01 | 15.7 | |
| FSF0865FB | 30*68*7 TC(VITON) | | 30 | 68 | | 7 | |
| FSF0379NB | 30*68*8 TC | | 30 | 68 | | 8 | |
| FSF0732NB | 30*68*10 TC | | 30 | 68 | | 10 | |
| FSF0608NB | 32*68*8 TC | | 32 | 68 | | 8 | |
| FSF0822NB | 35*68*8 SC | | 35 | 68 | | 8 | |
| FSF0458NB | 35*68*8 TC | | 35 | 68 | | 8 | |
| FSF0726NB | 35*68*9/12.5 HTC9L | | 35 | 68 | | 9 | 12.5 |
| FSF0139NB | 35*68*9/15.5 HTCY | 90043-11105 | 35 | 68 | | 9 | 15.5 |
| FSF0144NB | 35*68*9/15.5 TCY(TC9Y) | 90043-11105 | 35 | 68 | | 9 | 15.5 |
| FSF0385NB | 35*68*10 TC | | 35 | 68 | | 10 | |
| FSF0779NB | 35*68*12 TC | | 35 | 68 | | 12 | |
| FSF0895NB | 35.8*68*10 SC | | 35.8 | 68 | | 10 | |
| FSF0107NB | 36*68*10 TB | | 36 | 68 | | 10 | |
| FSF0167NB | 36*68*10 TC | | 36 | 68 | | 10 | |
| FSF0678NB | 38*68*8 TC | | 38 | 68 | | 8 | |
| FSF0617NB | 38*68*10 TC | | 38 | 68 | | 10 | |
| FSF0156NB | 39*68*9/15.5 HTCR(HTC9R) | 90043-11260 | 39 | 68 | | 9 | 15.5 |
| FSF0157NB | 39*68*16/22.5 HTCR(HTG9R) | 90043-11271 | 39 | 68 | | 16 | 22.5 |
| FSF9821NB | 39.42*68/80.26*7.1/17.6 TB59Y | | 39.42 | 68 | 80.26 | 7.1 | 17.6 |
| FSF0556NB | 40*68*7 TC | | 40 | 68 | | 7 | |
| FSF0310NB | 40*68*8 TC | | 40 | 68 | | 8 | |
| FSF0166NB | 40*68*10 SA | | 40 | 68 | | 10 | |
| FSF0165NB | 40*68*10 SB | | 40 | 68 | | 10 | |
| FSF0033NB | 40*68*10 TC | | 40 | 68 | | 10 | |

| WLK CODE | OIL SEALS | DESCRIPTION | ID | OD1 | OD2 | H1 | H2 |
|-----------|-----------------------|--------------------------|----|-----|-----|------|------|
| FSF0033FB | 40*68*10 TC(VITON) | | 40 | 68 | | 10 | |
| FSF0601NB | 40*68*11 TB | | 40 | 68 | | 11 | |
| FSF0570NB | 40*68*11 TC | | 40 | 68 | | 11 | |
| FSF0295NB | 40*68*12 TC | | 40 | 68 | | 12 | |
| FSF0708NB | 42*68*8 TC | | 42 | 68 | | 8 | |
| FSF0396NB | 42*68*10 TC | | 42 | 68 | | 10 | |
| FSF0396FB | 42*68*10 TC(VITON) | | 42 | 68 | | 10 | |
| FSF0772NB | 42*68*12 TC | | 42 | 68 | | 12 | |
| FSF0614NB | 42*68*14.5/19.5 UES9 | | 42 | 68 | | 14.5 | 19.5 |
| FSF0742NB | 43*68*8 TC | | 43 | 68 | | 8 | |
| FSF0687NB | 44*68*8 HTCL(BROWN) | 91207-P0X-003/4 | 44 | 68 | | 8 | |
| FSF0746NB | 44*68*8 TC | | 44 | 68 | | 8 | |
| FSF0855NB | 44*68*12 SB | | 44 | 68 | | 12 | |
| FSF0819NB | 44*68*12.5 SC | | 44 | 68 | | 12.5 | |
| FSF0718NB | 44*68*12.8 SC | | 44 | 68 | | 12.8 | |
| FSF0403NB | 45*68*7 TC | BROWN | 45 | 68 | | 7 | |
| FSF0532NB | 45*68*8 TC | | 45 | 68 | | 8 | |
| FSF0804NB | 45*68*8.5 HTCR | | 45 | 68 | | 8.5 | |
| FSF0538NB | 45*68*9 HTCR | | 45 | 68 | | 9 | |
| FSF0296NB | 45*68*9 TC | | 45 | 68 | | 9 | |
| FSF0296FB | 45*68*9 TC(VITON) | | 45 | 68 | | 9 | |
| FSF0539NB | 45*68*9/14 HTC9R | | 45 | 68 | | 9 | 14 |
| FSF0404NB | 45*68*10 TC | | 45 | 68 | | 10 | |
| FSF0275NB | 45*68*12 HTCR | 13510-E0700, 13042-32200 | 45 | 68 | | 12 | |
| FSF0275QB | 45*68*12 HTCR(VMQ) | | 45 | 68 | | 12 | |
| FSF0032NB | 45*68*12 TC | AL2曲軸 9031145002/08/69 | 45 | 68 | | 12 | |
| FSF0032FU | 45*68*12 TC (FKM)S316 | (VITON)SUS316 SPRING | 45 | 68 | | 12 | |
| FSF0210NB | 45*68*12 TC3 | 33111-44001 | 45 | 68 | | 12 | |
| FSF0665NB | 45*68*12 TCN(NBR85) | AP2668G | 45 | 68 | | 12 | |
| FSF0312NB | 45*68*12 TZ | AS45 68 12 | 45 | 68 | | 12 | |
| FSF0211NB | 45*68*12.5/19 TC9 | 90043-11147 | 45 | 68 | | 12.5 | 19 |
| FSF0464NB | 46*68*10 TC | | 46 | 68 | | 10 | |
| FSF0641NB | 48*68/110*6/13 TGA5Y | 03AT86 | 48 | 68 | 110 | 6 | 13 |
| FSF0301NB | 48*68*7 HTCR | 90311-48014 | 48 | 68 | | 7 | |
| FSF0301QB | 48*68*7 HTCR(VMQ) | BH4214E | 48 | 68 | | 7 | |
| FSF0313QB | 48*68*7 TC(VMQ) | BH4214E | 48 | 68 | | 7 | |
| FSF0270NB | 48*68*8 TC | | 48 | 68 | | 8 | |
| FSF0223NB | 48*68*9 TC | | 48 | 68 | | 9 | |
| FSF0840NB | 48*68*10 SB | | 48 | 68 | | 10 | |
| FSF0415NB | 48*68*10 TC | | 48 | 68 | | 10 | |
| FSF0598NB | 48*68*11 HTC3R | MD-020308 | 48 | 68 | | 11 | |
| FSF0892NB | 48*68*12 SC | | 48 | 68 | | 12 | |
| FSF0831NB | 48*68*12 TC | | 48 | 68 | | 12 | |
| FSF0773NB | 48*68*14 TC | | 48 | 68 | | 14 | |
| FSF0939NB | 49*68*12 SC | | 49 | 68 | | 12 | |
| FSF0651NB | 50*68*7 TC | | 50 | 68 | | 7 | |
| FSF0651FB | 50*68*7 TC(VITON)FKM | | 50 | 68 | | 7 | |
| FSF0910NB | 50*68*7/10.5 TBY | | 50 | 68 | | 7 | 10.5 |
| FSF0255NB | 50*68*7/9 TB71 | 09283-50001 | 50 | 68 | | 7 | 9 |
| FSF0655NB | 50*68*8 SC | | 50 | 68 | | 8 | |
| FSF0655FB | 50*68*8 SC(VITON) | TC修掉副唇 | 50 | 68 | | 8 | |
| FSF0233NB | 50*68*8 TC | | 50 | 68 | | 8 | |
| FSF0233FB | 50*68*8 TC(VITON) | | 50 | 68 | | 8 | |
| FSF0126NB | 50*68*9 TA | 90311-50005 | 50 | 68 | | 9 | |
| FSF0602NB | 50*68*9 TB | | 50 | 68 | | 9 | |
| FSF0031NB | 50*68*9 TC | TS70/80 CRANK SHAFT | 50 | 68 | | 9 | |
| FSF0106NB | 50*68*9 TC3 | 9-09924-296-0 | 50 | 68 | | 9 | |

| WLK CODE | OIL SEALS | DESCRIPTION | ID | OD1 | OD2 | H1 | H2 |
|-----------|-----------------------------|--------------------------|-------|-------|------|------|------|
| FSF0562NB | 50*68*9/14.5 HTC9R | 90311-50017 | 50 | 68 | | 9 | 14.5 |
| FSF0235FB | 50*68*10 HSCR (FKM) | | 50 | 68 | | 10 | |
| FSF0235QB | 50*68*10 HSCR(VMQ) | | 50 | 68 | | 10 | |
| FSF0235NB | 50*68*10 HTCR | | 50 | 68 | | 10 | |
| FSF0325AB | 50*68*10 HTCR(ACM) | | 50 | 68 | | 10 | |
| FSF0827QB | 50*68*10 HTCR(VMQ) | | 50 | 68 | | 10 | |
| FSF0920FB | 50*68*10 SC(VITON) | | 50 | 68 | | 10 | |
| FSF0234NB | 50*68*10 TC | | 50 | 68 | | 10 | |
| FSF0640NB | 50*68*12 SC | | 50 | 68 | | 12 | |
| FSF0444NB | 50*68*12 TC | | 50 | 68 | | 12 | |
| FSF0030NB | 50*68*14.3 TC6Y(TC65) | 50*68/75*14.3 | 50 | 68 | | 14.3 | |
| FSF0341NB | 52*68*7 TC | | 52 | 68 | | 7 | |
| FSF0350NO | 52*68*7/13 KBY(KB9Y) | B001-33-065 | 52 | 68 | | 7 | 13 |
| FSF0029NB | 52*68*7/9 TBY | | 52 | 68 | | 7 | 9 |
| FSF0280NB | 52*68*7.5/12 TB9Y | 04422-20010, 40232-21B00 | 52 | 68 | | 7.5 | 12 |
| FSF0319NB | 52*68*8 TB | | 52 | 68 | | 8 | |
| FSF0241NB | 52*68*8 TC | | 52 | 68 | | 8 | |
| FSF0358NB | 52*68*8 TZ | | 52 | 68 | | 8 | |
| FSF0259NB | 52*68*8/11.7 TB9Y | | 52 | 68 | | 8 | 11.7 |
| FSF0446NB | 52*68*8/14 TB9 | | 52 | 68 | | 8 | 14 |
| FSF0609NB | 52*68*9 TC(Brown) | | 52 | 68 | | 9 | |
| FSF0357NB | 52*68*9 TZ | | 52 | 68 | | 9 | |
| FSF0242QB | 52*68*10 HTC (VMQ) | | 52 | 68 | | 10 | |
| FSF0463QB | 52*68*10 HTGR(VMQ)Brown | 11327 | 52 | 68 | | 10 | |
| FSF0373NB | 52*68*10 SC | | 52 | 68 | | 10 | |
| FSF0407NB | 52*68*10 TC | | 52 | 68 | | 10 | |
| FSF0407QB | 52*68*10 TC(VMQ) | | 52 | 68 | | 10 | |
| FSF0551NB | 52*68*13 SC | | 52 | 68 | | 13 | |
| FSF0583NB | 52*68*13 TC | | 52 | 68 | | 13 | |
| FSF0604NB | 52*68*13 TC3 | 40227-M56001/05 | 52 | 68 | | 13 | |
| FSF0028NB | 53*68*10 SB | | 53 | 68 | | 10 | |
| FSF0413NB | 53*68*10 TC | | 53 | 68 | | 10 | |
| FSF0483NB | 53*68*13 TC | | 53 | 68 | | 13 | |
| FSF0460NB | 54*68*8 TC | | 54 | 68 | | 8 | |
| FSF0756NB | 54*68*10 TC | | 54 | 68 | | 10 | |
| FSF0893NB | 54*68*10.5 SC | | 54 | 68 | | 10.5 | |
| FSF0797NB | 55*68*4 VG | | 55 | 68 | | 4 | |
| FSF0476NB | 55*68*8 SC | | 55 | 68 | | 8 | |
| FSF0843NB | 55*68*8 TA | | 55 | 68 | | 8 | |
| FSF0412NB | 55*68*8 TC | | 55 | 68 | | 8 | |
| FSF0412FB | 55*68*8 TC(VITON) | | 55 | 68 | | 8 | |
| FSF0278NB | 55*68/72.8*8/11.8 TB59 | 40232-50Y00, N2264 | 55 | 68 | 72.8 | 8 | 11.8 |
| FSF0417NB | 55*68*8.5 TC | | 55 | 68 | | 8.5 | |
| FSF0610NB | 55*68*9 TB | | 55 | 68 | | 9 | |
| FSF0561NB | 55*68*9 TC | | 55 | 68 | | 9 | |
| FSF0303NB | 55*68*10 TB | | 55 | 68 | | 10 | |
| FSF0499NB | 55*68*10 TC | | 55 | 68 | | 10 | |
| FSF0563NO | 56*68/74*5/10 KB59 | G304-33-065 | 56 | 68 | 74 | 5 | 10 |
| FSF0805NO | 58*68*4 VB | | 58 | 68 | | 4 | |
| FSF0512NB | 58*68*5 SB | | 58 | 68 | | 5 | |
| FSF0760NB | 58*68*9 TC | | 58 | 68 | | 9 | |
| FSF9948NB | 43.26*68.07*7.95 HSCL Brown | AH7689E | 43.26 | 68.07 | | 7.95 | |
| FSF0027NB | 53*68.15*10 SB | | 53 | 68.15 | | 10 | |
| FSF0285NB | 45*68.2*8.3 SCY | MD-711769 | 45 | 68.2 | | 8.3 | |
| FSF0243NB | 53*68.2*7 TC | 09283-53001 | 53 | 68.2 | | 7 | |
| FSF0520NB | 53*68.2*7 TCYI | Z6121 | 53 | 68.2 | | 7 | |
| FSF0112NB | 43*68.26*16/18.5 TC6Y | | 43 | 68.26 | | 16 | 18.5 |

| WLK CODE | OIL SEALS | DESCRIPTION | ID | OD1 | OD2 | H1 | H2 |
|-----------|-------------------------------|--------------------------|--------|-------|------|-------|-------|
| FSF9834NB | 44.45*68.26*16.5 TA4 Brown+ | NBR咖啡色+紅漆無商標 | 44.45 | 68.26 | | 16.5 | |
| FSF9858NB | 44.45*68.26*16.5 TC4 Brown | 無商標 | 44.45 | 68.26 | | 16.5 | |
| FSF9813NB | 50.8*68.26*9.52 TC | | 50.8 | 68.26 | | 9.52 | |
| FSF9838NB | 44.45*68.28*12.7 TC | | 44.45 | 68.28 | | 12.7 | |
| FSF9903NB | 47.63*68.28*9.53 TB | | 47.63 | 68.28 | | 9.53 | |
| FSF9868NB | 47.63*68.28*12.7 TA | | 47.63 | 68.28 | | 12.7 | |
| FSF9830NB | 49.23*68.28*7.95 TB | | 49.23 | 68.28 | | 7.95 | |
| FSF9810NB | 49.23*68.28*12.7 DC | | 49.23 | 68.28 | | 12.7 | |
| FSF9869NB | 49.23*68.28*12.7 TA | | 49.23 | 68.28 | | 12.7 | |
| FSF9885NB | 50.8*68.28*12.7 SC | | 50.8 | 68.28 | | 12.7 | |
| FSF0236NB | 50.8*68.32*12.7 SA2 | 2.000*2.690*0.500 SA2 | 50.8 | 68.32 | | 12.7 | |
| FSF0132NB | 43.48*68.4*16.25/20 TASCL | TASCL | 43.48 | 68.4 | | 16.25 | 20 |
| FSF9882NB | 47.88*68.58/76.2*14.68 HTB5LR | HTB5LR | 47.88 | 68.58 | 76.2 | 14.68 | |
| FSF0445NB | 39*69*8/17 TBCY | | 39 | 69 | | 8 | 17 |
| FSF0741NB | 42*69*10 SC | | 42 | 69 | | 10 | |
| FSF0634NB | 47*69*10/16.5 HTB9L | BH5320E | 47 | 69 | | 10 | 16.5 |
| FSF0581NB | 48*69*10 TC | | 48 | 69 | | 10 | |
| FSF0698NB | 52*69*10 TC | | 52 | 69 | | 10 | |
| FSF0304NB | 54*69*7.5/9.5 YDS9(DC9Y) | 09283-54001 | 54 | 69 | | 7.5 | 9.5 |
| FSF0759NB | 55*69*8 TC | | 55 | 69 | | 8 | |
| FSF0899NB | 56*69*7.5/17.7 KC5Y | NBR70 | 56 | 69 | | 7.5 | 17.7 |
| FSF0705NB | 46*69.4*11/16 Y | | 46 | 69.4 | | 11 | 16 |
| FSF9951NB | 38.1*69.85*9.53 SC | | 38.1 | 69.85 | | 9.53 | |
| FSF9971NB | 38.1*69.85*9.53 TC | | 38.1 | 69.85 | | 9.53 | |
| FSF9853NB | 39.42*69.85*6.76/15.09 HTB5W | w/sealant | 39.42 | 69.85 | | 6.76 | 15.09 |
| FSF9901NB | 41.28*69.85*6.35 TB | | 41.28 | 69.85 | | 6.35 | |
| FSF9930NB | 41.28*69.85*7.95 TA | | 41.28 | 69.85 | | 7.95 | |
| FSF9828NB | 41.28*69.85*9.53 TC | | 41.28 | 69.85 | | 9.53 | |
| FSF9822NB | 41.28*69.85*12.7 SC | | 41.28 | 69.85 | | 12.7 | |
| FSF9962NB | 44.45*69.85*7.93 SC | | 44.45 | 69.85 | | 7.93 | |
| FSF9820NB | 44.45*69.85*7.93 TB | | 44.45 | 69.85 | | 7.93 | |
| FSF9985NB | 44.45*69.85*7.95 TC | 1.750*2.750*0.313 TC | 44.45 | 69.85 | | 7.95 | |
| FSF9985FB | 44.45*69.85*7.95 TC(FKM) | 1.750*2.750*0.313 TC(VIT | 44.45 | 69.85 | | 7.95 | |
| FSF0531NB | 44.45*69.85*9.398 TB | 1.750*2.750*0.370 TB | 44.45 | 69.85 | | 9.398 | |
| FSF9905NB | 44.45*69.85*9.53 TB | | 44.45 | 69.85 | | 9.53 | |
| FSF9906NB | 44.45*69.85*9.53 TC | 1.750*2.750*0.375 TC | 44.45 | 69.85 | | 9.53 | |
| FSF9832NB | 44.45*69.85*12.7 TA | | 44.45 | 69.85 | | 12.7 | |
| FSF9917NB | 44.45*69.85*12.7 TB | 1.750*2.750*0.500 TB | 44.45 | 69.85 | | 12.7 | |
| FSF9946NB | 44.45*69.85*12.7 TC | 1.750*2.750*0.500 TC | 44.45 | 69.85 | | 12.7 | |
| FSF9875NB | 46.05*69.85*9.53 TC | | 46.05 | 69.85 | | 9.53 | |
| FSF9984NB | 47.625*69.85*7.95 TB | 1.875*2.750*0.313 TB | 47.625 | 69.85 | | 7.95 | |
| FSF9959NB | 47.63*69.85*7.95 TB | | 47.63 | 69.85 | | 7.95 | |
| FSF9958NB | 47.63*69.85*9.53 TC | | 47.63 | 69.85 | | 9.53 | |
| FSF9863NB | 47.63*69.85*12.7 TB | | 47.63 | 69.85 | | 12.7 | |
| FSF9859NB | 49.21*69.85*9.52 SC | | 49.21 | 69.85 | | 9.52 | |
| FSF9956NB | 49.21*69.85*12.7 SA | | 49.21 | 69.85 | | 12.7 | |
| FSF0224NB | 49.23*69.85*9.4 TC | 1.938*2.750*0.370 TC | 49.23 | 69.85 | | 9.4 | |
| FSF9842NB | 49.23*69.85*9.53 TB | 1.938*2.750*0.375 TB | 49.23 | 69.85 | | 9.53 | |
| FSF9949NB | 49.23*69.85*9.53 TC | | 49.23 | 69.85 | | 9.53 | |
| FSF9949FB | 49.23*69.85*9.53 TC(VITO | VITON | 49.23 | 69.85 | | 9.53 | |
| FSF9888NB | 50.8*69.85*6.35 TC | | 50.8 | 69.85 | | 6.35 | |
| FSF9912NB | 50.8*69.85*7.95 SB | | 50.8 | 69.85 | | 7.95 | |
| FSF9953NB | 50.8*69.85*7.95 TB | | 50.8 | 69.85 | | 7.95 | |
| FSF9953FB | 50.8*69.85*7.95 TB(VITON | | 50.8 | 69.85 | | 7.95 | |
| FSF9952NB | 50.8*69.85*7.95 TC | | 50.8 | 69.85 | | 7.95 | |
| FSF9952FB | 50.8*69.85*7.95 TC(VITON | | 50.8 | 69.85 | | 7.95 | |
| FSF9892NB | 50.8*69.85*9.53 TB | | 50.8 | 69.85 | | 9.53 | |

| WLK CODE | OIL SEALS | DESCRIPTION | ID | OD1 | OD2 | H1 | H2 |
|-----------|---------------------------|----------------------|-------|-------|-----|------|----|
| FSF9872NB | 50.8*69.85*9.53 TC | | 50.8 | 69.85 | | 9.53 | |
| FSF0462QB | 50.8*69.85*11 HTCLK(VMQ) | | 50.8 | 69.85 | | 11 | |
| FSF9873NB | 50.8*69.85*12.7 TC | | 50.8 | 69.85 | | 12.7 | |
| FSF9926NB | 53.98*69.85*9.53 TB | | 53.98 | 69.85 | | 9.53 | |
| FSF0418NB | 27*70*9/19 SPY | ELECTROLUX used | 27 | 70 | | 9 | 19 |
| FSF0699NB | 28*70*10 TC | | 28 | 70 | | 10 | |
| FSF0793NB | 30*70*8.5 TC | | 30 | 70 | | 8.5 | |
| FSF0544NB | 30*70*10 TC | | 30 | 70 | | 10 | |
| FSF0908NB | 32*70*8 TC | | 32 | 70 | | 8 | |
| FSF0593NB | 32*70*10 TC | | 32 | 70 | | 10 | |
| FSF0605NB | 34*70*10 TC | | 34 | 70 | | 10 | |
| FSF0677NB | 35*70*8 TC | | 35 | 70 | | 8 | |
| FSF0386NB | 35*70*10 TC | | 35 | 70 | | 10 | |
| FSF0386FB | 35*70*10 TC(VITON) | | 35 | 70 | | 10 | |
| FSF0727NB | 38*70*7 TC | | 38 | 70 | | 7 | |
| FSF0389NB | 38*70*10 TC | | 38 | 70 | | 10 | |
| FSF0334NB | 40*70*8 SC | | 40 | 70 | | 8 | |
| FSF0311NB | 40*70*8 TC | | 40 | 70 | | 8 | |
| FSF0311FB | 40*70*8 TC(VITON) | | 40 | 70 | | 8 | |
| FSF0302NB | 40*70*8/10 TC6Y(Brown) | BE3309E | 40 | 70 | | 8 | 10 |
| FSF0330NB | 40*70*8/15 TBCU9Y | | 40 | 70 | | 8 | 15 |
| FSF0393NB | 40*70*10 TC | | 40 | 70 | | 10 | |
| FSF0615NB | 40*70/80*10.5/15 TG5Y | 385 ; 113AE05 | 40 | 70 | 80 | 10.5 | 15 |
| FSF0507NB | 40*70*12 TC | | 40 | 70 | | 12 | |
| FSF0360NB | 40*70*12/16 HTBC(ACM) | 014 997 49 47A(2593) | 40 | 70 | | 12 | 16 |
| FSF0258NB | 40*70/80*12/14 Y(VCA5Y) | Aeg, Universal | 40 | 70 | 80 | 12 | 14 |
| FSF0914NB | 42*70*8 TC | | 42 | 70 | | 8 | |
| FSF0397NB | 42*70*10 TC | | 42 | 70 | | 10 | |
| FSF0441NB | 42*70*12 TC | | 42 | 70 | | 12 | |
| FSF0743NB | 43*70*12 TB | | 43 | 70 | | 12 | |
| FSF0721NB | 44*70*10 TC | | 44 | 70 | | 10 | |
| FSF0184N0 | 45*70*5 VC | | 45 | 70 | | 5 | |
| FSF0018NB | 45*70*8.5 TC | | 45 | 70 | | 8.5 | |
| FSF0025NB | 45*70*10 TC | | 45 | 70 | | 10 | |
| FSF0025FB | 45*70*10 TC(VITON) | | 45 | 70 | | 10 | |
| FSF0763NB | 45*70*10 TCV(NBR80) | | 45 | 70 | | 10 | |
| FSF0017NB | 45*70*12 TC | AEL 曲軸 | 45 | 70 | | 12 | |
| FSF0017NS | 45*70*12 TC (S304 SPRING) | | 45 | 70 | | 12 | |
| FSF0649NB | 45*70*12/19 HTC9L | MT045A3 | 45 | 70 | | 12 | 19 |
| FSF0287NB | 45*70*15 DC(BROWN) | | 45 | 70 | | 15 | |
| FSF0449NB | 46*70*8 TC | | 46 | 70 | | 8 | |
| FSF0928NB | 46*70*10 TC | | 46 | 70 | | 10 | |
| FSF0689NB | 47*70*8 TC | | 47 | 70 | | 8 | |
| FSF0016NB | 47*70*9 TC | | 47 | 70 | | 9 | |
| FSF0021NB | 47*70*9.5 TB3 | | 47 | 70 | | 9.5 | |
| FSF0528NB | 47*70*10 TC | | 47 | 70 | | 10 | |
| FSF0346NB | 47*70*12 TC | | 47 | 70 | | 12 | |
| FSF0432NB | 48*70*8 TC | | 48 | 70 | | 8 | |
| FSF0277NB | 48*70*9 HTC3R | 13042-A3510 | 48 | 70 | | 9 | |
| FSF0015NB | 48*70*9 SC | ER20曲軸油封 | 48 | 70 | | 9 | |
| FSF0024NB | 48*70*9 TC | 0603-26-157 | 48 | 70 | | 9 | |
| FSF0024FB | 48*70*9 TC(VITON) | | 48 | 70 | | 9 | |
| FSF0279NB | 48*70*9.5 TB3 | 9-09724-054-0/640 | 48 | 70 | | 9.5 | |
| FSF0248NB | 48*70*10 TA | | 48 | 70 | | 10 | |
| FSF0249NB | 48*70*10 TB | | 48 | 70 | | 10 | |
| FSF0250NB | 48*70*10 TC | 02211-10-603 | 48 | 70 | | 10 | |
| FSF0012NB | 48*70*12 HTC | | 48 | 70 | | 12 | |

| WLK CODE | OIL SEALS | DESCRIPTION | ID | OD1 | OD2 | H1 | H2 |
|-----------|--------------------------|--------------------------|----|-----|-----|------|------|
| FSG0307NB | 48*70*12 HTCR | 0221-10-602 | 48 | 70 | | 12 | |
| FSF0014NB | 48*70*12 TC | M11/130 曲軸, NM130起動 | 48 | 70 | | 12 | |
| FSF0807NB | 48*70*12 TZ | | 48 | 70 | | 12 | |
| FSF0105NB | 48*70/94*12.5 SBY | 圓形有4個洞 | 48 | 70 | 94 | 12.5 | |
| FSF0663NB | 48*70*13/18 TB9 | | 48 | 70 | | 13 | 18 |
| FSF0924NB | 48*70*13/19 TB9Y | | 48 | 70 | | 13 | 19 |
| FSF0306NB | 48*70*18 DB | | 48 | 70 | | 18 | |
| FSF0810NB | 49*70*9.5 SC | | 49 | 70 | | 9.5 | |
| FSG0333NB | 49*70/77*12/16.5 TB359 | | 49 | 70 | 77 | 12 | 16.5 |
| FSF0806NB | 50*70*7 TA | | 50 | 70 | | 7 | |
| FSF0587NB | 50*70*7/9.5 TAY | 5-42316-010-0 | 50 | 70 | | 7 | 9.5 |
| FSF0671NB | 50*70*7/9.5 TBY | | 50 | 70 | | 7 | 9.5 |
| FSF0623NB | 50*70*8 SC | | 50 | 70 | | 8 | |
| FSF0911NB | 50*70*8 TB | | 50 | 70 | | 8 | |
| FSF0435NB | 50*70*8 TC | | 50 | 70 | | 8 | |
| FSF0011NB | 50*70*9 TA | | 50 | 70 | | 9 | |
| FSF0175NB | 50*70*9 TB | 90310-50039/01 | 50 | 70 | | 9 | |
| FSF0023NB | 50*70*9 TC | | 50 | 70 | | 9 | |
| FSF0023FB | 50*70*9 TC(VITON) | | 50 | 70 | | 9 | |
| FSF0008NB | 50*70*10 SB | | 50 | 70 | | 10 | |
| FSF0790NB | 50*70*10 SC | | 50 | 70 | | 10 | |
| FSF0790FB | 50*70*10 SC(VITON) | | 50 | 70 | | 10 | |
| FSF0147NB | 50*70*10 TB | | 50 | 70 | | 10 | |
| FSF0009NB | 50*70*10 TB3 | | 50 | 70 | | 10 | |
| FSF0010NB | 50*70*10 TC | KND70/90 曲軸ER13 | 50 | 70 | | 10 | |
| FSF0010QB | 50*70*10 TC (VMQ) | | 50 | 70 | | 10 | |
| FSF0010FB | 50*70*10 TC(VITON) | | 50 | 70 | | 10 | |
| FSF0440NB | 50*70*10 TZ | | 50 | 70 | | 10 | |
| FSF0606NB | 50*70*10/16 HTC9R | 90311-50014 | 50 | 70 | | 10 | 16 |
| FSF0283NB | 50*70*11 HTCL | | 50 | 70 | | 11 | |
| FSF0007NB | 50*70*11 TC | | 50 | 70 | | 11 | |
| FSF0006NB | 50*70*12 HTCL | | 50 | 70 | | 12 | |
| FSF0005NB | 50*70*12 SC | | 50 | 70 | | 12 | |
| FSF0503NB | 50*70*12 TC | | 50 | 70 | | 12 | |
| FSF0503NS | 50*70*12 TC(S304 SPRING) | S304 SPRING | 50 | 70 | | 12 | |
| FSF0503FB | 50*70*12 TC(VITON) | | 50 | 70 | | 12 | |
| FSF0503QB | 50*70*12 TC(VMQ) | | 50 | 70 | | 12 | |
| FSF0286NB | 50*70*12/17 TB359 | 43232-01G00 | 50 | 70 | | 12 | 17 |
| FSF0257NB | 50*70*13.5 TBN | 010 997 6747A雙個組合 | 50 | 70 | | 13.5 | |
| FSF0811NB | 50*70*14 TC | | 50 | 70 | | 14 | |
| FSF0516NB | 51*70*11 HTCR | 0636-10-602,SE-08-10-602 | 51 | 70 | | 11 | |
| FSF0753NB | 52*70*7 TC | | 52 | 70 | | 7 | |
| FSF0703NB | 52*70*7.5 OTB | | 52 | 70 | | 7.5 | |
| FSF0374NB | 52*70*8 TC | | 52 | 70 | | 8 | |
| FSF0465NB | 52*70*8.5 HTCR | | 52 | 70 | | 8.5 | |
| FSF0465QB | 52*70*8.5 HTCR(VMQ) | | 52 | 70 | | 8.5 | |
| FSF0842NB | 52*70*8.5/14 HTC9(BROWN) | AH2576G | 52 | 70 | | 8.5 | 14 |
| FSF0251NB | 52*70*9 TB | S113-33-067;9958-55-2709 | 52 | 70 | | 9 | |
| FSF0004NB | 52*70*9 TC | TS105 CRANK SHAFT | 52 | 70 | | 9 | |
| FSF0004FB | 52*70*9 TC(VITON) | | 52 | 70 | | 9 | |
| FSF0925NB | 52*70*9/14 HTC9R | | 52 | 70 | | 9 | 14 |
| FSF0408NB | 52*70*10 TC | | 52 | 70 | | 10 | |
| FSF0408FB | 52*70*10 TC(VITON) | | 52 | 70 | | 10 | |
| FSF0588NB | 52*70*13 SC | | 52 | 70 | | 13 | |
| FSF0022NB | 54*70*7/9.5 TA | 8-94227-048-1 | 54 | 70 | | 7 | 9.5 |
| FSF0564NB | 54*70*8 TC | | 54 | 70 | | 8 | |
| FSF0780NB | 54*70*9 TC | | 54 | 70 | | 9 | |

| WLK CODE | OIL SEALS | DESCRIPTION | ID | OD1 | OD2 | H1 | H2 |
|-----------|-------------------------------------|--------------------------|-------|-------|-------|-------|------|
| FSF0359NB | 54*70*10 TC | | 54 | 70 | | 10 | |
| FSF0020NB | 54.8*70*7/9 TCY(ASL) | | 54.8 | 70 | | 7 | 9 |
| FSF0019NB | 54.8*70*9 TC | | 54.8 | 70 | | 9 | |
| FSF0252NB | 55*70*7 TC | | 55 | 70 | | 7 | |
| FSF0003NB | 55*70*8 SC | | 55 | 70 | | 8 | |
| FSF0003FB | 55*70*8 SC(VITON) | TC修掉副唇 | 55 | 70 | | 8 | |
| FSF0410NB | 55*70*8 TC | | 55 | 70 | | 8 | |
| FSF0410QB | 55*70*8 TC (VMQ) | | 55 | 70 | | 8 | |
| FSF0410FB | 55*70*8 TC(VITON) | | 55 | 70 | | 8 | |
| FSF0525NB | 55*70*9 TB | | 55 | 70 | | 9 | |
| FSF0253NB | 55*70*9 TC | 32136-C0400 | 55 | 70 | | 9 | |
| FSF0254QB | 55*70*10 SC (VMQ) | (VMQ) | 55 | 70 | | 10 | |
| FSF0254FB | 55*70*10 SC(VITON) | | 55 | 70 | | 10 | |
| FSF0002NB | 55*70*10 TC | | 55 | 70 | | 10 | |
| FSF0002FB | 55*70*10 TC(VITON) | | 55 | 70 | | 10 | |
| FSF0260NB | 55*70*12 TC | | 55 | 70 | | 12 | |
| FSF0681NB | 56*70*8 TC | | 56 | 70 | | 8 | |
| FSF0681FB | 56*70*8 TC(VITON) | | 56 | 70 | | 8 | |
| FSF0001NB | 56*70*9 TC | TS130 CRANK SHAFT | 56 | 70 | | 9 | |
| FSF0256NB | 56*70*9/10 TCV Blue | | 56 | 70 | | 9 | 10 |
| FSG0302NB | 58*70*7 TB | | 58 | 70 | | 7 | |
| FSG0581NB | 58*70*8 TC | | 58 | 70 | | 8 | |
| FSF0761NB | 58*70*10 TC | | 58 | 70 | | 10 | |
| FSF0675NB | 60*70*7 SC | | 60 | 70 | | 7 | |
| FSF0762NB | 60*70*7 TC | | 60 | 70 | | 7 | |
| FSG0304NB | 60*70*7/10 DK1 | | 60 | 70 | | 7 | 10 |
| FSF0474NB | 60*70*8 TC | | 60 | 70 | | 8 | |
| FSF0340NB | 60*70*10 TC | | 60 | 70 | | 10 | |
| FSF0026NB | 62.3*70*5/6.5 L | | 62.3 | 70 | | 5 | 6.5 |
| FSI0052N0 | 100*70*12 X3 | | 100 | 70 | | 12 | |
| PMI0052C | 100*70*12 X3 (鐵殼) | WEAR RING | 100 | 70 | | 12 | |
| FSG0143NB | 55*70.25*6/10.3 HTCY | | 55 | 70.25 | | 6 | 10.3 |
| FSG9883NB | 46.05*70.53/79.18*11.51/13.89 HTB5R | Blue Painting | 46.05 | 70.53 | 79.18 | 11.51 | |
| FSG9972NB | 47.6*70.6*9 TC3 | | 47.6 | 70.6 | | 9 | |
| FSG0115NB | 47.6*70.64*13.5 TB3 | 90311-47029T | 47.6 | 70.64 | | 13.5 | |
| FSG0114NB | 47.5*70.65*9 TC | 90311-47001/48 | 47.5 | 70.65 | | 9 | |
| FSG0718NB | 39*71/80*6/16 TB59Y | | 39 | 71 | 80 | 6 | 16 |
| FSG0582NB | 48*71/80.2*14/20.5 HTB59Y | Orange Painting | 48 | 71 | 80.2 | 14 | 20.5 |
| FSG0698NB | 52*71*9 SC | | 52 | 71 | | 9 | |
| FSG0377NB | 56*71/77.7*6.5/14 TB59Y | 04422-10020-56 | 56 | 71 | 77.7 | 6.5 | 14 |
| FSG0560NB | 56*71*7.5/11.5 TB29 | | 56 | 71 | | 7.5 | 11.5 |
| FSG0623NB | 57*71*8 TC | | 57 | 71 | | 8 | |
| FSH9994NB | 39.42*71.04/80.26*13.46 TB59Y | | 39.42 | 71.04 | 80.26 | 13.46 | |
| FSG9993NB | 47.63*71.04/80.26*14.27 TB5 | 1.875*2.797/3.16*0.562TB | 47.63 | 71.04 | 80.26 | 14.27 | |
| FSH9941NB | 44.17*71.42/83.06*15.09 HTB5R | Blue Painting | 44.17 | 71.42 | 83.06 | 15.09 | |
| FSG0653NB | 20*72*5 SC | | 20 | 72 | | 5 | |
| FSG0674NB | 20*72*10 SC | | 20 | 72 | | 10 | |
| FSG0303NB | 25*72*7 SC (Blue 1) | | 25 | 72 | | 7 | |
| FSG0074NB | 25*72*7 TC | | 25 | 72 | | 7 | |
| FSG0072NB | 30*72*7 TB | | 30 | 72 | | 7 | |
| FSG0079NB | 30*72*8 TC | | 30 | 72 | | 8 | |
| FSG0237NB | 30*72*10 TC | | 30 | 72 | | 10 | |
| FSG0237FB | 30*72*10 TC(VITON) | | 30 | 72 | | 10 | |
| FSG0087NB | 30*72*11 TC | | 30 | 72 | | 11 | |
| FSG0414NB | 31.75*72*9.5 TC | | 31.75 | 72 | | 9.5 | |
| FSG0474NB | 32*72*8 TC | | 32 | 72 | | 8 | |

| WLK CODE | OIL SEALS | DESCRIPTION | ID | OD1 | OD2 | H1 | H2 |
|-----------|---------------------------|--------------------------|------|-----|-----|------|------|
| FSG0305NB | 32*72*10 TC | | 32 | 72 | | 10 | |
| FSG0194NB | 34*72*10 TC | | 34 | 72 | | 10 | |
| FSG0071NB | 34*72*11 TC | | 34 | 72 | | 11 | |
| FSG0503NB | 35*72*7 SC | | 35 | 72 | | 7 | |
| FSG0460NB | 35*72*7 TC | | 35 | 72 | | 7 | |
| FSG0095NB | 35*72*7.5/9.5 TC31 | 09283-35013 | 35 | 72 | | 7.5 | 9.5 |
| FSG0471NB | 35*72*8 TC | | 35 | 72 | | 8 | |
| FSG0471FB | 35*72*8 TC(VITON) | | 35 | 72 | | 8 | |
| FSG0070NB | 35*72*10 SC | | 35 | 72 | | 10 | |
| FSG0083NB | 35*72*10 TC | | 35 | 72 | | 10 | |
| FSG0083FB | 35*72*10 TC(VITON) | | 35 | 72 | | 10 | |
| FSG0432NB | 35*72*10/12 TG4 | 03AT43 | 35 | 72 | | 10 | 12 |
| FSG0527NB | 35*72/79*11/16 TG659Y | | 35 | 72 | 79 | 11 | 16 |
| FSG0526NB | 35*72/88*11/18 TC5Y | 03AG502 | 35 | 72 | 88 | 11 | 18 |
| FSG0069NB | 35*72*12 TC | | 35 | 72 | | 12 | |
| FSG0459NB | 35*72*12.5/16.5 TC9Y | | 35 | 72 | | 12.5 | 16.5 |
| FSG0068NB | 35*72/80*13 TC6Y | ER8Hp 主齒輪箱部牛腳 | 35 | 72 | 80 | 13 | |
| FSG0574NB | 36*72*7/9 DC | | 36 | 72 | | 7 | 9 |
| FSG0626NB | 36*72*12/16 Y | | 36 | 72 | | 12 | 16 |
| FSG0309NB | 38*72*8 TC(BLUE) | | 38 | 72 | | 8 | |
| FSG0227NB | 38*72*10 TC | | 38 | 72 | | 10 | |
| FSG0429NB | 38*72*11 TC | | 38 | 72 | | 11 | |
| FSG0642NB | 38*72*12 SB | | 38 | 72 | | 12 | |
| FSG0473NB | 38*72*12 TC | | 38 | 72 | | 12 | |
| FSG0688NB | 39.5*72/78*11/14.5 TG569Y | 587423 GORENJE | 39.5 | 72 | 78 | 11 | 14.5 |
| FSG0748FB | 40*72*7 SC(VITON) | | 40 | 72 | | 7 | |
| FSG0294NB | 40*72*7 TC | | 40 | 72 | | 7 | |
| FSG0225NB | 40*72*8 TC | | 40 | 72 | | 8 | |
| FSG0067NB | 40*72*10 SC | | 40 | 72 | | 10 | |
| FSG0085NB | 40*72*10 TC | | 40 | 72 | | 10 | |
| FSG0085FB | 40*72*10 TC(VITON) | | 40 | 72 | | 10 | |
| FSG0096NB | 40*72*10/17.5 TC9 | 09283-40013 | 40 | 72 | | 10 | 17.5 |
| FSG0662NB | 40*72*11/18 TC9 | 09283-40022 | 40 | 72 | | 11 | 18 |
| FSG0097NB | 40*72*12 TC | | 40 | 72 | | 12 | |
| FSG0097QB | 40*72*12 TC (VMQ) | | 40 | 72 | | 12 | |
| FSG0097FB | 40*72*12 TC(VITON) | | 40 | 72 | | 12 | |
| FSG0065NB | 40*72*12 TC6(TCU) | | 40 | 72 | | 12 | |
| FSG0323NB | 40*72*12/16 KC3Y | | 40 | 72 | | 12 | 16 |
| FSG0075NB | 40*72/77*12 TCY | 90043-11083 | 40 | 72 | 77 | 12 | |
| FSG0196NS | 40.2*72/80*8/13 TG5Y | 113ZN12 | 40.2 | 72 | 80 | 8 | 13 |
| FSG0102NB | 40.2*72*10/13.5 TGY(TCY) | Zanussi Rex, Electrolux, | 40.2 | 72 | | 10 | 13.5 |
| FSG0734NB | 42*72*6 TC | | 42 | 72 | | 6 | |
| FSG0585NB | 42*72*7 TC | | 42 | 72 | | 7 | |
| FSG0400NB | 42*72*8 SC | | 42 | 72 | | 8 | |
| FSG0416NB | 42*72*8 TC | | 42 | 72 | | 8 | |
| FSG0416FB | 42*72*8 TC(VITON) | | 42 | 72 | | 8 | |
| FSG0571NB | 42*72*9 TB | | 42 | 72 | | 9 | |
| FSG0064NB | 42*72*10 TB | | 42 | 72 | | 10 | |
| FSG0063NB | 42*72*10 TC | | 42 | 72 | | 10 | |
| FSG0673NB | 42*72*12 SB | | 42 | 72 | | 12 | |
| FSG0078NB | 42*72*12 TC | | 42 | 72 | | 12 | |
| FSG0078FB | 42*72*12 TC(VITON) | | 42 | 72 | | 12 | |
| FSG0644NB | 44*72*7 SC | | 44 | 72 | | 7 | |
| FSG0524NB | 44*72*10 SC | | 44 | 72 | | 10 | |
| FSG0479NB | 44*72*10 TC | | 44 | 72 | | 10 | |
| FSG0477NB | 44*72*12 TC | | 44 | 72 | | 12 | |
| FSG0153N0 | 45*72*5 VC | | 45 | 72 | | 5 | |

| WLK CODE | OIL SEALS | DESCRIPTION | ID | OD1 | OD2 | H1 | H2 |
|-----------|--------------------------|--------------------|----|-----|-----|-----|------|
| FSG0607NB | 45*72*7 TC | | 45 | 72 | | 7 | |
| FSG0357NB | 45*72*8 SC | | 45 | 72 | | 8 | |
| FSG0228NB | 45*72*8 TC | | 45 | 72 | | 8 | |
| FSG0228FB | 45*72*8 TC(VITON)FKM | | 45 | 72 | | 8 | |
| FSG0062NB | 45*72*10 TB | WHEEL FIAT TRACTOR | 45 | 72 | | 10 | |
| FSG0061NB | 45*72*10 TC | 90043-11114 | 45 | 72 | | 10 | |
| FSG0061FB | 45*72*10 TC(VITON)FKM | | 45 | 72 | | 10 | |
| FSG0631NB | 45*72*10/14.5 TC9(BROWN) | | 45 | 72 | | 10 | 14.5 |
| FSG0426NB | 45*72*11 DB | 16003 | 45 | 72 | | 11 | |
| FSG0421NB | 45*72*12 TB | | 45 | 72 | | 12 | |
| FSG0060NB | 45*72*12 TC | 90043-457212 | 45 | 72 | | 12 | |
| FSG0086NB | 45*72*12/16 KC3Y | | 45 | 72 | | 12 | 16 |
| FSG0386NB | 45*72*12/18 TC9 | 90043-11131-000 | 45 | 72 | | 12 | 18 |
| FSG0415NB | 45*72*12/19.5 HTB9R | AH2685H | 45 | 72 | | 12 | 19.5 |
| FSG0330NB | 45*72*12/19.5 HTB9W | 此油封是內徑倒三角 | 45 | 72 | | 12 | 19.5 |
| FSG0260NB | 45*72*12/20.5 HTB9R | MB-160949 | 45 | 72 | | 12 | 20.5 |
| FSG0108NB | 45*72*15 HTC4 | 091 301 189 | 45 | 72 | | 15 | |
| FSF0916NB | 46*72*7 TC | | 46 | 72 | | 7 | |
| FSF0917NB | 46*72*10 TC | | 46 | 72 | | 10 | |
| FSG0469NB | 47*72*10 SC | | 47 | 72 | | 10 | |
| FSG0564NB | 47*72*10 TC | | 47 | 72 | | 10 | |
| FSG0515NB | 48*72*7 TC | | 48 | 72 | | 7 | |
| FSG0059NB | 48*72*7/9 TC6Y | | 48 | 72 | | 7 | 9 |
| FSG0706FB | 48*72*8 SC(VITON) | | 48 | 72 | | 8 | |
| FSG0121NB | 48*72*8 TC | 90311-48007/08 | 48 | 72 | | 8 | |
| FSG0121QB | 48*72*8 TC (VMQ) | | 48 | 72 | | 8 | |
| FSG0514NB | 48*72*8.5 TC | | 48 | 72 | | 8.5 | |
| FSG0058NB | 48*72*9 SC6Y | NM130 曲軸 GJ7536P | 48 | 72 | | 9 | |
| FSG0122NB | 48*72*9 TC | 90311-48007,NJ866 | 48 | 72 | | 9 | |
| FSG0057NB | 48*72*10 TC | | 48 | 72 | | 10 | |
| FSG0057FB | 48*72*10 TC(VITON) | | 48 | 72 | | 10 | |
| FSG0447NB | 48*72*11 DC(Brown) | 90316-48003 | 48 | 72 | | 11 | |
| FSG0123NB | 48*72*12 TC | | 48 | 72 | | 12 | |
| FSG0127NB | 49*72*10 SC | | 49 | 72 | | 10 | |
| FSG0142N0 | 50*72*5 VC | | 50 | 72 | | 5 | |
| FSG0337NB | 50*72*7 TC | | 50 | 72 | | 7 | |
| FSG0337FB | 50*72*7 TC(VITON) | | 50 | 72 | | 7 | |
| FSG0442NB | 50*72*7 TCV(NBR Blue 80 | | 50 | 72 | | 7 | |
| FSG0731FB | 50*72*7/7.5 TCV(VITON) | | 50 | 72 | | 7 | 7.5 |
| FSG0130NB | 50*72*8 SB | | 50 | 72 | | 8 | |
| FSG0428FB | 50*72*8 SC(VITON)FKM | | 50 | 72 | | 8 | |
| FSG0466NB | 50*72*8 TB | | 50 | 72 | | 8 | |
| FSG0234NB | 50*72*8 TC | | 50 | 72 | | 8 | |
| FSG0234FB | 50*72*8 TC(VITON) | | 50 | 72 | | 8 | |
| FSG0234QB | 50*72*8 TC(VMQ) | | 50 | 72 | | 8 | |
| FSG0349NB | 50*72*8/11 TB9 | MB-303866 | 50 | 72 | | 8 | 11 |
| FSG0056NB | 50*72*8.5 TC | 90043-11082 | 50 | 72 | | 8.5 | |
| FSG0478NB | 50*72*9 TB | | 50 | 72 | | 9 | |
| FSG0392NB | 50*72*9 TC | 90043-11082-000 | 50 | 72 | | 9 | |
| FSG0458NB | 50*72*9/14 HTC9R | 90311-50013 | 50 | 72 | | 9 | 14 |
| FSG0505QB | 50*72*9/15.5 | AH2861E(VMQ)咖啡色 | 50 | 72 | | 9 | 15.5 |
| FSG0682FB | 50*72*10 SC(VITON) | | 50 | 72 | | 10 | |
| FSG0743NB | 50*72*10 TA | | 50 | 72 | | 10 | |
| FSG0519NB | 50*72*10 TB | | 50 | 72 | | 10 | |
| FSG0055NB | 50*72*10 TC | | 50 | 72 | | 10 | |
| FSG0055FB | 50*72*10 TC(VITON)FKM | | 50 | 72 | | 10 | |
| FSG0131NB | 50*72*12 HTCL | 2S THRUST SHAFT | 50 | 72 | | 12 | |

| WLK CODE | OIL SEALS | DESCRIPTION | ID | OD1 | OD2 | H1 | H2 |
|-----------|--------------------------|--------------------|------|-----|-----|------|-----|
| FSG0248NB | 50*72*12 HTCR | 90311-50006 | 50 | 72 | | 12 | |
| FSG0715NB | 50*72*12 SC(VITON) | 修掉副唇 | 50 | 72 | | 12 | |
| FSG0579NB | 50*72*12 TB | | 50 | 72 | | 12 | |
| FSG0054NB | 50*72*12 TC | KND180/220 曲軸 | 50 | 72 | | 12 | |
| FSG0054FB | 50*72*12 TC (FKM)VITON | | 50 | 72 | | 12 | |
| FSG0054NS | 50*72*12 TC(S304 SPRING) | SUS304 SPRING | 50 | 72 | | 12 | |
| FSG0054QB | 50*72*12 TC(VMQ) | | 50 | 72 | | 12 | |
| FSG0080NB | 50*72*12 TC4 | | 50 | 72 | | 12 | |
| FSG0488NB | 50*72*12 TCN(NBR90) | AP2864I | 50 | 72 | | 12 | |
| FSG0470NB | 50*72*12/17 TB9Y | | 50 | 72 | | 12 | 17 |
| FSG0578NB | 50*72*14 TB | | 50 | 72 | | 14 | |
| FSG0530NB | 50*72/83*16.2 Y | 40227-50W01 | 50 | 72 | 83 | 16.2 | |
| FSG0601NB | 51*72*10 SC | | 51 | 72 | | 10 | |
| FSG0640NB | 52*72*7/7.5 TCV | | 52 | 72 | | 7 | 7.5 |
| FSG0522NB | 52*72*7.5 TBP | 9-097240-220 | 52 | 72 | | 7.5 | |
| FSG0331NB | 52*72*7.5/16 TC9 | 90625-0015 | 52 | 72 | | 7.5 | 16 |
| FSG0314NB | 52*72*8 TC | | 52 | 72 | | 8 | |
| FSG0314FB | 52*72*8 TC(VITON) | | 52 | 72 | | 8 | |
| FSG0314QB | 52*72*8 TC(VMQ) | | 52 | 72 | | 8 | |
| FSG0531NB | 52*72*8/11 TB9 | MB-303875 | 52 | 72 | | 8 | 11 |
| FSG0053NB | 52*72*9 TC | 9828-55101/05 | 52 | 72 | | 9 | |
| FSG0053QB | 52*72*9 TC(VMQ) | | 52 | 72 | | 9 | |
| FSG0589NB | 52*72*10 SA | | 52 | 72 | | 10 | |
| FSG0073NB | 52*72*10 TC | | 52 | 72 | | 10 | |
| FSG0051NB | 52*72/82*11 TCY | EMG | 52 | 72 | 82 | 11 | |
| FSG0397QB | 52*72*12 HTGR(VMQ) | | 52 | 72 | | 12 | |
| FSG0136NB | 52*72*12 TB | | 52 | 72 | | 12 | |
| FSG0081NB | 52*72*12 TC | | 52 | 72 | | 12 | |
| FSG0081QB | 52*72*12 TC (VMQ) | | 52 | 72 | | 12 | |
| FSG0081FB | 52*72*12 TC(VITON) | | 52 | 72 | | 12 | |
| FSG0052NB | 52.2*72*10 TC | | 52.2 | 72 | | 10 | |
| FSG0696NB | 53*72*8 TC | | 53 | 72 | | 8 | |
| FSG0050NB | 53*72*10 TC | 久保 17/20馬耕耘軸大油封 | 53 | 72 | | 10 | |
| FSG0546NB | 54*72*5 SC | | 54 | 72 | | 5 | |
| FSG0648NB | 54*72*8 SC | | 54 | 72 | | 8 | |
| FSG0620NB | 54*72*8 TC | | 54 | 72 | | 8 | |
| FSG0358NB | 54*72*10 TC | | 54 | 72 | | 10 | |
| FSG0358FB | 54*72*10 TC(VITON) | | 54 | 72 | | 10 | |
| FSG0750NB | 55*72*7 TB | | 55 | 72 | | 7 | |
| FSG0393NB | 55*72*7 TC | | 55 | 72 | | 7 | |
| FSG0441NB | 55*72*7 TCV NBR Brown80 | | 55 | 72 | | 7 | |
| FSG0395NB | 55*72*8 SC | | 55 | 72 | | 8 | |
| FSG0395FB | 55*72*8 SC(VITON) | | 55 | 72 | | 8 | |
| FSG0205NB | 55*72*8 TC | | 55 | 72 | | 8 | |
| FSG0205FB | 55*72*8 TC(VITON) | | 55 | 72 | | 8 | |
| FSG0542NB | 55*72*9 HTCR | | 55 | 72 | | 9 | |
| FSG0363NB | 55*72*9 TB | 9958-55-5729 | 55 | 72 | | 9 | |
| FSG0048NB | 55*72*9 TC | TS130C CRANK SHAFT | 55 | 72 | | 9 | |
| FSG0048QB | 55*72*9 TC(VMQ) | | 55 | 72 | | 9 | |
| FSG0346NB | 55*72*9/15 TB9 | 9828-55110 | 55 | 72 | | 9 | 15 |
| FSG0144NB | 55*72*9/15 TC9 | | 55 | 72 | | 9 | 15 |
| FSG0047NB | 55*72*10 HTCL | | 55 | 72 | | 10 | |
| FSG0712NB | 55*72*10 SC | | 55 | 72 | | 10 | |
| FSG0749NB | 55*72*10 TB | | 55 | 72 | | 10 | |
| FSG0145NB | 55*72*10 TC | | 55 | 72 | | 10 | |
| FSG0145QB | 55*72*10 TC (VMQ) | | 55 | 72 | | 10 | |
| FSG0145FB | 55*72*10 TC(VITON)FKM | | 55 | 72 | | 10 | |

| WLK CODE | OIL SEALS | DESCRIPTION | ID | OD1 | OD2 | H1 | H2 |
|-----------|------------------------------------|----------------------|-------|-------|-------|------|-------|
| FSG0359NB | 55*72*12 TA | | 55 | 72 | | 12 | |
| FSG0046NB | 55*72*12 TC | SM 曲軸 | 55 | 72 | | 12 | |
| FSG0528NB | 56*72*6.5/11 TB59 | 40232-06R00 | 56 | 72 | | 6.5 | 11 |
| FSG0668NB | 56*72*7 TC | | 56 | 72 | | 7 | |
| FSG0536NB | 56*72*8 TC | | 56 | 72 | | 8 | |
| FSG0638NB | 56*72/77*8/11 Y | 40232-51E10 | 56 | 72 | 77 | 8 | 11 |
| FSG0045NB | 56*72*9 TC | 38189-61500 | 56 | 72 | | 9 | |
| FSG0621NB | 56*72*10 TC | | 56 | 72 | | 10 | |
| FSG0639NB | 56*72*10/14 KB9 | | 56 | 72 | | 10 | 14 |
| FSG0709NB | 56*72*12.5 TCY | | 56 | 72 | | 12.5 | |
| FSG0720NB | 58*72*7 HTBR | | 58 | 72 | | 7 | |
| FSG0264NB | 58*72*7 HTCR | AE3143E, 90311-58006 | 58 | 72 | | 7 | |
| FSG0242FB | 58*72*8 SC(FKM)VITON | | 58 | 72 | | 8 | |
| FSG0213NB | 58*72*8 TC | FB01-26-065A | 58 | 72 | | 8 | |
| FSG0213FB | 58*72*8 TC(VITON) | | 58 | 72 | | 8 | |
| FSG0044NB | 58*72*9 HTCL | TS180 CRANK SHAFT | 58 | 72 | | 9 | |
| FSG0288NB | 58*72*9 TB | | 58 | 72 | | 9 | |
| FSG0156NB | 58*72*9 TC | | 58 | 72 | | 9 | |
| FSG0537NB | 58*72*10 TC | | 58 | 72 | | 10 | |
| FSG0403NB | 59*72*12/12.5 TBG Black | | 59 | 72 | | 12 | 12.5 |
| FSG0161NB | 60*72*7.5 TB | 38212-90006 | 60 | 72 | | 7.5 | |
| FSG0467NB | 60*72*8 TB | | 60 | 72 | | 8 | |
| FSG0661NB | 60*72*8 TC | | 60 | 72 | | 8 | |
| FSG0548NB | 60*72*9 TC | | 60 | 72 | | 9 | |
| FSG0533NB | 60*72*10 TC | | 60 | 72 | | 10 | |
| FSG0580NB | 60*72*12 TB3 | | 60 | 72 | | 12 | |
| FSG0495NB | 60*72*12 TC | | 60 | 72 | | 12 | |
| FSG0369NB | 62*72*9 TC | | 62 | 72 | | 9 | |
| FSG0680NB | 62*72*10 TC | | 62 | 72 | | 10 | |
| FSG0529NB | 45*72.2*7.5/8.5 KC | 91251-692-003/5 | 45 | 72.2 | | 7.5 | 8.5 |
| FSG0656NB | 47*72.2*6/8 KCY | 91251-SA5-003/5 | 47 | 72.2 | | 6 | 8 |
| FSG0552NB | 49*72.2*6/8 Y | 91251-SB0-013/15 | 49 | 72.2 | | 6 | 8 |
| FSG0283NB | 56*72.2*8/10 SC9Y | 09283-56002 | 56 | 72.2 | | 8 | 10 |
| FSG0532NB | 56*72.3*8 TC4(NBR80) | 90625-0020 | 56 | 72.3 | | 8 | |
| FSG0545NB | 56*72.3*8/12 TC9 | 28015-AA021 | 56 | 72.3 | | 8 | 12 |
| FSG0335NB | 35*72.5/75*12.5/15.75/36 Y | Seals 16132023 | 35 | 72.5 | 75 | 12.5 | 15.75 |
| FSG0408NB | 35*72.5/76*12.5/19 Y | 16130014 WLK | 35 | 72.5 | 76 | 12.5 | 19 |
| FSG0411NB | 42*72.5*12 HTBR | 38189-31300/J2000 | 42 | 72.5 | | 12 | |
| FSG0637NB | 48*72.5*10 TC | | 48 | 72.5 | | 10 | |
| FSG0509NB | 48*72.5*12 TC | | 48 | 72.5 | | 12 | |
| FSG0577NB | 50*72.5*12/19.5 TC9 | | 50 | 72.5 | | 12 | 19.5 |
| FSG0043NB | 40*72.6*8/15 TBY | | 40 | 72.6 | | 8 | 15 |
| FSF9989NB | 36.91*72.62/88.49*9.12/15.47 TG59Y | | 36.91 | 72.62 | 88.49 | 9.12 | 15.47 |
| FSG9997NB | 53.85*72.90*6.35 VB | 2.12*2.87*0.25 VB | 53.85 | 72.9 | | 6.35 | |
| FSG0042NB | 42*73*15.5 DC | | 42 | 73 | | 15.5 | |
| FSG0366NB | 43*73*10 TC | | 43 | 73 | | 10 | |
| FSG0632NB | 45*73*8 TC(BROWN) | | 45 | 73 | | 8 | |
| FSG0597NB | 45*73*10 TB | | 45 | 73 | | 10 | |
| FSG0600NB | 46*73*10 TC | | 46 | 73 | | 10 | |
| FSG0113NB | 47*73*10/11.7 TCY | CIR18731SA | 47 | 73 | | 10 | 11.7 |
| FSG0129NB | 47*73*10/12.5 TCY | | 47 | 73 | | 10 | 12.5 |
| FSG0704NB | 47*73*10/12.5 TG | | 47 | 73 | | 10 | 12.5 |
| FSG0041NB | 47*73*10/12.7 HTC | 9415 | 47 | 73 | | 10 | 12.7 |
| FSG0719NB | 47.6*73*9.5/12 TBY | | 47.6 | 73 | | 9.5 | 12 |
| FSG0420NB | 48*73*7 TB | 90311-48013 | 48 | 73 | | 7 | |
| FSG0567NB | 48*73*8 TC | | 48 | 73 | | 8 | |
| FSG0132NB | 50*73*9 TA | 90311-50003 | 50 | 73 | | 9 | |

| WLK CODE | OIL SEALS | DESCRIPTION | ID | OD1 | OD2 | H1 | H2 |
|-----------|----------------------------|--------------------------|--------|--------|------|--------|-------|
| FSG0538NB | 50*73*10 TC | | 50 | 73 | | 10 | |
| FSG0538FB | 50*73*10 TC(VITON) | | 50 | 73 | | 10 | |
| FSG0133NB | 50*73*12 TC | | 50 | 73 | | 12 | |
| FSG0553NB | 51*73*8/12 TB9 | | 51 | 73 | | 8 | 12 |
| FSG0551NB | 52*73*10 TB | | 52 | 73 | | 10 | |
| FSG0736NB | 52*73*10 TC | | 52 | 73 | | 10 | |
| FSG0647NB | 53*73*10 TZ | | 53 | 73 | | 10 | |
| FSG0629NB | 54*73*8 TC | | 54 | 73 | | 8 | |
| FSG0606NB | 54*73*10 TC | | 54 | 73 | | 10 | |
| FSG0468NB | 54*73*10 TZ | | 54 | 73 | | 10 | |
| FSG0375NB | 55*73*6 TB | | 55 | 73 | | 6 | |
| FSG0547NB | 55*73*10 TB | | 55 | 73 | | 10 | |
| FSG0316NB | 55*73*10 TC | | 55 | 73 | | 10 | |
| FSG0252NB | 56*73*8/12.5 TB9Y | 04422-12020, 90311-56008 | 56 | 73 | | 8 | 12.5 |
| FSG0319NB | 56*73*10 TC | | 56 | 73 | | 10 | |
| FSF0522NB | 56*73/77.7*14 TB59Y | 90311-56006 | 56 | 73 | 77.7 | 14 | |
| FSG0272NB | 57*73*7 OSC | 26134-6401P | 57 | 73 | | 7 | |
| FSG0368NB | 57*73*7 TC | | 57 | 73 | | 7 | |
| FSG0611NB | 60*73*10 TC | | 60 | 73 | | 10 | |
| FSG0483NB | 60*73*11/7 HTBC | | 60 | 73 | | 11 | 7 |
| FSG0105NB | 41.25*73.02*10 TB | 1.624*2.875*0.394 TB | 41.25 | 73.02 | | 10 | |
| FSG9909NB | 41.27*73.02*7.93 SC | | 41.27 | 73.02 | | 7.93 | |
| FSG9858NB | 41.28*73.02*9.53 TC | | 41.28 | 73.02 | | 9.53 | |
| FSG9875NB | 44.45*73.02*9.53 TC | | 44.45 | 73.02 | | 9.53 | |
| FSG9875FB | 44.45*73.02*9.53 TC(VITON) | VITON | 44.45 | 73.02 | | 9.53 | |
| FSG9864NB | 44.45*73.02*12.7 TC | | 44.45 | 73.02 | | 12.7 | |
| FSG9982NB | 47.63*73.02*7.95 TB | | 47.63 | 73.02 | | 7.95 | |
| FSG9901NB | 47.63*73.02*9.53 TC | 1.875*2.875*0.375 | 47.63 | 73.02 | | 9.53 | |
| FSG9901FB | 47.63*73.02*9.53 TC(FKM) | 1.875*2.875*0.375(VITON) | 47.63 | 73.02 | | 9.53 | |
| FSG9899NB | 47.63*73.02*11.91 TC | | 47.63 | 73.02 | | 11.91 | |
| FSG9865NB | 50.8*73.02*9.52 SC | | 50.8 | 73.02 | | 9.52 | |
| FSG9979NB | 50.8*73.02*9.52 TC | 2.000*2.875*0.375 | 50.8 | 73.02 | | 9.52 | |
| FSG9856NB | 50.8*73.02*12.7 TC | | 50.8 | 73.02 | | 12.7 | |
| FSG9877NB | 52.38*73.02*9.52 TC | | 52.38 | 73.02 | | 9.52 | |
| FSG9962N0 | 53.19*73.02*5.94 VM(NBR80) | | 53.19 | 73.02 | | 5.94 | |
| FSG9981NB | 53.97*73.02*11.13 SA | | 53.97 | 73.02 | | 11.13 | |
| FSG0332NB | 53.97*73.02*11.13 TA | | 53.97 | 73.02 | | 11.13 | |
| FSG9855NB | 53.97*73.02*11.13 TB | | 53.97 | 73.02 | | 11.13 | |
| FSG9880NB | 53.97*73.02*11.91 TA | | 53.97 | 73.02 | | 11.91 | |
| FSG9887N0 | 53.98*73.02*6.35 VB | | 53.98 | 73.02 | | 6.35 | |
| FSG9882NB | 53.98*73.02*9.53 TC | | 53.98 | 73.02 | | 9.53 | |
| FSH9953NB | 55.58*73.02*12.7 SC | | 55.58 | 73.02 | | 12.7 | |
| FSG9894NB | 57.15*73.02*9.52 TC | | 57.15 | 73.02 | | 9.52 | |
| FSG0341NB | 41.681*73.025*15.875 DC | 1.641*2.875*0.625 DC | 41.681 | 73.025 | | 15.875 | |
| FSG0306NB | 44.45*73.03*9.53 TC | 1.750*2.875*0.375 TC | 44.45 | 73.03 | | 9.53 | |
| FSG9974NB | 44.45*73.03*11.90 TC | 1.750*2.875*0.469 TC | 44.45 | 73.03 | | 11.9 | |
| FSG0257NB | 53.19*73.03*12.7 SB | 2.094*2.875*0.500 SB | 53.19 | 73.03 | | 12.7 | |
| FSG9999FB | 53.98*73.03*9.53 TB(FKM) | | 53.98 | 73.03 | | 9.53 | |
| FSG9980NB | 53.98*73.03*9.53 TC | 2.125*2.875*0.375 | 53.98 | 73.03 | | 9.53 | |
| FSG9980FB | 53.98*73.03*9.53 TC(FKM) | 2.125*2.875*0.375 TC | 53.98 | 73.03 | | 9.53 | |
| FSG0120NB | 53.98*73.03*11.13 SB | 2.125*2.875*0.438 SB | 53.98 | 73.03 | | 11.13 | |
| FSG0139NB | 53.98*73.03*12.7 SB | 2.125*2.875*0.500 SB | 53.98 | 73.03 | | 12.7 | |
| FSG9861NB | 53.98*73.03*12.7 TA | | 53.98 | 73.03 | | 12.7 | |
| FSG9986NB | 53.98*73.03*12.7 TC | 2.125*2.875*0.500 TC | 53.98 | 73.03 | | 12.7 | |
| FSG9995NB | 47.63*73.08*9.93/12.45 | 1.875*2.877*0.391/0.49HT | 47.63 | 73.08 | | 9.93 | 12.45 |
| FSG0116NB | 47.6*73.1*9.5 TC | | 47.6 | 73.1 | | 9.5 | |
| FSG0135NB | 53.98*73.13*11.13 SB | 2.125*2.879*0.438 SB | 53.98 | 73.13 | | 11.13 | |

| WLK CODE | OIL SEALS | DESCRIPTION | ID | OD1 | OD2 | H1 | H2 |
|-----------|---------------------------|--------------------------|------|------|------|------|------|
| FSG0590NB | 35*74*10 TC | | 35 | 74 | | 10 | |
| FSG0076NB | 35*74/81*11/15 TC4Y | 113BA00 | 35 | 74 | 81 | 11 | 15 |
| FSG0660NB | 38*74*10 TC | | 38 | 74 | | 10 | |
| FSG0040NB | 38*74*11 HTBR | 90311-38133, 90311-38010 | 38 | 74 | | 11 | |
| FSG0091NB | 38*74*11 TB | 90311-38133/4/028 | 38 | 74 | | 11 | |
| FSG0624NB | 38*74*11 TC | | 38 | 74 | | 11 | |
| FSG0630NB | 38*74*11/18 HTC9R | 90311-38070 | 38 | 74 | | 11 | 18 |
| FSG0703NB | 38*74*11/18 TB9 | | 38 | 74 | | 11 | 18 |
| FSG0262NB | 38*74*11/18 TB9(UDS9) | 90311-38035 | 38 | 74 | | 11 | 18 |
| FSG0365NB | 38*74*11.5 HTBR | NJ-002 | 38 | 74 | | 11.5 | |
| FSG0562NB | 40*74*9.5/18.5 HTB29L | | 40 | 74 | | 9.5 | 18.5 |
| FSG0293NB | 40*74*10 TC | | 40 | 74 | | 10 | |
| FSG0100NB | 40*74*10/18.5 TB9(UEB) | 9-09724-003-0 | 40 | 74 | | 10 | 18.5 |
| FSG0270NB | 40*74/80*14.5 TC4Y | 113BA02 | 40 | 74 | 80 | 14.5 | |
| FSG0507NB | 41*74*11/18 HTC9 | 90311-41009 | 41 | 74 | | 11 | 18 |
| FSG0106NB | 44*74*11/17 TB9 | 90311-44005 | 44 | 74 | | 11 | 17 |
| FSG0598NB | 45*74*12 TB | | 45 | 74 | | 12 | |
| FSG0124NB | 48*74*9 TC | | 48 | 74 | | 9 | |
| FSG0230NB | 48*74*10 TC | 90311-48002 | 48 | 74 | | 10 | |
| FSG0243NB | 48*74*10/15 TC9 | 90311-48009 | 48 | 74 | | 10 | 15 |
| FSG0665NB | 50*74*9 SC | | 50 | 74 | | 9 | |
| FSG0445NB | 50*74*10 TC | | 50 | 74 | | 10 | |
| FSG0381NB | 50*74*11 HTC3R | ME-202850 | 50 | 74 | | 11 | |
| FSG0381FB | 50*74*11 HTC3R(FKM)VITON | ME-202850 | 50 | 74 | | 11 | |
| FSG0381QB | 50*74*11 HTC3R(VMQ) | BH5679E | 50 | 74 | | 11 | |
| FSG0716NB | 50*74*12 TC | | 50 | 74 | | 12 | |
| FSE0569N0 | 52*74*11/19 Y W/Felt | ME200753 ;BZ5001E | 52 | 74 | | 11 | 19 |
| FSG0525NB | 54*74*8 TB | | 54 | 74 | | 8 | |
| FSG0744NB | 54*74*10 SB | | 54 | 74 | | 10 | |
| FSG0157NB | 58*74*10 HTCL | 90043-11222 | 58 | 74 | | 10 | |
| FSG0158NB | 58*74*10 TC | | 58 | 74 | | 10 | |
| FSG0336NB | 60*74*7.5 TM3 | 9828-60108 | 60 | 74 | | 7.5 | |
| FSG0747NB | 60*74*10 SC | | 60 | 74 | | 10 | |
| FSG0751FB | 60*74*10 TB(VITON) | | 60 | 74 | | 10 | |
| FSG0613NB | 60*74*10 TC | | 60 | 74 | | 10 | |
| FSG0374NB | 62*74*8 TB3 | 90311-62003 | 62 | 74 | | 8 | |
| FSG0167NB | 62*74*8 TC | | 62 | 74 | | 8 | |
| FSG0289NB | 56*74.1/78*7.5/10.7 TB59 | | 56 | 74.1 | 78 | 7.5 | 10.7 |
| FSG0250NB | 56*74.2/78*7.5/10.7 TB59 | 40227-0M000, N2265 | 56 | 74.2 | 78 | 7.5 | 10.7 |
| FSG0109NB | 45*74.5/79.5*12/14.5 HTC5 | 011 997 22 47A | 45 | 74.5 | 79.5 | 12 | 14.5 |
| FSG0039NB | 30*75*8 TC | | 30 | 75 | | 8 | |
| FSG0038NB | 30*75*9 TC | G65 | 30 | 75 | | 9 | |
| FSG0498NB | 34*75*10 TC | | 34 | 75 | | 10 | |
| FSG0431NB | 34.5*75/76*11/12 TCY | WHIRLPOOL481253058142 | 34.5 | 75 | 76 | 11 | 12 |
| FSG0253NB | 35*75*8 TC | | 35 | 75 | | 8 | |
| FSG0686NB | 35*75*10 TC | | 35 | 75 | | 10 | |
| FSG0593NB | 38*75*10 TC | | 38 | 75 | | 10 | |
| FSG0595NB | 40*75*8 TC | | 40 | 75 | | 8 | |
| FSG0595FB | 40*75*8 TC(VITON) | | 40 | 75 | | 8 | |
| FSG0247NB | 40*75*10 TC | | 40 | 75 | | 10 | |
| FSG0247FB | 40*75*10 TC(VITON) | | 40 | 75 | | 10 | |
| FSG0351NB | 40*75*11/16.5 TB5Y | P017-27-165;BD3063E | 40 | 75 | | 11 | 16.5 |
| FSG0741NB | 40*75/89*11/15.5 TB5Y | | 40 | 75 | 89 | 11 | 15.5 |
| FSG0244NB | 40*75*12 TC | 0604-27-018 | 40 | 75 | | 12 | |
| FSG0244NS | 40*75*12 TC(S304 SPRING) | SUS304 SPRING | 40 | 75 | | 12 | |
| FSG0409NB | 40*75*12/17 HTC9R | 是 40*75*12/17.5 UE..LR | 40 | 75 | | 12 | 17 |
| FSG0101NB | 40*75*12/17.5 UE..LR | 38189-N3100 (HTC9R) | 40 | 75 | | 12 | 17.5 |

| WLK CODE | OIL SEALS | DESCRIPTION | ID | OD1 | OD2 | H1 | H2 |
|-----------|-----------------------------|--------------------|----|-----|-----|------|------|
| FSG0663NB | 40*75*12/19 HTC9L | 38189-21G00;15882 | 40 | 75 | | 12 | 19 |
| FSG0418NB | 40*75/81*14/21 HTB59R | | 40 | 75 | 81 | 14 | 21 |
| FSG0437NB | 42*75*9 TC | | 42 | 75 | | 9 | |
| FSG0541NB | 42*75*10 TC | | 42 | 75 | | 10 | |
| FSG0570AB | 42*75*11.5/9.5 HTBC5RY(ACM) | | 42 | 75 | | 11.5 | 9.5 |
| FSG0486NB | 42*75*12 TC | | 42 | 75 | | 12 | |
| FSG0499NB | 43*75*10 TC | | 43 | 75 | | 10 | |
| FSG0511NB | 45*75*7 TC | | 45 | 75 | | 7 | |
| FSG0354NB | 45*75*8 SC | | 45 | 75 | | 8 | |
| FSG0077NB | 45*75*8 TC | | 45 | 75 | | 8 | |
| FSG0077FB | 45*75*8 TC(FKM)VITON | | 45 | 75 | | 8 | |
| FSG0707FB | 45*75*10 SC(VITON) | | 45 | 75 | | 10 | |
| FSG0229NB | 45*75*10 TC | 113AE01 | 45 | 75 | | 10 | |
| FSG0229NS | 45*75*10 TC(S304 SPRING) | | 45 | 75 | | 10 | |
| FSG0111NB | 45*75*12 TB2 | | 45 | 75 | | 12 | |
| FSG0037NB | 45*75*12 TC | 38189-61000 | 45 | 75 | | 12 | |
| FSG0037FB | 45*75*12 TC(VITON) | | 45 | 75 | | 12 | |
| FSG0491NB | 48*75*7.5/17.5 | BG4415E | 48 | 75 | | 7.5 | 17.5 |
| FSG0125FB | 48*75*8 HSBR (FKM) | | 48 | 75 | | 8 | |
| FSG0125NB | 48*75*8 HSBR(NBR) | | 48 | 75 | | 8 | |
| FSG0465NB | 48*75*8 TB | | 48 | 75 | | 8 | |
| FSG0232NB | 48*75*8 TC | | 48 | 75 | | 8 | |
| FSG0650NB | 48*75*10 TC | | 48 | 75 | | 10 | |
| FSG0735NB | 48*75*12 TC | | 48 | 75 | | 12 | |
| FSG0618NB | 50*75*6 TC | | 50 | 75 | | 6 | |
| FSG0695NB | 50*75*8 SB | | 50 | 75 | | 8 | |
| FSG0370NB | 50*75*8 TC | | 50 | 75 | | 8 | |
| FSG0370FB | 50*75*8 TC (FKM)VITON | | 50 | 75 | | 8 | |
| FSG0622NB | 50*75*9 TB | | 50 | 75 | | 9 | |
| FSG0404NB | 50*75*9 TC | | 50 | 75 | | 9 | |
| FSG0235NB | 50*75*10 TC | | 50 | 75 | | 10 | |
| FSG0235FB | 50*75*10 TC(VITON) | | 50 | 75 | | 10 | |
| FSG0036NB | 50*75*12 TC | | 50 | 75 | | 12 | |
| FSG0084NB | 50*75*12/17 TBY | W001-27-165 | 50 | 75 | | 12 | 17 |
| FSG0382NB | 50*75*13 TBY | | 50 | 75 | | 13 | |
| FSG0284NB | 52*75*7.5/12 TB9 | 90311-52005 | 52 | 75 | | 7.5 | 12 |
| FSG0202NB | 52*75*10 TC | | 52 | 75 | | 10 | |
| FSG0202FB | 52*75*10 TC(VITON) | | 52 | 75 | | 10 | |
| FSG0137NB | 52*75*12 HTCL | NM155/180 曲軸 | 52 | 75 | | 12 | |
| FSG0137QB | 52*75*12 HTCL(VMQ) | | 52 | 75 | | 12 | |
| FSG0035NB | 52*75*12 TC | | 52 | 75 | | 12 | |
| FSG0034NB | 52*75*13 TBY | NT75/F6 曲軸 | 52 | 75 | | 13 | |
| FSG0523NB | 52*75*14/20.5 DCY | AW2969E | 52 | 75 | | 14 | 20.5 |
| FSG0603NB | 53*75*12 TC | | 53 | 75 | | 12 | |
| FSG0608NB | 54*75*8 TC | | 54 | 75 | | 8 | |
| FSG0513NB | 54*75*8/11.5 TB9 | | 54 | 75 | | 8 | 11.5 |
| FSG0443NB | 55*75*7 TCV NBR Blue80 | | 55 | 75 | | 7 | |
| FSG0147FB | 55*75*8 HSBR (FKM)VITON | | 55 | 75 | | 8 | |
| FSG0147NB | 55*75*8 HSBR(NBR)BROWN | 6013(NBR BROWN) | 55 | 75 | | 8 | |
| FSG0378NB | 55*75*8 TC | | 55 | 75 | | 8 | |
| FSG0378FB | 55*75*8 TC(FKM)VITON | | 55 | 75 | | 8 | |
| FSG0251NB | 55*75*8/12 TB9Y | 正確是 56*75*8/12 TB9 | 55 | 75 | | 8 | 12 |
| FSG0572NB | 55*75*9 TB | | 55 | 75 | | 9 | |
| FSG0241NB | 55*75*9 TC | | 55 | 75 | | 9 | |
| FSG0616NB | 55*75*10 SB | | 55 | 75 | | 10 | |
| FSG0658FB | 55*75*10 SC(VITON) | | 55 | 75 | | 10 | |
| FSG0148NB | 55*75*10 TB | | 55 | 75 | | 10 | |

| WLK CODE | OIL SEALS | DESCRIPTION | ID | OD1 | OD2 | H1 | H2 |
|-----------|---------------------------|------------------------|----|-----|-----|-----|------|
| FSG0149NB | 55*75*10 TC | | 55 | 75 | | 10 | |
| FSG0149NS | 55*75*10 TC(S304 SPRING) | | 55 | 75 | | 10 | |
| FSG0149FB | 55*75*10 TC(VITON) | | 55 | 75 | | 10 | |
| FSG0518NB | 55*75*12 DC(BROWN) | AW2967E, | 55 | 75 | | 12 | |
| FSG0534FB | 55*75*12 SC(FKM)VITON | | 55 | 75 | | 12 | |
| FSG0556NB | 55*75*12 TB | | 55 | 75 | | 12 | |
| FSG0082NB | 55*75*12 TC | | 55 | 75 | | 12 | |
| FSG0082FB | 55*75*12 TC(VITON) | | 55 | 75 | | 12 | |
| FSG0388NB | 55*75*12 TCN | UP0803E | 55 | 75 | | 12 | |
| FSG0285NB | 56*75*6.5/11 TB9 | 90311-56007 | 56 | 75 | | 6.5 | 11 |
| FSG0612NB | 56*75*8 TB | | 56 | 75 | | 8 | |
| FSG0679NB | 56*75*8 TC | | 56 | 75 | | 8 | |
| FSG0322NB | 56*75*8/12 TB9 | 04422-20010 (T1168) | 56 | 75 | | 8 | 12 |
| FSG0033NB | 56*75*9 TC | | 56 | 75 | | 9 | |
| FSG0275NB | 57*75*7.5/11 TC9Y W/NYLON | 實際尺寸 58*75*7.5/11.5 | 57 | 75 | | 7.5 | 11 |
| FSG0446NB | 57*75*7.5/11.5 TC9 | | 57 | 75 | | 7.5 | 11.5 |
| FSG0192NB | 57*75*9 TC | | 57 | 75 | | 9 | |
| FSG0032NB | 57*75*12 TC | | 57 | 75 | | 12 | |
| FSG0496NB | 58*75*7.5/11.5 Y(TBY) | 是WLK 57*75*7.5/11 TC9Y | 58 | 75 | | 7.5 | 11.5 |
| FSG0670NB | 58*75*8 TC | | 58 | 75 | | 8 | |
| FSG0031NB | 58*75*9 HTCL | TS155/155C/180C/190 曲軸 | 58 | 75 | | 9 | |
| FSG0031AB | 58*75*9 HTCL (ACM) | | 58 | 75 | | 9 | |
| FSG0287NB | 58*75*9 TB | MB-092712 | 58 | 75 | | 9 | |
| FSG0159NB | 58*75*9 TC | 32136-Z5000 | 58 | 75 | | 9 | |
| FSG0263NB | 58*75*9/14.5 HTC9R | AH-3148P , 90311-58005 | 58 | 75 | | 9 | 14.5 |
| FSG0214NB | 58*75*10 TC | | 58 | 75 | | 10 | |
| FSG0485NB | 58*75*12 TC | | 58 | 75 | | 12 | |
| FSG0485QB | 58*75*12 TC(VMQ) | | 58 | 75 | | 12 | |
| FSG0708NB | 59*75*9/11.5 TB9 | | 59 | 75 | | 9 | 11.5 |
| FSG0295NB | 59*75*10 TB | 8-94407-711-0/9 | 59 | 75 | | 10 | |
| FSG0030NB | 60*75*6 SC | | 60 | 75 | | 6 | |
| FSG0563QB | 60*75*8 HTCL(VMQ) | | 60 | 75 | | 8 | |
| FSG0666NB | 60*75*8 SB | | 60 | 75 | | 8 | |
| FSG0029NB | 60*75*8 SC | | 60 | 75 | | 8 | |
| FSG0029FU | 60*75*8 SC(FKM)S316 | (FKM) SUS316 SPRING | 60 | 75 | | 8 | |
| FSG0296NB | 60*75*8 TB | | 60 | 75 | | 8 | |
| FSG0193NB | 60*75*8 TC | | 60 | 75 | | 8 | |
| FSG0193FB | 60*75*8 TC(VITON) | | 60 | 75 | | 8 | |
| FSG0193QB | 60*75*8 TC(VMQ) | | 60 | 75 | | 8 | |
| FSG0732FB | 60*75*8/9 TCV(VITON) | | 60 | 75 | | 8 | 9 |
| FSG0398NB | 60*75*9 TB | | 60 | 75 | | 9 | |
| FSG0028NB | 60*75*9 TC | | 60 | 75 | | 9 | |
| FSG0407NB | 60*75*9/15 HTB9L | 9828-60119;BH0400E | 60 | 75 | | 9 | 15 |
| FSG0162NB | 60*75*9/15 TC9 | | 60 | 75 | | 9 | 15 |
| FSG0569NB | 60*75*9/9.5 TCV(NBR80) | | 60 | 75 | | 9 | 9.5 |
| FSG0355NB | 60*75*10 SC | | 60 | 75 | | 10 | |
| FSG0219NB | 60*75*10 TC | | 60 | 75 | | 10 | |
| FSG0219FB | 60*75*10 TC(VITON) | | 60 | 75 | | 10 | |
| FSG0379NB | 60*75*12 TC | | 60 | 75 | | 12 | |
| FSG0379FB | 60*75*12 TC(VITON) | | 60 | 75 | | 12 | |
| FSG0401NB | 62*75*7.5/8 TCV | | 62 | 75 | | 7.5 | 8 |
| FSF0622NB | 62*75*8 SB | | 62 | 75 | | 8 | |
| FSG0481NB | 62*75*10 TB | | 62 | 75 | | 10 | |
| FSG0614NB | 62*75*10 TC | | 62 | 75 | | 10 | |
| FSG0685N0 | 63*75*5 VB | | 63 | 75 | | 5 | |
| FSG0539NB | 64*75*10 TC | | 64 | 75 | | 10 | |
| FSG0356NB | 65*75*7 SC | | 65 | 75 | | 7 | |

| WLK CODE | OIL SEALS | DESCRIPTION | ID | OD1 | OD2 | H1 | H2 |
|-----------|-----------------------------------|------------------------|-------|-------|-----|-------|------|
| FSG0356QB | 65*75*7 SC(VMQ) | | 65 | 75 | | 7 | |
| FSG0353NB | 65*75*8 TC | | 65 | 75 | | 8 | |
| FSG9975NB | 41.28*75.01*11.51 HTB5Y | | 41.28 | 75.01 | | 11.51 | |
| FSG0254NB | 54*75.5*12/18 TC59Y W/NYLON COVER | 40232-01G00 | 54 | 75.5 | | 12 | 18 |
| FSG0591NB | 35*76*9 TC | | 35 | 76 | | 9 | |
| FSG0455NB | 35*76*9/12.5 HTC9R | 91206-689-003/05,NJ777 | 35 | 76 | | 9 | 12.5 |
| FSG0089NB | 35*76*10/14 TC4 | Miele, Universal | 35 | 76 | | 10 | 14 |
| FSG0643NB | 37*76*9.5/13.5 TGU9Y | 37*76*9.5/12 | 37 | 76 | | 9.5 | 13.5 |
| FSG0402NB | 40*76*8 TC | | 40 | 76 | | 8 | |
| FSG0559NB | 40*76*8/11 HTC9R | 應是我司40*76*9/12.5 HTC | 40 | 76 | | 8 | 11 |
| FSG0641AB | 40*76*8/12 HTC9RY(ACM) | | 40 | 76 | | 8 | 12 |
| FSG0641NB | 40*76*8/12 HTC9RY | | 40 | 76 | | 8 | 12 |
| FSG0678NB | 40*76*9 TC | | 40 | 76 | | 9 | |
| FSG0360NB | 40*76*9/12.5 HTC9R | BH1952E | 40 | 76 | | 9 | 12.5 |
| FSG0746NB | 42*76*10 TC | | 42 | 76 | | 10 | |
| FSG0310NB | 42*76*12 TC | | 42 | 76 | | 12 | |
| FSG0325NB | 42*76*12/21 TC39 | 38189-C7000 | 42 | 76 | | 12 | 21 |
| FSG0583NB | 42*76/83*13.5/21.3 HTB59R | | 42 | 76 | 83 | 13.5 | 21.3 |
| FSG0453NB | 45*76*10 TC | | 45 | 76 | | 10 | |
| FSG0745NB | 45*76*12 TC | | 45 | 76 | | 12 | |
| FSG0313NB | 50*76*10 TC | | 50 | 76 | | 10 | |
| FSG0134NB | 50*76*12 TC | | 50 | 76 | | 12 | |
| FSG0711NB | 51*76*9.5 SC | | 51 | 76 | | 9.5 | |
| FSG0730NB | 51*76*9.5/14.5 TCY | | 51 | 76 | | 9.5 | 14.5 |
| FSG0602NB | 52*76*10 SB | | 52 | 76 | | 10 | |
| FSG0371NB | 52*76*10 TC | | 52 | 76 | | 10 | |
| FSG0689NB | 52*76*11/12 TB2Y | 8-97216-792-0 | 52 | 76 | | 11 | 12 |
| FSG0604NB | 53*76*10 TC | | 53 | 76 | | 10 | |
| FSG0027NB | 54*76*8 HTCL | ER100曲軸 | 54 | 76 | | 8 | |
| FSG0588FB | 54*76*8 TC(VITON)FKM | | 54 | 76 | | 8 | |
| FSG0280NB | 54*76*8/11 TB9 | MB-808443 NBR313材質 | 54 | 76 | | 8 | 11 |
| FSG0627NB | 54*76*13 TC | | 54 | 76 | | 13 | |
| FSG0566NB | 55*76*8 TC | | 55 | 76 | | 8 | |
| FSG0300NB | 55*76*10 TC | | 55 | 76 | | 10 | |
| FSG0318NB | 55*76*12 TC | | 55 | 76 | | 12 | |
| FSG0249NB | 56*76*6/12 TB59(Paint) | MB-160850 | 56 | 76 | | 6 | 12 |
| FSG0633NB | 56*76/80*6.3/12.3 TB59Y | | 56 | 76 | 80 | 6.3 | 12.3 |
| FSG0448NB | 56*76*10 TC | | 56 | 76 | | 10 | |
| FSG0449NB | 56*76*12 TC | | 56 | 76 | | 12 | |
| FSG0472NB | 57*76*6.8/9.5 TB9 | 是57*76*7/10 TB9 | 57 | 76 | | 6.8 | 9.5 |
| FSG0384NB | 57*76*7/10 TB9 | MB-633434 | 57 | 76 | | 7 | 10 |
| FSG0025NB | 57*76*13 TB | | 57 | 76 | | 13 | |
| FSG0444NB | 58*76*7.8/16 TC9 | 90625-0018 | 58 | 76 | | 7.8 | 16 |
| FSG0329NB | 58*76*8/16 TC9Y | 90625-0018 | 58 | 76 | | 8 | 16 |
| FSG0451NB | 58*76*9 SC(BROWN) | | 58 | 76 | | 9 | |
| FSG0450NB | 59*76*9 TB/TBP | | 59 | 76 | | 9 | |
| FSG0452NB | 59*76*9 TC | | 59 | 76 | | 9 | |
| FSG0345NB | 60*76*7 HTCL | BH5434E | 60 | 76 | | 7 | |
| FSG0348NB | 60*76*8 TC | | 60 | 76 | | 8 | |
| FSG0410NB | 60*76*9 TC | | 60 | 76 | | 9 | |
| FSG0558NB | 60*76*9/15 SZ9Y | Green Painting | 60 | 76 | | 9 | 15 |
| FSG0475NB | 61*76*7/10 TB9 | 90311-61001 | 61 | 76 | | 7 | 10 |
| FSG0347NB | 62*76*9 TB | 9828-62103 AD3286 | 62 | 76 | | 9 | |
| FSG9906NB | 38.1*76.2*9.53 SC | | 38.1 | 76.2 | | 9.53 | |
| FSG9905NB | 38.1*76.2*9.53 TC | | 38.1 | 76.2 | | 9.53 | |
| FSG9904NB | 41.28*76.2*6.35 TC | | 41.28 | 76.2 | | 6.35 | |

| WLK CODE | OIL SEALS | DESCRIPTION | ID | OD1 | OD2 | H1 | H2 |
|-----------|---------------------------------|--------------------------|--------|-------|-----|--------|------|
| FSG9895NB | 44.45*76.2*9.53 TC | | 44.45 | 76.2 | | 9.53 | |
| FSG9907NB | 44.45*76.2*12.7 SC | | 44.45 | 76.2 | | 12.7 | |
| FSG9959NB | 47.63*76.2*7.95 SB | | 47.63 | 76.2 | | 7.95 | |
| FSG9988NB | 47.63*76.2*7.95 SC | | 47.63 | 76.2 | | 7.95 | |
| FSG9885NB | 47.63*76.2*9.53 SC | | 47.63 | 76.2 | | 9.53 | |
| FSG9869NB | 47.63*76.2*11.13 TC | 1.875*3.000*0.438 TC | 47.63 | 76.2 | | 11.13 | |
| FSG9910NB | 47.63*76.2*12.7 SA | | 47.63 | 76.2 | | 12.7 | |
| FSG0118NB | 47.63*76.2*12.7 TC | 1.875*3.000*0.500 TC | 47.63 | 76.2 | | 12.7 | |
| FSG9962NB | 49.23*76.2*7.95 TB | | 49.23 | 76.2 | | 7.95 | |
| FSG0364NB | 49.23*76.2*8.07 TB Red Painting | 1.938*3.000*0.318 TB紅漆 | 49.23 | 76.2 | | 8.07 | |
| FSG9892NB | 49.23*76.2*9.53 TC | | 49.23 | 76.2 | | 9.53 | |
| FSG9987NB | 50.8*76.2*6.35 SB | | 50.8 | 76.2 | | 6.35 | |
| FSG9867NB | 50.8*76.2*6.35 TC | | 50.8 | 76.2 | | 6.35 | |
| FSG9898NB | 50.8*76.2*7.95 TB | | 50.8 | 76.2 | | 7.95 | |
| FSG9977NB | 50.8*76.2*9.53 SB | | 50.8 | 76.2 | | 9.53 | |
| FSG9973NB | 50.8*76.2*9.53 TC | 2.000*3.000*0.375 | 50.8 | 76.2 | | 9.53 | |
| FSG9973FB | 50.8*76.2*9.53 TC(VITON) | 2.000*3.000*0.375(VITON) | 50.8 | 76.2 | | 9.53 | |
| FSG9963NB | 50.8*76.2*12.7 SB(SM) | | 50.8 | 76.2 | | 12.7 | |
| FSG0024NB | 50.8*76.2*12.7 SC | 2.000*3.000*0.500 SC | 50.8 | 76.2 | | 12.7 | |
| FSG0271NB | 50.8*76.2*12.7 TC | 2.000*3.000*0.500 TC | 50.8 | 76.2 | | 12.7 | |
| FSG0023NB | 52.4*76.2*9/15 TBY | | 52.4 | 76.2 | | 9 | 15 |
| FSG9971NB | 52.4*76.2*9.53 TC | 2.063*3.000*0.375 TC | 52.4 | 76.2 | | 9.53 | |
| FSG9978NB | 53.97*76.2*9.53 TB | | 53.97 | 76.2 | | 9.53 | |
| FSG9900NB | 53.97*76.2*12.7 TC | | 53.97 | 76.2 | | 12.7 | |
| FSG9879NB | 53.97*76.2*12.7 TZ | | 53.97 | 76.2 | | 12.7 | |
| FSG0350N0 | 53.98*76.2*7.95 KM | 2.125*3.000*0.313 KM | 53.98 | 76.2 | | 7.95 | |
| FSG9903NB | 53.98*76.2*9.5/15.5 TC9W | | 53.98 | 76.2 | | 9.5 | 15.5 |
| FSG9878NB | 53.98*76.2*12.7 TC | | 53.98 | 76.2 | | 12.7 | |
| FSG9985NB | 55.56*76.2*9.52 SC | | 55.56 | 76.2 | | 9.52 | |
| FSG9970NB | 55.58*76.2*9.53 TC | | 55.58 | 76.2 | | 9.53 | |
| FSG0675NB | 55.58*76.2*11.13 TB | | 55.58 | 76.2 | | 11.13 | |
| FSG9969NB | 57.15*76.2*9.5 TB | | 57.15 | 76.2 | | 9.5 | |
| FSG9886NB | 57.15*76.2*9.53 SB | | 57.15 | 76.2 | | 9.53 | |
| FSG9986FB | 57.15*76.2*9.53 SB VITON | | 57.15 | 76.2 | | 9.53 | |
| FSG9854NB | 57.15*76.2*9.53 TB | | 57.15 | 76.2 | | 9.53 | |
| FSG0022NB | 57.15*76.2*9.53 TC | 2.250*3.000*0.375 TC | 57.15 | 76.2 | | 9.53 | |
| FSG9983NB | 57.15*76.2*12.7 TA | | 57.15 | 76.2 | | 12.7 | |
| FSG9859NB | 57.15*76.2*12.7 TB | | 57.15 | 76.2 | | 12.7 | |
| FSG9990NB | 57.15*76.2*12.7 TC | 2.250*3.000*0.500 TC | 57.15 | 76.2 | | 12.7 | |
| FSG0164QB | 60.3*76.2*11 SC (VMQ) | | 60.3 | 76.2 | | 11 | |
| FSG9998NB | 60.325*76.2*11.125 HTCL | 2.375*3.000*0.438 HTCL | 60.325 | 76.2 | | 11.125 | |
| FSG9902NB | 60.33*76.2*9.53 SB | | 60.33 | 76.2 | | 9.53 | |
| FSG9976NB | 60.33*76.2*9.53 TC | | 60.33 | 76.2 | | 9.53 | |
| FSG9994N0 | 61.47*76.2*7.14/9.93 KB9 | 2.42*3.0*0.281/0.391 KB9 | 61.47 | 76.2 | | 7.14 | 9.93 |
| FSG9893NB | 63.5*76.2*6.35 TC | | 63.5 | 76.2 | | 6.35 | |
| FSG0657NB | 63.5*76.2*12.7 TC | | 63.5 | 76.2 | | 12.7 | |
| FSG0198NB | 50.8*76.23*12.7 TC | | 50.8 | 76.23 | | 12.7 | |
| FSG0246NB | 57*76.23*9.5 SC | | 57 | 76.23 | | 9.5 | |
| FSG0150NB | 55*76.25*13 LS | | 55 | 76.25 | | 13 | |
| FSG0259NB | 57.15*76.27*12.7/7.9 HTCR | Blue | 57.15 | 76.27 | | 12.7 | 7.9 |
| FSG0154N0 | 55*76.3*7.7 KB(KM) | | 55 | 76.3 | | 7.7 | |
| FSG0197NB | 57*76.45*9.5 SC | | 57 | 76.45 | | 9.5 | |
| FSG0440NB | 39*76.5*10.5/14 SCY | | 39 | 76.5 | | 10.5 | 14 |
| FSG0026NB | 30*77*9 TC | G65 | 30 | 77 | | 9 | |
| FSG0141N0 | 51.5*77*11 軟 | | 51.5 | 77 | | 11 | |
| FSG0372NB | 55*77*8.5 HTCR | | 55 | 77 | | 8.5 | |
| FSG0155QB | 57*77*10 HTCL(VMQ) | | 57 | 77 | | 10 | |

| WLK CODE | OIL SEALS | DESCRIPTION | ID | OD1 | OD2 | H1 | H2 |
|-----------|--------------------------|--------------------------|--------|------|------|------|------|
| FSG0163NB | 60*77*10 HTCL | 8067-60010 (S4890) | 60 | 77 | | 10 | |
| FSG0286NB | 60*77*12 TB | 1-09625-173-0 | 60 | 77 | | 12 | |
| FSG0405NB | 60*77*12 TC | | 60 | 77 | | 12 | |
| FSG0385NB | 60*77/92*16 DB5Y(Paint) | 外徑以77軸徑為主 | 60 | 77 | 92 | 16 | |
| FSG0655NB | 62*77*9 HTCR | | 62 | 77 | | 9 | |
| FSG0561NB | 64*77*12 HT3BLR | | 64 | 77 | | 12 | |
| FSG0705NB | 65*77*8.5 SC | | 65 | 77 | | 8.5 | |
| FSG0699NB | 65*77*9 TC | | 65 | 77 | | 9 | |
| FSG0338NB | 65*77*12 TM | MH-034135 | 65 | 77 | | 12 | |
| FSG9966NB | 50.8*77.8*9.53 TB | | 50.8 | 77.8 | | 9.53 | |
| FSG9896NB | 53.97*77.8*12.7 TA | | 53.97 | 77.8 | | 12.7 | |
| FSG9991NB | 53.975*77.80*12.7 TC | 2.125*3.063*0.500 TC | 53.975 | 77.8 | | 12.7 | |
| FSG9888NB | 53.98*77.8*12.7 TC | 2.125*3.063*0.500 TC | 53.98 | 77.8 | | 12.7 | |
| FSG0308NB | 35*78*8 TC | | 35 | 78 | | 8 | |
| FSG0596NB | 40*78*8 TC | | 40 | 78 | | 8 | |
| FSG0669NB | 40*78*10 SC | | 40 | 78 | | 10 | |
| FSG0681NB | 40*78/84.5*13.5/18 Y | (BUGA5)AZ8137P;K7 Rotary | 40 | 78 | 84.5 | 13.5 | 18 |
| FSG0739NB | 42*78*10 TC | | 42 | 78 | | 10 | |
| FSG580NB | 45*78*8 SB | | 45 | 78 | | 8 | |
| FSG0599NB | 45*78*8 TC | | 45 | 78 | | 8 | |
| FSG0417NB | 45*78*10 TB | | 45 | 78 | | 10 | |
| FSG0425NB | 45*78*11/18 HTB9R | 8-94408-085-0 | 45 | 78 | | 11 | 18 |
| FSG0422NB | 45*78*12 TC | | 45 | 78 | | 12 | |
| FSG0492NB | 45*78*12/25.5 TM39 | 9-09724-005-0 | 45 | 78 | | 12 | 25.5 |
| FSG0273NB | 45*78/88*12/15 VC35A(Y) | 113AE04(KCX39Y) | 45 | 78 | 88 | 12 | 15 |
| FSG0671NB | 46*78*10 HTBR | | 46 | 78 | | 10 | |
| FSG0367NB | 46*78*10 TC | | 46 | 78 | | 10 | |
| FSG0740NB | 48*78*10 TC | | 48 | 78 | | 10 | |
| FSG0617NB | 50*78*8 TC | | 50 | 78 | | 8 | |
| FSG0456NB | 50*78*10 SC | | 50 | 78 | | 10 | |
| FSG0516NB | 50*78*10 TC | | 50 | 78 | | 10 | |
| FSG0435NB | 50*78*12 TC | | 50 | 78 | | 12 | |
| FSG0557NB | 52*78*9 TC | | 52 | 78 | | 9 | |
| FSG0554NB | 52*78*10 TC | | 52 | 78 | | 10 | |
| FSG0502NB | 54*78*12 SC | | 54 | 78 | | 12 | |
| FSG0619NB | 54*78*12 TC | | 54 | 78 | | 12 | |
| FSG0609NB | 54*78*13 TC | | 54 | 78 | | 13 | |
| FSG0373NB | 55*78*8 HTCR | ME-013306 | 55 | 78 | | 8 | |
| FSG0151NB | 55*78*8 TC | | 55 | 78 | | 8 | |
| FSG0207NB | 55*78*9 TC | | 55 | 78 | | 9 | |
| FSG0021NB | 55*78*10 TC | | 55 | 78 | | 10 | |
| FSG0021FB | 55*78*10 TC(VITON) | | 55 | 78 | | 10 | |
| FSG0430Q0 | 55*78*10/16.9 Y W/Felt | BZ5051E | 55 | 78 | | 10 | 16.9 |
| FSG0389NB | 55*78*12 DCY Brown | S269-26-154 MAZDA | 55 | 78 | | 12 | |
| FSG0512NB | 55*78*12 TB | 90311-55008 | 55 | 78 | | 12 | |
| FSG0020NB | 55*78*12 TC | ES THRUST SHAFT, 2S曲軸 | 55 | 78 | | 12 | |
| FSG0282NB | 55*78*12 TC3 | ME-024156 | 55 | 78 | | 12 | |
| FSG0282AB | 55*78*12 TC3(ACM) | | 55 | 78 | | 12 | |
| FSG0387NB | 55*78*12 TCN | AP3055F,NBR 85 | 55 | 78 | | 12 | |
| FSG0654NB | 55*78*12 TZ | | 55 | 78 | | 12 | |
| FSG0476NB | 56*78*7.5/13.5 TB9 | 90310-40001無研磨 | 56 | 78 | | 7.5 | 13.5 |
| FSG0649NB | 56*78*8 SC | | 56 | 78 | | 8 | |
| FSG0299NB | 58*78*8 TA2 | 90311-58001 | 58 | 78 | | 8 | |
| FSG0664NB | 58*78*10 TC | | 58 | 78 | | 10 | |
| FSG0454NB | 58*78*10/14 HTC9L(BROWN) | BH4366E | 58 | 78 | | 10 | 14 |
| FSG0742NB | 58*78*12 TC | | 58 | 78 | | 12 | |

| WLK CODE | OIL SEALS | DESCRIPTION | ID | OD1 | OD2 | H1 | H2 |
|-----------|---|---------------------------|-------|-------|-------|-------|-------|
| FSG0587NB | 60*78*7 TC | | 60 | 78 | | 7 | |
| FSG0733NB | 60*78*7 VB | | 60 | 78 | | 7 | |
| FSG0702FB | 60*78*8 TC(VITON) | | 60 | 78 | | 8 | |
| FSG0019NB | 60*78*9 TC | SM THRUST SHAFT | 60 | 78 | | 9 | |
| FSG0170N0 | 60*78*9/11 KB3 | BF3736E 前輪站軸 | 60 | 78 | | 9 | 11 |
| FSG0220NB | 60*78*10 TC | | 60 | 78 | | 10 | |
| FSG0165QB | 60.5*78*10 SC (VMQ) | (VMQ) | 60.5 | 78 | | 10 | |
| FSG0543NB | 62*78*7/9.5 KBW(KB9) | BF1668 WLK | 62 | 78 | | 7 | 9.5 |
| FSG0549NB | 62*78*10 TC | | 62 | 78 | | 10 | |
| FSG0424NB | 63*78*9/15 HTB9L | 9828-63108 | 63 | 78 | | 9 | 15 |
| FSG0461NB | 63*78*9/15 HTB9R | | 63 | 78 | | 9 | 15 |
| FSG0326NB | 65*78*9 HTCL(BROWN) | | 65 | 78 | | 9 | |
| FSG0482NB | 37*78.3*8/12 HTBC9Y | | 37 | 78.3 | | 8 | 12 |
| FSG9871NB | 42.88*78.3/83*11.91//13.75 HTB59Y | | 42.88 | 78.3 | 83 | 11.91 | 13.75 |
| FSG9870NB | 46.05*78.54/86.92*12.7/15.47 TB59Y | OD W/SEALANT | 46.05 | 78.54 | 86.92 | 12.7 | 15.47 |
| FSG9872NB | 42.88*78.63/87.91*13.89 TB5 Blue Painting | 17037 | 42.88 | 78.63 | 87.91 | 13.89 | |
| FSG0605NB | 53*79*10 TC | | 53 | 79 | | 10 | |
| FSG0265NB | 57*79*9/13.5 TB59Y | 40232-31G00 | 57 | 79 | | 9 | 13.5 |
| FSG0646NB | 57*79*10.5/16 TC9 | | 57 | 79 | | 10.5 | 16 |
| FSG0066NB | 58*79*9 TC | | 58 | 79 | | 9 | |
| FSG0301NB | 60*79*11 HTCR | V101 10 602 | 60 | 79 | | 11 | |
| FSG0340NB | 63*79*9 TC | | 63 | 79 | | 9 | |
| FSG0487NB | 65*79*7 HTCR | 90311-65003 | 65 | 79 | | 7 | |
| FSG0018NB | 68*79*11.5 Cover | 野馬(曳)4300前輪上蓋 | 68 | 79 | | 11.5 | |
| FSG0017NB | 58.72*79.37*9.5 HSCR | 2.312*3.125*0.374 HSCR | 58.72 | 79.37 | | 9.5 | |
| FSG9874EB | 58.72*79.37*9.5 HTGR(EPDM) | EPDM材質(Brown) | 58.72 | 79.37 | | 9.5 | |
| FSG9874NB | 58.72*79.37*9.5 HTGR Red | NBR紅色無商標 | 58.72 | 79.37 | | 9.5 | |
| FSG9884NB | 60.32*79.37*9.52 HTCL | | 60.32 | 79.37 | | 9.52 | |
| FSG9857NB | 60.32*79.37*9.52 SC | | 60.32 | 79.37 | | 9.52 | |
| FSG9876NB | 60.32*79.37*12.7 TA | | 60.32 | 79.37 | | 12.7 | |
| FSG0128NB | 49.12*79.38*12.5 SC | | 49.12 | 79.38 | | 12.5 | |
| FSG0277NB | 49.21*79.38*12.5/8 SGR | D9NN C729BA 黑灰合成 | 49.21 | 79.38 | | 12.5 | 8 |
| FSG9873NB | 50.8*79.38*12.7 TC | | 50.8 | 79.38 | | 12.7 | |
| FSG9863NB | 53.98*79.38*12.7 TA | | 53.98 | 79.38 | | 12.7 | |
| FSG0324NB | 57.15*79.38*9.5 SC | | 57.15 | 79.38 | | 9.5 | |
| FSG9964NB | 57.15*79.38*9.53 TC | | 57.15 | 79.38 | | 9.53 | |
| FSG9961NB | 58.75*79.38*9.53 TC | | 58.75 | 79.38 | | 9.53 | |
| FSG9965NB | 60.33*79.38*9.53 TA | | 60.33 | 79.38 | | 9.53 | |
| FSG9996NB | 60.33*79.38*9.53 TC | 2.375*3.125*0.375 TC | 60.33 | 79.38 | | 9.53 | |
| FSG9996FB | 60.33*79.38*9.53 TC(FKM) | 2.375*3.125*0.375 TC(FKM) | 60.33 | 79.38 | | 9.53 | |
| FSG9862NB | 61.93*79.38*9.53 TC | | 61.93 | 79.38 | | 9.53 | |
| FSG9967NB | 69.85*79.38*4.78 VB(BLUE) | | 69.85 | 79.38 | | 4.78 | |
| FSG0107NB | 59.06*79.43*9.27 HTC | 2.325*3.127*0.365 HTC | 59.06 | 79.43 | | 9.27 | |
| FSG9860NB | 59.06*79.43*9.27 HTG | | 59.06 | 79.43 | | 9.27 | |
| FSG9860FB | 59.06*79.43*9.27 HTG(FKM) | VITON | 59.06 | 79.43 | | 9.27 | |
| FSG0255NB | 59.54*79.45*9.53 TB Orange Painting | 2.344*3.128*0.375 TB | 59.54 | 79.45 | | 9.53 | |
| FSG0126NB | 48*79.5*12.5 SC | | 48 | 79.5 | | 12.5 | |
| FSG0160QB | 58*79.5*9 HSCR (VMQ) | | 58 | 79.5 | | 9 | |
| FSG0092NB | 59*79.5*9.5 TB (Painting OD) | | 59 | 79.5 | | 9.5 | |
| FSG0016NB | 59*79.5*9.5 TBP | 2.323*3.130*0.374 TBP | 59 | 79.5 | | 9.5 | |
| FSG9853N0 | 63.5*79.5*8 KAJR | 2.500*3.130*0.315 KAJR | 63.5 | 79.5 | | 8 | |
| FSG0700NB | 53.98*79.78*11.13/14.68 TZY | MTM3859 TATA CAR | 53.98 | 79.78 | | 11.13 | 14.68 |
| FSG9868NB | 53.98*79.98*9.9/12.7 HTBG | | 53.98 | 79.98 | | 9.9 | 12.7 |
| FSG0199NB | 30*80*10 TC | | 30 | 80 | | 10 | |
| FSG0493NB | 35*80*8 TC | | 35 | 80 | | 8 | |
| FSG0493FB | 35*80*8 TC(VITON) | | 35 | 80 | | 8 | |

| WLK CODE | OIL SEALS | DESCRIPTION | ID | OD1 | OD2 | H1 | H2 |
|-----------|----------------------------|----------------|------|-----|------|------|------|
| FSG0222NB | 35*80*10 TC | | 35 | 80 | | 10 | |
| FSG0222FB | 35*80*10 TC(VITON) | | 35 | 80 | | 10 | |
| FSG0169NB | 35*80*12 SC | | 35 | 80 | | 12 | |
| FSG0343NB | 35*80*12 TC | | 35 | 80 | | 12 | |
| FSG0240NB | 35*80*13 TC | | 35 | 80 | | 13 | |
| FSG0592NB | 37*80*12 SC | | 37 | 80 | | 12 | |
| FSG0594NB | 38*80*8 TC | | 38 | 80 | | 8 | |
| FSG0694NB | 38*80*10 SC | | 38 | 80 | | 10 | |
| FSG0494NB | 38*80*10 TC | | 38 | 80 | | 10 | |
| FSG0510NB | 40*80*7 TC | | 40 | 80 | | 7 | |
| FSG0636NB | 40*80*8 SC | | 40 | 80 | | 8 | |
| FSG0484NB | 40*80*8 TC | | 40 | 80 | | 8 | |
| FSG0484FB | 40*80*8 TC(VITON) | | 40 | 80 | | 8 | |
| FSG0683FB | 40*80*10 SC(VITON) | | 40 | 80 | | 10 | |
| FSG0010NB | 40*80*10 TC | | 40 | 80 | | 10 | |
| FSG0010FB | 40*80*10 TC(FKM)VITON | | 40 | 80 | | 10 | |
| FSG0171NB | 40*80*12 TC | | 40 | 80 | | 12 | |
| FSG0009NB | 40*80/88*12.5 TC6Y(TCU5) | ER8Hp 主齒輪箱部牛腳 | 40 | 80 | 88 | 12.5 | |
| FSG0573NB | 40*80*13 TC | | 40 | 80 | | 13 | |
| FSG0490NB | 40.2*80/88*8/15 TGAY | | 40.2 | 80 | 88 | 8 | 15 |
| FSG0504NB | 40.2*80/95*10/15 VGA5Y | 03AT87 | 40.2 | 80 | 95 | 10 | 15 |
| FSG0140NB | 42*80*10 SA Green Painting | | 42 | 80 | | 10 | |
| FSG0457NB | 42*80*10 TC | | 42 | 80 | | 10 | |
| FSG0500NB | 43*80*10 SC | | 43 | 80 | | 10 | |
| FSG0344NB | 44*80*9/15.5 HTC9Y | 90311-44003 | 44 | 80 | | 9 | 15.5 |
| FSG0568NB | 45*80*8 TC | | 45 | 80 | | 8 | |
| FSG0173NB | 45*80*10 TC | | 45 | 80 | | 10 | |
| FSG0173FB | 45*80*10 TC(VITON) | | 45 | 80 | | 10 | |
| FSG0172NB | 45*80*10/16.5 TCY(TC9) | 90043-11148 | 45 | 80 | | 10 | 16.5 |
| FSG0737NB | 45*80/91.5*10/18 Y | | 45 | 80 | 91.5 | 10 | 18 |
| FSG0274NB | 45*80*12 TC | | 45 | 80 | | 12 | |
| FSG0274FB | 45*80*12 TC(VITON) | | 45 | 80 | | 12 | |
| FSG0710NB | 45*80*13 SC | | 45 | 80 | | 13 | |
| FSG0635NB | 45*80*13 TC | | 45 | 80 | | 13 | |
| FSG0565NB | 47*80*10 TC | | 47 | 80 | | 10 | |
| FSG0691NB | 47*80*10/12 TG49Y | 613084or416363 | 47 | 80 | | 10 | 12 |
| FSG0652NB | 47*80*10/16 HTC9W | | 47 | 80 | | 10 | 16 |
| FSG0501NB | 48*80*8 SC | | 48 | 80 | | 8 | |
| FSG0290NB | 48*80*8 TC | | 48 | 80 | | 8 | |
| FSG0576NB | 48*80*10 TA | | 48 | 80 | | 10 | |
| FSG0279NB | 48*80*10 TC | | 48 | 80 | | 10 | |
| FSG0279FB | 48*80*10 TC(VITON) | | 48 | 80 | | 10 | |
| FSG0239NB | 48*80*12 TC | | 48 | 80 | | 12 | |
| FSG0439NB | 48*80*13 TC | | 48 | 80 | | 13 | |
| FSG0394NB | 48*80*14 TB | | 48 | 80 | | 14 | |
| FSG0693NB | 48*80*14 TC3 | | 48 | 80 | | 14 | |
| FSG0238NB | 50*80*7 TC | | 50 | 80 | | 7 | |
| FSG0352NB | 50*80*8 SC | | 50 | 80 | | 8 | |
| FSG0236NB | 50*80*8 TC | | 50 | 80 | | 8 | |
| FSG0236FB | 50*80*8 TC (FKM)VITON | | 50 | 80 | | 8 | |
| FSG0236QB | 50*80*8 TC(VMQ) | | 50 | 80 | | 8 | |
| FSG0008NB | 50*80*10 SC | | 50 | 80 | | 10 | |
| FSG0008FB | 50*80*10 SC(VITON) | TC修掉副唇 | 50 | 80 | | 10 | |
| FSG0014NB | 50*80*10 TC | | 50 | 80 | | 10 | |
| FSG0014FB | 50*80*10 TC (FKM)VITON | | 50 | 80 | | 10 | |
| FSG0462NB | 50*80*11 TC | | 50 | 80 | | 11 | |
| FSG0464NB | 50*80*11/18 HTC9L(BROWN) | 90311-50024 | 50 | 80 | | 11 | 18 |

| WLK CODE | OIL SEALS | DESCRIPTION | ID | OD1 | OD2 | H1 | H2 |
|-----------|-----------------------------|-----------------------|----|-----|-----|------|----|
| FSG0007NB | 50*80*12 SC | DF195 曲軸 | 50 | 80 | | 12 | |
| FSG0174NB | 50*80*12 TC | | 50 | 80 | | 12 | |
| FSG0006NB | 50*80*13 SA2 Green Painting | PF195 | 50 | 80 | | 13 | |
| FSG0434NB | 50*80*13 TC | | 50 | 80 | | 13 | |
| FSG0434FB | 50*80*13 TC(VITON) | | 50 | 80 | | 13 | |
| FSG0328NB | 50*80*14 TC | | 50 | 80 | | 14 | |
| FSG0738NB | 50*80*16.5/23 TC9Y | 90311-50010 | 50 | 80 | | 16.5 | 23 |
| FSH0816NB | 52*80*8 TC | | 52 | 80 | | 8 | |
| FSH0150NB | 52*80*10 SC | | 52 | 80 | | 10 | |
| FSH0196NB | 52*80*10 TC | | 52 | 80 | | 10 | |
| FSH0813NB | 52*80*13 SC | | 52 | 80 | | 13 | |
| FSH0155NB | 52*80*13 TC | | 52 | 80 | | 13 | |
| FSG0315NB | 53*80*10 TC | | 53 | 80 | | 10 | |
| FSG0508NB | 54*80*10 SA | | 54 | 80 | | 10 | |
| FSG0436NB | 54*80*10 SB | | 54 | 80 | | 10 | |
| FSG0204NB | 54*80*10 TC | | 54 | 80 | | 10 | |
| FSG0586NB | 54*80*13 TC | | 54 | 80 | | 13 | |
| FSG0713NB | 55*80*6 SC | | 55 | 80 | | 6 | |
| FSG0175NB | 55*80*8 SB | | 55 | 80 | | 8 | |
| FSG0717FB | 55*80*8 TA(VITON) | | 55 | 80 | | 8 | |
| FSG0208NB | 55*80*8 TC | | 55 | 80 | | 8 | |
| FSG0208FB | 55*80*8 TC(VITON) | | 55 | 80 | | 8 | |
| FSG0535NB | 55*80*10 SC | | 55 | 80 | | 10 | |
| FSG0535FB | 55*80*10 SC(VITON) | | 55 | 80 | | 10 | |
| FSG0261NB | 55*80*10 TC | | 55 | 80 | | 10 | |
| FSG0261FB | 55*80*10 TC(VITON)FKM | | 55 | 80 | | 10 | |
| FSG0463NB | 55*80*11 TC | | 55 | 80 | | 11 | |
| FSG0628FB | 55*80*12 SC(VITON) | TC型修掉副唇 | 55 | 80 | | 12 | |
| FSG0015NB | 55*80*12 TC | | 55 | 80 | | 12 | |
| FSG0015FB | 55*80*12 TC (FKM)VITON | | 55 | 80 | | 12 | |
| FSG0687NB | 55*80*13 SA | | 55 | 80 | | 13 | |
| FSG0093NB | 55*80*13 TBY | | 55 | 80 | | 13 | |
| FSG0390NB | 55*80*13 TC | | 55 | 80 | | 13 | |
| FSG0390QB | 55*80*13 TC(VMQ) | | 55 | 80 | | 13 | |
| FSG0480NB | 56*80*8 TC | | 56 | 80 | | 8 | |
| FSG0584NB | 56*80*10 TB | | 56 | 80 | | 10 | |
| FSG0677NB | 56*80*12 TC | | 56 | 80 | | 12 | |
| FSG0088NB | 56*80*13 TBY | | 56 | 80 | | 13 | |
| FSG0211NB | 56*80*13 TC | | 56 | 80 | | 13 | |
| FSG0011NB | 57*80*12 TC | | 57 | 80 | | 12 | |
| FSG0177NB | 57*80*13 TBY | | 57 | 80 | | 13 | |
| FSG0396NB | 58*80*8 SC | | 58 | 80 | | 8 | |
| FSG0320NB | 58*80*8 TC | | 58 | 80 | | 8 | |
| FSG0178NB | 58*80*9 TC | 0604-26-154 | 58 | 80 | | 9 | |
| FSG0179NB | 58*80*10 SC | | 58 | 80 | | 10 | |
| FSG0152NB | 58*80*10 TB | | 58 | 80 | | 10 | |
| FSG0216NB | 58*80*10 TC | | 58 | 80 | | 10 | |
| FSG0216FB | 58*80*10 TC(VITON) | | 58 | 80 | | 10 | |
| FSG0180NB | 58*80*12 HTCL | ST95/SS4 曲軸 | 58 | 80 | | 12 | |
| FSG0281NB | 58*80*12 HTCR | 13043-T7200 | 58 | 80 | | 12 | |
| FSG0181NB | 58*80*12 SC (Blue) | KD THRUST SHAFT | 58 | 80 | | 12 | |
| FSG0005NB | 58*80*12 TC | AE3254A | 58 | 80 | | 12 | |
| FSG0103NB | 58*80/88*12 HTC5R | SD22 CRANKSHAFT FRONT | 58 | 80 | 88 | 12 | |
| FSG0276NB | 58*80/88*12 HTC5R(WLK) | 13043-76200 | 58 | 80 | 88 | 12 | |
| FSG0004NB | 58*80*13 TBY | NT85/95/PMY5/F7/F8 曲軸 | 58 | 80 | | 13 | |
| FSG0391NB | 58*80*13 TC | | 58 | 80 | | 13 | |
| FSG0391QB | 58*80*13 TC(VMQ) | | 58 | 80 | | 13 | |

| WLK CODE | OIL SEALS | DESCRIPTION | ID | OD1 | OD2 | H1 | H2 |
|-----------|--------------------------|-----------------|----|-----|------|-----|----|
| FSG0610NB | 59*80*10 SC | | 59 | 80 | | 10 | |
| FSG0361NB | 60*80*7 TC | | 60 | 80 | | 7 | |
| FSG0361FB | 60*80*7 TC(VITON) | | 60 | 80 | | 7 | |
| FSG0701N0 | 60*80*7/10 GA(NBR90) | | 60 | 80 | | 7 | 10 |
| FSG0013NB | 60*80*8 HTCL | 09283-60005 | 60 | 80 | | 8 | |
| FSG0659FB | 60*80*8 SC(VITON) | | 60 | 80 | | 8 | |
| FSG0729NB | 60*80*8 TB | | 60 | 80 | | 8 | |
| FSG0221NB | 60*80*8 TC | | 60 | 80 | | 8 | |
| FSG0221AB | 60*80*8 TC(ACM) | | 60 | 80 | | 8 | |
| FSG0221FB | 60*80*8 TC(VITON)FKM | | 60 | 80 | | 8 | |
| FSG0221QB | 60*80*8 TC(VMQ) | | 60 | 80 | | 8 | |
| FSG0690NB | 60*80/82.5*9/12 DCY | | 60 | 80 | 82.5 | 9 | 12 |
| FSG0575FB | 60*80*10 SC(VITON) | TC修掉副唇 | 60 | 80 | | 10 | |
| FSG0003NB | 60*80*10 TC | | 60 | 80 | | 10 | |
| FSG0003FB | 60*80*10 TC(FKM)VITON | | 60 | 80 | | 10 | |
| FSG0191NB | 60*80/90*11 SCY | 1SM, AQ8290P | 60 | 80 | 90 | 11 | |
| FSG0645FB | 60*80*12 SC(VITON) | | 60 | 80 | | 12 | |
| FSG0002NB | 60*80*12 TC | SM CAM SHAFT | 60 | 80 | | 12 | |
| FSG0002NS | 60*80*12 TC (S304SPRING) | SUS304 SPRING | 60 | 80 | | 12 | |
| FSG0002FB | 60*80*12 TC(FKM)VITON | | 60 | 80 | | 12 | |
| FSG0497NB | 60*80*12 TZ | | 60 | 80 | | 12 | |
| FSG0419NB | 60*80*13 TC | | 60 | 80 | | 13 | |
| FSG0419QB | 60*80*13 TC(VMQ) | | 60 | 80 | | 13 | |
| FSG0544NB | 62*80*8 TC(BROWN) | | 62 | 80 | | 8 | |
| FSG0001NB | 62*80*9 TC | TS230C 曲軸 | 62 | 80 | | 9 | |
| FSG0001AB | 62*80*9 TC (ACM) | | 62 | 80 | | 9 | |
| FSG0184NB | 62*80*10 SA | | 62 | 80 | | 10 | |
| FSG0183NB | 62*80*10 TA2 | | 62 | 80 | | 10 | |
| FSG0223NB | 62*80*10 TC | | 62 | 80 | | 10 | |
| FSG0223FB | 62*80*10 TC(VITON) | | 62 | 80 | | 10 | |
| FSG0327NB | 62*80*11 TC | | 62 | 80 | | 11 | |
| FSG0684NB | 62*80*12 TC | | 62 | 80 | | 12 | |
| FSG0185NB | 62*80*12 TC4 | | 62 | 80 | | 12 | |
| FSG0438NB | 63*80*7.7 TB | AD3315E | 63 | 80 | | 7.7 | |
| FSG0697NB | 63*80*8 SC | | 63 | 80 | | 8 | |
| FSG0186NB | 63*80*9 HTCL | 曲軸用, D850,ZB600 | 63 | 80 | | 9 | |
| FSG0339NB | 63*80*9 TC | 90043-11060 | 63 | 80 | | 9 | |
| FSG0651NB | 63*80*10 TC | | 63 | 80 | | 10 | |
| FSG0380NB | 64*80*8 HSBL | | 64 | 80 | | 8 | |
| FSG0012NB | 64*80*8 HTBL | | 64 | 80 | | 8 | |
| FSG0714NB | 64*80*8 SC | | 64 | 80 | | 8 | |
| FSG0187NB | 64*80*8 TC | | 64 | 80 | | 8 | |
| FSG0188NB | 64*80*9 TC | | 64 | 80 | | 9 | |
| FSG0634NB | 64*80*10 TC | | 64 | 80 | | 10 | |
| FSG0189NB | 64*80*13 TC4 | | 64 | 80 | | 13 | |
| FSG0517NB | 65*80*5 VA | | 65 | 80 | | 5 | |
| FSH0086NB | 65*80*8 SB | | 65 | 80 | | 8 | |
| FSG0672QB | 65*80*8 SC(VMQ) | | 65 | 80 | | 8 | |
| FSG0190NB | 65*80*8 TC | | 65 | 80 | | 8 | |
| FSG0190FB | 65*80*8 TC(VITON) | | 65 | 80 | | 8 | |
| FSG0245NB | 65*80*9 TC | ACESIL商標 | 65 | 80 | | 9 | |
| FSG0423NB | 65*80*10 TB | SAMCOR | 65 | 80 | | 10 | |
| FSG0224NB | 65*80*10 TC | | 65 | 80 | | 10 | |
| FSG0224FB | 65*80*10 TC(FKM)VITON | | 65 | 80 | | 10 | |
| FSG0506NB | 65*80*10/17 HTB9L | 9828-65112A | 65 | 80 | | 10 | 17 |
| FSG0362NB | 65*80*12 SC | | 65 | 80 | | 12 | |
| FSG0342NB | 65*80*12 TC | | 65 | 80 | | 12 | |

| WLK CODE | OIL SEALS | DESCRIPTION | ID | OD1 | OD2 | H1 | H2 |
|------------|---------------------------------------|-----------------------|-------|-------|-------|-------|-------|
| FSG0625NB | 65*80*13 SC | | 65 | 80 | | 13 | |
| FSG0376NB | 66*80*9 TA | 90311-66002 | 66 | 80 | | 9 | |
| FSH0321NB | 68*80*8 SC | | 68 | 80 | | 8 | |
| FSH0130NB | 68*80*10 TC | | 68 | 80 | | 10 | |
| FSG0540NB | 70*80*7/10 GA | | 70 | 80 | | 7 | 10 |
| FSG0615NB | 70*80*8 TC | | 70 | 80 | | 8 | |
| FSH0220NB | 70*80*10 TC | | 70 | 80 | | 10 | |
| FSH0812NB | 70*80*12 TC | | 70 | 80 | | 12 | |
| FSH9976NB | 39.29*80.16*7.14/18.64 TB9Y | AD2314E | 39.29 | 80.16 | | 7.14 | 18.64 |
| FSH0202NB | 47.63*80.16*14.3 SA | | 47.63 | 80.16 | | 14.3 | |
| FSH9943NB | 39.42*80.26/70.5*6.76/16.89 TB59Y | OD W/SEALANT | 39.42 | 80.26 | 70.5 | 6.76 | 16.89 |
| FSH9942NB | 39.42*80.26/71.04*13.46/16.66 TBA59Y | | 39.42 | 80.26 | 71.04 | 13.46 | 16.66 |
| FSH9997NB | 53.98*80.95*12.7 TC | 2.125*3.187*0.500 TC | 53.98 | 80.95 | | 12.7 | |
| FSH9938NB | 57.15*80.96*12.7 SC | | 57.15 | 80.96 | | 12.7 | |
| FSH9919NB | 57.15*80.96*12.7 TC | | 57.15 | 80.96 | | 12.7 | |
| FSH9926NB | 44.45*80.98*12.7 SC | | 44.45 | 80.98 | | 12.7 | |
| FSH0427NB | 44.45*80.98*12.7 TC | | 44.45 | 80.98 | | 12.7 | |
| FSH9950NB | 47.63*80.98*12.7 TA | | 47.63 | 80.98 | | 12.7 | |
| FSH9940NB | 50.8*80.98*12.7 TC | | 50.8 | 80.98 | | 12.7 | |
| FSH9944NB | 53.97*80.98*9.53 TC | | 53.97 | 80.98 | | 9.53 | |
| FSH9956NB | 53.97*80.98*11.91 TB | | 53.97 | 80.98 | | 11.91 | |
| FSH9984NB | 53.98*80.98*12.7 TC | | 53.98 | 80.98 | | 12.7 | |
| FSH9939NB | 55.58*80.98*12.7 SC | | 55.58 | 80.98 | | 12.7 | |
| FSH9960NB | 57.15*80.98*11.51 HTBRY BLUE PAINTING | | 57.15 | 80.98 | | 11.51 | |
| FSH0397NB | 50*81*13 TC | | 50 | 81 | | 13 | |
| FSH0221NB | 52*81*11 TC | | 52 | 81 | | 11 | |
| FSH0248NB | 54*81*10 TC | PEUGEOT 334522 | 54 | 81 | | 10 | |
| FSH02040NB | 54*81*12 TC | | 54 | 81 | | 12 | |
| FSH0364NB | 55*81*11 TC | | 55 | 81 | | 11 | |
| FSH0278NB | 56*81*8 TB | | 56 | 81 | | 8 | |
| FSH0241NB | 57*81*8/11 TB9 | 90311-57001 | 57 | 81 | | 8 | 11 |
| FSH0257NB | 60*81*11 HTCKR W/Felt | BH4171E | 60 | 81 | | 11 | |
| FSH0253NB | 60*81*11 HTCR | | 60 | 81 | | 11 | |
| FSH0228NB | 65*81*7 HTCR | | 65 | 81 | | 7 | |
| FSH0048NB | 46*81.03*10 TB | 1.811*3.190*0.394 TB | 46 | 81.03 | | 10 | |
| FSH0157P0 | 49.40*81.13*11.18 VAJR | 1.945*3.194*0.44 VAJR | 49.4 | 81.13 | | 11.18 | |
| FSH0848NB | 42*82*10 TC | | 42 | 82 | | 10 | |
| FSH0395NB | 45*82*8 TC | | 45 | 82 | | 8 | |
| FSH0407NB | 48*82*10 TC | | 48 | 82 | | 10 | |
| FSH0374NB | 48*82*10.5/17.5 HTC Brown | 90311-48019 | 48 | 82 | | 10.5 | 17.5 |
| FSH0049NB | 48*82*12 HTBR | 90311-48135 | 48 | 82 | | 12 | |
| FSH0213NB | 48*82*12 TC | | 48 | 82 | | 12 | |
| FSH0423NB | 48*82*12/19 HTB9W | W/AH2802F | 48 | 82 | | 12 | 19 |
| FSH0195NB | 50*82*8/11 TB9Y | MB-303867 | 50 | 82 | | 8 | 11 |
| FSH0800NB | 50*82*10 TC | | 50 | 82 | | 10 | |
| FSH0052NB | 50*82*12 HTCR | 90043-11059 | 50 | 82 | | 12 | |
| FSH0333NB | 50*82*12 TC | | 50 | 82 | | 12 | |
| FSH0268NB | 52*82*8 TB | | 52 | 82 | | 8 | |
| FSH0238NB | 54*82*8/11 TB9 | MB-808443 | 54 | 82 | | 8 | 11 |
| FSH0215NB | 54*82*10 TB | | 54 | 82 | | 10 | |
| FSH0030NB | 54*82*10 TC | | 54 | 82 | | 10 | |
| FSH0432NB | 54*82*11 TC | | 54 | 82 | | 11 | |
| FSH0216NB | 55*82*10 TC | | 55 | 82 | | 10 | |
| FSH0224NB | 55*82*10 VB | | 55 | 82 | | 10 | |
| FSH0082N0 | 55*82*10 VB2P | 90312-55010 | 55 | 82 | | 10 | |
| FSH0267NB | 55*82*12 TA | | 55 | 82 | | 12 | |
| FSH0207NB | 55*82*12 TC | | 55 | 82 | | 12 | |

| WLK CODE | OIL SEALS | DESCRIPTION | ID | OD1 | OD2 | H1 | H2 |
|-----------|-----------------------------|---------------------------|-------|-------|-----|-------|----|
| FSH0067NB | 58*82*9 TC | | 58 | 82 | | 9 | |
| FSG0297NB | 58*82*10 HTCR | 12276-Z5501 | 58 | 82 | | 10 | |
| FSG0667NB | 58*82*10 TC | | 58 | 82 | | 10 | |
| FSG0555NB | 58*82*12 TC(BROWN) | | 58 | 82 | | 12 | |
| FSH0314NB | 60*82*7 KC | 40227-J5110 | 60 | 82 | | 7 | |
| FSH0390NB | 60*82*8 SC | | 60 | 82 | | 8 | |
| FSH0380FB | 60*82*8 TC(VITON)FKM | | 60 | 82 | | 8 | |
| FSH0422NB | 60*82*9 HTCL(BROWN) | W/AH3220F W.O WLK | 60 | 82 | | 9 | |
| FSH0024NB | 60*82*9 TC | 90043-11042 | 60 | 82 | | 9 | |
| FSH0217NB | 60*82*10 TC | | 60 | 82 | | 10 | |
| FSH0294QB | 60*82*12 HTCKR VMQ W/Felt | | 60 | 82 | | 12 | |
| FSH0294NB | 60*82*12 HTCKR W/Felt | 109625-3190 | 60 | 82 | | 12 | |
| FSH0023NB | 60*82*12 HTCL | 12279-H1000 | 60 | 82 | | 12 | |
| FSH0036NB | 60*82*12 HTCR | NISSAN FD6T, 12278-Z5500 | 60 | 82 | | 12 | |
| FSH0820FB | 60*82*12 SC(VITON) | | 60 | 82 | | 12 | |
| FSH0801NB | 60*82*12 TB | | 60 | 82 | | 12 | |
| FSH0033NB | 60*82*12 TC | 12279-18000 | 60 | 82 | | 12 | |
| FSH0033NS | 60*82*12 TC (S304 SPRING) | SUS304 SPRING | 60 | 82 | | 12 | |
| FSH0033FB | 60*82*12 TC(FKM)VITON | | 60 | 82 | | 12 | |
| FSH0265NB | 60*82*12 TCN | AP3222B | 60 | 82 | | 12 | |
| FSH0386NB | 62*82*10 TC | | 62 | 82 | | 10 | |
| FSH0264NB | 62*82*11 TC | | 62 | 82 | | 11 | |
| FSH0237NB | 64*82*8 TC | | 64 | 82 | | 8 | |
| FSH0239NB | 64*82*9 TC | | 64 | 82 | | 9 | |
| FSH0371NB | 65*82*5/8 TB9 | | 65 | 82 | | 5 | 8 |
| FSH0308NB | 65*82*8/14 TB9 | UC86-33-065A | 65 | 82 | | 8 | 14 |
| FSH0646NB | 65*82*10 SC | | 65 | 82 | | 10 | |
| FSH0342NB | 65*82*10 TC | | 65 | 82 | | 10 | |
| FSH0022NB | 65*82*12 TC | | 65 | 82 | | 12 | |
| FSH0435NB | 67*82*7 TC | | 67 | 82 | | 7 | |
| FSH0230NB | 68*82*7 SC | | 68 | 82 | | 7 | |
| FSH0194NB | 68*82*7 TC | | 68 | 82 | | 7 | |
| FSH0839NB | 68*82*10 SC | | 68 | 82 | | 10 | |
| FSH0356NB | 70*82*12 TB | | 70 | 82 | | 12 | |
| FSH9969NB | 47.63*82.55*12.7 TC | | 47.63 | 82.55 | | 12.7 | |
| FSH9977NB | 53.97*82.55*9.52 TC | | 53.97 | 82.55 | | 9.52 | |
| FSH9961NB | 53.97*82.55*11.13 SA | | 53.97 | 82.55 | | 11.13 | |
| FSH0814NB | 53.98*82.55*9.53 TC | | 53.98 | 82.55 | | 9.53 | |
| FSH9923FB | 57.15*82.55*9.53 TB(FKM) | | 57.15 | 82.55 | | 9.53 | |
| FSH9968NB | 57.15*82.55*9.53 TC | | 57.15 | 82.55 | | 9.53 | |
| FSH0123NB | 57.15*82.55*12.7 SC | | 57.15 | 82.55 | | 12.7 | |
| FSH9974NB | 57.15*82.55*12.7 TA | | 57.15 | 82.55 | | 12.7 | |
| FSH9998NB | 57.15*82.55*12.7 TB | 2.25*3.25*0.50 TB | 57.15 | 82.55 | | 12.7 | |
| FSH9955NB | 57.15*82.55*12.7 TC | 2.250*3.250*0.500 TC | 57.15 | 82.55 | | 12.7 | |
| FSH9955FB | 57.15*82.55*12.7 TC(FKM) | 2.250*3.250*0.500 TC(FKM) | 57.15 | 82.55 | | 12.7 | |
| FSD0452NB | 58.75*82.55*12.29 SCB | 2.313*3.25*0.484 SCB刀角 | 58.75 | 82.55 | | 12.29 | |
| FSH9932EB | 60.33*82.55*9.53 HTGR(EPDM) | | 60.33 | 82.55 | | 9.53 | |
| FSH9932NB | 60.33*82.55*9.53 HTGR RED | | 60.33 | 82.55 | | 9.53 | |
| FSH9958NB | 60.33*82.55*9.53 TB | | 60.33 | 82.55 | | 9.53 | |
| FSH9967NB | 60.33*82.55*9.53 TC | | 60.33 | 82.55 | | 9.53 | |
| FSH9922NB | 60.33*82.55*12.7 SC | | 60.33 | 82.55 | | 12.7 | |
| FSG9908NB | 60.33*82.55*12.7 TC | | 60.33 | 82.55 | | 12.7 | |
| FSG9889NB | 61.93*82.55*9.53 TC | 2.438*3.250*0.375 TC | 61.93 | 82.55 | | 9.53 | |
| FSH0233NB | 63.5*82.55*9.5 TC (G122) | 2.500*3.250*0.37 TC | 63.5 | 82.55 | | 9.5 | |
| FSH0145NB | 63.5*82.55*9.53 SC | 2.500*3.250*0.375 SC | 63.5 | 82.55 | | 9.53 | |
| FSH9972NB | 63.5*82.55*9.53 TB | | 63.5 | 82.55 | | 9.53 | |
| FSH9988NB | 63.5*82.55*9.53 TC | 2.500*3.250*0.375 TC | 63.5 | 82.55 | | 9.53 | |

| WLK CODE | OIL SEALS | DESCRIPTION | ID | OD1 | OD2 | H1 | H2 |
|-----------|--------------------------------|--------------------------|-------|-------|-------|-------|------|
| FSH9988FB | 63.5*82.55*9.53 TC(VITON | 2.500*3.250*0.375 TC(FKM | 63.5 | 82.55 | | 9.53 | |
| FSH9992NB | 63.5*82.55*11.11 TB | 2.500*3.250*0.438 TB | 63.5 | 82.55 | | 11.11 | |
| FSH9989NB | 63.5*82.55*11.13 TB | | 63.5 | 82.55 | | 11.13 | |
| FSH9989FB | 63.5*82.55*11.13 TB(FKM) | | 63.5 | 82.55 | | 11.13 | |
| FSH9962NB | 63.5*82.55*12.7 SC | | 63.5 | 82.55 | | 12.7 | |
| FSH9973NB | 63.5*82.55*12.7 TA | | 63.5 | 82.55 | | 12.7 | |
| FSH0206NB | 63.5*82.55*12.7 TC | | 63.5 | 82.55 | | 12.7 | |
| FSH0118NB | 63.5*82.65*9.5 SC D450 | 2.500*3.250*0.374 SC | 63.5 | 82.65 | | 9.5 | |
| FSH0393NB | 36*83*12 SC | | 36 | 83 | | 12 | |
| FSH0328NB | 62*83/92*6.5/17 TB59Y | BD4996E | 62 | 83 | 92 | 6.5 | 17 |
| FSH0218NB | 62*83*9 TC | | 62 | 83 | | 9 | |
| FSH0379NB | 63*83*10 TC | | 63 | 83 | | 10 | |
| FSH0425NB | 67*83*7/10 GA | | 67 | 83 | | 7 | 10 |
| FSH0350NB | 68*83*10 HTCKL W/Felt | | 68 | 83 | | 10 | |
| FSH0349NB | 68*83*10 HTCL(BROWN) | | 68 | 83 | | 10 | |
| FSH0226NB | 68*83*10 TC | | 68 | 83 | | 10 | |
| FSH9995NB | 63.5*83.90/90.88*9.53 HTB5 | 2.5*3.303/3.578*0.375HTB | 63.5 | 83.9 | 90.88 | 9.53 | |
| FSH0227NB | 46*84*9.5 TC | | 46 | 84 | | 9.5 | |
| FSH0305NB | 47*84*9.5/17.5 TC5Y | 90311-47003 | 47 | 84 | | 9.5 | 17.5 |
| FSH0280NB | 47*84*10 TC | | 47 | 84 | | 10 | |
| FSH0826NB | 47*84*12 TC | | 47 | 84 | | 12 | |
| FSH0398NB | 52*84*10 TC | | 52 | 84 | | 10 | |
| FSH0147NB | 52*84*14 HTB2R | MB-005157 | 52 | 84 | | 14 | |
| FSH0373NB | 56*84*10 TC(BROWN) | | 56 | 84 | | 10 | |
| FSH0299NB | 65*84*9 HTCR | | 65 | 84 | | 9 | |
| FSH0338NB | 65*84*9 TC | | 65 | 84 | | 9 | |
| FSH0095NB | 68*84*8.5 HTCL | 8067-68040 | 68 | 84 | | 8.5 | |
| FSH0246QB | 70.84*84*4 Semi-Seals(VMQ) | (VMQ) | 70.84 | 84 | | 4 | |
| FSH0419NB | 72*84/85.5*18 TBY | | 72 | 84 | 85.5 | 18 | |
| FSH9936FB | 55.58*84.15*13.11/14.3 Y VITON | VITON噴綠漆,2pcs組合 | 55.58 | 84.15 | | 13.11 | 14.3 |
| FSH9928NB | 57.15*84.94*12.7 TA | | 57.15 | 84.94 | | 12.7 | |
| FSH0135NB | 40*85*10 TC | | 40 | 85 | | 10 | |
| FSH0135FB | 40*85*10 TC(VITON) | | 40 | 85 | | 10 | |
| FSH0394NB | 42*85*8 SC | | 42 | 85 | | 8 | |
| FSH0444NB | 45*85*8 TC | | 45 | 85 | | 8 | |
| FSH0044NB | 45*85*10 SC | | 45 | 85 | | 10 | |
| FSH0138NB | 45*85*10 TC | | 45 | 85 | | 10 | |
| FSH0138FB | 45*85*10 TC(FKM)VITON | | 45 | 85 | | 10 | |
| FSH0369NB | 45*85*12 TC | | 45 | 85 | | 12 | |
| FSH0045NB | 45*85*13 SA2 | | 45 | 85 | | 13 | |
| FSH0115NB | 45*85*13 SB | | 45 | 85 | | 13 | |
| FSH0153NB | 45*85*13 TC | | 45 | 85 | | 13 | |
| FSH0315NB | 48*85*10 TC | | 48 | 85 | | 10 | |
| FSH0050NB | 49.5*85*10 TB | | 49.5 | 85 | | 10 | |
| FSH0214NB | 50*85*8 TC | | 50 | 85 | | 8 | |
| FSH0053NB | 50*85*10 SC | | 50 | 85 | | 10 | |
| FSH0121NB | 50*85*10 TC | | 50 | 85 | | 10 | |
| FSH0370NB | 52*85*8 TC | | 52 | 85 | | 8 | |
| FSH0193NB | 52*85*10 TC | | 52 | 85 | | 10 | |
| FSH0343FB | 52*85*10 TC(VITON)FKM | | 52 | 85 | | 10 | |
| FSH0847NB | 52*85*12 TC | | 52 | 85 | | 12 | |
| FSH0408NB | 52*85*13 TC | | 52 | 85 | | 13 | |
| FSH0057NB | 54*85*10 TB | | 54 | 85 | | 10 | |
| FSH0433NB | 54*85*10 TC | | 54 | 85 | | 10 | |
| FSH0141FB | 55*85*8 SC(VITON) | | 55 | 85 | | 8 | |
| FSH0156NB | 55*85*8 TC | | 55 | 85 | | 8 | |
| FSH0156QB | 55*85*8 TC(VMQ) | | 55 | 85 | | 8 | |

| WLK CODE | OIL SEALS | DESCRIPTION | ID | OD1 | OD2 | H1 | H2 |
|-----------|-----------------------|---------------------|----|-----|-----|------|----|
| FSH0263NB | 55*85*9 TC | | 55 | 85 | | 9 | |
| FSH0060FB | 55*85*10 SC(VITON) | | 55 | 85 | | 10 | |
| FSH0245NB | 55*85*10 TB | | 55 | 85 | | 10 | |
| FSH0122NB | 55*85*10 TC | | 55 | 85 | | 10 | |
| FSH0122FB | 55*85*10 TC(VITON) | | 55 | 85 | | 10 | |
| FSH0311NB | 55*85*11 TC(BROWN) | | 55 | 85 | | 11 | |
| FSH0061NB | 55*85*12 TC | | 55 | 85 | | 12 | |
| FSH0296NB | 55*85*13 TC | | 55 | 85 | | 13 | |
| FSH0320NB | 55*85*14 TC | 咖啡色 | 55 | 85 | | 14 | |
| FSH0284NB | 56*85*8 TC | | 56 | 85 | | 8 | |
| FSH0807NB | 56*85*10 TC | | 56 | 85 | | 10 | |
| FSH0399NB | 57*85*10 SC | | 57 | 85 | | 10 | |
| FSH0208NB | 57*85*12 TC | | 57 | 85 | | 12 | |
| FSH0811NB | 57*85*13 TC | | 57 | 85 | | 13 | |
| FSH0360NB | 57*85*15 TC | | 57 | 85 | | 15 | |
| FSG0292NB | 57*85*16 TC6 | 52*85*16/19半成品 | 57 | 85 | | 16 | |
| FSH0381NB | 58*85*8 TC | | 58 | 85 | | 8 | |
| FSH0266NB | 58*85*10 SC | | 58 | 85 | | 10 | |
| FSH0249NB | 58*85*10 TC | | 58 | 85 | | 10 | |
| FSH0249FB | 58*85*10 TC(VITON)FKM | | 58 | 85 | | 10 | |
| FSH0409NB | 58*85*12 TC | | 58 | 85 | | 12 | |
| FSH0843NB | 58*85*13 TC | | 58 | 85 | | 13 | |
| FSH0837NB | 59*85*8 SC | | 59 | 85 | | 8 | |
| FSH0401NB | 59*85*12 TC | | 59 | 85 | | 12 | |
| FSH0832NB | 60*85*6 TC | | 60 | 85 | | 6 | |
| FSH0318NB | 60*85*8 SC | | 60 | 85 | | 8 | |
| FSH0143NB | 60*85*8 TC | | 60 | 85 | | 8 | |
| FSH0835FB | 60*85*10 SC(VITON) | | 60 | 85 | | 10 | |
| FSH0304NB | 60*85*10 TA | | 60 | 85 | | 10 | |
| FSH0310NB | 60*85*10 TB | | 60 | 85 | | 10 | |
| FSH0072NB | 60*85*10 TC | | 60 | 85 | | 10 | |
| FSH0072QB | 60*85*10 TC (VMQ) | | 60 | 85 | | 10 | |
| FSH0072FB | 60*85*10 TC(VITON) | | 60 | 85 | | 10 | |
| FSH0027NB | 60*85*12 SC | | 60 | 85 | | 12 | |
| FSH0073NB | 60*85*12 TC | MH-034066 | 60 | 85 | | 12 | |
| FSH0335NB | 60*85*12 TZ | | 60 | 85 | | 12 | |
| FSH0025NB | 60*85*12/14 TCY | | 60 | 85 | | 12 | 14 |
| FSG0413NB | 60*85*13 TC | | 60 | 85 | | 13 | |
| FSH0443NB | 61*85*13 TB | | 61 | 85 | | 13 | |
| FSH0212NB | 62*85*8 TB | | 62 | 85 | | 8 | |
| FSH0324NB | 62*85*8 TC | | 62 | 85 | | 8 | |
| FSH0077NB | 62*85*8/10 TA | 90311-62001/62147 | 62 | 85 | | 8 | 10 |
| FSH0322NB | 62*85*8/17 TA29Y | 90311-22103 | 62 | 85 | | 8 | 17 |
| FSH0011NB | 62*85*10 SA | | 62 | 85 | | 10 | |
| FSH0078NB | 62*85*10 TA | 90311-62001 (62147) | 62 | 85 | | 10 | |
| FSH0204NB | 62*85*10 TC | | 62 | 85 | | 10 | |
| FSH0046NB | 62*85*11 TCY | | 62 | 85 | | 11 | |
| FSH0199NB | 62*85*12 TC | | 62 | 85 | | 12 | |
| FSH0429NB | 62*85*12 TCN | | 62 | 85 | | 12 | |
| FSH0802NB | 62*85*12 TZ | | 62 | 85 | | 12 | |
| FSH0354NB | 62*85*12.5 HTCR | 12278-T9000,NJ371 | 62 | 85 | | 12.5 | |
| FSH0293NB | 62*85/93*13 HTC5R | 12278-90016 | 62 | 85 | 93 | 13 | |
| FSH0275NB | 62*85*13.5 SCY(SCRY) | 62*85/93*13 TC35 | 62 | 85 | | 13.5 | |
| FSH0275QB | 62*85*13.5 SCY(VMQ) | 62*85/93*13 TC35 | 62 | 85 | | 13.5 | |
| FSH0081NB | 63*85*10 TB(TM) | | 63 | 85 | | 10 | |
| FSH0283NB | 63*85*10 TC | | 63 | 85 | | 10 | |
| FSH0283FB | 63*85*10 TC(VITON) | | 63 | 85 | | 10 | |

| WLK CODE | OIL SEALS | DESCRIPTION | ID | OD1 | OD2 | H1 | H2 |
|-----------|------------------------|----------------------|-------|-------|-----|-------|-----|
| FSH0415NB | 63*85*12 TC | | 63 | 85 | | 12 | |
| FSH0416NB | 63*85*13 SC | | 63 | 85 | | 13 | |
| FSH0368NB | 63.5*85*12 TC3(BROWN) | 38189-50000 | 63.5 | 85 | | 12 | |
| FSH0276NB | 64*85*10 SA | | 64 | 85 | | 10 | |
| FSH0828NB | 64*85*10 SB | | 64 | 85 | | 10 | |
| FSH0271NB | 64*85*10 TC | | 64 | 85 | | 10 | |
| FSH0229NB | 64*85*12 TC | | 64 | 85 | | 12 | |
| FSH0430NB | 64*85*16 TC | | 64 | 85 | | 16 | |
| FSH0827NB | 65*85*8 SB | | 65 | 85 | | 8 | |
| FSH0243NB | 65*85*8 SC | | 65 | 85 | | 8 | |
| FSH0126NB | 65*85*8 TC | | 65 | 85 | | 8 | |
| FSH0126FB | 65*85*8 TC(VITON) | | 65 | 85 | | 8 | |
| FSH0261NB | 65*85*10 SA | | 65 | 85 | | 10 | |
| FSH0087NB | 65*85*10 SB | | 65 | 85 | | 10 | |
| FSH0841FB | 65*85*10 SC(VITON) | | 65 | 85 | | 10 | |
| FSH0029NB | 65*85*10 TB | 9-09724-023-0 | 65 | 85 | | 10 | |
| FSH0088NB | 65*85*10 TC | | 65 | 85 | | 10 | |
| FSH0088FB | 65*85*10 TC(VITON)FKM | | 65 | 85 | | 10 | |
| FSH0088QB | 65*85*10 TC(VMQ) | | 65 | 85 | | 10 | |
| FSH0834NB | 65*85*12 TA | | 65 | 85 | | 12 | |
| FSH0347NB | 65*85*12 TB | | 65 | 85 | | 12 | |
| FSH0142NB | 65*85*12 TC | 9-09984-023-0 | 65 | 85 | | 12 | |
| FSH0297NB | 65*85*13 TC | | 65 | 85 | | 13 | |
| FSH0297FB | 65*85*13 TC(VITON) | | 65 | 85 | | 13 | |
| FSH0148NB | 66*85*8/10 TA | 90311-66005/66001 | 66 | 85 | | 8 | 10 |
| FSH0445NB | 68*85*8 SC | | 68 | 85 | | 8 | |
| FSH0353NB | 68*85*8 TB | | 68 | 85 | | 8 | |
| FSH0131NB | 68*85*8 TC | | 68 | 85 | | 8 | |
| FSH0287NB | 68*85*10 SB | | 68 | 85 | | 10 | |
| FSH0132NB | 68*85*10 TC | | 68 | 85 | | 10 | |
| FSH0222NB | 68*85*12 TC | | 68 | 85 | | 12 | |
| FSH0412NB | 68*85*13 TC | | 68 | 85 | | 13 | |
| FSH0325NB | 69*85*10 TB | | 69 | 85 | | 10 | |
| FSH0219NB | 69*85*10 TC | | 69 | 85 | | 10 | |
| FSH0437NB | 70*85*6 SC | | 70 | 85 | | 6 | |
| FSH0413NB | 70*85*7 SC | | 70 | 85 | | 7 | |
| FSH0821FB | 70*85*7 TC(VITON) | | 70 | 85 | | 7 | |
| FSH0244NB | 70*85*8 SC | | 70 | 85 | | 8 | |
| FSH0244FB | 70*85*8 SC(VITON) | | 70 | 85 | | 8 | |
| FSH0097NB | 70*85*8 TB | | 70 | 85 | | 8 | |
| FSH0151QB | 70*85*8 TB (VMQ) | (SILICON) | 70 | 85 | | 8 | |
| FSH0133NB | 70*85*8 TC | | 70 | 85 | | 8 | |
| FSH0133QB | 70*85*8 TC (VMQ) | | 70 | 85 | | 8 | |
| FSH0133FB | 70*85*8 TC(VITON) | | 70 | 85 | | 8 | |
| FSH0840FB | 70*85*8/8.5 TCV(VITON) | | 70 | 85 | | 8 | 8.5 |
| FSH0098NB | 70*85*9 SB | | 70 | 85 | | 9 | |
| FSH0235NB | 70*85*10 TC | | 70 | 85 | | 10 | |
| FSH0235FB | 70*85*10 TC(VITON) | | 70 | 85 | | 10 | |
| FSH0307NB | 70*85*12 TC(BROWN) | | 70 | 85 | | 12 | |
| FSH0804NB | 75*85*6 TC | | 75 | 85 | | 6 | |
| FSH0306NB | 75*85*7/10 GA | | 75 | 85 | | 7 | 10 |
| FSH0332NB | 75*85*10 TC | | 75 | 85 | | 10 | |
| FSD9895NB | 58.75*85.1*7.95 TC | | 58.75 | 85.1 | | 7.95 | |
| FSH0093NB | 66.68*85.21*11.91 SA | 2.625*3.355*0.469 SA | 66.68 | 85.21 | | 11.91 | |
| FSH0113NB | 66.55*85.24*11.94 SB | 2.620*3.356*0.470 SB | 66.55 | 85.24 | | 11.94 | |
| FSH0209NB | 57.15*85.59*12.7 TC | 2.250*3.370*0.500 TC | 57.15 | 85.59 | | 12.7 | |
| FSH9947NB | 66.68*85.59*12.7 TA | | 66.68 | 85.59 | | 12.7 | |

| WLK CODE | OIL SEALS | DESCRIPTION | ID | OD1 | OD2 | H1 | H2 |
|-----------|--------------------------|--------------------------|--------|--------|------|-------|------|
| FSH0210NB | 57.15*85.6*9.5 TC | 2.250*3.370*0.374 TC | 57.15 | 85.6 | | 9.5 | |
| FSH0031NB | 53.98*85.62*7.92 KBI | 2.125*3.371*0.312 KBI | 53.98 | 85.62 | | 7.92 | |
| FSH9993NB | 57.15*85.62*9.52 VC | | 57.15 | 85.62 | | 9.52 | |
| FSH9991QB | 66.7*85.7*9.5 HSGL(VMQ) | BROWN(VMQ) | 66.7 | 85.7 | | 9.5 | |
| FSH9920NB | 57.15*85.72*9.53 TA | | 57.15 | 85.72 | | 9.53 | |
| FSH9957NB | 57.15*85.72*9.53 TB | | 57.15 | 85.72 | | 9.53 | |
| FSH9921NB | 63.5*85.72*12.7 TC | | 63.5 | 85.72 | | 12.7 | |
| FSH0056NB | 50.8*85.725*11.43 TA2 | 2.000*3.370*0.450 TA2 | 50.8 | 85.725 | | 11.43 | |
| FSH0247NB | 57.15*85.725*12.7 TC | 2.250*3.375*0.500 TC | 57.15 | 85.725 | | 12.7 | |
| FSH9931NB | 60.325*85.725*12.7 SC | 2.375*3.375*0.5 SC無商標 | 60.325 | 85.725 | | 12.7 | |
| FSH0234NB | 60.325*85.725*12.7 TC | 2.375*3.375*0.5 TC | 60.325 | 85.725 | | 12.7 | |
| FSH9946NB | 50.8*85.73*12.7 TC | | 50.8 | 85.73 | | 12.7 | |
| FSH9937NB | 53.97*85.73*9.53 TC | | 53.97 | 85.73 | | 9.53 | |
| FSH0815NB | 57.15*85.73*9.52 TC | | 57.15 | 85.73 | | 9.52 | |
| FSH9996NB | 57.15*85.73*9.53 VC | 2.250*3.375*0.375 VC | 57.15 | 85.73 | | 9.53 | |
| FSG9989NB | 57.15*85.73*12.7 TB | | 57.15 | 85.73 | | 12.7 | |
| FSG0291NB | 57.15*85.73*12.7 TC | | 57.15 | 85.73 | | 12.7 | |
| FSG9891NB | 60.33*85.73*12.7 TA | | 60.33 | 85.73 | | 12.7 | |
| FSG9852NB | 60.33*85.73*12.7 TC | | 60.33 | 85.73 | | 12.7 | |
| FSG9866NB | 60.33*85.73*22.23 TA4 | NBR咖啡色+紅漆無商標 | 60.33 | 85.73 | | 22.23 | |
| FSH9965NB | 63.5*85.73*9.53 TC | | 63.5 | 85.73 | | 9.53 | |
| FSG9881NB | 65.1*85.73*9.53 SC | | 65.1 | 85.73 | | 9.53 | |
| FSH9964NB | 66.68*85.73*9.53 TA | | 66.68 | 85.73 | | 9.53 | |
| FSH9934NB | 66.68*85.73*9.53 TB | | 66.68 | 85.73 | | 9.53 | |
| FSH0092NB | 66*85.85*10 HSC | | 66 | 85.85 | | 10 | |
| FSH0070NB | 58.04*85.98*11.94 SC | 2.285*3.385*0.470 SC | 58.04 | 85.98 | | 11.94 | |
| FSH0400NB | 57*86*13 TC | | 57 | 86 | | 13 | |
| FSH0262NB | 60*86*7/12.5 TB9 | MB-633432 | 60 | 86 | | 7 | 12.5 |
| FSH0021NB | 60*86*13 SC | | 60 | 86 | | 13 | |
| FSG0298NB | 65*86*8 TC | | 65 | 86 | | 8 | |
| FSH0403NB | 65*86*10 TC | | 65 | 86 | | 10 | |
| FSH0240NB | 68*86*8 HTCL | 09283-68001 | 68 | 86 | | 8 | |
| FSH0240QB | 68*86*8 HTCL(VMQ) | | 68 | 86 | | 8 | |
| FSH0096NB | 68*86*8 TC | | 68 | 86 | | 8 | |
| FSH0366NB | 69*86/99.5/101*7/15 DB5Y | FOR PRADO 90316-69001 | 69 | 86 | 99.5 | 7 | 15 |
| FSH0845NB | 70*86*10 TB | | 70 | 86 | | 10 | |
| FSH0358NB | 72*86*7 TC | | 72 | 86 | | 7 | |
| FSH0032NB | 74.5*86*13 (IE29) | | 74.5 | 86 | | 13 | |
| FSH0028NB | 58*87*7 XMH(OVC) | | 58 | 87 | | 7 | |
| FSH0252NB | 68*87*8 TC | | 68 | 87 | | 8 | |
| FSH0285NB | 70*87*8.5 HTCL | 90677-0013;80677-0011/12 | 70 | 87 | | 8.5 | |
| FSH0099NB | 70*87*10 HTCL | | 70 | 87 | | 10 | |
| FSH0101NB | 70*87*10 HTCR | | 70 | 87 | | 10 | |
| FSH0100NB | 70*87*10 TC | | 70 | 87 | | 10 | |
| FSH0020NB | 53*88*8.5 TC | | 53 | 88 | | 8.5 | |
| FSH0836NB | 55*88*10 SC | | 55 | 88 | | 10 | |
| FSH0417NB | 55*88*10 TC | | 55 | 88 | | 10 | |
| FSH0281NB | 55*88*12 TC(BROWN) | | 55 | 88 | | 12 | |
| FSH0337NB | 60*88*12 TC | | 60 | 88 | | 12 | |
| FSH0361NB | 62*88*12 TC | | 62 | 88 | | 12 | |
| FSH0250NB | 63*88*10 TC | | 63 | 88 | | 10 | |
| FSH0402NB | 63*88*12 TC | | 63 | 88 | | 12 | |
| FSH0823NB | 64*88*8 TC | | 64 | 88 | | 8 | |
| FSH0329NB | 64*88*13/19 TCY | | 64 | 88 | | 13 | 19 |
| FSH0089NB | 65*88*8.5 TC | | 65 | 88 | | 8.5 | |
| FSH0345NB | 65*88*9/18 KB9 | | 65 | 88 | | 9 | 18 |
| FSH0158NB | 65*88*9/18 TAY | 40227-C8200,NJ880 | 65 | 88 | | 9 | 18 |

| WLK CODE | OIL SEALS | DESCRIPTION | ID | OD1 | OD2 | H1 | H2 |
|-----------|--|---------------------------|-------|------|-----|-------|-------|
| FSH0291NB | 65*88*10 TC | | 65 | 88 | | 10 | |
| FSH0439NB | 65*88*10/15.7 TB9 | | 65 | 88 | | 10 | 15.7 |
| FSH0355NB | 65*88*11/16.5 KC9 | 40227-C6000 | 65 | 88 | | 11 | 16.5 |
| FSH0019NB | 65*88*12 SC | 2T FRONT | 65 | 88 | | 12 | |
| FSH0035NB | 65*88*12 TC | 2T 曲軸 2T/3T | 65 | 88 | | 12 | |
| FSH0035FB | 65*88*12 TC (FKM) | | 65 | 88 | | 12 | |
| FSH0091NB | 65*88*12/19 HTC9R | 9828-65116 | 65 | 88 | | 12 | 19 |
| FSH0303NB | 68*88*8 TC | | 68 | 88 | | 8 | |
| FSH0277NB | 68*88*10 TA | 90043-11102 | 68 | 88 | | 10 | |
| FSH0282NB | 68*88*10 TC | | 68 | 88 | | 10 | |
| FSH0313NB | 68*88*12 TC | | 68 | 88 | | 12 | |
| FSH0225NB | 70*88*8 TC | 12278-97000 | 70 | 88 | | 8 | |
| FSH0225FB | 70*88*8 TC(VITON) | | 70 | 88 | | 8 | |
| FSH0225QB | 70*88*8 TC(VMQ) | | 70 | 88 | | 8 | |
| FSH0255NB | 70*88*10 TC | | 70 | 88 | | 10 | |
| FSH0026NB | 70*88*12 HTCL | 0370-11-399 | 70 | 88 | | 12 | |
| FSH0026QB | 70*88*12 HTCL(VMQ) | | 70 | 88 | | 12 | |
| FSH0200NB | 70*88*12 TB | 32136-90062 | 70 | 88 | | 12 | |
| FSH0018NB | 70*88*12 TC | 32136-90007,0370-11-399 | 70 | 88 | | 12 | |
| FSH0431NB | 71*88*8 TC | | 71 | 88 | | 8 | |
| FSH0309NB | 72*88*8 TC | | 72 | 88 | | 8 | |
| FSH0426NB | 74*88*8 TC | | 74 | 88 | | 8 | |
| FSH0797NB | 50.8*88.9*12.7 SC | | 50.8 | 88.9 | | 12.7 | |
| FSH9990NB | 57.15*88.9*9.53 TA | | 57.15 | 88.9 | | 9.53 | |
| FSH9982NB | 57.15*88.9*11.13 SA | 2.25*3.50*0.438 | 57.15 | 88.9 | | 11.13 | |
| FSH9951NB | 57.15*88.9*12.7 TC | | 57.15 | 88.9 | | 12.7 | |
| FSH9966NB | 60.33*88.9*9.53 TA | | 60.33 | 88.9 | | 9.53 | |
| FSH9954NB | 60.33*88.9*9.53 TB | | 60.33 | 88.9 | | 9.53 | |
| FSG9968NB | 60.33*88.9*11.13 TA | | 60.33 | 88.9 | | 11.13 | |
| FSG9890NB | 60.33*88.9*12.7 TC | | 60.33 | 88.9 | | 12.7 | |
| FSH9935NB | 63.5*88.9*7.95 TB | | 63.5 | 88.9 | | 7.95 | |
| FSH9987NB | 63.5*88.9*9.53 TC | | 63.5 | 88.9 | | 9.53 | |
| FSH9925NB | 63.5*88.9*11.29 TB | | 63.5 | 88.9 | | 11.29 | |
| FSH9980NB | 63.5*88.9*12.7 SC | 2.500*3.500*0.500 SC | 63.5 | 88.9 | | 12.7 | |
| FSH9929NB | 63.5*88.9*12.7 TA | | 63.5 | 88.9 | | 12.7 | |
| FSH0205NB | 63.5*88.9*12.7 TB | | 63.5 | 88.9 | | 12.7 | |
| FSH0114NB | 63.5*88.9*12.7 TB3 | 2.500*3.500*0.500 TB3 | 63.5 | 88.9 | | 12.7 | |
| FSH0125NB | 63.5*88.9*12.7 TC | 2.500*3.500*0.500 TC | 63.5 | 88.9 | | 12.7 | |
| FSH0125FB | 63.5*88.9*12.7 TC(VITON) | 2.500*3.500*0.500 TC(FKM) | 63.5 | 88.9 | | 12.7 | |
| FSH9979NB | 66.67*88.9*12.7 SC | | 66.67 | 88.9 | | 12.7 | |
| FSH9971NB | 66.68*88.9*9.53 TA | | 66.68 | 88.9 | | 9.53 | |
| FSH9933NB | 66.68*88.9*9.53 TC | | 66.68 | 88.9 | | 9.53 | |
| FSH9986NB | 66.68*88.9*12.7 TC | 2.625*3.500*0.500 | 66.68 | 88.9 | | 12.7 | |
| FSH9945NB | 68.28*88.9*9.53 TC | | 68.28 | 88.9 | | 9.53 | |
| FSH9927NB | 69.85*88.9*6.35 SC | | 69.85 | 88.9 | | 6.35 | |
| FSH9949NB | 69.85*88.9*6.35 VBP Green Painting | #27271 NBR80度 | 69.85 | 88.9 | | 6.35 | |
| FSH9952NB | 69.85*88.9*9.52 SC | | 69.85 | 88.9 | | 9.52 | |
| FSH9983NB | 69.85*88.9*9.53 TA | | 69.85 | 88.9 | | 9.53 | |
| FSH9948NB | 69.85*88.9*9.53 TB | | 69.85 | 88.9 | | 9.53 | |
| FSH9985NB | 69.85*88.9*9.53 TC | | 69.85 | 88.9 | | 9.53 | |
| FSH9970NB | 69.85*88.9*12.7 TC | | 69.85 | 88.9 | | 12.7 | |
| FSH9963NB | 73.02*88.9*8.33/11.91 SZ9 GREEN PAINTING | | 73.02 | 88.9 | | 8.33 | 11.91 |
| FSH0819NB | 62*89*12 TC | | 62 | 89 | | 12 | |
| FSH0365NB | 65*89*10 TC | | 65 | 89 | | 10 | |
| FSH0340NB | 73*89*8.5 HTCL BROWN | BH6133F | 73 | 89 | | 8.5 | |
| FSH0340QB | 73*89*8.5 HTCL(VMQ) | BH6133F | 73 | 89 | | 8.5 | |
| FSH0348NB | 73.5*89*8.5 HTCL(BROWN) | 90043-11292-000 | 73.5 | 89 | | 8.5 | |

| WLK CODE | OIL SEALS | DESCRIPTION | ID | OD1 | OD2 | H1 | H2 |
|-----------|----------------------------------|--------------------------|-------|-------|-----|-------|------|
| FSH0829NB | 75*89*4/7 SCS-1 | | 75 | 89 | | 4 | 7 |
| FSI0108PB | 79*89*2.5 PTFE | D3NN485A | 79 | 89 | | 2.5 | |
| FSH0119NB | 63.5*89.02*12.7 TC D401 | 2.500*3.500*0.500 TC | 63.5 | 89.02 | | 12.7 | |
| FSH0830NB | 66.67*89.3*10 HTGR | | 66.67 | 89.3 | | 10 | |
| FSH9999NB | 66.68*89.31*9.53 HTGR NBR RED | | 66.68 | 89.31 | | 9.53 | |
| FSH9999QB | 66.68*89.31*9.53 HTGR VMQ | 2.625*3.516*0.375 HTGR | 66.68 | 89.31 | | 9.53 | |
| FSH9959NB | 73*89.5/98*7/15.8 DBG5Y | TOYOTA HI-LUX 2KD/5L/VIG | 73 | 89.5 | 98 | 7 | 15.8 |
| FSH9930NB | 69.85*89.99*10.31 HSGL | | 69.85 | 89.99 | | 10.31 | |
| FSH9975NB | 69.85*89.99*12.7 TA Red Painting | 2.75*3.543*0.500 TA | 69.85 | 89.99 | | 12.7 | |
| FSH0798NB | 38*90*8 TC | | 38 | 90 | | 8 | |
| FSH0269NB | 40*90*8 TC | | 40 | 90 | | 8 | |
| FSH0352NB | 40*90*9 TC | | 40 | 90 | | 9 | |
| FSH0012NB | 40*90*10 SC | | 40 | 90 | | 10 | |
| FSH0341NB | 40*90*10 TC | | 40 | 90 | | 10 | |
| FSH0341FB | 40*90*10 TC(VITON) | | 40 | 90 | | 10 | |
| FSH0102NB | 40*90*12 TC | | 40 | 90 | | 12 | |
| FSH0806NB | 44*90*10 TB | | 44 | 90 | | 10 | |
| FSH0154NB | 45*90*10 TC | | 45 | 90 | | 10 | |
| FSH0383NB | 47*90*8 TC | | 47 | 90 | | 8 | |
| FSH0288NB | 48*90*8 SB | | 48 | 90 | | 8 | |
| FSH0846NB | 48*90*10 SB | | 48 | 90 | | 10 | |
| FSH0396NB | 48*90*10 TC | | 48 | 90 | | 10 | |
| FSH0410NB | 48*90*13 TC | | 48 | 90 | | 13 | |
| FSH0795NB | 50*90*8 TC | | 50 | 90 | | 8 | |
| FSH0103FB | 50*90*10 SC(VITON) | | 50 | 90 | | 10 | |
| FSH0387NB | 50*90*10 TA | | 50 | 90 | | 10 | |
| FSH0104NB | 50*90*10 TB | | 50 | 90 | | 10 | |
| FSH0010NB | 50*90*10 TC | | 50 | 90 | | 10 | |
| FSH0010FB | 50*90*10 TC(VITON) | | 50 | 90 | | 10 | |
| FSH0388NB | 50*90*12 TA | | 50 | 90 | | 12 | |
| FSH0301NB | 50*90*12 TC | | 50 | 90 | | 12 | |
| FSH0034NB | 50*90/98*12.7/14.5 TCFY | 50*90*14.3 TCFY | 50 | 90 | 98 | 12.7 | 14.5 |
| FSH0258NB | 50*90*13 SC | | 50 | 90 | | 13 | |
| FSH0330NB | 50*90*13 TB | | 50 | 90 | | 13 | |
| FSH0411NB | 50*90*13 TC | | 50 | 90 | | 13 | |
| FSH0428NB | 52*90*10 TC | | 52 | 90 | | 10 | |
| FSH0316NB | 54*90*13 SC | | 54 | 90 | | 13 | |
| FSH0152N0 | 55*90*6 VB | | 55 | 90 | | 6 | |
| FSH0231NB | 55*90*8 TC | | 55 | 90 | | 8 | |
| FSH0231FB | 55*90*8 TC(VITON) | | 55 | 90 | | 8 | |
| FSH0803FB | 55*90*10 SC(VITON) | | 55 | 90 | | 10 | |
| FSH0105NB | 55*90*10 TC | | 55 | 90 | | 10 | |
| FSH0105FB | 55*90*10 TC(VITON) | | 55 | 90 | | 10 | |
| FSH0822NB | 55*90*12 TC | | 55 | 90 | | 12 | |
| FSH0831NB | 55*90*13 TB | | 55 | 90 | | 13 | |
| FSH0259NB | 55*90*13 TC | | 55 | 90 | | 13 | |
| FSH0382NB | 56*90*10 TC | | 56 | 90 | | 10 | |
| FSH0796NB | 57*90*13 TC | | 57 | 90 | | 13 | |
| FSH0808NB | 58*90*8 TC | | 58 | 90 | | 8 | |
| FSH0146NB | 58*90*10 TC | | 58 | 90 | | 10 | |
| FSH0009NB | 58*90*11 SCY | 2T R. GEAR SHAFT | 58 | 90 | | 11 | |
| FSH0106NB | 58*90*12 TC | | 58 | 90 | | 12 | |
| FSH0391NB | 58*90*13 SA | | 58 | 90 | | 13 | |
| FSH0351NB | 58*90*13 SC | | 58 | 90 | | 13 | |
| FSH0440NB | 58*90*13 TC | | 58 | 90 | | 13 | |
| FSH0289NB | 60*90*8 SC | | 60 | 90 | | 8 | |
| FSH0270NB | 60*90*8 TC | | 60 | 90 | | 8 | |

| WLK CODE | OIL SEALS | DESCRIPTION | ID | OD1 | OD2 | H1 | H2 |
|-----------|-----------------------------------|-----------------|------|-----|-----|----|------|
| FSH0270FB | 60*90*8 TC(VITON)FKM | | 60 | 90 | | 8 | |
| FSH0273NB | 60*90*10 TB | | 60 | 90 | | 10 | |
| FSH0107NB | 60*90*10 TC | | 60 | 90 | | 10 | |
| FSH0107FB | 60*90*10 TC(VITON) | | 60 | 90 | | 10 | |
| FSH0008NB | 60*90*11 TC | YANMER 24HP曲軸 | 60 | 90 | | 11 | |
| FSH0008FB | 60*90*11 TC(VITON) | | 60 | 90 | | 11 | |
| FSH0809NB | 60*90*12 SB | | 60 | 90 | | 12 | |
| FSH0274NB | 60*90*12 TB | | 60 | 90 | | 12 | |
| FSH0007NB | 60*90*12 TC | 2T THRUST SHAFT | 60 | 90 | | 12 | |
| FSH0007FB | 60*90*12 TC(VITON) | | 60 | 90 | | 12 | |
| FSH0279NB | 60*90*13 TA | | 60 | 90 | | 13 | |
| FSH0260NB | 60*90*13 TC | | 60 | 90 | | 13 | |
| FSH0260QB | 60*90*13 TC(VMQ) | | 60 | 90 | | 13 | |
| FSH0376NB | 60*90*18/22 YDS-S | 40227-41W03 | 60 | 90 | | 18 | 22 |
| FSH0144NB | 62*90*10 TC | | 62 | 90 | | 10 | |
| FSH0144FB | 62*90*10 TC(VITON) | | 62 | 90 | | 10 | |
| FSH0434NB | 62*90*12 SA | | 62 | 90 | | 12 | |
| FSH0290NB | 62*90*12 TC | | 62 | 90 | | 12 | |
| FSH0290FB | 62*90*12 TC(VITON) | | 62 | 90 | | 12 | |
| FSH0825NB | 62*90*12/16 TCY | | 62 | 90 | | 12 | 16 |
| FSH0421NB | 62*90*13 SC | | 62 | 90 | | 13 | |
| FSH0414NB | 62*90*13 TC | | 62 | 90 | | 13 | |
| FSH0242NB | 63*90*7/10 TB9 | 90311-63001 | 63 | 90 | | 7 | 10 |
| FSH0254NB | 63*90*8 TC | | 63 | 90 | | 8 | |
| FSH0251NB | 63*90*10 TC | | 63 | 90 | | 10 | |
| FSH0838NB | 63.5*90*13 SC | | 63.5 | 90 | | 13 | |
| FSH0298NB | 64*90*10 SA | | 64 | 90 | | 10 | |
| FSH0810NB | 64*90*12 TB | | 64 | 90 | | 12 | |
| FSH0317NB | 64*90*13 TB | | 64 | 90 | | 13 | |
| FSH0327NB | 64*90*13 TC | | 64 | 90 | | 13 | |
| FSH0799NB | 65*90*7 TC | | 65 | 90 | | 7 | |
| FSH0799FB | 65*90*7 TC(VITON) | | 65 | 90 | | 7 | |
| FSH0302NB | 65*90*8 TC | | 65 | 90 | | 8 | |
| FSH0302FB | 65*90*8 TC(VITON) | | 65 | 90 | | 8 | |
| FSH0339NB | 65*90*10 TB | | 65 | 90 | | 10 | |
| FSH0108NB | 65*90*10 TC | | 65 | 90 | | 10 | |
| FSH0108FB | 65*90*10 TC(VITON) | | 65 | 90 | | 10 | |
| FSH0108QB | 65*90*10 TC(VMQ) | | 65 | 90 | | 10 | |
| FSH0375FB | 65*90*10/10.5 TCV(VITON) | | 65 | 90 | | 10 | 10.5 |
| FSH0362NB | 65*90/97*11 DB5Y w/NYLON | 43232-11G00 | 65 | 90 | 97 | 11 | |
| FSH0378NB | 65*90*12 TB | | 65 | 90 | | 12 | |
| FSH0140NB | 65*90*12 TC | | 65 | 90 | | 12 | |
| FSH0140FB | 65*90*12 TC(VITON) | | 65 | 90 | | 12 | |
| FSH0014NB | 65*90*12/14 TCY | | 65 | 90 | | 12 | 14 |
| FSH0006NB | 65*90*13 TB | W001-33-065 | 65 | 90 | | 13 | |
| FSH0016NB | 65*90*13 TC | | 65 | 90 | | 13 | |
| FSH0016QB | 65*90*13 TC (VMQ) | | 65 | 90 | | 13 | |
| FSH0016FB | 65*90*13 TC(VITON) | | 65 | 90 | | 13 | |
| FSH0384NB | 65*90*13 TCN | | 65 | 90 | | 13 | |
| FSH0424NB | 65*90*15 HSB2(Brown NBR+Painting) | | 65 | 90 | | 15 | |
| FSH0833NB | 67*90/100*12/19.5 TB5Y | | 67 | 90 | 100 | 12 | 19.5 |
| FSH0331NB | 68*90*8 SB | | 68 | 90 | | 8 | |
| FSH0442NB | 68*90*8 TC | | 68 | 90 | | 8 | |
| FSH0211NB | 68*90*10 SC | | 68 | 90 | | 10 | |
| FSH0109NB | 68*90*10 TA2 | 90311-68001 | 68 | 90 | | 10 | |
| FSH0441NB | 68*90*10 TB | | 68 | 90 | | 10 | |
| FSH0015NB | 68*90*10 TC | | 68 | 90 | | 10 | |

| WLK CODE | OIL SEALS | DESCRIPTION | ID | OD1 | OD2 | H1 | H2 |
|-----------|----------------------------|---------------|----|-----|-----|-----|-----|
| FSH0015FB | 68*90*10 TC(VITON) | | 68 | 90 | | 10 | |
| FSH0438NB | 68*90*10/18 HTBL | | 68 | 90 | | 10 | 18 |
| FSH0005NB | 68*90*12 TB(TBP) | 9-09924-338-0 | 68 | 90 | | 12 | |
| FSH0004NB | 68*90*12 TC | NT110/N15Y 曲軸 | 68 | 90 | | 12 | |
| FSH0110NB | 68*90*13 TB | MT-119305 | 68 | 90 | | 13 | |
| FSH0203NB | 68*90*13 TC | | 68 | 90 | | 13 | |
| FSH0203QB | 68*90*13 TC(VMQ) | | 68 | 90 | | 13 | |
| FSH0363NB | 68*90*13 TCN(NBR85 Shore) | | 68 | 90 | | 13 | |
| FSH0844NB | 69*90*10 TC | | 69 | 90 | | 10 | |
| FSH0003NB | 70*90*6 HSCL | | 70 | 90 | | 6 | |
| FSH0149NB | 70*90*7 TC | | 70 | 90 | | 7 | |
| FSH0149FB | 70*90*7 TC(FKM) | VITON | 70 | 90 | | 7 | |
| FSH0295NB | 70*90*7 TCV(NBR Blue 80) | | 70 | 90 | | 7 | |
| FSH0436NB | 70*90*7/7.5 TCV | | 70 | 90 | | 7 | 7.5 |
| FSH0319NB | 70*90*8 TC | | 70 | 90 | | 8 | |
| FSH0319FB | 70*90*8 TC(VITON) | | 70 | 90 | | 8 | |
| FSH0002NB | 70*90*10 HSC(L) | | 70 | 90 | | 10 | |
| FSH0002QB | 70*90*10 HSCL (VMQ) | 113 105 245FS | 70 | 90 | | 10 | |
| FSH0013NB | 70*90*10 HTBL | | 70 | 90 | | 10 | |
| FSH0817NB | 70*90*10 SB | | 70 | 90 | | 10 | |
| FSH0418NB | 70*90*10 SC | | 70 | 90 | | 10 | |
| FSH0418FB | 70*90*10 SC(VITON) | TC型修掉副唇 | 70 | 90 | | 10 | |
| FSH0256NB | 70*90*10 TA2 | 5-09625-029 | 70 | 90 | | 10 | |
| FSH0805NB | 70*90*10 TB | | 70 | 90 | | 10 | |
| FSH0111NB | 70*90*10 TC | | 70 | 90 | | 10 | |
| FSH0111FB | 70*90*10 TC (FKM)VITON | | 70 | 90 | | 10 | |
| FSH0824NB | 70*90*12 TB | | 70 | 90 | | 12 | |
| FSH0001NB | 70*90*12 TC | | 70 | 90 | | 12 | |
| FSH0001FB | 70*90*12 TC(VITON) | | 70 | 90 | | 12 | |
| FSH0842NB | 70*90*12 TCV | | 70 | 90 | | 12 | |
| FSH0272FB | 70*90*13 SC (FKM) | | 70 | 90 | | 13 | |
| FSH0286NB | 70*90*13 TC | | 70 | 90 | | 13 | |
| FSH0286FB | 70*90*13 TC(VITON)75 Shore | | 70 | 90 | | 13 | |
| FSH0286QB | 70*90*13 TC(VMQ) | | 70 | 90 | | 13 | |
| FSH0336NB | 70*90*13 TZ | | 70 | 90 | | 13 | |
| FSI1004NB | 72*90*8 SC | | 72 | 90 | | 8 | |
| FSI0131NB | 72*90*10 SC | | 72 | 90 | | 10 | |
| FSH0334NB | 72*90*10 TA | | 72 | 90 | | 10 | |
| FSH0372NB | 72*90*10 TB | | 72 | 90 | | 10 | |
| FSI0111NB | 72*90*10 TC | | 72 | 90 | | 10 | |
| FSI0208NB | 72*90*12 TC | | 72 | 90 | | 12 | |
| FSH0404NB | 72*90*13 TC | | 72 | 90 | | 13 | |
| FSI0265NB | 73*90*7 TC | | 73 | 90 | | 7 | |
| FSI0097NB | 73*90*7.5 TB(TZ) | 8-94248-117-1 | 73 | 90 | | 7.5 | |
| FSH0232NB | 73*90*8 TB(TZ) | | 73 | 90 | | 8 | |
| FSH0392NB | 73*90*8 TBP | | 73 | 90 | | 8 | |
| FSH0357NB | 74*90*8 TC | | 74 | 90 | | 8 | |
| FSH0326NB | 74*90*10 HSBR | | 74 | 90 | | 10 | |
| FSH0818NB | 74*90*10 TB | | 74 | 90 | | 10 | |
| FSH0323NB | 74*90*10 TC | | 74 | 90 | | 10 | |
| FSH0420NB | 75*90*7 TC | | 75 | 90 | | 7 | |
| FSH0377NB | 75*90*8 SC | | 75 | 90 | | 8 | |
| FSH0236NB | 75*90*8 TC | | 75 | 90 | | 8 | |
| FSH0236FB | 75*90*8 TC(VITON) | | 75 | 90 | | 8 | |
| FSH0117NB | 75*90*10 TC | | 75 | 90 | | 10 | |
| FSH0117FB | 75*90*10 TC(VITON) | | 75 | 90 | | 10 | |

| WLK CODE | OIL SEALS | DESCRIPTION | ID | OD1 | OD2 | H1 | H2 |
|-----------|---------------------------|--------------------------|-------|-------|-----|-------|------|
| FSH0198NB | 75*90*12 TC | | 75 | 90 | | 12 | |
| FSH0346NB | 75*90*13 TB | | 75 | 90 | | 13 | |
| FSH0385NB | 75*90*13 TC | | 75 | 90 | | 13 | |
| FSH0405NB | 76*90*10 SC | | 76 | 90 | | 10 | |
| FSH0367NB | 77*90*10 HTCKL W/Felt | | 77 | 90 | | 10 | |
| FSH0344NB | 77*90*10 TC | | 77 | 90 | | 10 | |
| FSH0300N0 | 80*90*7/10 GA(似DKI) | | 80 | 90 | | 7 | 10 |
| FSH0406NB | 80*90*10 TC | | 80 | 90 | | 10 | |
| FSI0233N0 | 80*90/96*10/18 VBC59Y | TOYOTA HI-LUX 2KD/5L/VIG | 80 | 90 | 96 | 10 | 18 |
| FSL0006N0 | 125*90*12 X3 | | 125 | 90 | | 12 | |
| PML0006C | 125*90*12 X3 (鐵殼) | WEAR RING | 125 | 90 | | 12 | |
| FSH0197NO | 62.84*90.02*7.24 UM | 2.474*3.544*0.285 UM | 62.84 | 90.02 | | 7.24 | |
| FSH9978NB | 60.33*90.09*9.53 TA | | 60.33 | 90.09 | | 9.53 | |
| FSI9955NB | 63.5*90.09*12.7 TC | | 63.5 | 90.09 | | 12.7 | |
| FSI0189NB | 77.5*91/96*6.2/10.9 TB59 | 40227-0T000 | 77.5 | 91 | 96 | 6.2 | 10.9 |
| FSI0175NB | 60*91.5*10 TC | | 60 | 91.5 | | 10 | |
| FSI0029NB | 69.85*91.95*14.48 TB | 2.750*3.620*0.570 TB | 69.85 | 91.95 | | 14.48 | |
| FSI0277NB | 44*92*10 TB | | 44 | 92 | | 10 | |
| FSI0301NB | 49*92*10 TC | | 49 | 92 | | 10 | |
| FSI0306NB | 60*92*11 SC | | 60 | 92 | | 11 | |
| FSH0312NB | 62*92*11 TC(BROWN) | | 62 | 92 | | 11 | |
| FSI0314NB | 62*92*12 TC | | 62 | 92 | | 12 | |
| FSI0200NB | 65*92*10 TC | | 65 | 92 | | 10 | |
| FSI0158NB | 65*92*12 SC | | 65 | 92 | | 12 | |
| FSI0155NB | 65*92*12 TB | 1-09625-0520 | 65 | 92 | | 12 | |
| FSI0236NB | 65*92*12 TC | | 65 | 92 | | 12 | |
| FSI0310NB | 65*92*13 TA | | 65 | 92 | | 13 | |
| FSI0143NB | 65*92*13 TB | 1-09625-052-0 | 65 | 92 | | 13 | |
| FSI0135NB | 65*92*13 TC | | 65 | 92 | | 13 | |
| FSI0178NB | 68*92*10 TA | 90311-68002 | 68 | 92 | | 10 | |
| FSI0144NB | 68*92*10 TC | | 68 | 92 | | 10 | |
| FSI0243NB | 68*92*12 TB | | 68 | 92 | | 12 | |
| FSI0074NB | 69*92*12 TC | | 69 | 92 | | 12 | |
| FSI0032NB | 70*92*8.5 HTCL | 90311-70004 | 70 | 92 | | 8.5 | |
| FSI0032QB | 70*92*8.5 HTCL (VMQ) | | 70 | 92 | | 8.5 | |
| FSI1008NB | 70*92*9 TC | | 70 | 92 | | 9 | |
| FSI0112NB | 70*92*10 TC | | 70 | 92 | | 10 | |
| FSI0220NB | 70*92*10/16 HTC9R | | 70 | 92 | | 10 | 16 |
| FSI0033NB | 70*92*12 HTCL | 90311-70001/03/75 | 70 | 92 | | 12 | |
| FSI0033QB | 70*92*12 HTCL (VMQ) | 90311-70001 | 70 | 92 | | 12 | |
| FSI0285NB | 70*92*12 TB | | 70 | 92 | | 12 | |
| FSI0012NB | 70*92*12 TC | 44414-58181 / 03434-0700 | 70 | 92 | | 12 | |
| FSI0262NB | 72*92*10 TC | | 72 | 92 | | 10 | |
| FSI0025NB | 72*92*12 TC | | 72 | 92 | | 12 | |
| FSI0253NB | 75*92*12 TC | | 75 | 92 | | 12 | |
| FSI0270NB | 76*92*10 TC | | 76 | 92 | | 10 | |
| FSI0270QB | 76*92*10 TC(VMQ) | | 76 | 92 | | 10 | |
| FSI9959NB | 66.7*92.02*11.9 TB | | 66.7 | 92.02 | | 11.9 | |
| FSI9980NB | 57.15*92.07*11.13 SA | | 57.15 | 92.07 | | 11.13 | |
| FSG9897NB | 60.33*92.07*11.13 SA | | 60.33 | 92.07 | | 11.13 | |
| FSI9949NB | 63.5*92.07*12.7 SC | | 63.5 | 92.07 | | 12.7 | |
| FSI9950FB | 63.5*92.07*12.7 TC(VITON) | | 63.5 | 92.07 | | 12.7 | |
| FSI9982NB | 66.68*92.07*9.53 TC | | 66.68 | 92.07 | | 9.53 | |
| FSI9978NB | 66.68*92.07*11.91 TB | | 66.68 | 92.07 | | 11.91 | |
| FSI9969FB | 69.85*92.07*11.13 TC(FKM) | VITON | 69.85 | 92.07 | | 11.13 | |
| FSI9967NB | 73.02*92.07*9.52 TC | 2.875*3.625*0.375 TC | 73.02 | 92.07 | | 9.52 | |
| FSI9968NB | 66.68*92.08*12.7 TC | | 66.68 | 92.08 | | 12.7 | |

| WLK CODE | OIL SEALS | DESCRIPTION | ID | OD1 | OD2 | H1 | H2 |
|------------|-------------------------|------------------------|-------|-------|-----|------|------|
| FSI0105NB | 68.66*92.08*14.30 TB | 2.703*3.625*0.563 TB | 68.66 | 92.08 | | 14.3 | |
| FSI0224NB | 45*93*5.8/7.8 SPKB | | 45 | 93 | | 5.8 | 7.8 |
| FSI0172NB | 60*93*12/15 TC6Y | | 60 | 93 | | 12 | 15 |
| FSH0359NB | 62*93*12 TC | | 62 | 93 | | 12 | |
| FSI0219NB | 65*93*8.5/18 TB9 | 8-97211-082-0 | 65 | 93 | | 8.5 | 18 |
| FSI0210NB | 74*93*10 TC Brown | | 74 | 93 | | 10 | |
| FSI0251NB | 74*93*12 TC | | 74 | 93 | | 12 | |
| FSI0194NB | 75*93*9 HTCL | | 75 | 93 | | 9 | |
| FSI0010NB | 76*93*10 TC | | 76 | 93 | | 10 | |
| FSI0011NB | 77*93*10 TB | 9-09924-241-0 | 77 | 93 | | 10 | |
| FSI0320NB | 51*94*9.6/12.3 SCY | | 51 | 94 | | 9.6 | 12.3 |
| FSI0248NB | 68*94*8 TC | | 68 | 94 | | 8 | |
| FSI0182NB | 70*94*8/10.5 TAY | 90311-70011 | 70 | 94 | | 8 | 10.5 |
| FSI0118NB | 70*94*10 TA | | 70 | 94 | | 10 | |
| FSI0280NB | 70*94*10 TB | | 70 | 94 | | 10 | |
| FSI0319NB | 72*94*8 TZ | | 72 | 94 | | 8 | |
| FSI0122NB | 72*94*10 TB | MB-025295 | 72 | 94 | | 10 | |
| FSI0145NB | 72*94*12 TC | ME-031543 | 72 | 94 | | 12 | |
| FSI0176NB | 74*94*10 TC(Brown) | | 74 | 94 | | 10 | |
| FSI0185NB | 75*94*10 HTCL (BROWN) | 12279-01B00 | 75 | 94 | | 10 | |
| FSI0207NB | 76*94*8.5 HTCL(Brown) | 90911-76001 | 76 | 94 | | 8.5 | |
| FSI0169NB | 76*94*12 TC | ME-071269 | 76 | 94 | | 12 | |
| FSI0009NB | 46*94.4*8 DSC(bore94.2) | 8-94336-315-0 | 46 | 94.4 | | 8 | |
| FSI0245NB | 40*95*10 SC | | 40 | 95 | | 10 | |
| FSI0198NB | 46*95*10/14 SC5 | MB-308934 | 46 | 95 | | 10 | 14 |
| FSI0232NB | 55*95*10 TC | | 55 | 95 | | 10 | |
| FSI0246NB | 57*95*10 SC | | 57 | 95 | | 10 | |
| FSI0217NB | 60*95*8 TC | | 60 | 95 | | 8 | |
| FSI0024NB | 60*95*10 SC | | 60 | 95 | | 10 | |
| FSI0024FB | 60*95*10 SC(VITON) | | 60 | 95 | | 10 | |
| FSI0078NB | 60*95*10 TC | | 60 | 95 | | 10 | |
| FSI0173NB | 60*95*12 TC | | 60 | 95 | | 12 | |
| FSI0116NB | 60*95*13 TC | | 60 | 95 | | 13 | |
| FSI0164NB | 62*95*10 TC | | 62 | 95 | | 10 | |
| FSI0223FB | 65*95*10 SC(FKM)VITON | | 65 | 95 | | 10 | |
| FSI0147NB | 65*95*10 TA | | 65 | 95 | | 10 | |
| FSI0081NB | 65*95*10 TC | | 65 | 95 | | 10 | |
| FSI0081FB | 65*95*10 TC(FKM)VITON | | 65 | 95 | | 10 | |
| FSI0165NB | 65*95*12 TC | | 65 | 95 | | 12 | |
| FSI0165FB | 65*95*12 TC(VITON) | | 65 | 95 | | 12 | |
| FSI0028NB | 65*95*13 TB | | 65 | 95 | | 13 | |
| FSI0082NB | 65*95*13 TC | | 65 | 95 | | 13 | |
| FSI01115NB | 65*95*14 TC | 90311-65033 | 65 | 95 | | 14 | |
| FSI0101NB | 65*95*14/22 HTB9R | 90033-11020;9828-65108 | 65 | 95 | | 14 | 22 |
| FSI0293FB | 68*95*10 SC(VITON) | | 68 | 95 | | 10 | |
| FSI0261NB | 68*95*10 TC | | 68 | 95 | | 10 | |
| FSI0216NB | 68*95*12 TC | | 68 | 95 | | 12 | |
| FSI0195QB | 68*95*13 HTCL(VMQ) | | 68 | 95 | | 13 | |
| FSI0084NB | 68*95*13 TC | | 68 | 95 | | 13 | |
| FSI0294FB | 70*95*8 TC(VITON) | | 70 | 95 | | 8 | |
| FSI0008NB | 70*95*9 TC | | 70 | 95 | | 9 | |
| FSI0123NB | 70*95*10 SC | | 70 | 95 | | 10 | |
| FSI0085NB | 70*95*10 TC | | 70 | 95 | | 10 | |
| FSI0085FB | 70*95*10 TC(VITON) | | 70 | 95 | | 10 | |
| FSI0130NB | 70*95*12 SC | | 70 | 95 | | 12 | |
| FSI0075NB | 70*95*12 TC | 38652-90000 | 70 | 95 | | 12 | |
| FSI0075FB | 70*95*12 TC(VITON)FKM | | 70 | 95 | | 12 | |

| WLK CODE | OIL SEALS | DESCRIPTION | ID | OD1 | OD2 | H1 | H2 |
|-----------|--------------------------|-------------------------|-------|-------|-----|------|----|
| FSI0302FB | 70*95*12 TG(VITON)FKM | | 70 | 95 | | 12 | |
| FSI0318NB | 70*95*13 SB | | 70 | 95 | | 13 | |
| FSI0102NB | 70*95*13 TA | | 70 | 95 | | 13 | |
| FSI0160NB | 70*95*13 TB | | 70 | 95 | | 13 | |
| FSI0007NB | 70*95*13 TC | ES 曲軸, 9828-70102 | 70 | 95 | | 13 | |
| FSI0007FB | 70*95*13 TC(VITON) | | 70 | 95 | | 13 | |
| FSI0007QB | 70*95*13 TC(VMQ) | | 70 | 95 | | 13 | |
| FSI0222NB | 70*95*13 TCN | | 70 | 95 | | 13 | |
| FSI0213NB | 70*95*13/20 HTC9R | 9828-70110, 38652-90008 | 70 | 95 | | 13 | 20 |
| FSI0240NB | 72*95*10 SC | | 72 | 95 | | 10 | |
| FSI0240FB | 72*95*10 SC(VITON) | | 72 | 95 | | 10 | |
| FSI0087NB | 72*95*10 TC | | 72 | 95 | | 10 | |
| FSI0087FB | 72*95*10 TC(VITON)FKM | | 72 | 95 | | 10 | |
| FSI0291NB | 72*95*12 SC | | 72 | 95 | | 12 | |
| FSI0181NB | 72*95*12 TC | | 72 | 95 | | 12 | |
| FSI0289NB | 72*95*13 TB | | 72 | 95 | | 13 | |
| FSI0151NB | 72*95*13 TC | | 72 | 95 | | 13 | |
| FSI0250NB | 73*95*10 SC | | 73 | 95 | | 10 | |
| FSI0109N0 | 74*95*7 VC | 43223-30100 | 74 | 95 | | 7 | |
| FSI0139NB | 74*95*10 TC | | 74 | 95 | | 10 | |
| FSI0238NB | 75*95*7 TC | | 75 | 95 | | 7 | |
| FSI0161NB | 75*95*8 SC | | 75 | 95 | | 8 | |
| FSI0141NB | 75*95*8 TC | | 75 | 95 | | 8 | |
| FSI0041NB | 75*95*10 HSCL | | 75 | 95 | | 10 | |
| FSI0041QB | 75*95*10 HSCL (VMQ) | (VMQ) | 75 | 95 | | 10 | |
| FSI0152NB | 75*95*10 HSCR | | 75 | 95 | | 10 | |
| FSI0157NB | 75*95*10 HTCR | | 75 | 95 | | 10 | |
| FSI0154NB | 75*95*10 SC | | 75 | 95 | | 10 | |
| FSI0154FB | 75*95*10 SC(VITON) | | 75 | 95 | | 10 | |
| FSI0300NB | 75*95*10 TA | | 75 | 95 | | 10 | |
| FSI0094NB | 75*95*10 TC | | 75 | 95 | | 10 | |
| FSI0094FB | 75*95*10 TC(VITON) | | 75 | 95 | | 10 | |
| FSI0283NB | 75*95*12 SA | | 75 | 95 | | 12 | |
| FSI0295FB | 75*95*12 SC(VITON) | | 75 | 95 | | 12 | |
| FSI0136NB | 75*95*12 TC | | 75 | 95 | | 12 | |
| FSI0001NB | 75*95*12 TC6 | | 75 | 95 | | 12 | |
| FSI0042NB | 75*95*13 SA | | 75 | 95 | | 13 | |
| FSI0279NB | 75*95*13 SC | | 75 | 95 | | 13 | |
| FSI0043NB | 75*95*13 TA2 | | 75 | 95 | | 13 | |
| FSI0218NB | 75*95*13 TB | | 75 | 95 | | 13 | |
| FSI0199NB | 75*95*13 TC | | 75 | 95 | | 13 | |
| FSI0199FB | 75*95*13 TC(VITON) | | 75 | 95 | | 13 | |
| FSI0006NB | 76*95*11 HTCL | | 76 | 95 | | 11 | |
| FSI0046NB | 77.7*95*11 HSGL Red(VMQ) | | 77.7 | 95 | | 11 | |
| FSI0114NB | 78*95*8 OSCY | 43213-76000 | 78 | 95 | | 8 | |
| FSI0255NB | 78*95*11 SC | | 78 | 95 | | 11 | |
| FSI1005NB | 78*95*11 TC | | 78 | 95 | | 11 | |
| FSI0304NB | 78*95*13 TB | | 78 | 95 | | 13 | |
| FSI0315NB | 80*95*5 VB | | 80 | 95 | | 5 | |
| FSI0242N0 | 80*95*5 VC | | 80 | 95 | | 5 | |
| FSI0150NB | 80*95*8 TC | | 80 | 95 | | 8 | |
| FSI0180NB | 80*95*10 TC | | 80 | 95 | | 10 | |
| FSI0180FB | 80*95*10 TC(VITON) | | 80 | 95 | | 10 | |
| FSI0004NB | 67*95.2*15.5 TC6(TC6Y) | | 67 | 95.2 | | 15.5 | |
| FSI9964NB | 57.15*95.25*12.7 TB | | 57.15 | 95.25 | | 12.7 | |
| FSI9990NB | 63.5*95.25*12.7 SC | | 63.5 | 95.25 | | 12.7 | |
| FSI9984NB | 63.5*95.25*12.7 TC | | 63.5 | 95.25 | | 12.7 | |

| WLK CODE | OIL SEALS | DESCRIPTION | ID | OD1 | OD2 | H1 | H2 |
|-----------|-----------------------------|-------------------------|-------|-------|-----|-------|----|
| FSI9974NB | 66.68*95.25*9.53 TB | | 66.68 | 95.25 | | 9.53 | |
| FSI9989NB | 66.68*95.25*9.53 TC | | 66.68 | 95.25 | | 9.53 | |
| FSI9970NB | 66.68*95.25*12.7 TA | | 66.68 | 95.25 | | 12.7 | |
| FSI9953NB | 66.68*95.25*12.7 TC | | 66.68 | 95.25 | | 12.7 | |
| FSI9995NB | 69.44*95.25*16.28 DB | 2.734*3.750*0.641 DB | 69.44 | 95.25 | | 16.28 | |
| FSI9975NB | 69.85*95.25*9.52 TC | | 69.85 | 95.25 | | 9.52 | |
| FSI9956NB | 69.85*95.25*11.13 TC | | 69.85 | 95.25 | | 11.13 | |
| FSI9960NB | 69.85*95.25*12.7 SA | | 69.85 | 95.25 | | 12.7 | |
| FSI9981NB | 69.85*95.25*12.7 TB | | 69.85 | 95.25 | | 12.7 | |
| FSI9973NB | 69.85*95.25*12.7 TC | 2.750*3.750*0.500 | 69.85 | 95.25 | | 12.7 | |
| FSI0015NB | 69.85*95.25*15.88 TC | 2.750*3.750*0.625 TC | 69.85 | 95.25 | | 15.88 | |
| FSI0040QB | 72.62*95.25*11.13 SA VMQ | 2.859*3.75*0.438 SA | 72.62 | 95.25 | | 11.13 | |
| FSI9948NB | 73.02*95.25*12.7 TA | | 73.02 | 95.25 | | 12.7 | |
| FSI9976NB | 73.02*95.25*12.7 TC | | 73.02 | 95.25 | | 12.7 | |
| FSI9963NB | 73.03*95.25*9.53 TC | | 73.03 | 95.25 | | 9.53 | |
| FSI9965NB | 74.61*95.25*9.52 HTGR Brown | | 74.61 | 95.25 | | 9.52 | |
| FSI9972NB | 74.61*95.25*9.52 SC | | 74.61 | 95.25 | | 9.52 | |
| FSI9954NB | 74.63*95.25*9.53 TC | | 74.63 | 95.25 | | 9.53 | |
| FSI9986NB | 76.2*95.25*9.53 DC | | 76.2 | 95.25 | | 9.53 | |
| FSI9987NB | 76.2*95.25*9.53 TC | | 76.2 | 95.25 | | 9.53 | |
| FSI9977NB | 76.2*95.25*11.13 TA | | 76.2 | 95.25 | | 11.13 | |
| FSI9962NB | 76.2*95.25*11.13 TB | | 76.2 | 95.25 | | 11.13 | |
| FSI9993NB | 76.2*95.25*12.7 SC | | 76.2 | 95.25 | | 12.7 | |
| FSI0049QB | 79.38*95.25*11 HTCL(VMQ) | 外徑紋路 | 79.38 | 95.25 | | 11 | |
| FSI0044NB | 76.2*95.4*12.7 SA2 | 7521391 | 76.2 | 95.4 | | 12.7 | |
| FSI0026NB | 65.28*95.5*16.26 TA | 2.570*3.760*0.640 TA | 65.28 | 95.5 | | 16.26 | |
| FSI0048QB | 79*95.5*10 HSCL (VMQ) | | 79 | 95.5 | | 10 | |
| FSI0317NB | 14*96*30 Y(NBR 60) | 3/8,WLK | 14 | 96 | | 30 | |
| FSI0316NB | 16*96*30 Y(NBR 60) | 3/6 4.0kgs WLK | 16 | 96 | | 30 | |
| FSI0171NB | 70*96*11 HTC | AH3259F | 70 | 96 | | 11 | |
| FSI0036NB | 72*96*9 HTCL | MD-008885;MD-000248 | 72 | 96 | | 9 | |
| FSI0036QB | 72*96*9 HTCL (VMQ) | | 72 | 96 | | 9 | |
| FSI0039NB | 72*96*9 HTCR | | 72 | 96 | | 9 | |
| FSI0037NB | 72*96*9 TC | | 72 | 96 | | 9 | |
| FSI0290NB | 73*96*9 TC | | 73 | 96 | | 9 | |
| FSI0252NB | 74*96*9 TC | | 74 | 96 | | 9 | |
| FSI0254NB | 75*96*11 TB | | 75 | 96 | | 11 | |
| FSI0045QB | 77*96*11 HSC (VMQ) | | 77 | 96 | | 11 | |
| FSI0050NB | 80*96*9 HTCL | MD-050604 | 80 | 96 | | 9 | |
| FSI0050AB | 80*96*9 HTCL(ACM) | | 80 | 96 | | 9 | |
| FSI0050QB | 80*96*9 HTCL(VMQ) | MD-069947/050604/020435 | 80 | 96 | | 9 | |
| FSI0051NB | 80*96*9 HTCR | | 80 | 96 | | 9 | |
| FSI0258NB | 73*97*12 HTCL | | 73 | 97 | | 12 | |
| FSI0117NB | 74*97*12 HTCL (BROWN) | | 74 | 97 | | 12 | |
| FSI0186NB | 80*97*7 TC(BROWN) | | 80 | 97 | | 7 | |
| FSI0187NB | 80*97*8 VB | | 80 | 97 | | 8 | |
| FSI0249NB | 68*98*10 TC | | 68 | 98 | | 10 | |
| FSI0275NB | 72*98*12 TC | | 72 | 98 | | 12 | |
| FSI0127NB | 74*98*12 HTCR | 91214-634-004 | 74 | 98 | | 12 | |
| FSI0140NB | 74*98*12 TC | | 74 | 98 | | 12 | |
| FSI0140QB | 74*98*12 TC(VMQ) | | 74 | 98 | | 12 | |
| FSI0278NB | 75*98*12 TB | | 75 | 98 | | 12 | |
| FSI0168NB | 76*98*12 HTCR | 91214-PB2-003 | 76 | 98 | | 12 | |
| FSI0159NB | 76*98*12 TC | | 76 | 98 | | 12 | |
| FSI0047NB | 78*98*12.4 SC | | 78 | 98 | | 12.4 | |
| FSI0235N0 | 80*98*7 VB2 | | 80 | 98 | | 7 | |
| FSI0005NB | 80*98*10 HTCL | 91214-PS2-003 | 80 | 98 | | 10 | |

| WLK CODE | OIL SEALS | DESCRIPTION | ID | OD1 | OD2 | H1 | H2 |
|-----------|-------------------------------|--------------------------|--------|--------|--------|--------|------|
| FSI0005QB | 80*98*10 HTCL (VMQ) | | 80 | 98 | | 10 | |
| FSI0166N0 | 86*98*6 VC | | 86 | 98 | | 6 | |
| FSI0134NB | 86.5*98*6 VC | ACESIL商標 | 86.5 | 98 | | 6 | |
| FSI0018N0 | 87*98*6 VC | 103204-02890(ACESIL商標) | 87 | 98 | | 6 | |
| FSI0115N0 | 87.5*98*6 VC | 103204-02880 | 87.5 | 98 | | 6 | |
| FSI0002N0 | 88*98*6 VC | 103203-02220(N22Y M/N BE | 88 | 98 | | 6 | |
| FSI0128NB | 69.85*98.425*12.7 SC | 2.750*3.875*0.50 SC | 69.85 | 98.425 | | 12.7 | |
| FSI9994NB | 76.2*98.425*11.913 SA | 3.000*3.875*0.469 SA紅漆 | 76.2 | 98.425 | | 11.913 | |
| FSI9958NB | 63.5*98.43*11.91 TB | | 63.5 | 98.43 | | 11.91 | |
| FSI9971NB | 66.68*98.43*12.7 TA | | 66.68 | 98.43 | | 12.7 | |
| FSI9983NB | 69.85*98.43*11.13 TB | | 69.85 | 98.43 | | 11.13 | |
| FSI9957NB | 69.85*98.43*11.13 TC | | 69.85 | 98.43 | | 11.13 | |
| FSI9997NB | 69.85*98.43*12.7 TB | | 69.85 | 98.43 | | 12.7 | |
| FSI9985NB | 69.85*98.43*12.7 TC | | 69.85 | 98.43 | | 12.7 | |
| FSI9951NB | 73.02*98.43*12.7 TC | | 73.02 | 98.43 | | 12.7 | |
| FSI9961NB | 76.2*98.43*11.13 KB | | 76.2 | 98.43 | | 11.13 | |
| FSI9966NB | 76.2*98.43*12.7 TA | | 76.2 | 98.43 | | 12.7 | |
| FSI9952NB | 79.38*98.43*12.7 SC | | 79.38 | 98.43 | | 12.7 | |
| FSI9992NB | 69.85*98.45*11.11 TB | 2.750*3.870*0.430 TB | 69.85 | 98.45 | | 11.11 | |
| FSI9999AB | 69.85*98.552*11.938 TB | 2.75*3.88*0.47 TB(PA)ACM | 69.85 | 98.552 | | 11.938 | |
| FSI9996NB | 73.03*98.83/106.38*11.91 TA5Y | 9864S Red painting | 73.03 | 98.83 | 106.38 | 11.91 | |
| FSI9998QB | 79.375*98.831*9.525 STGL | 3.125*3.891*0.375 STGL(V | 79.375 | 98.831 | | 9.525 | |
| FSI0305NB | 56*99*10/34 Y(TCA59Y) | MH034205 噴漆 | 56 | 99 | | 10 | 34 |
| FSI0211NB | 79*99*8 HTCL | BH5704E | 79 | 99 | | 8 | |
| FSI0184NB | 84*99*8 TC(Brown) | | 84 | 99 | | 8 | |
| FSI0019NB | 56*99.06*8 Y (RS-2A) | | 56 | 99.06 | | 8 | |
| FSI0021N0 | 57.15*99.21*6.35 OV | 2.250*3.906*0.250 OV | 57.15 | 99.21 | | 6.35 | |
| FSI0104NB | 74.4*99.5*7.7 SCS-S | MB-161134 | 74.4 | 99.5 | | 7.7 | |
| FSI9991NB | 69.6*99.97*12.7/20.7 HTGAWY | | 69.6 | 99.97 | | 12.7 | 20.7 |
| FSI0296NB | 35*100*10 TC(BLUE) | | 35 | 100 | | 10 | |
| FSI0313NB | 40*100*13 TC | | 40 | 100 | | 13 | |
| FSI0137NB | 45*100*10 TC | | 45 | 100 | | 10 | |
| FSI0132NB | 49*100*8 HSCY | 48.82*99.62*8/9.6 HSCY | 49 | 100 | | 8 | |
| FSI0259NB | 50*100*10 TB | | 50 | 100 | | 10 | |
| FSI0237NB | 50*100*10 TC | | 50 | 100 | | 10 | |
| FSI0237FB | 50*100*10 TC(VITON) | | 50 | 100 | | 10 | |
| FSI0193NB | 50*100*12 TC | | 50 | 100 | | 12 | |
| FSI0193FB | 50*100*12 TC(VITON)FKM | | 50 | 100 | | 12 | |
| FSI0228NB | 52*100*10 TC | | 52 | 100 | | 10 | |
| FSI0095NB | 55*100*10 TC | | 55 | 100 | | 10 | |
| FSI0095FB | 55*100*10 TC(VITON) | | 55 | 100 | | 10 | |
| FSI0077NB | 55*100*12 TC | | 55 | 100 | | 12 | |
| FSI0077FB | 55*100*12 TC(VITON) | | 55 | 100 | | 12 | |
| FSI0070NB | 55*100*13 SA2 | | 55 | 100 | | 13 | |
| FSI0269NB | 55*100*13 TC | | 55 | 100 | | 13 | |
| FSI0266NB | 55*100*16 SC | | 55 | 100 | | 16 | |
| FSI0271NB | 56*100*10 TB | | 56 | 100 | | 10 | |
| FSI0201NB | 56*100*10 TC | | 56 | 100 | | 10 | |
| FSI0174NB | 58*100*12 TC | | 58 | 100 | | 12 | |
| FSI0221NB | 60*100*10 SC | | 60 | 100 | | 10 | |
| FSI0179NB | 60*100*10 TC | | 60 | 100 | | 10 | |
| FSI0179FB | 60*100*10 TC(VITON) | | 60 | 100 | | 10 | |
| FSI0188NB | 60*100*11 TC | | 60 | 100 | | 11 | |
| FSI0079NB | 60*100*13 TC | | 60 | 100 | | 13 | |
| FSAJ0003N | 60*100*13.5 TC | | 60 | 100 | | 13.5 | |
| FSI0202NB | 62*100*10 TC | | 62 | 100 | | 10 | |
| FSI0212NB | 62*100*12 TC | | 62 | 100 | | 12 | |

| WLK CODE | OIL SEALS | DESCRIPTION | ID | OD1 | OD2 | H1 | H2 |
|-----------|---|----------------------|----|-----|-----|-----|----|
| FSI0298NB | 62*100*13 TB | | 62 | 100 | | 13 | |
| FSI0234NB | 62*100*13 TC | | 62 | 100 | | 13 | |
| FSI0230NB | 63*100*12 UDS-5(Y) | 9828-63104 | 63 | 100 | | 12 | |
| FSI0284NB | 64*100*13 SB | | 64 | 100 | | 13 | |
| FSI0053NB | 65*100*10 SC | | 65 | 100 | | 10 | |
| FSI0083NB | 65*100*10 TC | | 65 | 100 | | 10 | |
| FSI0083FB | 65*100*10 TC(VITON) | | 65 | 100 | | 10 | |
| FSI0106NB | 65*100*12 TBP | W029-33-065 | 65 | 100 | | 12 | |
| FSI0133NB | 65*100*12 TC | | 65 | 100 | | 12 | |
| FSI0133FB | 65*100*12 TC(VITON) | | 65 | 100 | | 12 | |
| FSI0197NB | 65*100*13 SC | | 65 | 100 | | 13 | |
| FSI0214NB | 65*100*13 TC | | 65 | 100 | | 13 | |
| FSI0214FB | 65*100*13 TC(VITON) | | 65 | 100 | | 13 | |
| FSI0247NB | 68*100*10 TC | | 68 | 100 | | 10 | |
| FSI0247FB | 68*100*10 TC(VITON) | | 68 | 100 | | 10 | |
| FSI0225NB | 68*100*12 TC | | 68 | 100 | | 12 | |
| FSI0183NB | 68*100*13 TC | | 68 | 100 | | 13 | |
| FSI0231NB | 70*100*6 SC | | 70 | 100 | | 6 | |
| FSI0297NB | 70*100*8 TC | | 70 | 100 | | 8 | |
| FSI0096FB | 70*100*10 SC(FKM)VITON | | 70 | 100 | | 10 | |
| FSI0014NB | 70*100*10 TC | MH-034065 | 70 | 100 | | 10 | |
| FSI0014FB | 70*100*10 TC(VITON) | | 70 | 100 | | 10 | |
| FSI0121NB | 70*100*12 TC | | 70 | 100 | | 12 | |
| FSI0121FB | 70*100*12 TC(VITON) | | 70 | 100 | | 12 | |
| FSI0129NB | 70*100*13 SC | | 70 | 100 | | 13 | |
| FSI0129FB | 70*100*13 SC(VITON) | | 70 | 100 | | 13 | |
| FSI0120NB | 70*100*13 TA | | 70 | 100 | | 13 | |
| FSI0196NB | 70*100*13 TB | | 70 | 100 | | 13 | |
| FSI0055NB | 70*100*13 TC | MH-034065 | 70 | 100 | | 13 | |
| FSI0055QB | 70*100*13 TC (VMQ) | | 70 | 100 | | 13 | |
| FSI0055FB | 70*100*13 TC(VITON) | | 70 | 100 | | 13 | |
| FSI0088NB | 72*100*10 TC | | 72 | 100 | | 10 | |
| FSI0088FB | 72*100*10 TC(VITON) | | 72 | 100 | | 10 | |
| FSI0288NB | 72*100*12 TB | | 72 | 100 | | 12 | |
| FSI0113NB | 72*100*12 TC | | 72 | 100 | | 12 | |
| FSI0113FB | 72*100*12 TC(VITON) | | 72 | 100 | | 12 | |
| FSI0177NB | 72*100*13 TC | | 72 | 100 | | 13 | |
| FSI0177FB | 72*100*13 TC(VITON) | | 72 | 100 | | 13 | |
| FSI0177QB | 72*100*13 TC(VMQ) | | 72 | 100 | | 13 | |
| FSI0206NB | 74*100*10 TB | MB-161122, MB-161153 | 74 | 100 | | 10 | |
| FSI0268NB | 74*100*13 TC | | 74 | 100 | | 13 | |
| FSI0268FB | 74*100*13 TC(VITON) | | 74 | 100 | | 13 | |
| FSI0017N0 | 75*100*7 VC | | 75 | 100 | | 7 | |
| FSI0241N0 | 75*100*8 VB | | 75 | 100 | | 8 | |
| FSI0204NB | 75*100*8.5 HTBCKL W/Felt | (BROWN) | 75 | 100 | | 8.5 | |
| FSI0057NB | 75*100*8.5 HTCL | 90311-75004 | 75 | 100 | | 8.5 | |
| FSI0057QB | 75*100*8.5 HTCL(VMQ) | | 75 | 100 | | 8.5 | |
| FSI0027FB | 75*100*10 SC(FKM)VITON | | 75 | 100 | | 10 | |
| FSI0027NB | 75*100*10 SC(S304) | | 75 | 100 | | 10 | |
| FSI0292NB | 75*100*10 TA4(NBR Brown + Red Painting) | | 75 | 100 | | 10 | |
| FSI0227NB | 75*100*10 TB | | 75 | 100 | | 10 | |
| FSI0058NB | 75*100*10 TC | | 75 | 100 | | 10 | |
| FSI0058FB | 75*100*10 TC(VITON) | | 75 | 100 | | 10 | |
| FSI0058QB | 75*100*10 TC(VMQ) | | 75 | 100 | | 10 | |
| FSI0190NB | 75*100*12 TC | | 75 | 100 | | 12 | |
| FSI0190FB | 75*100*12 TC(VITON) | | 75 | 100 | | 12 | |
| FSI0226NB | 75*100*12/13 TBYR | | 75 | 100 | | 12 | 13 |

| WLK CODE | OIL SEALS | DESCRIPTION | ID | OD1 | OD2 | H1 | H2 |
|-----------|--------------------------|-------------------------|----|-----|-----|------|----|
| FSI0308NB | 75*100*13 HTCL(VMQ) | | 75 | 100 | | 13 | |
| FSI0059NB | 75*100*13 SA (Green) | | 75 | 100 | | 13 | |
| FSI0060NB | 75*100*13 TA2 | | 75 | 100 | | 13 | |
| FSI0072NB | 75*100*13 TB | 42404-36010 | 75 | 100 | | 13 | |
| FSI0072FB | 75*100*13 TB(VITON) | | 75 | 100 | | 13 | |
| FSI1003NB | 75*100*13 TC | 90311-75114 | 75 | 100 | | 13 | |
| FSI1003FB | 75*100*13 TC(VITON) | | 75 | 100 | | 13 | |
| FSI1003QB | 75*100*13 TC(VMQ) | | 75 | 100 | | 13 | |
| FSI0163NB | 75*100*13 TCN | AP3618G | 75 | 100 | | 13 | |
| FSI0229NB | 75*100*13/18 HTB9R | 9828-75111 | 75 | 100 | | 13 | 18 |
| FSI0203NB | 75*100*17 HTCR | | 75 | 100 | | 17 | |
| FSI0264NB | 75*100*17 HTZR | | 75 | 100 | | 17 | |
| FSI0061NB | 75*100*17 TB | | 75 | 100 | | 17 | |
| FSI0282NB | 76*100*10 TC | | 76 | 100 | | 10 | |
| FSI1009NB | 76*100*12 TC | | 76 | 100 | | 12 | |
| FSI0062NB | 77*100*10 HTCL | 外徑紋路 | 77 | 100 | | 10 | |
| FSI0303NB | 77*100*10 SC | | 77 | 100 | | 10 | |
| FSI1010NB | 77*100*10 TC | | 77 | 100 | | 10 | |
| FSI0272NB | 77*100*11.5 HTGL | | 77 | 100 | | 11.5 | |
| FSI0276NB | 77*100*11.5 TC | | 77 | 100 | | 11.5 | |
| FSI0156NB | 78*100*10 SC | | 78 | 100 | | 10 | |
| FSI0110NB | 78*100*10 TC | | 78 | 100 | | 10 | |
| FSI0110FB | 78*100*10 TC(VITON) | | 78 | 100 | | 10 | |
| FSI0023NB | 78*100*13 TC | | 78 | 100 | | 13 | |
| FSI0023FB | 78*100*13 TC(VITON) | | 78 | 100 | | 13 | |
| FSI0274NB | 80*100*7 TC | | 80 | 100 | | 7 | |
| FSI0205NB | 80*100*8.5 HTBCKL W/Felt | (BROWN) | 80 | 100 | | 8.5 | |
| FSI0063NB | 80*100*8.5 HTCL | 90311-80003/80012 | 80 | 100 | | 8.5 | |
| FSI0063FB | 80*100*8.5 HTCL(VITON) | | 80 | 100 | | 8.5 | |
| FSI0063QB | 80*100*8.5 HTCL(VMQ) | | 80 | 100 | | 8.5 | |
| FSI0191NB | 80*100*8.5 TC | | 80 | 100 | | 8.5 | |
| FSI0064NB | 80*100*10 HTCL | 12279-01M00;90311-80009 | 80 | 100 | | 10 | |
| FSI0064QB | 80*100*10 HTCL(VMQ) | 12279-01M00/42L00 | 80 | 100 | | 10 | |
| FSI0098NB | 80*100*10 HTCR | 91214-PC6-003/13,NJ312 | 80 | 100 | | 10 | |
| FSI0098QB | 80*100*10 HTCR(VMQ) | AH3732F | 80 | 100 | | 10 | |
| FSI0167NB | 80*100*10 SC | | 80 | 100 | | 10 | |
| FSI0167FB | 80*100*10 SC(VITON)FKM | | 80 | 100 | | 10 | |
| FSI0065NB | 80*100*10 TB | | 80 | 100 | | 10 | |
| FSI0003NB | 80*100*10 TC | | 80 | 100 | | 10 | |
| FSI0003FB | 80*100*10 TC(FKM)VITON | | 80 | 100 | | 10 | |
| FSI0267NB | 80*100*10 TZ | | 80 | 100 | | 10 | |
| FSI0107NB | 80*100/106*10/11 HTC5L | 12279-T7200 | 80 | 100 | 106 | 10 | 11 |
| FSI0099NB | 80*100*12 HTCL | 90311-80001/02 | 80 | 100 | | 12 | |
| FSI0099QB | 80*100*12 HTCL(VMQ) | | 80 | 100 | | 12 | |
| FSI0287NB | 80*100*12 SA | | 80 | 100 | | 12 | |
| FSI0287FB | 80*100*12 SA(VITON) | | 80 | 100 | | 12 | |
| FSI0263FB | 80*100*12 SC(VITON) | TC修掉附唇 | 80 | 100 | | 12 | |
| FSI0146NB | 80*100*12 TA | | 80 | 100 | | 12 | |
| FSI0281NB | 80*100*12 TB | | 80 | 100 | | 12 | |
| FSI0066NB | 80*100*12 TC | | 80 | 100 | | 12 | |
| FSI0066QB | 80*100*12 TC (VMQ) | | 80 | 100 | | 12 | |
| FSI0066FB | 80*100*12 TC(FKM)VITON | VITON | 80 | 100 | | 12 | |
| FSI0067NB | 80*100*13 HTCL | 12279-R4601 | 80 | 100 | | 13 | |
| FSI0067QB | 80*100*13 HTCL(VMQ) | | 80 | 100 | | 13 | |
| FSI0299NB | 80*100*13 TA | | 80 | 100 | | 13 | |
| FSI1002NB | 80*100*13 TC | 12279-21010 (A4600) | 80 | 100 | | 13 | |
| FSI1002FB | 80*100*13 TC(VITON)FKM | | 80 | 100 | | 13 | |

| WLK CODE | OIL SEALS | DESCRIPTION | ID | OD1 | OD2 | H1 | H2 |
|-----------|---------------------------|------------------------|--------|--------|-----|--------|----|
| FSI1002QB | 80*100*13 TC(VMQ) | | 80 | 100 | | 13 | |
| FSI0256NB | 82*100*8 TC | | 82 | 100 | | 8 | |
| FSI0068NB | 83*100*9 HTCL | B630-11-312 | 83 | 100 | | 9 | |
| FSI0068QB | 83*100*9 HTCL(VMQ) | B63011312(MAZDA PN) | 83 | 100 | | 9 | |
| FSI0244NB | 84*100*10 SC | | 84 | 100 | | 10 | |
| FSI0149NB | 84*100*10 TB | 9828-85106 | 84 | 100 | | 10 | |
| FSI0148NB | 84*100*10 TC | | 84 | 100 | | 10 | |
| FSI0311NB | 84*100*13 TC | | 84 | 100 | | 13 | |
| FSI1006FB | 85*100*6 TC(VITON)FKM | | 85 | 100 | | 6 | |
| FSI0126NB | 85*100*8 TC | | 85 | 100 | | 8 | |
| FSI0162NB | 85*100*9 TC | | 85 | 100 | | 9 | |
| FSI0125NB | 85*100*10 TB | | 85 | 100 | | 10 | |
| FSI0153NB | 85*100*10 TC | | 85 | 100 | | 10 | |
| FSI0153FB | 85*100*10 TC(VITON) | | 85 | 100 | | 10 | |
| FSI0013NB | 85*100*12 TC | | 85 | 100 | | 12 | |
| FSI0013FB | 85*100*12 TC(VITON) | | 85 | 100 | | 12 | |
| FSI0192NB | 85*100*13 TC | | 85 | 100 | | 13 | |
| FSI0100NB | 86*100*9 HTCL | BROWN | 86 | 100 | | 9 | |
| FSI0069NB | 86*100*10 HTCL | 12279-43G00 | 86 | 100 | | 10 | |
| FSI0170QB | 86*100*10 HTG(VMQ) | VMQ(Gray灰色)NDK | 86 | 100 | | 10 | |
| FSI0260NB | 86*100*10 TC | | 86 | 100 | | 10 | |
| FSI0260FB | 86*100*10 TC(VITON) | | 86 | 100 | | 10 | |
| FSI0286QB | 87*100*8 HTCL(VMQ) | | 87 | 100 | | 8 | |
| FSI0309NB | 90*100*10 TC | | 90 | 100 | | 10 | |
| FSI0257NB | 90*100*12 TC | | 90 | 100 | | 12 | |
| FSM0011N0 | 140*100*12 X3 | | 140 | 100 | | 12 | |
| PMM0011C | 140*100*12 X3 (鐵殼) | WEAR RING | 140 | 100 | | 12 | |
| FSN0104N0 | 150*100*12 X3 | | 150 | 100 | | 12 | |
| FSJ0035NB | 72.22*100.05*12.57 TBP | 2.843*3.939*0.495TBP紅漆 | 72.22 | 100.05 | | 12.57 | |
| FSJ0122N0 | 55*101*4.7 SPOVC | 90043-12023-000 | 55 | 101 | | 4.7 | |
| FSJ0254NB | 80*101*10.5 TB5Y | | 80 | 101 | | 10.5 | |
| FSJ9968NB | 57.15*101.6*12.7 TA | | 57.15 | 101.6 | | 12.7 | |
| FSJ9994NB | 63.5*101.6*9.53 TA | | 63.5 | 101.6 | | 9.53 | |
| FSJ9970NB | 63.5*101.6*11.91 SC | | 63.5 | 101.6 | | 11.91 | |
| FSJ9982NB | 63.5*101.6*12.7 SC | | 63.5 | 101.6 | | 12.7 | |
| FSJ9967NB | 66.68*101.6*9.53 TA | | 66.68 | 101.6 | | 9.53 | |
| FSJ9996NB | 69.85*101.6*12.7 SC | 2.750*4.000*0.500 SC | 69.85 | 101.6 | | 12.7 | |
| FSJ9960NB | 69.85*101.6*12.7 TC | 無商標 | 69.85 | 101.6 | | 12.7 | |
| FSJ9997NB | 72.62*101.6*17.475 UM | 2.859*4.000*0.688 UM | 72.62 | 101.6 | | 17.475 | |
| FSJ9978NB | 73.02*101.6*12.7 TA | 咖啡色 紅漆 | 73.02 | 101.6 | | 12.7 | |
| FSJ9975NB | 73.02*101.6*15.47 TC | | 73.02 | 101.6 | | 15.47 | |
| FSJ9948NB | 73.02*101.6*15.47 TC4 | 無商標(NBR70) | 73.02 | 101.6 | | 15.47 | |
| FSJ0082NB | 73.03*101.6*12.7 TC | 2.875*4.000*0.500 TC | 73.03 | 101.6 | | 12.7 | |
| FSJ9947NB | 73.03*101.6*15.88 TAFY | 2.875*4.008*0.625TAF毛氈 | 73.03 | 101.6 | | 15.88 | |
| FSJ9998NB | 74.61*101.6*9.5 TC | 2.937*4.000*0.374 TC | 74.61 | 101.6 | | 9.5 | |
| FSJ9993NB | 74.61*101.6*15.87 TA | | 74.61 | 101.6 | | 15.87 | |
| FSJ0194NB | 74.625*101.6*11.13 TA | 2.938*4*0.438 TA | 74.625 | 101.6 | | 11.13 | |
| FSJ0095NB | 74.625*101.6*11.13 TB | 2.938*4.000*0.438 TB | 74.625 | 101.6 | | 11.13 | |
| FSJ9974NB | 74.63*101.6*11.91 TB | | 74.63 | 101.6 | | 11.91 | |
| FSJ0083NB | 76.15*101.6*12.7 TA | | 76.15 | 101.6 | | 12.7 | |
| FSJ9944NB | 76.2*101.6*9.53 SB | | 76.2 | 101.6 | | 9.53 | |
| FSJ9984NB | 76.2*101.6*9.53 SC | | 76.2 | 101.6 | | 9.53 | |
| FSJ9992NB | 76.2*101.6*9.53 TC | | 76.2 | 101.6 | | 9.53 | |
| FSJ9992FB | 76.2*101.6*9.53 TC(VITON) | | 76.2 | 101.6 | | 9.53 | |
| FSJ0080NB | 76.2*101.6*10.9 TC | | 76.2 | 101.6 | | 10.9 | |
| FSJ9954NB | 76.2*101.6*11.13 TA | | 76.2 | 101.6 | | 11.13 | |

| WLK CODE | OIL SEALS | DESCRIPTION | ID | OD1 | OD2 | H1 | H2 |
|-----------|------------------------------|----------------------|-------|--------|-------|-------|------|
| FSJ9981NB | 76.2*101.6*11.13 TB | | 76.2 | 101.6 | | 11.13 | |
| FSJ9995NB | 76.2*101.6*11.13 TC | | 76.2 | 101.6 | | 11.13 | |
| FSJ9991NB | 76.2*101.6*11.91 TA | | 76.2 | 101.6 | | 11.91 | |
| FSJ9977NB | 76.2*101.6*11.91 TB | | 76.2 | 101.6 | | 11.91 | |
| FSJ9953NB | 76.2*101.6*12.7 SC | | 76.2 | 101.6 | | 12.7 | |
| FSJ9943NB | 76.2*101.6*12.7 TA | | 76.2 | 101.6 | | 12.7 | |
| FSJ9980NB | 76.2*101.6*12.7 TC | 3.000*4.000*0.500 TC | 76.2 | 101.6 | | 12.7 | |
| FSJ9985NB | 76.20*101.60*12.7 SC | | 76.2 | 101.6 | | 12.7 | |
| FSJ0061NB | 76.20*101.60*12.7 TC | | 76.2 | 101.6 | | 12.7 | |
| FSJ9964NB | 79.38*101.6*9.53 TA | | 79.38 | 101.6 | | 9.53 | |
| FSJ9965NB | 79.38*101.6*9.53 TB | | 79.38 | 101.6 | | 9.53 | |
| FSJ9955NB | 79.38*101.6*12.7 SC | 3.125*4.000*0.500 SC | 79.38 | 101.6 | | 12.7 | |
| FSJ9988NB | 82.55*101.6*9.53 TC | | 82.55 | 101.6 | | 9.53 | |
| FSJ9963NB | 82.55*101.6*12.7 TC | 3.25*4.00*0.50 TC | 82.55 | 101.6 | | 12.7 | |
| FSJ9971NB | 69.85*101.68*9.53 TB | | 69.85 | 101.68 | | 9.53 | |
| FSJ9969NB | 69.85*101.68*11.89 TA | 2.75*4.003*0.468 TA | 69.85 | 101.68 | | 11.89 | |
| FSJ9979NB | 76.2*101.68*11.13 TA | | 76.2 | 101.68 | | 11.13 | |
| FSJ9958NB | 76.2*101.68*12.7 SB2 | | 76.2 | 101.68 | | 12.7 | |
| FSJ9959NB | 76.2*101.68*12.7 TA | | 76.2 | 101.68 | | 12.7 | |
| FSJ0047NB | 46*102*10/16 SCY(ADS-S) | MB-308933 | 46 | 102 | | 10 | 16 |
| FSJ0238NB | 48*102*10/16 SCY | | 48 | 102 | | 10 | 16 |
| FSJ0199NB | 49*102*8 HSCY | | 49 | 102 | | 8 | |
| FSI0215NB | 49*102*8 TC | | 49 | 102 | | 8 | |
| FSJ0250NB | 49*102*10 Y | | 49 | 102 | | 10 | |
| FSJ0253NB | 52*102*10.5/15.5 Y | | 52 | 102 | | 10.5 | 15.5 |
| FSJ0043NB | 58*102*8/22 HTAWY | 9825-58109 | 58 | 102 | | 8 | 22 |
| FSJ0098NB | 58*102*9 HTBR | | 58 | 102 | | 9 | |
| FSJ0078NB | 58*102*12 HTBR | 90311-58002 | 58 | 102 | | 12 | |
| FSJ0205NB | 70*102*13 TC | | 70 | 102 | | 13 | |
| FSJ0018NB | 75*102*12 TC | | 75 | 102 | | 12 | |
| FSJ0081NB | 75*102*13 TC | | 75 | 102 | | 13 | |
| FSJ0195NB | 76*102*9.8/18.5 TA9 | | 76 | 102 | | 9.8 | 18.5 |
| FSJ0119NB | 77*102*9/19 TAX4Y | 5-09625-030-0 | 77 | 102 | | 9 | 19 |
| FSJ0157NB | 82*102*12 TC | | 82 | 102 | | 12 | |
| FSJ0210NB | 84*102*13 TC | | 84 | 102 | | 13 | |
| FSJ0178NB | 85*102*12 HTCKL W/Felt | | 85 | 102 | | 12 | |
| FSJ0067NB | 85*102*12 HTCL | | 85 | 102 | | 12 | |
| FSJ0067QB | 85*102*12 HTCL(VMQ) Black | | 85 | 102 | | 12 | |
| FSJ0174NB | 85*102*13 HTCKL VITON W/Felt | | 85 | 102 | | 13 | |
| FSJ0131NB | 85*102*13 TC | | 85 | 102 | | 13 | |
| FSJ0184NB | 88*102*10 TC | | 88 | 102 | | 10 | |
| FSJ0139NB | 58*103*11/19.5 TBY(HTB9R) | 實際HTB9R | 58 | 103 | | 11 | 19.5 |
| FSJ0124NB | 58*103*12/19.5 TC9 | 9-09724-010-0 | 58 | 103 | | 12 | 19.5 |
| FSJ0113NB | 60*103*10/34 TAX(N) | MC-827472 | 60 | 103 | | 10 | 34 |
| FSJ0203NB | 60*103*12 TC | | 60 | 103 | | 12 | |
| FSJ0142NB | 60*103*12/20 TB9 | 1-09625-046-0 | 60 | 103 | | 12 | 20 |
| FSJ0152NB | 83*103*8 HTCL(Brown) | BH6381E | 83 | 103 | | 8 | |
| FSJ0036NB | 85*103*8 HTCL | MD-150161 | 85 | 103 | | 8 | |
| FSJ0036QB | 85*103*8 HTCL (VMQ) | | 85 | 103 | | 8 | |
| FSI0036FB | 85*103*8 HTCL(VITON) | | 85 | 103 | | 8 | |
| FSJ0123NB | 86*103*8 HTCL | | 86 | 103 | | 8 | |
| FSJ0123QB | 86*103*8 HTCL(VMQ) | | 86 | 103 | | 8 | |
| FSJ0096NB | 62*104*12/20 TB9 | Y00127-165 | 62 | 104 | | 12 | 20 |
| FSJ0118NB | 62*104/117.5*12/18.5 TB59 | BD3245E | 62 | 104 | 117.5 | 12 | 18.5 |
| FSJ0154NB | 84*104*8.5 HTCL | BH5861F | 84 | 104 | | 8.5 | |
| FSJ0154AB | 84*104*8.5 HTCL(ACM) | R901411BH5861F | 84 | 104 | | 8.5 | |
| FSJ0154QB | 84*104*8.5 HTCL(VMQ) | BH5861F | 84 | 104 | | 8.5 | |

| WLK CODE | OIL SEALS | DESCRIPTION | ID | OD1 | OD2 | H1 | H2 |
|-----------|-----------------------|----------------------|-------|--------|-----|-----|-------|
| FSJ0137QB | 84*104*8.5 HTGL(VMQ) | | 84 | 104 | | 8.5 | |
| FSJ0033NB | 84*104*11 HTCL | 12279-D0100 | 84 | 104 | | 11 | |
| FSJ0033FB | 84*104*11 HTCL(VITON) | | 84 | 104 | | 11 | |
| FSJ0033QB | 84*104*11 HTCL(VMQ) | | 84 | 104 | | 11 | |
| FSJ0150NB | 86*104*11 HTGL | | 86 | 104 | | 11 | |
| FSJ0044QB | 86*104*11 HTGL (VMQ) | | 86 | 104 | | 11 | |
| FSN0066NB | 90*104*11 HTBCL | 96298408 | 90 | 104 | | 11 | |
| FSN0066AB | 90*104*11 HTBCL(ACM) | 9629840 | 90 | 104 | | 11 | |
| FSN0056NB | 90*104*11 HTCL | | 90 | 104 | | 11 | |
| FSJ0011N0 | 99*104*9 軟 | DRB442 | 99 | 104 | | | 9 |
| FSJ9962NB | 76.2*104.78*12.7 TC | 3.000*4.125*0.500 TC | 76.2 | 104.78 | | | 12.7 |
| FSJ9952NB | 77.8*104.78*12.7 TC | | 77.8 | 104.78 | | | 12.7 |
| FSJ9990NB | 79.38*104.78*6.35 VB | | 79.38 | 104.78 | | | 6.35 |
| FSJ9961NB | 79.38*104.78*12.7 TB | | 79.38 | 104.78 | | | 12.7 |
| FSJ9989NB | 79.38*104.78*12.7 TC | | 79.38 | 104.78 | | | 12.7 |
| FSJ9950NB | 82.55*104.78*12.7 TB | | 82.55 | 104.78 | | | 12.7 |
| FSJ9987NB | 85.73*104.78*9.53 SA | | 85.73 | 104.78 | | | 9.53 |
| FSJ0268NB | 88.9*104.78*7.95 SC | | 88.9 | 104.78 | | | 7.95 |
| FSJ9956NB | 88.9*104.78*9.53 TC | | 88.9 | 104.78 | | | 9.53 |
| FSJ0186NB | 60*105*12 TC | | 60 | 105 | | | 12 |
| FSJ0166NB | 60*105*13 TB | | 60 | 105 | | | 13 |
| FSJ0192NB | 65*105*10 TC | | 65 | 105 | | | 10 |
| FSJ0193NB | 65*105*12 TC | | 65 | 105 | | | 12 |
| FSJ0244NB | 70*105*10 TC(BLUE) | | 70 | 105 | | | 10 |
| FSJ0094NB | 70*105*12 TC | | 70 | 105 | | | 12 |
| FSJ0128NB | 70*105*13 TC | | 70 | 105 | | | 13 |
| FSJ0128FB | 70*105*13 TC(VITON) | | 70 | 105 | | | 13 |
| FSJ0133NB | 72*105*10 TC | | 72 | 105 | | | 10 |
| FSJ0232NB | 72*105*12 TC | | 72 | 105 | | | 12 |
| FSJ9951NB | 72*105*13 SA | | 72 | 105 | | | 13 |
| FSJ0270NB | 72*105*13 TA | | 72 | 105 | | | 13 |
| FSJ0235NB | 72*105*13 TB | | 72 | 105 | | | 13 |
| FSJ0206NB | 72*105*13 TC | | 72 | 105 | | | 13 |
| FSJ0252FB | 75*105*10 TA(VITON) | | 75 | 105 | | | 10 |
| FSJ0076NB | 75*105*10 TC | | 75 | 105 | | | 10 |
| FSJ0143NB | 75*105*12 TA | | 75 | 105 | | | 12 |
| FSJ0134NB | 75*105*12 TB | | 75 | 105 | | | 12 |
| FSJ0006NB | 75*105*12 TC | | 75 | 105 | | | 12 |
| FSJ0006FB | 75*105*12 TC(VITON) | | 75 | 105 | | | 12 |
| FSJ0218NB | 75*105*13 SA | | 75 | 105 | | | 13 |
| FSJ0059NB | 75*105*13 TC | | 75 | 105 | | | 13 |
| FSJ0059FB | 75*105*13 TC(VITON) | | 75 | 105 | | | 13 |
| FSJ0019NB | 75*105*15 TB | 9958-57-5055 | 75 | 105 | | | 15 |
| FSJ0239NB | 75*105*15 TC | | 75 | 105 | | | 15 |
| FSJ0239FB | 75*105*15 TC(VITON) | | 75 | 105 | | | 15 |
| FSJ0022NB | 76*105*12 TC | | 76 | 105 | | | 12 |
| FSJ0208NB | 78*105*13 SC | | 78 | 105 | | | 13 |
| FSJ0146NB | 80*105*8 TC | | 80 | 105 | | | 8 |
| FSJ0177NB | 80*105*10 TB | | 80 | 105 | | | 10 |
| FSJ0063NB | 80*105*10 TC | | 80 | 105 | | | 10 |
| FSJ0063FB | 80*105*10 TC(VITON) | | 80 | 105 | | | 10 |
| FSJ0007NB | 80*105*12 SC | | 80 | 105 | | | 12 |
| FSJ0064NB | 80*105*12 TC | | 80 | 105 | | | 12 |
| FSJ0064FB | 80*105*12 TC(VITON) | | 80 | 105 | | | 12 |
| FSJ0004NB | 80*105*12/14 TCY | | 80 | 105 | | | 12 14 |
| FSJ0090NB | 80*105*13 HTCL | 0305-11-399 | 80 | 105 | | | 13 |
| FSJ0090QB | 80*105*13 HTCL(VMQ) | | 80 | 105 | | | 13 |

| WLK CODE | OIL SEALS | DESCRIPTION | ID | OD1 | OD2 | H1 | H2 |
|-----------|-------------------------|---------------|----|-----|-----|-----|----|
| FSJ0103NB | 80*105*13 KC | 43252-82100 | 80 | 105 | | 13 | |
| FSJ0176NB | 80*105*13 TB | | 80 | 105 | | 13 | |
| FSJ0246FB | 80*105*13 TB(VITON) | | 80 | 105 | | 13 | |
| FSJ1004NB | 80*105*13 TC | 0305-11-399 | 80 | 105 | | 13 | |
| FSJ1004FB | 80*105*13 TC(VITON) | | 80 | 105 | | 13 | |
| FSJ0191NB | 80*105*13 TCN | | 80 | 105 | | 13 | |
| FSJ0257NB | 80*105*13/19 TB9 | | 80 | 105 | | 13 | 19 |
| FSJ0002NB | 80*105*15 TC6 | | 80 | 105 | | 15 | |
| FSJ0171NB | 82*105*10 TC | | 82 | 105 | | 10 | |
| FSJ0030NB | 82*105*11 TC | | 82 | 105 | | 11 | |
| FSJ0030QB | 82*105*11 TC (VMQ) | | 82 | 105 | | 11 | |
| FSJ0221NB | 82*105*12 SC | | 82 | 105 | | 12 | |
| FSJ0159NB | 82*105*12 TC | | 82 | 105 | | 12 | |
| FSJ0159FB | 82*105*12 TC(VITON)FKM | | 82 | 105 | | 12 | |
| FSJ0031NB | 82*105*13 FTC(HTC5) | 9-09924-449-0 | 82 | 105 | | 13 | |
| FSJ0149NB | 82*105*13 HTCL | | 82 | 105 | | 13 | |
| FSJ0075NB | 82*105*13 HTCL5 | 9-09924-449-0 | 82 | 105 | | 13 | |
| FSJ0085NB | 82*105*13 TC | | 82 | 105 | | 13 | |
| FSJ0085FB | 82*105*13 TC(VITON) | | 82 | 105 | | 13 | |
| FSJ0237NB | 85*105*8 SC | | 85 | 105 | | 8 | |
| FSJ0251NB | 85*105*8 TC | | 85 | 105 | | 8 | |
| FSJ0039NB | 85*105*10 HSBL | | 85 | 105 | | 10 | |
| FSJ0039FB | 85*105*10 HSBL (FKM) | | 85 | 105 | | 10 | |
| FSJ0187NB | 85*105*10 HTBCKL W/Felt | | 85 | 105 | | 10 | |
| FSJ0038NB | 85*105*10 HTCL | 90311-85003 | 85 | 105 | | 10 | |
| FSJ0038QB | 85*105*10 HTCL (VMQ) | 90310-85003 | 85 | 105 | | 10 | |
| FSJ0190NB | 85*105*10 SC | | 85 | 105 | | 10 | |
| FSJ0261NB | 85*105*10 TB | | 85 | 105 | | 10 | |
| FSJ0040NB | 85*105*10 TC | | 85 | 105 | | 10 | |
| FSJ0040FB | 85*105*10 TC(VITON) | | 85 | 105 | | 10 | |
| FSJ0126NB | 85*105*10/11 TB9(HTBL) | | 85 | 105 | | 10 | 11 |
| FSJ0041NB | 85*105*12 HTGL | | 85 | 105 | | 12 | |
| FSJ0041QB | 85*105*12 HTGL(VMQ) | | 85 | 105 | | 12 | |
| FSJ0224FB | 85*105*12 OSC(FKM)VITON | VITON | 85 | 105 | | 12 | |
| FSJ0236NB | 85*105*12 TB | | 85 | 105 | | 12 | |
| FSJ0108NB | 85*105*12 TC | | 85 | 105 | | 12 | |
| FSJ0108FB | 85*105*12 TC(VITON) | | 85 | 105 | | 12 | |
| FSJ0042NB | 85*105*13 HTCL | 90311-85001 | 85 | 105 | | 13 | |
| FSJ0102NB | 85*105*13 HTCL | | 85 | 105 | | 13 | |
| FSJ0172NB | 85*105*13 SA | | 85 | 105 | | 13 | |
| FSJ0196NB | 85*105*13 TA | | 85 | 105 | | 13 | |
| FSJ0219NB | 85*105*13 TB | | 85 | 105 | | 13 | |
| FSJ0071NB | 85*105*13 TC | | 85 | 105 | | 13 | |
| FSJ0071FB | 85*105*13 TC(VITON) | | 85 | 105 | | 13 | |
| FSJ0259NB | 88*105*12 TB | | 88 | 105 | | 12 | |
| FSJ0151NB | 89*105*10 HTCL | 90311-89001 | 89 | 105 | | 10 | |
| FSJ0115NB | 89*105*10 HTCR | | 89 | 105 | | 10 | |
| FSJ0226NB | 90*105*6 TC | | 90 | 105 | | 6 | |
| FSJ0227NB | 90*105*8 TB | | 90 | 105 | | 8 | |
| FSJ0132NB | 90*105*10 TC | | 90 | 105 | | 10 | |
| FSJ0132FB | 90*105*10 TC(VITON) | | 90 | 105 | | 10 | |
| FSJ0231NB | 90*105*12 TC | | 90 | 105 | | 12 | |
| FSJ0066NB | 90*105*13 TC | | 90 | 105 | | 13 | |
| FSJ0066FB | 90*105*13 TC(VITON)FKM | | 90 | 105 | | 13 | |
| FSJ0097NB | 95*105*10 TC | | 95 | 105 | | 10 | |
| FSJ0212NB | 75*106*10 TC | | 75 | 106 | | 10 | |
| FSJ0140NB | 88*106*8.5 HTBL | | 88 | 106 | | 8.5 | |

| WLK CODE | OIL SEALS | DESCRIPTION | ID | OD1 | OD2 | H1 | H2 |
|-----------|--------------------------------------|--------------------------|-------|--------|-----|-------|------|
| FSJ0089NB | 88*106*8.5 HTCL | 90311-88001 | 88 | 106 | | 8.5 | |
| FSJ0240NB | 88*106*8.5 TC | | 88 | 106 | | 8.5 | |
| FSJ0240FB | 88*106*8.5 TC(VITON) | | 88 | 106 | | 8.5 | |
| FSJ0129NB | 88*106*10 TC | | 88 | 106 | | 10 | |
| FSJ0099NB | 75*107*8 HTCL | 90311-75016 | 75 | 107 | | 8 | |
| FSJ0099FB | 75*107*8 HTCL (FKM)VITON | 90311-75016 | 75 | 107 | | 8 | |
| FSJ0099QB | 75*107*8 HTCL(VMQ) | BH6249E | 75 | 107 | | 8 | |
| FSJ9957NB | 76.2*107.95*11.13 TA | | 76.2 | 107.95 | | 11.13 | |
| FSJ9973NB | 76.2*107.95*11.13 TB | 3.000*4.250*0.438 TB | 76.2 | 107.95 | | 11.13 | |
| FSJ9976NB | 76.2*107.95*12.7 SC | | 76.2 | 107.95 | | 12.7 | |
| FSJ9941NB | 76.2*107.95*12.7 TC | | 76.2 | 107.95 | | 12.7 | |
| FSJ9972NB | 79.38*107.95*12.7 TA | | 79.38 | 107.95 | | 12.7 | |
| FSJ9949NB | 80.98*107.95*12.7 TC | | 80.98 | 107.95 | | 12.7 | |
| FSJ9949FB | 80.98*107.95*12.7 TC(FKM | VITON | 80.98 | 107.95 | | 12.7 | |
| FSJ9966NB | 82.55*107.95*9.53 TB | | 82.55 | 107.95 | | 9.53 | |
| FSJ9946NB | 82.55*107.95*9.53 TBP Green Painting | | 82.55 | 107.95 | | 9.53 | |
| FSJ0267NB | 82.55*107.95*11.13 TA | | 82.55 | 107.95 | | 11.13 | |
| FSJ9942NB | 82.55*107.95*11.13 TB(FKM) | VITON | 82.55 | 107.95 | | 11.13 | |
| FSJ9945NB | 82.55*107.95*12.7 TA | | 82.55 | 107.95 | | 12.7 | |
| FSJ9983NB | 82.55*107.95*12.7 TB | 3.25*4.25*0.50 TB | 82.55 | 107.95 | | 12.7 | |
| FSJ9999NB | 82.55*107.95*12.7 TC | 3.25*4.25*0.50 TC | 82.55 | 107.95 | | 12.7 | |
| FSJ9999FB | 82.55*107.95*12.7 TC(FKM) | 3.25*4.25*0.50 TC(VITON) | 82.55 | 107.95 | | 12.7 | |
| FSJ9940NB | 82.55*107.95*15.88 TB | | 82.55 | 107.95 | | 15.88 | |
| FSJ0107NB | 88.9*107.95*12.7 SC | 3.5*4.25*0.50 SC | 88.9 | 107.95 | | 12.7 | |
| FSJ0020NB | 75*108*10/20 TA29 | 90311-75003 | 75 | 108 | | 10 | 20 |
| FSJ0207NB | 75*108*13 TZ | | 75 | 108 | | 13 | |
| FSJ0029NB | 80*108*12 TC | C5NN4969D(80957) | 80 | 108 | | 12 | |
| FSJ0145NB | 88*108*11 TC | | 88 | 108 | | 11 | |
| FSJ0185NB | 90*108/111*10/12 KCR | FOR PRADO | 90 | 108 | 111 | 10 | 12 |
| FSI0273NB | 48*108.5*13/14 UES-35 | 9828-48112 | 48 | 108.5 | | 13 | 14 |
| FSJ0220NB | 85*109*11 TC(BROWN) | | 85 | 109 | | 11 | |
| FSJ0183NB | 89*109*10.3 HTCL | F32Z-6701B | 89 | 109 | | 10.3 | |
| FSJ0092NB | 90*109*9/10.5 HTCL | FS01-11-399 | 90 | 109 | | 9 | 10.5 |
| FSJ0092QB | 90*109*9/10.5 HTCL(VMQ) | 89*109*9/10.5 HTC9L | 90 | 109 | | 9 | 10.5 |
| FSJ0109NB | 50*110*10 TC | | 50 | 110 | | 10 | |
| FSJ0266NB | 50*110*12 SC | | 50 | 110 | | 12 | |
| FSJ0155NB | 50*110*12 TC | | 50 | 110 | | 12 | |
| FSJ0198NB | 55*110*10 TC | | 55 | 110 | | 10 | |
| FSJ0234NB | 57*110*10 SC | | 57 | 110 | | 10 | |
| FSJ0112NB | 57*110*10 TA | | 57 | 110 | | 10 | |
| FSJ0223NB | 60*110*8 TC | | 60 | 110 | | 8 | |
| FSJ0116NB | 60*110*10 TC | | 60 | 110 | | 10 | |
| FSJ0116FB | 60*110*10 TC(VITON) | | 60 | 110 | | 10 | |
| FSJ0104NB | 60*110*12 SC | | 60 | 110 | | 12 | |
| FSJ0091NB | 60*110*12 TC | | 60 | 110 | | 12 | |
| FSJ0091FB | 60*110*12 TC(VITON) | | 60 | 110 | | 12 | |
| FSJ0213NB | 60*110*13 SC | | 60 | 110 | | 13 | |
| FSJ0088NB | 60*110*13 TC | | 60 | 110 | | 13 | |
| FSJ0088FB | 60*110*13 TC(VITON) | | 60 | 110 | | 13 | |
| FSJ0211NB | 62*110*13 TC | | 62 | 110 | | 13 | |
| FSJ0135NB | 65*110*9 TC(BROWN) | | 65 | 110 | | 9 | |
| FSJ0170NB | 65*110*10 TA | | 65 | 110 | | 10 | |
| FSJ0201NB | 65*110*10 TC | | 65 | 110 | | 10 | |
| FSJ0201FB | 65*110*10 TC(VITON) | | 65 | 110 | | 10 | |
| FSJ0265NB | 65*110*12 TA | | 65 | 110 | | 12 | |
| FSJ0138NB | 65*110*12 TC | | 65 | 110 | | 12 | |
| FSJ0262NB | 65*110*13 TC(VITON) | | 65 | 110 | | 13 | |

| WLK CODE | OIL SEALS | DESCRIPTION | ID | OD1 | OD2 | H1 | H2 |
|-----------|------------------------|-------------|----|-----|-----|----|----|
| FSJ0188NB | 68*110*10 TC | | 68 | 110 | | 10 | |
| FSJ0106NB | 68*110*13 SA | | 68 | 110 | | 13 | |
| FSJ0204NB | 68*110*13 TC | | 68 | 110 | | 13 | |
| FSI0073NB | 70*110*8 SC | | 70 | 110 | | 8 | |
| FSI0312NB | 70*110*8 TC | | 70 | 110 | | 8 | |
| FSI0312FB | 70*110*8 TC(VITON) | | 70 | 110 | | 8 | |
| FSJ0045NB | 70*110*10 SB | | 70 | 110 | | 10 | |
| FSJ0258NB | 70*110*10 SC | | 70 | 110 | | 10 | |
| FSJ0058NB | 70*110*10 TC | | 70 | 110 | | 10 | |
| FSJ0058FB | 70*110*10 TC(VITON) | | 70 | 110 | | 10 | |
| FSJ0180NB | 70*110*12 TB | | 70 | 110 | | 12 | |
| FSJ0079NB | 70*110*12 TC | | 70 | 110 | | 12 | |
| FSJ0079FB | 70*110*12 TC(VITON) | | 70 | 110 | | 12 | |
| FSJ0046NB | 70*110*13 TC | | 70 | 110 | | 13 | |
| FSJ0046FB | 70*110*13 TC(VITON) | | 70 | 110 | | 13 | |
| FSJ0156NB | 72*110*13 TC | | 72 | 110 | | 13 | |
| FSJ0141NB | 75*110*10 TC | | 75 | 110 | | 10 | |
| FSJ0141FB | 75*110*10 TC(VITON) | | 75 | 110 | | 10 | |
| FSJ0111NB | 75*110*12 TC | | 75 | 110 | | 12 | |
| FSJ0111FB | 75*110*12 TC(VITON) | | 75 | 110 | | 12 | |
| FSJ0163NB | 75*110*13 TA | | 75 | 110 | | 13 | |
| FSJ0125NB | 75*110*13 TB | | 75 | 110 | | 13 | |
| FSJ0060NB | 75*110*13 TC | | 75 | 110 | | 13 | |
| FSJ0060QB | 75*110*13 TC (VMQ) | | 75 | 110 | | 13 | |
| FSJ0060FB | 75*110*13 TC(VITON) | | 75 | 110 | | 13 | |
| FSJ0245NB | 78*110*12 TC | | 78 | 110 | | 12 | |
| FSJ0072NB | 78*110*13 TC | | 78 | 110 | | 13 | |
| FSJ0160NB | 79*110*12 SC | | 79 | 110 | | 12 | |
| FSJ0241NB | 80*110*10 SC | | 80 | 110 | | 10 | |
| FSJ0241FB | 80*110*10 SC(VITON) | | 80 | 110 | | 10 | |
| FSJ0062NB | 80*110*10 TC | | 80 | 110 | | 10 | |
| FSJ0062FB | 80*110*10 TC(VITON) | | 80 | 110 | | 10 | |
| FSJ0001NB | 80*110*12 SB(Blue 2) | | 80 | 110 | | 12 | |
| FSJ0073NB | 80*110*12 TB | | 80 | 110 | | 12 | |
| FSJ0005NB | 80*110*12 TC | | 80 | 110 | | 12 | |
| FSJ0005FB | 80*110*12 TC(VITON) | | 80 | 110 | | 12 | |
| FSJ0136NB | 80*110*13 SC | | 80 | 110 | | 13 | |
| FSJ0074NB | 80*110*13 TC | | 80 | 110 | | 13 | |
| FSJ0074FB | 80*110*13 TC(VITON) | | 80 | 110 | | 13 | |
| FSJ0074QB | 80*110*13 TC(VMQ) | | 80 | 110 | | 13 | |
| FSJ0269NB | 82*110*12 SC | | 82 | 110 | | 12 | |
| FSJ0158NB | 82*110*12 TC | | 82 | 110 | | 12 | |
| FSJ0158FB | 82*110*12 TC(VITON) | | 82 | 110 | | 12 | |
| FSJ0077NB | 82*110*13 TC | | 82 | 110 | | 13 | |
| FSJ0215NB | 83*110*12 TC | | 83 | 110 | | 12 | |
| FSJ0271NB | 84*110*12 SB | | 84 | 110 | | 12 | |
| FSJ0228NB | 84*110*13 TB | | 84 | 110 | | 13 | |
| FSJ0222NB | 84*110*16 TC | | 84 | 110 | | 16 | |
| FSJ0230NB | 85*110*8 TC | | 85 | 110 | | 8 | |
| FSJ0130NB | 85*110*10 SC | | 85 | 110 | | 10 | |
| FSJ0086NB | 85*110*10 TC | | 85 | 110 | | 10 | |
| FSJ0086FB | 85*110*10 TC(VITON)FKM | | 85 | 110 | | 10 | |
| FSJ0182NB | 85*110*12 SC | | 85 | 110 | | 12 | |
| FSJ0182FB | 85*110*12 SC(VITON)FKM | | 85 | 110 | | 12 | |
| FSJ0249NB | 85*110*12 TB | | 85 | 110 | | 12 | |
| FSJ0003NB | 85*110*12 TC | | 85 | 110 | | 12 | |
| FSJ0003AB | 85*110*12 TC(ACM) | | 85 | 110 | | 12 | |

| WLK CODE | OIL SEALS | DESCRIPTION | ID | OD1 | OD2 | H1 | H2 |
|-----------|--------------------------|----------------------|----|-----|-----|-----|----|
| FSJ0003FB | 85*110*12 TC(FKM)VITON | | 85 | 110 | | 12 | |
| FSJ0127NB | 85*110*13 HTGR(VMQ) | | 85 | 110 | | 13 | |
| FSJ0248NB | 85*110*13 SB(VITON) | | 85 | 110 | | 13 | |
| FSJ0242FB | 85*110*13 SC(VITON) | | 85 | 110 | | 13 | |
| FSJ0229NB | 85*110*13 TB | | 85 | 110 | | 13 | |
| FSJ0048NB | 85*110*13 TC | MH-034102 | 85 | 110 | | 13 | |
| FSJ0048FB | 85*110*13 TC(VITON)FKM | | 85 | 110 | | 13 | |
| FSJ0048QB | 85*110*13 TC(VMQ) | | 85 | 110 | | 13 | |
| FSJ0144NB | 85*110/118*13 TC5 Brown | AE3842E | 85 | 110 | 118 | 13 | |
| FSJ0263FB | 85*110*15 TC(VITON) | | 85 | 110 | | 15 | |
| FSK0056NB | 88*110*12 TC | | 88 | 110 | | 12 | |
| FSK0205NB | 88*110*13 SC | | 88 | 110 | | 13 | |
| FSK0139NB | 88*110*13 TB | | 88 | 110 | | 13 | |
| FSK0071NB | 88*110*13 TC | | 88 | 110 | | 13 | |
| FSJ0164NB | 90*110*7 HTCL | | 90 | 110 | | 7 | |
| FSJ0256NB | 90*110*7 HTGL | | 90 | 110 | | 7 | |
| FSJ0175NB | 90*110*7.5 TC | | 90 | 110 | | 7.5 | |
| FSJ0175FB | 90*110*7.5 TC(VITON) | | 90 | 110 | | 7.5 | |
| FSJ0200NB | 90*110*8 TB | | 90 | 110 | | 8 | |
| FSJ0105NB | 90*110*8 TC | | 90 | 110 | | 8 | |
| FSJ0049NB | 90*110*8.5 HTCL | 90311-90002 | 90 | 110 | | 8.5 | |
| FSK0066NB | 90*110*8.5/10 HTC9L | 90311-90002/3 | 90 | 110 | | 8.5 | 10 |
| FSK0066QB | 90*110*8.5/10 HTC9L(VMQ) | G601-11-399黑色 | 90 | 110 | | 8.5 | 10 |
| FSJ0050NB | 90*110*9 HTCL | F802-11-399 | 90 | 110 | | 9 | |
| FSJ0101NB | 90*110*9 HTCL | | 90 | 110 | | 9 | |
| FSJ0050QB | 90*110*9 HTCL(VMQ) | F801-11-399 | 90 | 110 | | 9 | |
| FSJ0217NB | 90*110*10 HTCL | | 90 | 110 | | 10 | |
| FSJ0173NB | 90*110*10 SC | | 90 | 110 | | 10 | |
| FSJ0173FB | 90*110*10 SC(VITON) | | 90 | 110 | | 10 | |
| FSJ0100NB | 90*110*10 TC | | 90 | 110 | | 10 | |
| FSJ0100FB | 90*110*10 TC(VITON) | | 90 | 110 | | 10 | |
| FSJ0100QB | 90*110*10 TC(VMQ) | | 90 | 110 | | 10 | |
| FSJ0120NB | 90*110*10/11 HTB9L | 90311-90002(Brown)綠漆 | 90 | 110 | | 10 | 11 |
| FSJ0247FB | 90*110*11 TC(VITON) | | 90 | 110 | | 11 | |
| FSJ0052FB | 90*110*12 HTBCL(VITON) | | 90 | 110 | | 12 | |
| FSJ0052NB | 90*110*12 HTBL | 11 14 706 78A | 90 | 110 | | 12 | |
| FSJ0197NB | 90*110*12 HTCL | | 90 | 110 | | 12 | |
| FSJ0264FB | 90*110*12 SA(VITON) | | 90 | 110 | | 12 | |
| FSJ0093NB | 90*110*12 SC | | 90 | 110 | | 12 | |
| FSJ0093FB | 90*110*12 SC(VITON) | | 90 | 110 | | 12 | |
| FSJ0117NB | 90*110*12 TB | | 90 | 110 | | 12 | |
| FSJ0068NB | 90*110*12 TC | | 90 | 110 | | 12 | |
| FSJ0068FB | 90*110*12 TC(VITON) | | 90 | 110 | | 12 | |
| FSJ0260FB | 90*110*13 SB(VITON) | | 90 | 110 | | 13 | |
| FSJ0053NB | 90*110*13 TA | | 90 | 110 | | 13 | |
| FSJ0243NB | 90*110*13 TB | | 90 | 110 | | 13 | |
| FSJ0243FB | 90*110*13 TB(VITON) | | 90 | 110 | | 13 | |
| FSJ0069NB | 90*110*13 TC | | 90 | 110 | | 13 | |
| FSJ0069FB | 90*110*13 TC(VITON) | | 90 | 110 | | 13 | |
| FSJ0069QB | 90*110*13 TC(VMQ) | | 90 | 110 | | 13 | |
| FSJ260NB | 90*110/154*13 HTC5L | | 90 | 110 | 154 | 13 | |
| FSJ0167NB | 90*110*15 HTCL | | 90 | 110 | | 15 | |
| FSJ0189FB | 90*110*15 TC(VITON)FKM | | 90 | 110 | | 15 | |
| FSJ0202NB | 92*110*8.5 TC | | 92 | 110 | | 8.5 | |
| FSJ0202QB | 92*110*8.5 TC(VMQ) | | 92 | 110 | | 8.5 | |
| FSJ0054NB | 92*110*10 HSC | | 92 | 110 | | 10 | |
| FSJ0054QB | 92*110*10 HSC (VMQ) | | 92 | 110 | | 10 | |

| WLK CODE | OIL SEALS | DESCRIPTION | ID | OD1 | OD2 | H1 | H2 |
|-----------|---------------------------|---------------------------|-------|--------|-----|------|------|
| FSJ0114QB | 92*110*10 HTCL(VMQ) | | 92 | 110 | | 10 | |
| FSJ0084NB | 92*110*10 HTGL | | 92 | 110 | | 10 | |
| FSJ0084QB | 92*110*10 HTGL(VMQ) | 90311-92005 | 92 | 110 | | 10 | |
| FSJ0110NB | 92*110*10 TC | | 92 | 110 | | 10 | |
| FSJ0168NB | 92*110*12 TB | | 92 | 110 | | 12 | |
| FSJ0233NB | 95*110*7 TB | | 95 | 110 | | 7 | |
| FSJ0181NB | 95*110*9 TB | | 95 | 110 | | 9 | |
| FSJ0225NB | 95*110*9 TC | | 95 | 110 | | 9 | |
| FSJ0225FB | 95*110*9 TC(VITON) | | 95 | 110 | | 9 | |
| FSJ0147NB | 95*110*10 SC | | 95 | 110 | | 10 | |
| FSJ0055NB | 95*110*10 TB | | 95 | 110 | | 10 | |
| FSJ0161NB | 95*110*10 TC | | 95 | 110 | | 10 | |
| FSJ0161FB | 95*110*10 TC(VITON) | | 95 | 110 | | 10 | |
| FSJ0008NB | 95*110*11 HTCL | 90043-11076 | 95 | 110 | | 11 | |
| FSJ0162NB | 95*110*11 TC | | 95 | 110 | | 11 | |
| FSJ0214NB | 95*110*12 TC | | 95 | 110 | | 12 | |
| FSJ0214FB | 95*110*12 TC(VITON) | | 95 | 110 | | 12 | |
| FSJ0216NB | 95*110*13 SC | | 95 | 110 | | 13 | |
| FSJ0148NB | 95*110*13 TC | | 95 | 110 | | 13 | |
| FSJ0179AB | 98*110*8.5 HTCKL(ACM) | 11239 | 98 | 110 | | 8.5 | |
| FSN0016N0 | 150*110*12 X3 | | 150 | 110 | | 12 | |
| PMN0016C | 150*110*12 X3 (鐵殼) | WEAR RING | 150 | 110 | | 12 | |
| FSK0017NB | 85*111*10 TC | 40232-C0400 | 85 | 111 | | 10 | |
| FSK0074NB | 88.9*111*12.7 SC | | 88.9 | 111 | | 12.7 | |
| FSK0102NB | 91*111*9 HTCL | MD-101915 | 91 | 111 | | 9 | |
| FSK0102FB | 91*111*9 HTCL(VITON) | | 91 | 111 | | 9 | |
| FSK0102QB | 91*111*9 HTCL(VMQ) | | 91 | 111 | | 9 | |
| FSK9948NB | 88.9*111.12*9.52 SC | | 88.9 | 111.12 | | 9.52 | |
| FSK9976NB | 79.38*111.13*12.7 TA | | 79.38 | 111.13 | | 12.7 | |
| FSK9970NB | 82.55*111.13*9.53 TA | | 82.55 | 111.13 | | 9.53 | |
| FSK9995NB | 85.73*111.13*12.7 TA | | 85.73 | 111.13 | | 12.7 | |
| FSK9961NB | 85.73*111.13*12.7 TC | 3.375*4.375*0.50 TC | 85.73 | 111.13 | | 12.7 | |
| FSK9961FB | 85.73*111.13*12.7 TC(FKM) | 3.375*4.375*0.50 TC(VITO) | 85.73 | 111.13 | | 12.7 | |
| FSK9974NB | 88.9*111.13*9.53 TA | | 88.9 | 111.13 | | 9.53 | |
| FSK0048NB | 88.9*111.13*12.7 TC | | 88.9 | 111.13 | | 12.7 | |
| FSJ0056NB | 84.1*111.25*12.7 SC | | 84.1 | 111.25 | | 12.7 | |
| FSL0123NB | 52*112*10.5/15.5 SCY | | 52 | 112 | | 10.5 | 15.5 |
| FSK0008NB | 70*112*10/18 TB9(TB2Y) | MT-100138, MB-161152 | 70 | 112 | | 10 | 18 |
| FSK0122NB | 70*112*10/18.5 TB9 | | 70 | 112 | | 10 | 18.5 |
| FSK0082NB | 70*112*12 TC | | 70 | 112 | | 12 | |
| FSK0096NB | 70*112*13 TC | | 70 | 112 | | 13 | |
| FSK0009NB | 70*112*14/20 TB9(UDS-6S) | 90043-11053 WLK | 70 | 112 | | 14 | 20 |
| FSJ0121NB | 75*112*10/17.5 TAY | 1-09625-006-0(SPSA2) | 75 | 112 | | 10 | 17.5 |
| FSJ0255NB | 90*112*12 TC | | 90 | 112 | | 12 | |
| FSK0213NB | 95*112*12 TC | | 95 | 112 | | 12 | |
| FSK0226NB | 95*112*12.5 TC | | 95 | 112 | | 12.5 | |
| FSI1007NB | 100*112*9 TC | | 100 | 112 | | 9 | |
| FSK0023NB | 90*112.7*13 SA (Green) | | 90 | 112.7 | | 13 | |
| FSK0024NB | 90*112.7*13 TA | | 90 | 112.7 | | 13 | |
| FSK0217NB | 65*113*10/30 HTB9Y | | 65 | 113 | | 10 | 30 |
| FSJ0209NB | 78*113*13 SC | | 78 | 113 | | 13 | |
| FSK0030NB | 80*113*12/20 TAX4Y | 8-94336-316-0 | 80 | 113 | | 12 | 20 |
| FSK0094NB | 80*113*12/22 TAX4Y | 8-94367-958-0 | 80 | 113 | | 12 | 22 |
| FSK0112QB | 90*113*15 HTB5KY(VMQ) | ME-001195(6孔缺角) | 90 | 113 | | 15 | |
| FSK0163NB | 96*113/146*16 UDS-5S | | 96 | 113 | 146 | 16 | |
| FSJ0153NB | 56*114*10 Y | MB-308966 | 56 | 114 | | 10 | |

| WLK CODE | OIL SEALS | DESCRIPTION | ID | OD1 | OD2 | H1 | H2 |
|-----------|----------------------------------|------------------------|-------|--------|-----|-------|----|
| FSK0158NB | 60*114*12.5/29 TC9Y | N油封 | 60 | 114 | | 12.5 | 29 |
| FSK0029NB | 65*114*10/26 HTAWY | 9828-65113A(H3094) | 65 | 114 | | 10 | 26 |
| FSK0188NB | 88*114*12 TC | | 88 | 114 | | 12 | |
| FSK0180NB | 90*114*12 HTCL | | 90 | 114 | | 12 | |
| FSK0233NB | 91*114*9 TC | | 91 | 114 | | 9 | |
| FSK0189NB | 91*114*12 HTCL(BROWN) | ME-203250 | 91 | 114 | | 12 | |
| FSK0109Q0 | 92*114*9/17 KC5Y(VMQ) | 4936-Q5225(N油封)含毛氈 | 92 | 114 | | 9 | 17 |
| FSK0152Q0 | 93*114*8/17 Y(VMQ) | BZ5000(VMQ BLUE) | 93 | 114 | | 8 | 17 |
| FSK0106NB | 93*114*13 HTGL | 010 997 9047 | 93 | 114 | | 13 | |
| FSK0106QB | 93*114*13 HTGL(VMQ)Brown | 010 997 9047 | 93 | 114 | | 13 | |
| FSK0118NB | 94*114*5 SB | | 94 | 114 | | 5 | |
| FSK0028NB | 94*114*7 SM | | 94 | 114 | | 7 | |
| FSK0061NB | 94*114*7 SZ | (包腳) | 94 | 114 | | 7 | |
| FSK0114NB | 94*114*7 TZ | | 94 | 114 | | 7 | |
| FSK0127NB | 94*114*12 HTCL(BROWN) | | 94 | 114 | | 12 | |
| FSK0086NB | 94*114*12 TC | | 94 | 114 | | 12 | |
| FSK0101NB | 95*114*12 HTCL(BROWN) | BH5676E | 95 | 114 | | 12 | |
| FSK0101FB | 95*114*12 HTCL(FKM)VITON | ME-202851BH5676E | 95 | 114 | | 12 | |
| FSK0227NB | 97*114*12 TB | | 97 | 114 | | 12 | |
| FSK0067NB | 100*114*5 SZ | | 100 | 114 | | 5 | |
| FSK0032NB | 100*114*7 SB | | 100 | 114 | | 7 | |
| FSK0062NB | 100*114*7 SZ | (包腳) | 100 | 114 | | 7 | |
| FSK0115NB | 100*114*7 TZ | | 100 | 114 | | 7 | |
| FSK0068NB | 100*114*10 TC | | 100 | 114 | | 10 | |
| FSK0081NB | 100*114*12 TZ(TB) | 40227-Z5000 | 100 | 114 | | 12 | |
| FSK0033NB | 101*114*5 SB | | 101 | 114 | | 5 | |
| FSK0073NB | 101*114*10 TB(TZ) | 2445-6623-00 | 101 | 114 | | 10 | |
| FSK0027NB | 92.08*114.27*11.89 TA2 | 3.625*4.499*0.468 TA2 | 92.08 | 114.27 | | 11.89 | |
| FSK9953NB | 95.25*114.28*11.89 TA | | 95.25 | 114.28 | | 11.89 | |
| FSK9949NB | 74.63*114.3*11.91 TA | | 74.63 | 114.3 | | 11.91 | |
| FSK9997NB | 76.2*114.3*10.92 TA Red Painting | 3.00*4.50*0.43 TA紅漆 | 76.2 | 114.3 | | 10.92 | |
| FSK9990NB | 76.2*114.3*12 TA Red Painting | 415088 | 76.2 | 114.3 | | 12 | |
| FSK9985NB | 76.2*114.3*12.7 TC | | 76.2 | 114.3 | | 12.7 | |
| FSK9971NB | 79.38*114.3*12.7 TC | | 79.38 | 114.3 | | 12.7 | |
| FSK9988NB | 82.55*114.3*11.13 TA | | 82.55 | 114.3 | | 11.13 | |
| FSK9999NB | 82.55*114.3*12.7 TA | 3.25*4.50*0.50 TA | 82.55 | 114.3 | | 12.7 | |
| FSK9964NB | 82.55*114.3*12.7 TB | | 82.55 | 114.3 | | 12.7 | |
| FSK9963NB | 82.55*114.3*12.7 TC | 3.250*4.500*0.500 TC | 82.55 | 114.3 | | 12.7 | |
| FSK9973NB | 82.55*114.3*15.88 TA | | 82.55 | 114.3 | | 15.88 | |
| FSK0015NB | 84.3*114.3*15.8 SA | | 84.3 | 114.3 | | 15.8 | |
| FSK9969NB | 85.73*114.3*12.7 TC | 3.375*4.500*0.500 TC | 85.73 | 114.3 | | 12.7 | |
| FSK9982NB | 87.30*114.3*12.7 TA Red Painting | 3.437*4.500*0.500 TA紅漆 | 87.3 | 114.3 | | 12.7 | |
| FSK9957NB | 87.30*114.3*12.7 TC | 417492 | 87.3 | 114.3 | | 12.7 | |
| FSK9978NB | 87.31*114.3*12.7 SC | | 87.31 | 114.3 | | 12.7 | |
| FSK9980NB | 87.33*114.3*12.7 TC | | 87.33 | 114.3 | | 12.7 | |
| FSK9994NB | 88.9*114.3*9.53 SC | | 88.9 | 114.3 | | 9.53 | |
| FSK9962NB | 88.9*114.3*9.53 TB | | 88.9 | 114.3 | | 9.53 | |
| FSK9981NB | 88.9*114.3*9.53 TC | | 88.9 | 114.3 | | 9.53 | |
| FSK9952FB | 88.9*114.3*11.13 SA(FKM) | VITON | 88.9 | 114.3 | | 11.13 | |
| FSK9959NB | 88.9*114.3*11.13 SB | | 88.9 | 114.3 | | 11.13 | |
| FSK9979NB | 88.9*114.3*11.13 SC | | 88.9 | 114.3 | | 11.13 | |
| FSK9954NB | 88.9*114.3*11.13 TC | | 88.9 | 114.3 | | 11.13 | |
| FSK9956NB | 88.9*114.3*12.7 TB | | 88.9 | 114.3 | | 12.7 | |
| FSK0075NB | 88.9*114.3*12.7 TC | 3.500*4.500*0.500 TC | 88.9 | 114.3 | | 12.7 | |
| FSK9966NB | 92.07*114.3*12.7 SC | | 92.07 | 114.3 | | 12.7 | |
| FSK9951NB | 92.07*114.3*12.7 TC | | 92.07 | 114.3 | | 12.7 | |

| WLK CODE | OIL SEALS | DESCRIPTION | ID | OD1 | OD2 | H1 | H2 |
|-----------|-----------------------------------|------------------------|-------|--------|-----|-------|------|
| FSK9992NB | 92.08*114.3*12.7 SC | | 92.08 | 114.3 | | 12.7 | |
| FSK9991NB | 95.25*114.3*9.53 TC | | 95.25 | 114.3 | | 9.53 | |
| FSK9958NB | 95.25*114.3*11.13 TG | | 95.25 | 114.3 | | 11.13 | |
| FSK9965NB | 95.25*114.3*11.89 TA | | 95.25 | 114.3 | | 11.89 | |
| FSK9998NB | 95.25*114.3*11.89 TB | 3.750*4.500*0.468 TB | 95.25 | 114.3 | | 11.89 | |
| FSK9989NB | 95.25*114.3*11.91 TA | | 95.25 | 114.3 | | 11.91 | |
| FSK9967NB | 95.25*114.3*11.91 TB | | 95.25 | 114.3 | | 11.91 | |
| FSK9986NB | 95.25*114.3*12.7 TA | 3.750*4.500*0.500 TA | 95.25 | 114.3 | | 12.7 | |
| FSK9984NB | 95.25*114.3*12.7 TC | 3.750*4.500*0.500 TC | 95.25 | 114.3 | | 12.7 | |
| FSK0064NB | 87.30*114.33*9.53 TA Red Painting | 3.437*4.501*0.375 TA紅漆 | 87.3 | 114.33 | | 9.53 | |
| FSK9977NB | 88.9*114.33*11.89 TA Red Painting | 3.500*4.501*0.468 TA | 88.9 | 114.33 | | 11.89 | |
| FSK0168NB | 65*115*13 TC | | 65 | 115 | | 13 | |
| FSK0011NB | 70*115*12 TC | | 70 | 115 | | 12 | |
| FSK0121NB | 70*115*14 TC | | 70 | 115 | | 14 | |
| FSK0156NB | 70*115*15 TC | 38189-90005/2 | 70 | 115 | | 15 | |
| FSK0154NB | 75*115*10 SC | | 75 | 115 | | 10 | |
| FSK0135NB | 75*115*10 TC | | 75 | 115 | | 10 | |
| FSK0135FB | 75*115*10 TC(VITON) | | 75 | 115 | | 10 | |
| FSK0183NB | 75*115*12 TB | | 75 | 115 | | 12 | |
| FSK0098NB | 75*115*12 TC | | 75 | 115 | | 12 | |
| FSK0098FB | 75*115*12 TC(VITON) | | 75 | 115 | | 12 | |
| FSJ0165NB | 75*115*12/21 TAY(Y) | | 75 | 115 | | 12 | 21 |
| FSK0041NB | 75*115*13 TC | | 75 | 115 | | 13 | |
| FSK0041FB | 75*115*13 TC(VITON) | | 75 | 115 | | 13 | |
| FSK0171NB | 76*115*13/21 TAY | | 76 | 115 | | 13 | 21 |
| FSK0179NB | 78*115*10 TC | | 78 | 115 | | 10 | |
| FSK0228NB | 78*115*10/19.5 TAY | | 78 | 115 | | 10 | 19.5 |
| FSK0077NB | 78*115*14/20 TA29 | 90311-78001, AA3695E | 78 | 115 | | 14 | 20 |
| FSK0132NB | 80*115*6 VB2 | | 80 | 115 | | 6 | |
| FSK0123NB | 80*115*10 TC | | 80 | 115 | | 10 | |
| FSK0123FB | 80*115*10 TC(VITON) | | 80 | 115 | | 10 | |
| FSK0140NB | 80*115*12 SC | | 80 | 115 | | 12 | |
| FSK0138NB | 80*115*12 TC | | 80 | 115 | | 12 | |
| FSK0190NB | 80*115*13 SC | | 80 | 115 | | 13 | |
| FSK0042NB | 80*115*13 TC | | 80 | 115 | | 13 | |
| FSK0042FB | 80*115*13 TC(VITON) | | 80 | 115 | | 13 | |
| FSK0177NB | 80*115*15 TB | | 80 | 115 | | 15 | |
| FSK0159NB | 80*115*15 TC(BRWON) | | 80 | 115 | | 15 | |
| FSI0119NB | 85*115*12 TC | | 85 | 115 | | 12 | |
| FSI0119FB | 85*115*12 TC(VITON) | | 85 | 115 | | 12 | |
| FSK0001NB | 85*115*13 SA2 | | 85 | 115 | | 13 | |
| FSK0044NB | 85*115*13 TC | | 85 | 115 | | 13 | |
| FSK0044FB | 85*115*13 TC(VITON) | | 85 | 115 | | 13 | |
| FSI0239NB | 85*115*15 SC | | 85 | 115 | | 15 | |
| FSI0209NB | 85*115*15 TC | | 85 | 115 | | 15 | |
| FSK0178NB | 88*115*13 TB | | 88 | 115 | | 13 | |
| FSK0004NB | 88*115*13 TC | N22Y 曲軸, CRANK SHAFT | 88 | 115 | | 13 | |
| FSK0182NB | 90*115*9 SB | | 90 | 115 | | 9 | |
| FSK0100NB | 90*115*9 SC | | 90 | 115 | | 9 | |
| FSK0203NB | 90*115*9 TC | | 90 | 115 | | 9 | |
| FSK0049NB | 90*115*10 TC | | 90 | 115 | | 10 | |
| FSK0049FB | 90*115*10 TC(VITON) | | 90 | 115 | | 10 | |
| FSK0111NB | 90*115*11 TC | | 90 | 115 | | 11 | |
| FSK0108NB | 90*115*12 TC | | 90 | 115 | | 12 | |
| FSK0108FB | 90*115*12 TC(VITON) | | 90 | 115 | | 12 | |
| FSK0221FB | 90*115*12 TG(VITON) | | 90 | 115 | | 12 | |
| FSK0128NB | 90*115*13 DC | | 90 | 115 | | 13 | |

| WLK CODE | OIL SEALS | DESCRIPTION | ID | OD1 | OD2 | H1 | H2 |
|-----------|-----------------------------|-----------------------|-------|--------|-------|-------|----|
| FSK0125NB | 90*115*13 SB | | 90 | 115 | | 13 | |
| FSK0078NB | 90*115*13 TB | | 90 | 115 | | 13 | |
| FSK0025NB | 90*115*13 TC | 5/6 AHU THRUST SHAFT | 90 | 115 | | 13 | |
| FSK0025CB | 90*115*13 TC(neoprene) | CR70度黑色 | 90 | 115 | | 13 | |
| FSK0025FB | 90*115*13 TC(VITON) | | 90 | 115 | | 13 | |
| FSK0010NB | 90*115*13 TCN | AP3932B(NOK) | 90 | 115 | | 13 | |
| FSK0145NB | 90*115*13/19 HTZ9R | 9828-90104 | 90 | 115 | | 13 | 19 |
| FSK0129NB | 95*115*8.5 TC | | 95 | 115 | | 8.5 | |
| FSK0113QB | 95*115*9.5/12 HTB9L(N) | N油封含毛氈(VMQ) | 95 | 115 | | 9.5 | 12 |
| FSK0113NB | 95*115*9.5/12 HTBCKL W/Felt | | 95 | 115 | | 9.5 | 12 |
| FSK0006NB | 95*115*9.5/12 HTCL(HTC9L) | 90311-95008, T1278 | 95 | 115 | | 9.5 | 12 |
| FSK0084NB | 95*115*10 TC | | 95 | 115 | | 10 | |
| FSK0084FB | 95*115*10 TC(VITON) | | 95 | 115 | | 10 | |
| FSK0131NB | 95*115*12 HTCL | 90311-95001 | 95 | 115 | | 12 | |
| FSK0131FB | 95*115*12 HTCL(VITON) | | 95 | 115 | | 12 | |
| FSK0131QB | 95*115*12 HTCL(VMQ)(N) | N油封 | 95 | 115 | | 12 | |
| FSK1005NB | 95*115*12 TC | 90311-95001 | 95 | 115 | | 12 | |
| FSK1005CB | 95*115*12 TC(neoprene) | CR70度黑色 | 95 | 115 | | 12 | |
| FSK1005FB | 95*115*12 TC(VITON) | | 95 | 115 | | 12 | |
| FSK0026NB | 95*115*13 HTCL | | 95 | 115 | | 13 | |
| FSK0201NB | 95*115*13 SB | | 95 | 115 | | 13 | |
| FSK0155NB | 95*115*13 TC | | 95 | 115 | | 13 | |
| FSK0155FB | 95*115*13 TC(VITON) | | 95 | 115 | | 13 | |
| FSK0087NB | 100*115*9 TC | | 100 | 115 | | 9 | |
| FSK0212NB | 100*115*10 TC | | 100 | 115 | | 10 | |
| FSK0079NB | 100*115*12 TC | | 100 | 115 | | 12 | |
| FSK0079FB | 100*115*12 TC(VITON) | | 100 | 115 | | 12 | |
| FSK0150QB | 79*116/125.5*7.5/10HSG5L | R860011(VMQ)灰咖啡Grey B | 79 | 116 | 125.5 | 7.5 | 10 |
| FSL0127NB | 98*116*10 HTCL | 09283-98002 | 98 | 116 | | 10 | |
| FSL0127QB | 98*116*10 HTCL(VMQ) | | 98 | 116 | | 10 | |
| FSL0037NB | 98*116*10 TC | | 98 | 116 | | 10 | |
| FSL0145QB | 98*116*10 TC(VMQ) | | 98 | 116 | | 10 | |
| FSK0016NB | 101*116*8 HTCR | BH2201-E | 101 | 116 | | 8 | |
| FSK0095NB | 102*116*14 TB | | 102 | 116 | | 14 | |
| FSK0142NB | 102*116*14 TB3 | MH-034091 | 102 | 116 | | 14 | |
| FSK0231NB | 93*117*12 TC | | 93 | 117 | | 12 | |
| FSK9950NB | 82.55*117.48*11.13 SA | | 82.55 | 117.48 | | 11.13 | |
| FSK9987NB | 82.55*117.48*12.7 SB | | 82.55 | 117.48 | | 12.7 | |
| FSK9996NB | 82.55*117.48*12.7 TA | | 82.55 | 117.48 | | 12.7 | |
| FSK9960NB | 82.55*117.48*12.7 TB | | 82.55 | 117.48 | | 12.7 | |
| FSK9968NB | 85.73*117.48*9.53 SA | | 85.73 | 117.48 | | 9.53 | |
| FSK9975NB | 85.73*117.48*12.7 TA | | 85.73 | 117.48 | | 12.7 | |
| FSK9993NB | 88.9*117.48*12.7 TA | | 88.9 | 117.48 | | 12.7 | |
| FSK9972NB | 92.07*117.48*12.7 TC | | 92.07 | 117.48 | | 12.7 | |
| FSK0013NB | 83*118*9.5 SC | | 83 | 118 | | 9.5 | |
| FSK0003NB | 90*118*12 TA | TY42415-20540-71 | 90 | 118 | | 12 | |
| FSK0107NB | 90*118*12 TC | | 90 | 118 | | 12 | |
| FSK0031NB | 95*118*10 HTCL | 8-94214-913-0,4JB1 | 95 | 118 | | 10 | |
| FSK0031QB | 95*118*10 HTCL(VMQ) | | 95 | 118 | | 10 | |
| FSK0166QB | 95*118*10/13 Y(FELT+VMQ) | N油封(毛氈+鐵圈) | 95 | 118 | | 10 | 13 |
| FSK0110NB | 100*118*9 HTCKL W/Felt | | 100 | 118 | | 9 | |
| FSK0204NB | 100*118*10 TC | | 100 | 118 | | 10 | |
| FSK0207NB | 100*118*12 SB | | 100 | 118 | | 12 | |
| FSK0088NB | 100*118*12 TC | | 100 | 118 | | 12 | |
| FSK0065NB | 99*119*9.5 HTCL | TOYOTA LAND CRUISER | 99 | 119 | | 9.5 | |
| FSK0065QB | 99*119*9.5 HTCL (VMQ) | T1294 | 99 | 119 | | 9.5 | |

| WLK CODE | OIL SEALS | DESCRIPTION | ID | OD1 | OD2 | H1 | H2 |
|-----------|------------------------|-------------|----|-----|-----|----|----|
| FSK0229FB | 55*120*12 TC(VITON) | | 55 | 120 | | 12 | |
| FSK0162NB | 62*120*12 TC | | 62 | 120 | | 12 | |
| FSK0119NB | 65*120*10 TC | | 65 | 120 | | 10 | |
| FSK0120NB | 65*120*12 TC | | 65 | 120 | | 12 | |
| FSK0137NB | 65*120*13 TC | | 65 | 120 | | 13 | |
| FSK0175NB | 70*120*10 TA | | 70 | 120 | | 10 | |
| FSK0232NB | 70*120*10 TB | | 70 | 120 | | 10 | |
| FSK0097NB | 70*120*10 TC | | 70 | 120 | | 10 | |
| FSK0153NB | 70*120*12 TC | | 70 | 120 | | 12 | |
| FSK0153FB | 70*120*12 TC(VITON) | | 70 | 120 | | 12 | |
| FSK0141NB | 70*120*13 SC | | 70 | 120 | | 13 | |
| FSK0174NB | 70*120*13 TC | | 70 | 120 | | 13 | |
| FSK0181NB | 70*120*14 TC(BLUE) | | 70 | 120 | | 14 | |
| FSK0172NB | 75*120*10 TC | | 75 | 120 | | 10 | |
| FSK0172FB | 75*120*10 TC(VITON) | | 75 | 120 | | 10 | |
| FSK0164NB | 75*120*12 TC | | 75 | 120 | | 12 | |
| FSK0099NB | 75*120*13 TC | | 75 | 120 | | 13 | |
| FSK0099FB | 75*120*13 TC(VITON)FKM | | 75 | 120 | | 13 | |
| FSK0169NB | 80*120*10 TC | | 80 | 120 | | 10 | |
| FSK0134NB | 80*120*12 SA | | 80 | 120 | | 12 | |
| FSK0043NB | 80*120*12 TC | | 80 | 120 | | 12 | |
| FSK0147NB | 80*120*13 SC | | 80 | 120 | | 13 | |
| FSK0187NB | 80*120*13 TA | | 80 | 120 | | 13 | |
| FSK0069NB | 80*120*13 TC | | 80 | 120 | | 13 | |
| FSK0069FB | 80*120*13 TC(VITON) | | 80 | 120 | | 13 | |
| FSK0103NB | 85*120*10 TC | | 85 | 120 | | 10 | |
| FSK0093NB | 85*120*12 SC | | 85 | 120 | | 12 | |
| FSK0093FB | 85*120*12 SC(VITON) | | 85 | 120 | | 12 | |
| FSK0045NB | 85*120*12 TC | | 85 | 120 | | 12 | |
| FSK0045FB | 85*120*12 TC(VITON)FKM | | 85 | 120 | | 12 | |
| FSK0046NB | 85*120*13 TC | | 85 | 120 | | 13 | |
| FSK0046FB | 85*120*13 TC(VITON) | | 85 | 120 | | 13 | |
| FSK0105NB | 85*120*14 TC | | 85 | 120 | | 14 | |
| FSK0055NB | 85*120*15 TC | | 85 | 120 | | 15 | |
| FSK0200NB | 88*120*12 SC | | 88 | 120 | | 12 | |
| FSK0136NB | 88*120*13 TC | | 88 | 120 | | 13 | |
| FSK0146NB | 90*120*10 TC | | 90 | 120 | | 10 | |
| FSK0170NB | 90*120*12 SC | | 90 | 120 | | 12 | |
| FSK0170FB | 90*120*12 SC(VITON) | | 90 | 120 | | 12 | |
| FSK0176NB | 90*120*12 TA | | 90 | 120 | | 12 | |
| FSK0161NB | 90*120*12 TB | | 90 | 120 | | 12 | |
| FSK0063NB | 90*120*12 TC | | 90 | 120 | | 12 | |
| FSK0063FB | 90*120*12 TC(FKM)VITON | | 90 | 120 | | 12 | |
| FSK0063QB | 90*120*12 TC(VMQ) | | 90 | 120 | | 12 | |
| FSK0035NB | 90*120*13 SA | | 90 | 120 | | 13 | |
| FSK0143NB | 90*120*13 SC | | 90 | 120 | | 13 | |
| FSK0143FB | 90*120*13 SC(VITON) | TC型修掉副唇 | 90 | 120 | | 13 | |
| FSK0036NB | 90*120*13 TA2 | | 90 | 120 | | 13 | |
| FSK0151NB | 90*120*13 TB | | 90 | 120 | | 13 | |
| FSK0050NB | 90*120*13 TC | | 90 | 120 | | 13 | |
| FSK0050FB | 90*120*13 TC(VITON)FKM | | 90 | 120 | | 13 | |
| FSK0173NB | 90*120*15 SC | | 90 | 120 | | 15 | |
| FSK0186NB | 90*120*15 TC | | 90 | 120 | | 15 | |
| FSK0225NB | 90*120*17 Y | | 90 | 120 | | 17 | |
| FSK0130NB | 92*120*12 SC | | 92 | 120 | | 12 | |
| FSK0083NB | 92*120*12 TC | | 92 | 120 | | 12 | |
| FSK0220NB | 92*120*13 SC | | 92 | 120 | | 13 | |

| WLK CODE | OIL SEALS | DESCRIPTION | ID | OD1 | OD2 | H1 | H2 |
|-----------|---------------------------|-----------------------|-------|--------|-----|------|------|
| FSK0216NB | 92*120*13 TC | | 92 | 120 | | 13 | |
| FSK0216FB | 92*120*13 TC(VITON) | | 92 | 120 | | 13 | |
| FSK0126NB | 95*120*10 TC | | 95 | 120 | | 10 | |
| FSK0157NB | 95*120*12 HTCL(BROWN) | | 95 | 120 | | 12 | |
| FSK0215NB | 95*120*12 SC | | 95 | 120 | | 12 | |
| FSK0215FB | 95*120*12 SC(VITON) | TC修掉副唇 | 95 | 120 | | 12 | |
| FSK0234NB | 95*120*12 TB | | 95 | 120 | | 12 | |
| FSK0060NB | 95*120*12 TC | | 95 | 120 | | 12 | |
| FSK0060FB | 95*120*12 TC(VITON)FKM | | 95 | 120 | | 12 | |
| FSK0214FB | 95*120*12/12.5 TCV(FKM) | VITON | 95 | 120 | | 12 | 12.5 |
| FSK0039NB | 95*120*13 HTBL | | 95 | 120 | | 13 | |
| FSK0002NB | 95*120*13 SA | | 95 | 120 | | 13 | |
| FSK0040NB | 95*120*13 TC | ME-061853 | 95 | 120 | | 13 | |
| FSK0040FB | 95*120*13 TC(FKM)VITON | | 95 | 120 | | 13 | |
| FSK0040QB | 95*120*13 TC(VMQ) | | 95 | 120 | | 13 | |
| FSK0230FB | 95*120*15 TC(VITON) | | 95 | 120 | | 15 | |
| FSK0149NB | 97*120*13 TA | | 97 | 120 | | 13 | |
| FSK0116NB | 98*120*12 TC | | 98 | 120 | | 12 | |
| FSK0148NB | 98*120*13 SC | | 98 | 120 | | 13 | |
| FSK0085NB | 98*120*13 TC | | 98 | 120 | | 13 | |
| FSK0085FB | 98*120*13 TC(VITON) | | 98 | 120 | | 13 | |
| FSK0160NB | 100*120*8 TB | | 100 | 120 | | 8 | |
| FSK0206NB | 100*120*8 TC | | 100 | 120 | | 8 | |
| FSK0202NB | 100*120*10 SB | | 100 | 120 | | 10 | |
| FSK0133NB | 100*120*10 SC | | 100 | 120 | | 10 | |
| FSK0133FB | 100*120*10 SC(VITON) | | 100 | 120 | | 10 | |
| FSK0224NB | 100*120*10 TB | | 100 | 120 | | 10 | |
| FSK0089NB | 100*120*10 TC | | 100 | 120 | | 10 | |
| FSK0072NB | 100*120*11 SC | 90311-99065 | 100 | 120 | | 11 | |
| FSK0037NB | 100*120*11 TC | | 100 | 120 | | 11 | |
| FSK0037QB | 100*120*11 TC(VMQ) | | 100 | 120 | | 11 | |
| FSK0208FB | 100*120*12 SC(VITON) | | 100 | 120 | | 12 | |
| FSK0210NB | 100*120*12 TA | | 100 | 120 | | 12 | |
| FSK0080NB | 100*120*12 TB | | 100 | 120 | | 12 | |
| FSK0052NB | 100*120*12 TC | | 100 | 120 | | 12 | |
| FSK0052FB | 100*120*12 TC(VITON) | | 100 | 120 | | 12 | |
| FSK0219FB | 100*120*13 SC(VITON) | | 100 | 120 | | 13 | |
| FSK0209NB | 100*120*13 TA | | 100 | 120 | | 13 | |
| FSK0223NB | 100*120*13 TB | | 100 | 120 | | 13 | |
| FSK0038NB | 100*120*13 TC | | 100 | 120 | | 13 | |
| FSK0038FB | 100*120*13 TC(VITON) | | 100 | 120 | | 13 | |
| FSK0038QB | 100*120*13 TC(VMQ) | | 100 | 120 | | 13 | |
| FSK0117NB | 100*120*13/18 HTC9L Brown | 9828-00109 | 100 | 120 | | 13 | 18 |
| FSK0184NB | 100*120/158*15 Y(L) | 100X120X16 UDS-5同一個 | 100 | 120 | 158 | 15 | |
| FSK0057NB | 100*120*16 UDS-5S | ME-011731;ME-011754 | 100 | 120 | | 16 | |
| FSK0057QB | 100*120*16 UDS-5S (VMQ) | ME-011731/54, F4145 | 100 | 120 | | 16 | |
| FSK0185FB | 104*120*13 TC(VITON) | | 104 | 120 | | 13 | |
| FSK0167NB | 105*120*8 TC | | 105 | 120 | | 8 | |
| FSK0144NB | 105*120*11 HTCL | | 105 | 120 | | 11 | |
| FSK0005NB | 105*120*11 TC | 90311-99005 | 105 | 120 | | 11 | |
| FSK0104NB | 105*120*11 TCK W/Felt | BE3046E | 105 | 120 | | 11 | |
| FSK0076NB | 105*120*13 SC | | 105 | 120 | | 13 | |
| FSK0091NB | 65*120.5*10 SCS-S(SPOSB) | MH-034006;03442-13000 | 65 | 120.5 | | 10 | |
| FSL9973NB | 79.38*120.65*12.7 TC | | 79.38 | 120.65 | | 12.7 | |
| FSL0041NB | 87.10*120.65*12.7 SC | | 87.1 | 120.65 | | 12.7 | |
| FSL9964NB | 87.30*120.65*12.7 TC | | 87.3 | 120.65 | | 12.7 | |
| FSL9966NB | 87.33*120.65*12.7 TC | | 87.33 | 120.65 | | 12.7 | |

| WLK CODE | OIL SEALS | DESCRIPTION | ID | OD1 | OD2 | H1 | H2 |
|-----------|----------------------------|-------------------------|-------|--------|-----|-------|------|
| FSL9983NB | 87.33*120.65*14.3 TC | | 87.33 | 120.65 | | 14.3 | |
| FSL9992NB | 88.9*120.65*12.7 TC | | 88.9 | 120.65 | | 12.7 | |
| FSL9991NB | 88.9*120.65*15.87 SB | | 88.9 | 120.65 | | 15.87 | |
| FSL9994NB | 92.07*120.65*12.7 TC Brown | AE3963E | 92.07 | 120.65 | | 12.7 | |
| FSL9997NB | 95.25*120.65*9.53 TB | | 95.25 | 120.65 | | 9.53 | |
| FSL9978NB | 95.25*120.65*12.7 TA | | 95.25 | 120.65 | | 12.7 | |
| FSL9980NB | 95.25*120.65*12.7 TB | | 95.25 | 120.65 | | 12.7 | |
| FSL9999NB | 95.25*120.65*12.7 TC | 3.750*4.750*0.500 TC | 95.25 | 120.65 | | 12.7 | |
| FSL9996NB | 98.43*120.65*9.53 TA | | 98.43 | 120.65 | | 9.53 | |
| FSL0007NB | 75*121*12 TB | | 75 | 121 | | 12 | |
| FSL0005NB | 75*121*13 TB | 0600-26-154,W025-26-154 | 75 | 121 | | 13 | |
| FSL0049NB | 75*121*13 TC | | 75 | 121 | | 13 | |
| FSL0137NB | 75*121*13/23 TBY | | 75 | 121 | | 13 | 23 |
| FSL0097NB | 82*121*12/19 Y | | 82 | 121 | | 12 | 19 |
| FSL0052NB | 56*122*10.5 SCY | 1-09625-331-0 | 56 | 122 | | 10.5 | |
| FSL0038NB | 70*122*12/30 TAY | MH-034143 噴紅漆 | 70 | 122 | | 12 | 30 |
| FSL0134NB | 75*122*12 TB | | 75 | 122 | | 12 | |
| FSL0098NB | 75*122*13 TZ | | 75 | 122 | | 13 | |
| FSL0054NB | 80*122*10/18 TBY(TB9) | | 80 | 122 | | 10 | 18 |
| FSL0073NB | 88.9*122.99*22.96 Y | 3.500*4.842*0.904 SCOT1 | 88.9 | 122.99 | | 22.96 | |
| FSL0089NB | 106*123*11 TB3 | | 106 | 123 | | 11 | |
| FSL9988NB | 95.25*123.82*12.7 TA | 3.750*4.875*0.500 TA | 95.25 | 123.82 | | 12.7 | |
| FSL9965NB | 96.85*123.82*12.7 TC | | 96.85 | 123.82 | | 12.7 | |
| FSL9986NB | 101.6*123.82*14.3 TA | | 101.6 | 123.82 | | 14.3 | |
| FSL9975NB | 98.43*123.83*12.7 TC | | 98.43 | 123.83 | | 12.7 | |
| FSL0095NB | 57*124*13 TC3Y | 9828-57102/03 | 57 | 124 | | 13 | |
| FSL0125NB | 57*124*14.5/27 TCY | 57*124*14.5/27 | 57 | 124 | | 14.5 | 27 |
| FSL0039NB | 68*124*11.5/27 HTBWY(R) | 1-09625-017-0 | 68 | 124 | | 11.5 | 27 |
| FSL0033NB | 68*124*11.5/27 TBRY | 1-09625-017-0 | 68 | 124 | | 11.5 | 27 |
| FSL0030NB | 80*124*10/26 HTAWY | 9828-80111A | 80 | 124 | | 10 | 26 |
| FSL0114NB | 98*124*13 TA | | 98 | 124 | | 13 | |
| FSL0129NB | 100*124*12 HTGBL | | 100 | 124 | | 12 | |
| FSL0032NB | 100*124*12 UDS-5S | ME-011867 | 100 | 124 | | 12 | |
| FSL0032QB | 100*124*12/14.5 UDS-5S VMQ | ME-011867 RH SILICON | 100 | 124 | | 12 | 14.5 |
| FSL0113QB | 100*124/158*12.3 Y(VMQ) | BZ4603E | 100 | 124 | 158 | 12.3 | |
| FSL0012NB | 100*124*13 HTB2L | 116 997 02 46A | 100 | 124 | | 13 | |
| FSL0012AB | 100*124*13 HTB2L(ACM) | 116 997 02 46A | 100 | 124 | | 13 | |
| FSL0056QB | 100*124*14.5 UDS-5S(VMQ) | | 100 | 124 | | 14.5 | |
| FSL0109NB | 57*125*8/13.6 SCY | | 57 | 125 | | 8 | 13.6 |
| FSL0124NB | 70*125*10 TC | | 70 | 125 | | 10 | |
| FSL0062NB | 70*125*12 TC | | 70 | 125 | | 12 | |
| FSL0062FB | 70*125*12 TC(VITON) | | 70 | 125 | | 12 | |
| FSL0094NB | 75*125*12 SC | | 75 | 125 | | 12 | |
| FSL0117NB | 75*125*12 TC | | 75 | 125 | | 12 | |
| FSL0088NB | 78*125*10 TC | | 78 | 125 | | 10 | |
| FSL0071NB | 80*125*10 TC | | 80 | 125 | | 10 | |
| FSL0157FB | 80*125*12 SC(VITON) | | 80 | 125 | | 12 | |
| FSL0025NB | 80*125*12 TC | | 80 | 125 | | 12 | |
| FSL0025FB | 80*125*12 TC(VITON) | | 80 | 125 | | 12 | |
| FSL0008NB | 80*125*13 TC | LD-F OIL SEALS | 80 | 125 | | 13 | |
| FSL0008FB | 80*125*13 TC(VITON) | | 80 | 125 | | 13 | |
| FSL0067NB | 85*125*10 TB | | 85 | 125 | | 10 | |
| FSL0118NB | 85*125*12 TC | | 85 | 125 | | 12 | |
| FSL0153NB | 85*125*13 TA | | 85 | 125 | | 13 | |
| FSL0024NB | 85*125*13 TC | | 85 | 125 | | 13 | |
| FSL0055NB | 85*125*14 TC | 38189-90007 | 85 | 125 | | 14 | |
| FSL0060NB | 90*125*12 TC | | 90 | 125 | | 12 | |

| WLK CODE | OIL SEALS | DESCRIPTION | ID | OD1 | OD2 | H1 | H2 |
|-----------|---------------------------|--------------------------|-------|-----|-----|------|----|
| FSK0124NB | 90*125*13 SC | | 90 | 125 | | 13 | |
| FSK0218NB | 90*125*13 TB | | 90 | 125 | | 13 | |
| FSK0090NB | 90*125*13 TC | | 90 | 125 | | 13 | |
| FSK0090FB | 90*125*13 TC(VITON) | | 90 | 125 | | 13 | |
| FSK0165NB | 90*125*15 TB | | 90 | 125 | | 15 | |
| FSK0092NB | 90*125*15 TC | | 90 | 125 | | 15 | |
| FSK0092FB | 90*125*15 TC(VITON) | | 90 | 125 | | 15 | |
| FSL0147NB | 95*125*10 TC | | 95 | 125 | | 10 | |
| FSL0139NB | 95*125*12 SC | | 95 | 125 | | 12 | |
| FSL0139FB | 95*125*12 SC(VITON) | | 95 | 125 | | 12 | |
| FSL0009NB | 95*125*12 TC | | 95 | 125 | | 12 | |
| FSL0009FB | 95*125*12 TC(VITON) | | 95 | 125 | | 12 | |
| FSL0142NB | 95*125*13 SA | | 95 | 125 | | 13 | |
| FSL0023NB | 95*125*13 TC | | 95 | 125 | | 13 | |
| FSL0023FB | 95*125*13 TC(VITON) | | 95 | 125 | | 13 | |
| FSL0130NB | 95*125*15 SA | | 95 | 125 | | 15 | |
| FSL0156NB | 95*125*15 TC | | 95 | 125 | | 15 | |
| FSL0162NB | 98*125*12 TC | | 98 | 125 | | 12 | |
| FSL0149NB | 98*125*13 SA | | 98 | 125 | | 13 | |
| FSL0119NB | 98*125*13 TC | | 98 | 125 | | 13 | |
| FSL0061NB | 100*125*8 TC | | 100 | 125 | | 8 | |
| FSL0002NB | 100*125*8 VC | 并關5000/7000前擔輪 | 100 | 125 | | 8 | |
| FSL0092NB | 100*125*10 TC | | 100 | 125 | | 10 | |
| FSL0155NB | 100*125*11 TZ | | 100 | 125 | | 11 | |
| FSL0166FB | 100*125*12 SC(VITON) | | 100 | 125 | | 12 | |
| FSL0003NB | 100*125*12 TC | | 100 | 125 | | 12 | |
| FSL0003FB | 100*125*12 TC(VITON) | | 100 | 125 | | 12 | |
| FSL0135FB | 100*125*12 TZ(VITON) | | 100 | 125 | | 12 | |
| FSL0013NB | 100*125*12/14 TCY | | 100 | 125 | | 12 | 14 |
| FSL0070NB | 100*125*12.5 HTC5L | ME-031548 | 100 | 125 | | 12.5 | |
| FSL0070QB | 100*125*12.5 HTC5L(VMQ) | ME-031548 | 100 | 125 | | 12.5 | |
| FSL0075NB | 100*125*13 HTBCKL W/Felt | BROWN | 100 | 125 | | 13 | |
| FSL0031NB | 100*125*13 HTCL | BROWN | 100 | 125 | | 13 | |
| FSL0148FB | 100*125*13 SC(VITON) | | 100 | 125 | | 13 | |
| FSL0036NB | 100*125*13 TA | | 100 | 125 | | 13 | |
| FSL0081NB | 100*125*13 TB | | 100 | 125 | | 13 | |
| FSL0082NB | 100*125*13 TB4 | | 100 | 125 | | 13 | |
| FSL0001NB | 100*125*13 TC | 并關5000/7000前擔輪 | 100 | 125 | | 13 | |
| FSL0001FB | 100*125*13 TC(VITON) | | 100 | 125 | | 13 | |
| FSL0080NB | 100*125*13 TCN | | 100 | 125 | | 13 | |
| FRG00004N | 100*125*13.5/21 Y(KC59Y) | 92.8/119*125/130*13.5/21 | 100 | 125 | | 13.5 | 21 |
| FSL0037QB | 100*125*13.8/21 Y(VMQ)N | ME-060124(VMQ)藍色+毛氈 | 100 | 125 | | 13.8 | 21 |
| FSL0083QB | 101.5*125*13 Y VMQ W/Felt | N油封(咖啡色) HTCKL | 101.5 | 125 | | 13 | |
| FSL0035NB | 102*125*13 HTCL | SE08-11-399,136311399 | 102 | 125 | | 13 | |
| FSL0035QB | 102*125*13 HTCL (VMQ) | (VMQ) | 102 | 125 | | 13 | |
| FSL0069NB | 102*125*13 TB | | 102 | 125 | | 13 | |
| FSL0146NB | 104*125*10 SC | | 104 | 125 | | 10 | |
| FSL0046NB | 104*125*10 TC | | 104 | 125 | | 10 | |
| FSL0059NB | 105*125*9 TC(Brown) | | 105 | 125 | | 9 | |
| FSL0044NB | 105*125*11 HTCL | ME-031584 | 105 | 125 | | 11 | |
| FSL0086NB | 105*125*12 SC | | 105 | 125 | | 12 | |
| FSL0084NB | 105*125*12 TC | | 105 | 125 | | 12 | |
| FSL0101NB | 105*125*13 HTCL | TF01-11-399 | 105 | 125 | | 13 | |
| FSL0101QB | 105*125*13 HTCL(VMQ) | | 105 | 125 | | 13 | |
| FSL0167NB | 105*125*13 TB | | 105 | 125 | | 13 | |
| FSL0040NB | 105*125*13 TC | | 105 | 125 | | 13 | |
| FSL0104NB | 110*125*8 TB | | 110 | 125 | | 8 | |

| WLK CODE | OIL SEALS | DESCRIPTION | ID | OD1 | OD2 | H1 | H2 |
|-----------|--------------------------------|--------------------------|--------|-----|-----|-------|----|
| FSL0093NB | 110*125*9.5 TC | | 110 | 125 | | 9.5 | |
| FSL0133NB | 110*125*12 TC | | 110 | 125 | | 12 | |
| FSL0068NB | 110*125*13 SC | | 110 | 125 | | 13 | |
| FSL0015NB | 110*125*13 TC | | 110 | 125 | | 13 | |
| FSL0116NB | 115*125*7/10 GA | | 115 | 125 | | 7 | 10 |
| FSL0110NB | 88*126*12 SC | | 88 | 126 | | 12 | |
| FSL0014NB | 106*126*12 HTCL | 9828-01144, 9828-01167 | 106 | 126 | | 12 | |
| FSL0014QB | 106*126*12 HTCL(VMQ) | | 106 | 126 | | 12 | |
| FSL0103NB | 80*127*16/24 HTBW | 1-09625-119-0 (N油封) | 80 | 127 | | 16 | 24 |
| FSL0102NB | 85*127*13 Y NBR80 | MB-308965 | 85 | 127 | | 13 | |
| FSL9998NB | 85.73*127*11.91 TA | | 85.73 | 127 | | 11.91 | |
| FSL9971NB | 85.73*127*12.7 SC | | 85.73 | 127 | | 12.7 | |
| FSL0065NB | 86*127*16/24 HTBR9 | 1-09825-323-0(N油封) | 86 | 127 | | 16 | 24 |
| FSL9972NB | 88.9*127*11.13 TA Red Painting | | 88.9 | 127 | | 11.13 | |
| FSL9961NB | 88.9*127*11.91 SC | | 88.9 | 127 | | 11.91 | |
| FSL0138NB | 88.9*127*11.91 TA | | 88.9 | 127 | | 11.91 | |
| FSL0085NB | 88.9*127*12.7 TC | | 88.9 | 127 | | 12.7 | |
| FSK9955NB | 92.07*127*12.7 TA | | 92.07 | 127 | | 12.7 | |
| FSL9957NB | 92.07*127*12.7 TC | | 92.07 | 127 | | 12.7 | |
| FSL9976NB | 95.25*127*12.7 TA | | 95.25 | 127 | | 12.7 | |
| FSL9968NB | 95.25*127*12.7 TC | | 95.25 | 127 | | 12.7 | |
| FSL9982NB | 98.42*127*12.7 TC | | 98.42 | 127 | | 12.7 | |
| FSL9958NB | 98.43*127*12.7 SC | | 98.43 | 127 | | 12.7 | |
| FSL9981NB | 99.82*127*12.7 SC | | 99.82 | 127 | | 12.7 | |
| FSL0076NB | 100*127*10 TC | | 100 | 127 | | 10 | |
| FSL0111NB | 100*127*12 TC | | 100 | 127 | | 12 | |
| FSL0063NB | 100*127*13 SC | | 100 | 127 | | 13 | |
| FSL0150NB | 100*127*13 TA | | 100 | 127 | | 13 | |
| FSL0163NB | 100.03*127*12.7 TC | | 100.03 | 127 | | 12.7 | |
| FSL9969NB | 101.6*127*7.95 SA | | 101.6 | 127 | | 7.95 | |
| FSL9969FB | 101.6*127*7.95 SA(VITON) | VITON | 101.6 | 127 | | 7.95 | |
| FSL9962NB | 101.6*127*7.95 TB | | 101.6 | 127 | | 7.95 | |
| FSL9995NB | 101.6*127*9.52 TB | | 101.6 | 127 | | 9.52 | |
| FSL9963NB | 101.6*127*9.53 TC | | 101.6 | 127 | | 9.53 | |
| FSL9963FB | 101.6*127*9.53 TC(VITON) | | 101.6 | 127 | | 9.53 | |
| FSL9989NB | 101.6*127*11.13 SA | | 101.6 | 127 | | 11.13 | |
| FSL9960FB | 101.6*127*11.13 TC(FKM) | VITON | 101.6 | 127 | | 11.13 | |
| FSL9979NB | 101.6*127*11.89 SA | | 101.6 | 127 | | 11.89 | |
| FSL9974NB | 101.6*127*12.7 SA | | 101.6 | 127 | | 12.7 | |
| FSL9993NB | 101.6*127*12.7 SC | 4.00*5.00*0.50 SC | 101.6 | 127 | | 12.7 | |
| FSL9970NB | 101.6*127*12.7 TA | 4.00*5.00*0.50 TA | 101.6 | 127 | | 12.7 | |
| FSL0026NB | 101.6*127*12.7 TC | 4.00*5.00*0.50 TC | 101.6 | 127 | | 12.7 | |
| FSL0026FB | 101.6*127*12.7 TC(VITON) | 4.00*5.00*0.50 TC(VITON) | 101.6 | 127 | | 12.7 | |
| FSL9959NB | 104.78*127*12.7 SC | | 104.78 | 127 | | 12.7 | |
| FSL9990NB | 104.78*127*14.3 SA | | 104.78 | 127 | | 14.3 | |
| FSL0050NB | 106.36*127*15.8 TC | | 106.36 | 127 | | 15.8 | |
| FSL9984NB | 106.38*127*9.53 TA | | 106.38 | 127 | | 9.53 | |
| FSL9977NB | 107.95*127*12.7 TB | | 107.95 | 127 | | 12.7 | |
| FSL0057NB | 85*128*11/21 SPSA29 | 1-09625-129-0 | 85 | 128 | | 11 | 21 |
| FSL0151NB | 95*128*12 TA | | 95 | 128 | | 12 | |
| FSL0128NB | 110*128*9 SA | | 110 | 128 | | 9 | |
| FSL0064NB | 110*128*9 SB | | 110 | 128 | | 9 | |
| FSL0165NB | 60*130*10 TC | | 60 | 130 | | 10 | |
| FSL0100NB | 70*130*12 TC | | 70 | 130 | | 12 | |
| FSL0100FB | 70*130*12 TC(VITON) | | 70 | 130 | | 12 | |
| FSL0122NB | 75*130*12 SC | | 75 | 130 | | 12 | |
| FSL0120NB | 75*130*13 TC | | 75 | 130 | | 13 | |

| WLK CODE | OIL SEALS | DESCRIPTION | ID | OD1 | OD2 | H1 | H2 |
|-----------|-------------------------|-------------|-----|-----|-----|------|------|
| FSM0157NB | 80*130*12 TC | | 80 | 130 | | 12 | |
| FSM0059NB | 80*130*13 SC | | 80 | 130 | | 13 | |
| FSM0040NB | 80*130*13 TC | | 80 | 130 | | 13 | |
| FSM0040FB | 80*130*13 TC(VITON) | | 80 | 130 | | 13 | |
| FSK0211NB | 85*130*10 TC | | 85 | 130 | | 10 | |
| FSK0058NB | 85*130*12 TC | | 85 | 130 | | 12 | |
| FSK0058FB | 85*130*12 TC(VITON) | | 85 | 130 | | 12 | |
| FSK0059NB | 85*130*13 TC | | 85 | 130 | | 13 | |
| FSL0121NB | 90*130*10 TC | | 90 | 130 | | 10 | |
| FSL0096NB | 90*130*12 SC | | 90 | 130 | | 12 | |
| FSL0107NB | 90*130*12 TC | | 90 | 130 | | 12 | |
| FSL0107FB | 90*130*12 TC(VITON) | | 90 | 130 | | 12 | |
| FSL0017NB | 90*130*12.7 SC | | 90 | 130 | | 12.7 | |
| FSM0119FB | 90*130*13 SC(VITON) | TC型修掉副唇 | 90 | 130 | | 13 | |
| FSM0048NB | 90*130*13 TA | | 90 | 130 | | 13 | |
| FSM0042NB | 90*130*13 TC | | 90 | 130 | | 13 | |
| FSM0042FB | 90*130*13 TC(VITON) | | 90 | 130 | | 13 | |
| FSM0042QB | 90*130*13 TC(VMQ) | | 90 | 130 | | 13 | |
| FSL0079NB | 90*130*15 TC | | 90 | 130 | | 15 | |
| FSL0090NB | 95*130*10 TC | | 95 | 130 | | 10 | |
| FSL0078NB | 95*130*12 TC | | 95 | 130 | | 12 | |
| FSL0078FB | 95*130*12 TC(VITON) | | 95 | 130 | | 12 | |
| FSL0072NB | 95*130*12/17.5 TCY | | 95 | 130 | | 12 | 17.5 |
| FSL0004NB | 95*130*13 SA2 | | 95 | 130 | | 13 | |
| FSL0144NB | 95*130*13 TB | | 95 | 130 | | 13 | |
| FSL0042NB | 95*130*13 TC | | 95 | 130 | | 13 | |
| FSL0108NB | 95*130*15 SC | | 95 | 130 | | 15 | |
| FSL0010NB | 95*130*15 TC(Brown) | | 95 | 130 | | 15 | |
| FSL0169NB | 97*130*13 TA | | 97 | 130 | | 13 | |
| FSL0066NB | 98*130*12 TA | | 98 | 130 | | 12 | |
| FSL0136NB | 98*130*12 TC(BROWN) | | 98 | 130 | | 12 | |
| FSL0048NB | 98*130*13 TB | | 98 | 130 | | 13 | |
| FSL0087NB | 100*130*8 SB | | 100 | 130 | | 8 | |
| FSL0077NB | 100*130*10 TC | | 100 | 130 | | 10 | |
| FSL0047NB | 100*130*12 SC | | 100 | 130 | | 12 | |
| FSL0047FB | 100*130*12 SC(VITON) | | 100 | 130 | | 12 | |
| FSL0112NB | 100*130*12 TB | | 100 | 130 | | 12 | |
| FSL0045NB | 100*130*12 TC | | 100 | 130 | | 12 | |
| FSL0045FB | 100*130*12 TC(VITON) | | 100 | 130 | | 12 | |
| FSL0019NB | 100*130*13 TC | | 100 | 130 | | 13 | |
| FSL0019FB | 100*130*13 TC(VITON) | | 100 | 130 | | 13 | |
| FSL0019QB | 100*130*13 TC(VMQ) | | 100 | 130 | | 13 | |
| FSL0154NB | 100*130*14 SC | | 100 | 130 | | 14 | |
| FSL0143NB | 100*130*14 TC | | 100 | 130 | | 14 | |
| FSL0143FB | 100*130*14 TC(VITON) | | 100 | 130 | | 14 | |
| FSL0016NB | 100*130*15 TB | | 100 | 130 | | 15 | |
| FSL0074NB | 100*130*15 TC | | 100 | 130 | | 15 | |
| FSL0164NB | 100*130*16 SA | | 100 | 130 | | 16 | |
| FSL0131NB | 102*130*13 TC | | 102 | 130 | | 13 | |
| FSL0161NB | 105*130*7.5/8 TCV | | 105 | 130 | | 7.5 | 8 |
| FSL0135NB | 105*130*10 TC(BROWN) | | 105 | 130 | | 10 | |
| FSL0126FB | 105*130*12 SC(VITON) | | 105 | 130 | | 12 | |
| FSL0168NB | 105*130*12 TA(VITON) | | 105 | 130 | | 12 | |
| FSL0027NB | 105*130*12 TC | | 105 | 130 | | 12 | |
| FSL0027FB | 105*130*12 TC(VITON)FKM | | 105 | 130 | | 12 | |
| FSL0058NB | 105*130*13 SC | | 105 | 130 | | 13 | |
| FSL0091NB | 105*130*13 TA | | 105 | 130 | | 13 | |

| WLK CODE | OIL SEALS | DESCRIPTION | ID | OD1 | OD2 | H1 | H2 |
|------------|----------------------------|-------------------------|--------|--------|-----|-------|------|
| FSL0028NB | 105*130*13 TC | | 105 | 130 | | 13 | |
| FSL0028FB | 105*130*13 TC(VITON)FKM | | 105 | 130 | | 13 | |
| FSL0034NB | 105*130*14 TC Brown | | 105 | 130 | | 14 | |
| FSL0053NB | 105*130*15 SA | | 105 | 130 | | 15 | |
| FSL0132NB | 105*130*15 TA | | 105 | 130 | | 15 | |
| FSL0158NB | 105*130*15 TC | | 105 | 130 | | 15 | |
| FSL0115NB | 107*130*13 TC | | 107 | 130 | | 13 | |
| FSL0152NB | 110*130*10 SC | | 110 | 130 | | 10 | |
| FSL0106NB | 110*130*10 TC | | 110 | 130 | | 10 | |
| FSL0160NB | 110*130*12 SA | | 110 | 130 | | 12 | |
| FSL0020NB | 110*130*12 TC | | 110 | 130 | | 12 | |
| FSL0020FB | 110*130*12 TC(VITON)FKM | | 110 | 130 | | 12 | |
| FSL0051QB | 110*130*13 HTGL(VMQ) | | 110 | 130 | | 13 | |
| FSL0141NB | 110*130*13 SA | | 110 | 130 | | 13 | |
| FSL0011NB | 110*130*13 TC | | 110 | 130 | | 13 | |
| FSL0011FB | 110*130*13 TC(FKM)VITON | | 110 | 130 | | 13 | |
| FSL0011QB | 110*130*13 TC(VMQ) | | 110 | 130 | | 13 | |
| FSL0140NB | 110*130*13 TM | | 110 | 130 | | 13 | |
| FSL0105NB | 115*130*12 TC | | 115 | 130 | | 12 | |
| FSL0105FB | 115*130*12 TC(VITON) | | 115 | 130 | | 12 | |
| FSL0099NB | 115*130*13 TC | | 115 | 130 | | 13 | |
| FSL9967NB | 93.68*130.17*12.7 TC | | 93.68 | 130.17 | | 12.7 | |
| FSM9991NB | 98.43*130.17*12.7 TA | | 98.43 | 130.17 | | 12.7 | |
| FSM9983NB | 101.6*130.17*14.3 TA | | 101.6 | 130.17 | | 14.3 | |
| FSM0005NB | 98.4*130.18*6.35/21.5TAY | 3.875*5.125*0.25/847TAY | 98.4 | 130.18 | | 6.35 | 21.5 |
| FSM9969NB | 101.6*130.18*12.7 TC | | 101.6 | 130.18 | | 12.7 | |
| FSM9972NB | 104.78*130.18*12.7 TC | | 104.78 | 130.18 | | 12.7 | |
| FSM0110NB | 70*132*12/30 TA9Y | | 70 | 132 | | 12 | 30 |
| FSM0056NB | 95*132*12/21.5 TAY | 1-09625-043-0 | 95 | 132 | | 12 | 21.5 |
| FSM0112NB | 100*132*13 TC | | 100 | 132 | | 13 | |
| FSMM0120FB | 112*132*7.5 SC(VITON) | | 112 | 132 | | 7.5 | |
| FSM0069FB | 112*132*7.5 TC(VITON) | FKM(VITON) | 112 | 132 | | 7.5 | |
| FSM0061NB | 116*132*12 TC | | 116 | 132 | | 12 | |
| FSM0060NB | 116*132*12 TC3(BROWN) | 2310-6850-20 | 116 | 132 | | 12 | |
| FSM0066NB | 64*132.5*13 TCY | 64*132.5*13 SPT3CS | 64 | 132.5 | | 13 | |
| FSM9997NB | 88.9*133.35*11.13 SA | | 88.9 | 133.35 | | 11.13 | |
| FSM9961NB | 95.25*133.35*12.7 SC | | 95.25 | 133.35 | | 12.7 | |
| FSM9987NB | 95.25*133.35*12.7 TA | 3.750*5.250*0.500 TA | 95.25 | 133.35 | | 12.7 | |
| FSM9989NB | 101.6*133.35*12.7 TA | | 101.6 | 133.35 | | 12.7 | |
| FSM9996NB | 101.6*133.35*12.7 TC | | 101.6 | 133.35 | | 12.7 | |
| FSM9967NB | 104.78*133.35*12.7 TA | | 104.78 | 133.35 | | 12.7 | |
| FSM9971NB | 106.38*133.35*12.7 SC | | 106.38 | 133.35 | | 12.7 | |
| FSM9970NB | 107.95*133.35*9.53 TA | | 107.95 | 133.35 | | 9.53 | |
| FSM9982NB | 107.95*133.35*11.13 SC | | 107.95 | 133.35 | | 11.13 | |
| FSM9964FB | 107.95*133.35*12.7 SC(FKM) | VITON(FKM) | 107.95 | 133.35 | | 12.7 | |
| FSM9992NB | 107.95*133.35*12.7 TC | | 107.95 | 133.35 | | 12.7 | |
| FSM9995FB | 107.95*133.35*14.3 TA(FKM) | FKM(VITON) | 107.95 | 133.35 | | 14.3 | |
| FSM9976NB | 114.3*133.35*9.53 SC | | 114.3 | 133.35 | | 9.53 | |
| FSM9966NB | 114.3*133.35*11.13 SB | | 114.3 | 133.35 | | 11.13 | |
| FSM9985NB | 114.3*133.35*11.13 SC | | 114.3 | 133.35 | | 11.13 | |
| FSM0098NB | 66*134*16 Y | 9828-66105 | 66 | 134 | | 16 | |
| FSM0129NB | 70*135*12 SC | | 70 | 135 | | 12 | |
| FSM0129FB | 70*135*12 SC(VITON) | | 70 | 135 | | 12 | |
| FSM0115NB | 80*135*12 HTBW | | 80 | 135 | | 12 | |
| FSM0002NB | 80*135*12/26 TCY(TC9) | 38189-90016, N2161 | 80 | 135 | | 12 | 26 |
| FSM0138NB | 80*135/146*15/26 HTBR59 | 38189-90018 | 80 | 135 | 146 | 15 | 26 |
| FSM0079NB | 85*135*12 TC | | 85 | 135 | | 12 | |

| WLK CODE | OIL SEALS | DESCRIPTION | ID | OD1 | OD2 | H1 | H2 |
|-----------|------------------------------|--------------------------|-----|-----|-----|------|------|
| FSM0122NB | 90*135*13 TA | | 90 | 135 | | 13 | |
| FSM0036NB | 90*135*13 TC | | 90 | 135 | | 13 | |
| FSM0028NB | 90*135*15 TA | W029-26-154 | 90 | 135 | | 15 | |
| FSM0076NB | 90*135*15 TC | | 90 | 135 | | 15 | |
| FSL0022NB | 95*135*13 TC | 43090-90016 | 95 | 135 | | 13 | |
| FSM0044NB | 100*135*10 HTCL | 1-09625-320-0 | 100 | 135 | | 10 | |
| FSM0044FB | 100*135*10 HTCL(VITON) | | 100 | 135 | | 10 | |
| FSM0044QB | 100*135*10 HTCL(VMQ) | | 100 | 135 | | 10 | |
| FSM0154NB | 100*135*10 TC | | 100 | 135 | | 10 | |
| FSM0015NB | 100*135*12 TC | | 100 | 135 | | 12 | |
| FSM0057NB | 100*135*13 TC | | 100 | 135 | | 13 | |
| FSM0057FB | 100*135*13 TC(VITON) | | 100 | 135 | | 13 | |
| FSM0080NB | 100*135*14 HTCL | 1-09625-402-0 | 100 | 135 | | 14 | |
| FSM0137NB | 100*135*14 TC | | 100 | 135 | | 14 | |
| FSM0078QB | 100*135/140*14 HTC5L(VMQ) | 8-09625-052-0(N油封) | 100 | 135 | 140 | 14 | |
| FSM0125NB | 100*135*15 TB | | 100 | 135 | | 15 | |
| FSM0095NB | 100*135*15 TC | | 100 | 135 | | 15 | |
| FSM0095FB | 100*135*15 TC(VITON) | | 100 | 135 | | 15 | |
| FSM0090QB | 100*135/140*15 HTC5L VMQ | 5-09625-014-1 N油 | 100 | 135 | 140 | 15 | |
| FSM0070QB | 105*135*9 HTG(VMQ) Gray | 12279-Z5500 | 105 | 135 | | 9 | |
| FSM0144NB | 105*135*10 SB | | 105 | 135 | | 10 | |
| FSM0144FB | 105*135*10 SB(VITON) | | 105 | 135 | | 10 | |
| FSM0037NB | 105*135*12 TC | | 105 | 135 | | 12 | |
| FSM0037FB | 105*135*12 TC(VITON) | | 105 | 135 | | 12 | |
| FSM0046NB | 105*135*12.5 HTCL | | 105 | 135 | | 12.5 | |
| FSM0111QB | 105*135*13 HTC5(VMQ) | 6130-21-4231 | 105 | 135 | | 13 | |
| FSM0100NB | 105*135*13 TB | | 105 | 135 | | 13 | |
| FSM0018NB | 105*135*13 TC | | 105 | 135 | | 13 | |
| FSM0018FB | 105*135*13 TC(VITON) | | 105 | 135 | | 13 | |
| FSM0003NB | 105*135*14 HTCL(BROWN) | 9099243580,1-09625-384-0 | 105 | 135 | | 14 | |
| FSM0092NB | 105*135*14 SC | | 105 | 135 | | 14 | |
| FSM0004NB | 105*135*14 TC | 1-09625-112-0 | 105 | 135 | | 14 | |
| FSM0004FB | 105*135*14 TC(VITON) | | 105 | 135 | | 14 | |
| FSM0099NB | 105*135*14 TCN | | 105 | 135 | | 14 | |
| FSM0091NB | 105*135*14/20.5 HTC9R Brown | 38189-90101 | 105 | 135 | | 14 | 20.5 |
| FSM0073QB | 105*135*14.7 HTBCKL(VMQ) | 咖啡色+黑色羊毛氈無商標 | 105 | 135 | | 14.7 | |
| FSM0073NB | 105*135*14.7 HTCKL W/Felt | 909924-4330 | 105 | 135 | | 14.7 | |
| FSM0038NB | 105*135*15 TC | | 105 | 135 | | 15 | |
| FSM0038FB | 105*135*15 TC(VITON)FKM | | 105 | 135 | | 15 | |
| FSM0029NB | 105*135*18 DB Green Painting | 6130-21-4231無商標 | 105 | 135 | | 18 | |
| FSM0031NB | 110*135*9 HTCL | 12279-Z5503 | 110 | 135 | | 9 | |
| FSM0031QB | 110*135*9 HTCL(VMQ) | BH2619E(VMQ) | 110 | 135 | | 9 | |
| FSM0142NB | 110*135*10 TC | | 110 | 135 | | 10 | |
| FSM0039NB | 110*135*12 TC | | 110 | 135 | | 12 | |
| FSM0039FB | 110*135*12 TC(VITON) | | 110 | 135 | | 12 | |
| FSM0001NB | 110*135*13 HTBL | | 110 | 135 | | 13 | |
| FSM0088NB | 110*135*13 HTGBL | | 110 | 135 | | 13 | |
| FSM0019NB | 110*135*13 TC | | 110 | 135 | | 13 | |
| FSM0019FB | 110*135*13 TC(VITON) | | 110 | 135 | | 13 | |
| FSM0146NB | 110*135*13 TZ | | 110 | 135 | | 13 | |
| FSM0109NB | 110*135*14 TC | | 110 | 135 | | 14 | |
| FSM0124NB | 110*135*15 TC | | 110 | 135 | | 15 | |
| FSM0156NB | 114*135*12 TC | | 114 | 135 | | 12 | |
| FSM0009NB | 114*135*13 HTBL | | 114 | 135 | | 13 | |
| FSM0158NB | 114*135*13 TB | | 114 | 135 | | 13 | |
| FSM0075NB | 114*135*13 TC | | 114 | 135 | | 13 | |

| WLK CODE | OIL SEALS | DESCRIPTION | ID | OD1 | OD2 | H1 | H2 |
|-----------|----------------------------|------------------------|--------|---------|-----|-------|------|
| FSM0085NB | 115*135*10 SC | | 115 | 135 | | 10 | |
| FSM0071NB | 115*135/144*10 HTC5L | NS FD6 CRANKSHAFT REAR | 115 | 135 | 144 | 10 | |
| FSM0063NB | 115*135*12 TC | | 115 | 135 | | 12 | |
| FSM0030NB | 115*135*13 SC | | 115 | 135 | | 13 | |
| FSM0113NB | 120*135*12 SC | | 120 | 135 | | 12 | |
| FSM0006NB | 80*136*10/26 HTAWY | 9828-80110A | 80 | 136 | | 10 | 26 |
| FSM0118NB | 95*136*13 SC | | 95 | 136 | | 13 | |
| FSM0150NB | 105*136*13 TC | | 105 | 136 | | 13 | |
| FSM0121NB | 110*136/165*12.5/26.5 SA2Y | BA2784E | 110 | 136 | 165 | 12.5 | 26.5 |
| FSM9962NB | 107.95*136.52*12.7 SC | | 107.95 | 136.52 | | 12.7 | |
| FSM9959NB | 107.95*136.52*12.7 TC | | 107.95 | 136.52 | | 12.7 | |
| FSM0033NB | 98.425*136.525*12.7 TB | 3.875*5.375*0.500 TB | 98.425 | 136.525 | | 12.7 | |
| FSM9968NB | 98.43*136.53*12.7 TA | | 98.43 | 136.53 | | 12.7 | |
| FSM9986NB | 98.43*136.53*12.7 TB | | 98.43 | 136.53 | | 12.7 | |
| FSM9981NB | 100.03*136.53*12.7 TA | 3.938*5.375*0.50 TA | 100.03 | 136.53 | | 12.7 | |
| FSM9999NB | 100.03*136.53*12.7 TB6 | 3.938*5.375*0.50 TB6 | 100.03 | 136.53 | | 12.7 | |
| FSM9990NB | 101.6*136.53*12.7 TA | | 101.6 | 136.53 | | 12.7 | |
| FSM9973NB | 109.55*136.53*12.7 TA | | 109.55 | 136.53 | | 12.7 | |
| FSM9975NB | 111.13*136.53*12.7 TC | | 111.13 | 136.53 | | 12.7 | |
| FSM0130NB | 95*137/175*12/29 HTG9RY | CR58709 | 95 | 137 | 175 | 12 | 29 |
| FSM0096QB | 104*137*13 Y(W/sleeve)VMQ | 含毛氈VMQ | 104 | 137 | | 13 | |
| FSM0131NB | 109*137*13 TC | | 109 | 137 | | 13 | |
| FSM0131QB | 109*137*13 TC(VMQ) Brown | 内径要求106.9+/-0.30 | 109 | 137 | | 13 | |
| FSM0094N0 | 109*137*13 Y(W/sleeve) VMQ | 8-97329-780-0 | 109 | 137 | | 13 | |
| FSM0055NB | 80*138*41 TB | | 80 | 138 | | 41 | |
| FSM0047NB | 122*138*12 TC | | 122 | 138 | | 12 | |
| FSM0132NB | 104*139*13 TC | | 104 | 139 | | 13 | |
| FSM0132QB | 104*139*13 TC(VMQ) Brown | 内径要求101.9+/-0.30 | 104 | 139 | | 13 | |
| FSM0086QB | 104*139*13 Y VMQ W/Felt | 8-97370-637-0 | 104 | 139 | | 13 | |
| FSM9988NB | 88.9*139.7*12.7 TA | | 88.9 | 139.7 | | 12.7 | |
| FSM9960NB | 101.6*139.7*12.7 SC | | 101.6 | 139.7 | | 12.7 | |
| FSM9979NB | 101.6*139.7*12.7 TC | | 101.6 | 139.7 | | 12.7 | |
| FSM9965NB | 107.95*139.7*12.7 TC | | 107.95 | 139.7 | | 12.7 | |
| FSM9977NB | 107.95*139.7*19.05 TC | | 107.95 | 139.7 | | 19.05 | |
| FSM9994NB | 109.55*139.7*14.30 TA | | 109.55 | 139.7 | | 14.3 | |
| FSM9963NB | 111.13*139.7*12.7 TB | | 111.13 | 139.7 | | 12.7 | |
| FSM9974NB | 114.3*139.7*12.7 SC | | 114.3 | 139.7 | | 12.7 | |
| FSM9978NB | 114.3*139.7*12.7 TA | | 114.3 | 139.7 | | 12.7 | |
| FSM9978FB | 114.3*139.7*12.7 TA(FKM) | VITON | 114.3 | 139.7 | | 12.7 | |
| FSM9984NB | 114.3*139.7*12.7 TB | | 114.3 | 139.7 | | 12.7 | |
| FSM9993NB | 114.3*139.7*12.7 TC | | 114.3 | 139.7 | | 12.7 | |
| FSM0010NB | 114.3*139.85*12.7 TC | | 114.3 | 139.85 | | 12.7 | |
| FSN0100NB | 72*140*12 TB | | 72 | 140 | | 12 | |
| FSM0116NB | 80*140*12 TC | | 80 | 140 | | 12 | |
| FSM138NB | 80*140*13 SC | | 80 | 140 | | 13 | |
| FSM0041NB | 80*140*13 TC | | 80 | 140 | | 13 | |
| FSM0117NB | 85*140*10 TC | | 85 | 140 | | 10 | |
| FSK0070NB | 85*140*12 SC | | 85 | 140 | | 12 | |
| FSM0064NB | 85*140*12 TC | | 85 | 140 | | 12 | |
| FSM0064FB | 85*140*12 TC(VITON) | | 85 | 140 | | 12 | |
| FSM0104NB | 85*140*14 TC | | 85 | 140 | | 14 | |
| FSN0105NB | 90*140*10 TC | | 90 | 140 | | 10 | |
| FSN0097NB | 90*140*12 TB | | 90 | 140 | | 12 | |
| FSM0106NB | 90*140*12 TC | | 90 | 140 | | 12 | |
| FSN0049NB | 90*140*13 SC | | 90 | 140 | | 13 | |
| FSM0152NB | 90*140*13 TB | | 90 | 140 | | 13 | |
| FSM0027NB | 90*140*13 TC | | 90 | 140 | | 13 | |

| WLK CODE | OIL SEALS | DESCRIPTION | ID | OD1 | OD2 | H1 | H2 |
|-----------|--------------------------|-------------|-----|-----|-----|------|------|
| FSN0108NB | 95*140*13 TB | | 95 | 140 | | 13 | |
| FSM0065NB | 100*140*12 TC | | 100 | 140 | | 12 | |
| FSM0016NB | 100*140*13 TC | | 100 | 140 | | 13 | |
| FSM0016FB | 100*140*13 TC(VITON) | | 100 | 140 | | 13 | |
| FSM0155NB | 100*140*14 TC | | 100 | 140 | | 14 | |
| FSM0126NB | 100*140*15 TC | | 100 | 140 | | 15 | |
| FSM0147FB | 100*140*15.5/20 AXLE(FKM | VITON | 100 | 140 | | 15.5 | 20 |
| FSN0158NB | 103*140*12 TB | | 103 | 140 | | 12 | |
| FSM0097NB | 105*140*12 SC | | 105 | 140 | | 12 | |
| FSM0097FB | 105*140*12 SC(VITON) | | 105 | 140 | | 12 | |
| FSM0081NB | 105*140*12 TC | | 105 | 140 | | 12 | |
| FSM0081FB | 105*140*12 TC(VITON)FKM | | 105 | 140 | | 12 | |
| FSN0043NB | 105*140*13 TC | | 105 | 140 | | 13 | |
| FSN0043FB | 105*140*13 TC(VITON) | | 105 | 140 | | 13 | |
| FSN0043QB | 105*140*13 TC(VMQ) | | 105 | 140 | | 13 | |
| FSM0123NB | 105*140*14 SA | | 105 | 140 | | 14 | |
| FSM0105NB | 105*140*14 TC | | 105 | 140 | | 14 | |
| FSM0102NB | 105*140*15 TC | | 105 | 140 | | 15 | |
| FSM0153NB | 110*140*10 SC | | 110 | 140 | | 10 | |
| FSM0135NB | 110*140*12 SB | | 110 | 140 | | 12 | |
| FSM0145FB | 110*140*12 SC(VIOTN) | | 110 | 140 | | 12 | |
| FSM0083NB | 110*140*12 TA | | 110 | 140 | | 12 | |
| FSM0084NB | 110*140*12 TB | | 110 | 140 | | 12 | |
| FSM0045NB | 110*140*12 TC | | 110 | 140 | | 12 | |
| FSM0045FB | 110*140*12 TC(VITON) | | 110 | 140 | | 12 | |
| FSM0148NB | 110*140*12/21.5 HTACYW | | 110 | 140 | | 12 | 21.5 |
| FSM0012NB | 110*140*13 SB | | 110 | 140 | | 13 | |
| FSM0050NB | 110*140*13 SC | | 110 | 140 | | 13 | |
| FSM0136NB | 110*140*13 TB | 8176 | 110 | 140 | | 13 | |
| FSM0023NB | 110*140*13 TC | | 110 | 140 | | 13 | |
| FSM0023FB | 110*140*13 TC(VITON) | | 110 | 140 | | 13 | |
| FSM0023QB | 110*140*13 TC(VMQ) | | 110 | 140 | | 13 | |
| FSM0120NB | 110*140*14 TB | | 110 | 140 | | 14 | |
| FSM0067NB | 110*140*14 TC | | 110 | 140 | | 14 | |
| FSM0067FB | 110*140*14 TC(VITON) | | 110 | 140 | | 14 | |
| FSM0087NB | 110*140*14 TCN | | 110 | 140 | | 14 | |
| FSM0108NB | 110*140*15 TC | | 110 | 140 | | 15 | |
| FSM0068NB | 112*140*13 TC | | 112 | 140 | | 13 | |
| FSM0143NB | 113*140*13 SA | | 113 | 140 | | 13 | |
| FSM0053NB | 114*140*13 TC | | 114 | 140 | | 13 | |
| FSM0107FB | 115*140*10 SC(VITON)FKM | | 115 | 140 | | 10 | |
| FSM0013NB | 115*140*12 SC | | 115 | 140 | | 12 | |
| FSM0013FB | 115*140*12 SC(FKM)VITON | | 115 | 140 | | 12 | |
| FSM0139FB | 115*140*12 TB(VITON) | | 115 | 140 | | 12 | |
| FSM0082NB | 115*140*12 TC | | 115 | 140 | | 12 | |
| FSM0082FB | 115*140*12 TC(VITON)FKM | | 115 | 140 | | 12 | |
| FSM0024NB | 115*140*13 TC | | 115 | 140 | | 13 | |
| FSM0024FB | 115*140*13 TC(VITON) | | 115 | 140 | | 13 | |
| FSM0035NB | 115*140*14 SA | | 115 | 140 | | 14 | |
| FSM0077NB | 115*140*14 TC | | 115 | 140 | | 14 | |
| FSM0077FB | 115*140*14 TC(VITON) | | 115 | 140 | | 14 | |
| FSM0101NB | 115*140*15 TC | | 115 | 140 | | 15 | |
| FSM0149NB | 115*140*16 TB | | 115 | 140 | | 16 | |
| FSM0127NB | 115*140*16 TC | | 115 | 140 | | 16 | |
| FSM0054NB | 118*140*13 TC | | 118 | 140 | | 13 | |
| FSM0151NB | 120*140*10 SC | | 120 | 140 | | 10 | |
| FSM0133NB | 120*140*10 TA | | 120 | 140 | | 10 | |

| WLK CODE | OIL SEALS | DESCRIPTION | ID | OD1 | OD2 | H1 | H2 |
|-----------|----------------------------|------------------------|--------|---------|-----|-------|----|
| FSM0074NB | 120*140*10 TC | | 120 | 140 | | 10 | |
| FSM0051NB | 120*140*10.5 TB3 | 1-09625-041-1 | 120 | 140 | | 10.5 | |
| FSM0049NB | 120*140*11 TC | | 120 | 140 | | 11 | |
| FSM0140FB | 120*140*12 SC(VITON) | | 120 | 140 | | 12 | |
| FSM0062NB | 120*140*12 TB | | 120 | 140 | | 12 | |
| FSN0038NB | 120*140*12 TC | | 120 | 140 | | 12 | |
| FSM0141FB | 120*140*13 SC(VITON) | | 120 | 140 | | 13 | |
| FSM0014NB | 120*140*13 TB | | 120 | 140 | | 13 | |
| FSM0026NB | 120*140*13 TC | | 120 | 140 | | 13 | |
| FSM0026QB | 120*140*13 TC(VMQ) | | 120 | 140 | | 13 | |
| FSM0072NB | 120*140/146*13 HTC5L | 12279-95000/04 | 120 | 140 | 146 | 13 | |
| FSM0052NB | 120*140*14 TC | | 120 | 140 | | 14 | |
| FSM0052FB | 120*140*14 TC(VITON) | | 120 | 140 | | 14 | |
| FSM0058QB | 120*140*15 HTGL(VMQ) | | 120 | 140 | | 15 | |
| FSM0103NB | 120*140*15 TC | | 120 | 140 | | 15 | |
| FSM0089N0 | 125*140*7 VB | | 125 | 140 | | 7 | |
| FSM0134NB | 125*140*10 SC | | 125 | 140 | | 10 | |
| FSM0128NB | 125*140*10 TC | | 125 | 140 | | 10 | |
| FSM0114NB | 125*140*13 TC | | 125 | 140 | | 13 | |
| FSN0003NB | 110*140.15*13 HTA(W) Blue | 110*139.95*13 HTA(W) | 110 | 140.15 | | 13 | |
| FSN0033NB | 121.44*140.77*11.91 HSC | NBR (Red)(S14007) | 121.44 | 140.77 | | 11.91 | |
| FSN0035NB | 121.06*140.89*11.68 HTC | 4.766*5.547*0.46 HTC | 121.06 | 140.89 | | 11.68 | |
| FSN0005NB | 119*141.2*12 HSC (Red) | | 119 | 141.2 | | 12 | |
| FSN0090NB | 70*142*12/36 TA9Y | MC-827475 噴橘漆 | 70 | 142 | | 12 | 36 |
| FSN0147NB | 74*142*14 TCY | | 74 | 142 | | 14 | |
| FSN0127NB | 93*142*15 KCY | | 93 | 142 | | 15 | |
| FSN0111NB | 100*142*12 TB | | 100 | 142 | | 12 | |
| FSN0085NB | 110*142*12 HTCL | NISSAN車用 | 110 | 142 | | 12 | |
| FSN0124NB | 110*142*12 SB | | 110 | 142 | | 12 | |
| FSN0155NB | 114*142/170*14/26 SBY | | 114 | 142 | 170 | 14 | 26 |
| FSN0058NB | 117.47*142.87*12.7 SC | | 117.47 | 142.87 | | 12.7 | |
| FSN0099NB | 117.47*142.87*12.7 TA | | 117.47 | 142.87 | | 12.7 | |
| FSN9994NB | 101.6*142.88*9.53 TA | | 101.6 | 142.88 | | 9.53 | |
| FSN9994FB | 101.6*142.88*9.53 TA(FKM) | VITON | 101.6 | 142.88 | | 9.53 | |
| FSN9988NB | 101.6*142.88*9.53 TB | | 101.6 | 142.88 | | 9.53 | |
| FSN9993NB | 114.3*142.88*12.7 TA | | 114.3 | 142.88 | | 12.7 | |
| FSN0152FB | 117.47*142.88*12.7 TC(FKM) | VITON | 117.47 | 142.88 | | 12.7 | |
| FSN0148NB | 74*143*17.5 TCY | | 74 | 143 | | 17.5 | |
| FSN0079NB | 80*143*10/37 HTBR9Y | NJ935(1-09625-030-0) | 80 | 143 | | 10 | 37 |
| FSN0001NB | 90*143*13 SC | | 90 | 143 | | 13 | |
| FSN0151NB | 125*143*13 TC | | 125 | 143 | | 13 | |
| FSM9980NB | 98.43*144.48*12.7 TC | | 98.43 | 144.48 | | 12.7 | |
| FSM0043NB | 98.43*144.48*19.05 TA | | 98.43 | 144.48 | | 19.05 | |
| FSM0034NB | 98.552*144.526*12.7 TB | 3.880*5.690*0.500 TB | 98.552 | 144.526 | | 12.7 | |
| FSM9998NB | 98.43*144.53*22.23 Y | 3.875*5.690*0.875 Y | 98.43 | 144.53 | | 22.23 | |
| FSN9999NB | 98.55*144.53*12.70 SA | 3.880*5.690*0.500 SA紅漆 | 98.55 | 144.53 | | 12.7 | |
| FSN0007NB | 98.5*144.65*19 SA | 0007-B | 98.5 | 144.65 | | 19 | |
| FSN0076NB | 86*145*10 TC | | 86 | 145 | | 10 | |
| FSN0109NB | 90*145*12 SB | | 90 | 145 | | 12 | |
| FSN0081NB | 95*145*12 TC | | 95 | 145 | | 12 | |
| FSN0126NB | 95*145*13 TC | | 95 | 145 | | 13 | |
| FSN0070NB | 100*145*13 TC | | 100 | 145 | | 13 | |
| FSN0064NB | 100*145*15/26 TAY | 9-09924-416-0 | 100 | 145 | | 15 | 26 |
| FSN0145NB | 105*145*13 TC | | 105 | 145 | | 13 | |
| FSN0130NB | 105*145*15 SB | | 105 | 145 | | 15 | |
| FSN0087NB | 105*145*15 TC | | 105 | 145 | | 15 | |
| FSN0077NB | 110*145*13 TA | | 110 | 145 | | 13 | |

| WLK CODE | OIL SEALS | DESCRIPTION | ID | OD1 | OD2 | H1 | H2 |
|-----------|------------------------------------|------------------------|--------|--------|-----|--------|----|
| FSN0132NB | 110*145*13 TB | | 110 | 145 | | 13 | |
| FSN0114NB | 110*145*13 TC | | 110 | 145 | | 13 | |
| FSN0002NB | 110*145*14 TC | | 110 | 145 | | 14 | |
| FSN0002FB | 110*145*14 TC(VITON) | | 110 | 145 | | 14 | |
| FSN0115NB | 110*145*15 SC | | 110 | 145 | | 15 | |
| FSN0093NB | 110*145*15 TB | | 110 | 145 | | 15 | |
| FSN0063NB | 110*145*15 TC | | 110 | 145 | | 15 | |
| FSN0112NB | 114*145*13 TC | | 114 | 145 | | 13 | |
| FSN0113NB | 115*145*11 SB | | 115 | 145 | | 11 | |
| FSN0138FB | 115*145*13 SC(VITON) | | 115 | 145 | | 13 | |
| FSN0069NB | 115*145*13 TC | | 115 | 145 | | 13 | |
| FSN0073NB | 115*145*14 TB | | 115 | 145 | | 14 | |
| FSN0057N | 115*145*14 TC | | 115 | 145 | | 14 | |
| FSN0057FB | 115*145*14 TC(VITON) | | 115 | 145 | | 14 | |
| FSN0117NB | 115*145*15 SC | | 115 | 145 | | 15 | |
| FSQ0019NB | 117*145/174*15.5/28 TAY | 1-09625-350-0 | 117 | 145 | 174 | 15.5 | 28 |
| FSN0075NB | 120*145*10 HTCL | BH-5011 | 120 | 145 | | 10 | |
| FSN0071NB | 120*145*10 TC | | 120 | 145 | | 10 | |
| FSN0044NB | 120*145*12 TC | | 120 | 145 | | 12 | |
| FSN0044FB | 120*145*12 TC(FKM)VITON | | 120 | 145 | | 12 | |
| FSN0122NB | 120*145*13 TC | | 120 | 145 | | 13 | |
| FSN0122FB | 120*145*13 TC(VITON) | | 120 | 145 | | 13 | |
| FSN0139NB | 120*145*13 TZ | | 120 | 145 | | 13 | |
| FSN0067NB | 120*145*14 TC | | 120 | 145 | | 14 | |
| FSN0009NB | 120*145*15 HTA(W) | 01884-BG | 120 | 145 | | 15 | |
| FSN0084NB | 120*145*15 TA | | 120 | 145 | | 15 | |
| FSN0050NB | 120*145*15 TC | | 120 | 145 | | 15 | |
| FSN0123NB | 125*145*10 HTCL | | 125 | 145 | | 10 | |
| FSN0080NB | 125*145*12 TC | | 125 | 145 | | 12 | |
| FSN0027NB | 125*145*13 TC | | 125 | 145 | | 13 | |
| FSN0131QB | 116*146*12/18 HTC9L(VMQ) | N油封 | 116 | 146 | | 12 | 18 |
| FSN0061NB | 125*146*12 TC | | 125 | 146 | | 12 | |
| FSN0062NB | 125*146*14 TC | | 125 | 146 | | 14 | |
| FSN0060NB | 126*146*10 TC | | 126 | 146 | | 10 | |
| FSN0144NB | 126*146*10 TZ | | 126 | 146 | | 10 | |
| FSN0072NB | 127*146*10 TB | | 127 | 146 | | 10 | |
| FSN0101NB | 127*146*10 TB3 | 43090-Z5001 | 127 | 146 | | 10 | |
| FSN0083NB | 127*146*10 TC | | 127 | 146 | | 10 | |
| FSN0052NB | 127*146*12 TC | | 127 | 146 | | 12 | |
| FSN0078NB | 130*146*14 TB | | 130 | 146 | | 14 | |
| FSN0042NB | 101.6*146.05*12.7 SC | | 101.6 | 146.05 | | 12.7 | |
| FSN9991NB | 107.95*146.05*12.7 TC | | 107.95 | 146.05 | | 12.7 | |
| FSN9989NB | 111.13*146.05*14.3 TA | | 111.13 | 146.05 | | 14.3 | |
| FSN0031NB | 114.3*146.05*12.7 TA | 4.50*5.75*0.5 TA噴綠漆 | 114.3 | 146.05 | | 12.7 | |
| FSN9985NB | 117.48*146.05*12.7 TB | | 117.48 | 146.05 | | 12.7 | |
| FSN9998QB | 120.6*146.05*12.7 TC(VMQ) | 4.75*5.75*0.50 TC(VMQ) | 120.6 | 146.05 | | 12.7 | |
| FSN9990NB | 120.65*146.05*9.53 SB | | 120.65 | 146.05 | | 9.53 | |
| FSN9996NB | 120.65*146.05*12.7 TA | | 120.65 | 146.05 | | 12.7 | |
| FSN9995NB | 120.65*146.05*12.7 TB | | 120.65 | 146.05 | | 12.7 | |
| FSN9995FB | 120.65*146.05*12.7 TB(FKM) | VITON | 120.65 | 146.05 | | 12.7 | |
| FSN9998NB | 120.65*146.05*12.7 TC | 4.75*5.75*0.50 TC | 120.65 | 146.05 | | 12.7 | |
| FSN0121NB | 120.65*146.05*14.3 TA | | 120.65 | 146.05 | | 14.3 | |
| FSN9987NB | 125.43*146.05*12.7 TA | | 125.43 | 146.05 | | 12.7 | |
| FSN9992NB | 127*146.05*11.13 TC | | 127 | 146.05 | | 11.13 | |
| FSN9986NB | 76.2*146.07*21.336 TB5Y | 3.000*5.751*0.840 TB5Y | 76.2 | 146.07 | | 21.336 | |
| FSN0006QB | 119*146.2*13 SA(VMQ) Blue Painting | | 119 | 146.2 | | 13 | |
| FSN0010QB | 120.5*146.2*20 DA Red | | 120.5 | 146.2 | | 20 | |

| WLK CODE | OIL SEALS | DESCRIPTION | ID | OD1 | OD2 | H1 | H2 |
|-----------|-------------------------|---------------|-------|-----|-----|------|----|
| FSN0055NB | 127*147*11 TB3 | 9828-01203 | 127 | 147 | | 11 | |
| FSN0141NB | 127*147*11.5 TZ | | 127 | 147 | | 11.5 | |
| FSN0051NB | 128*148*14 HTCL | 1-09625-441-0 | 128 | 148 | | 14 | |
| FSN0088NB | 85*150*12 TC | | 85 | 150 | | 12 | |
| FSN0128NB | 85*150*13 SB | | 85 | 150 | | 13 | |
| FSN0125NB | 85*150*13 SC | | 85 | 150 | | 13 | |
| FSN0120NB | 100*150*12 TC | | 100 | 150 | | 12 | |
| FSN0120FB | 100*150*12 TC(VITON) | | 100 | 150 | | 12 | |
| FSN0154NB | 100*150*13 TB | | 100 | 150 | | 13 | |
| FSN0022NB | 100*150*13 TC | | 100 | 150 | | 13 | |
| FSN0022FB | 100*150*13 TC(VITON) | | 100 | 150 | | 13 | |
| FSN0095NB | 100*150*15 TC | | 100 | 150 | | 15 | |
| FSN0116NB | 105*150*13 TC | | 105 | 150 | | 13 | |
| FSN0089NB | 105*150*15 TC | | 105 | 150 | | 15 | |
| FSN0098NB | 110*150*12 TB | | 110 | 150 | | 12 | |
| FSN0020NB | 110*150*13 TC | | 110 | 150 | | 13 | |
| FSN0135NB | 110*150*15 SB | | 110 | 150 | | 15 | |
| FSN0082NB | 110*150*15 TB | | 110 | 150 | | 15 | |
| FSN0059NB | 110*150*15 TC | | 110 | 150 | | 15 | |
| FSN0023NB | 115*150*12 TC | | 115 | 150 | | 12 | |
| FSN0023FB | 115*150*12 TC(VITON) | | 115 | 150 | | 12 | |
| FSO0001NB | 115*150*13 SA | | 115 | 150 | | 13 | |
| FSN0037NB | 115*150*13 TC | | 115 | 150 | | 13 | |
| FSN0136NB | 115*150*13/17 KA04YL | | 115 | 150 | | 13 | 17 |
| FSN0118NB | 115*150*14 TC | | 115 | 150 | | 14 | |
| FSN0106NB | 115*150*15 TC | | 115 | 150 | | 15 | |
| FSN0106FB | 115*150*15 TC(VITON) | | 115 | 150 | | 15 | |
| FSN0133NB | 118*150*12 TC | | 118 | 150 | | 12 | |
| FSN0149NB | 120*150*10 TC | | 120 | 150 | | 10 | |
| FSN0053NB | 120*150*11 TC | | 120 | 150 | | 11 | |
| FSO0028NB | 120*150*12 SC | | 120 | 150 | | 12 | |
| FSO0028FB | 120*150*12 SC(VITON)FKM | | 120 | 150 | | 12 | |
| FSN0024NB | 120*150*12 TC | | 120 | 150 | | 12 | |
| FSN0024FB | 120*150*12 TC (VITON) | | 120 | 150 | | 12 | |
| FSN0137FB | 120*150*13 SC(VITON) | | 120 | 150 | | 13 | |
| FSN0045NB | 120*150*13 TB | | 120 | 150 | | 13 | |
| FSN0025NB | 120*150*13 TC | | 120 | 150 | | 13 | |
| FSN0025FB | 120*150*13 TC(VITON) | | 120 | 150 | | 13 | |
| FSN0025QB | 120*150*13 TC(VMQ) | | 120 | 150 | | 13 | |
| FSN0021NB | 120*150*14 TC | 90311-99020 | 120 | 150 | | 14 | |
| FSN0021FB | 120*150*14 TC(VITON) | | 120 | 150 | | 14 | |
| FSN0103NB | 120*150*14 TCN | | 120 | 150 | | 14 | |
| FSN0086NB | 120*150*14 TZ | | 120 | 150 | | 14 | |
| FSN0026NB | 120*150*15 TC | | 120 | 150 | | 15 | |
| FSN0026FB | 120*150*15 TC(VITON) | | 120 | 150 | | 15 | |
| FSN0156NB | 121.8*150*13 AXLE | | 121.8 | 150 | | 13 | |
| FSN0092NB | 122*150*12 TC | | 122 | 150 | | 12 | |
| FSN0091NB | 122*150*12/18 HTC9L | 9828-01194 | 122 | 150 | | 12 | 18 |
| FSN0143NB | 125*150*12 SA | | 125 | 150 | | 12 | |
| FSN0134NB | 125*150*12 SB | | 125 | 150 | | 12 | |
| FSN0036NB | 125*150*12 SC | | 125 | 150 | | 12 | |
| FSN0142NB | 125*150*12 TB | | 125 | 150 | | 12 | |
| FSN0047NB | 125*150*12 TC | | 125 | 150 | | 12 | |
| FSN0047FB | 125*150*12 TC(VITON) | | 125 | 150 | | 12 | |
| FSN0129FB | 125*150*13 SC(VITON) | TC型修掉副唇 | 125 | 150 | | 13 | |
| FSN0119NB | 125*150*13 TB | | 125 | 150 | | 13 | |
| FSN0041NB | 125*150*13 TC | | 125 | 150 | | 13 | |

| WLK CODE | OIL SEALS | DESCRIPTION | ID | OD1 | OD2 | H1 | H2 |
|-----------|-----------------------------------|------------------------|--------|--------|-----|-------|-----|
| FSN0041FB | 125*150*13 TC(VITON)FKM | | 125 | 150 | | 13 | |
| FSN0048NB | 125*150*14 TB | MH-034086 | 125 | 150 | | 14 | |
| FSN0028NB | 125*150*14 TC | | 125 | 150 | | 14 | |
| FSN0028FB | 125*150*14 TC(VITON) | | 125 | 150 | | 14 | |
| FSN0019NB | 125*150*15 TA | 01735-BGE | 125 | 150 | | 15 | |
| FSN0034NB | 125*150*15 TC | | 125 | 150 | | 15 | |
| FSN0034FB | 125*150*15 TC(VITON) | | 125 | 150 | | 15 | |
| FSN0034QB | 125*150*15 TC(VMQ) | | 125 | 150 | | 15 | |
| FSN0110NB | 127*150*12 HSCL | | 127 | 150 | | 12 | |
| FSN0110QB | 127*150*12 HSCL(VMQ) | | 127 | 150 | | 12 | |
| FSN0157NB | 128*150*13 SC | | 128 | 150 | | 13 | |
| FSN0065NB | 128*150*13 TC | | 128 | 150 | | 13 | |
| FSN0054NB | 130*150*10 TB3 | 43090-Z5000 | 130 | 150 | | 10 | |
| FSN0029NB | 130*150*10 TC | | 130 | 150 | | 10 | |
| FSN0140FB | 130*150*11 TC(VITON) | | 130 | 150 | | 11 | |
| FSN0096NB | 130*150*12 TC | | 130 | 150 | | 12 | |
| FSN0096FB | 130*150*12 TC(VITON) | | 130 | 150 | | 12 | |
| FSN0040NB | 130*150*13 TC | | 130 | 150 | | 13 | |
| FSN0068NB | 130*150*14 SB | | 130 | 150 | | 14 | |
| FSN0039NB | 130*150*14 TB | MH-034092 | 130 | 150 | | 14 | |
| FSN0102NB | 130*150*14 TB3 | MH-034087 | 130 | 150 | | 14 | |
| FSN0030NB | 130*150*14 TC | | 130 | 150 | | 14 | |
| FSN0030FB | 130*150*14 TC(VITON) | | 130 | 150 | | 14 | |
| FSN0107NB | 130*150*15 TC | | 130 | 150 | | 15 | |
| FSN0107FB | 130*150*15 TC(VITON) | | 130 | 150 | | 15 | |
| FSN0074NB | 132*150/156*14 HTC5L | BH1306E | 132 | 150 | 156 | 14 | |
| FSO9992NB | 111.13*150.01*25.4 TA | | 111.13 | 150.01 | | 25.4 | |
| FSN0032NB | 110*151*3/6.5 Y | BZ2524-E軟墊 | 110 | 151 | | 3 | 6.5 |
| FSO0111N0 | 100*152*12 KC | | 100 | 152 | | 12 | |
| FSO0116NB | 132*152*13 TM | | 132 | 152 | | 13 | |
| FSO0041NB | 134*152*11 TBP | MH-034089 | 134 | 152 | | 11 | |
| FSO0042NB | 134*152*11 TC(BROWN) | | 134 | 152 | | 11 | |
| FSO0095NB | 134*152*13 TB | | 134 | 152 | | 13 | |
| FSO0009NB | 138*152*12 TB | 9828-01125, 9828-01165 | 138 | 152 | | 12 | |
| FSO0022NB | 138*152*12 TM3 | 9828-01165 | 138 | 152 | | 12 | |
| FSO0002NB | 117.48*152.37*12.7 TA2 | 4.625*5.999*0.500 TA2 | 117.48 | 152.37 | | 12.7 | |
| FSO9970NB | 101.6*152.4*12.7 TC | | 101.6 | 152.4 | | 12.7 | |
| FSO9978NB | 101.6*152.4*15.88 TA | | 101.6 | 152.4 | | 15.88 | |
| FSO9967NB | 106.38*152.4*15.88 TA | | 106.38 | 152.4 | | 15.88 | |
| FSO0034NB | 107.9*152.4*14.22 TC | | 107.9 | 152.4 | | 14.22 | |
| FSO9974NB | 107.95*152.4*12.7 SC | | 107.95 | 152.4 | | 12.7 | |
| FSO9982NB | 111.13*152.4*12.7 TC | 4.375*6.000*0.500 | 111.13 | 152.4 | | 12.7 | |
| FSO0023NB | 114.3*152.4*12.7 TA Blue Painting | 4.50*6.00*0.5 TA藍綠漆 | 114.3 | 152.4 | | 12.7 | |
| FSO9979NB | 114.3*152.4*12.7 TC | | 114.3 | 152.4 | | 12.7 | |
| FSO9990NB | 117.48*152.4*27 Y(SCOTT) | 370025(CR46305) NBR80 | 117.48 | 152.4 | | 27 | |
| FSO9976NB | 120.65*152.4*12.7 SC | | 120.65 | 152.4 | | 12.7 | |
| FSO9986NB | 120.65*152.4*12.7 TA | | 120.65 | 152.4 | | 12.7 | |
| FSO9989NB | 120.65*152.4*12.7 TC | | 120.65 | 152.4 | | 12.7 | |
| FSO9997NB | 120.65*152.4*14.22 SC | 4.75*6.00*0.56 SC | 120.65 | 152.4 | | 14.22 | |
| FSM0032NB | 120.65*152.4*14.23 TB | 4.75*6.00*0.56 TB | 120.65 | 152.4 | | 14.23 | |
| FSO9963NB | 120.65*152.4*15.88 TA | | 120.65 | 152.4 | | 15.88 | |
| FSO0073NB | 125*152.4*12 TC | | 125 | 152.4 | | 12 | |
| FSO0096NB | 125*152.4*15 SA | | 125 | 152.4 | | 15 | |
| FSO0110NB | 125*152.4*15 TA | | 125 | 152.4 | | 15 | |
| FSO9973NB | 125.43*152.4*12.7 TC | | 125.43 | 152.4 | | 12.7 | |
| FSO9996NB | 127*152.4*12.7 TC | 5.000*6.000*0.500 TC | 127 | 152.4 | | 12.7 | |
| FSO9977NB | 127*152.48*12.7 TA | | 127 | 152.48 | | 12.7 | |

| WLK CODE | OIL SEALS | DESCRIPTION | ID | OD1 | OD2 | H1 | H2 |
|-----------|-------------------------------|-------------------------|--------|--------|-----|-------|------|
| FSO0074NB | 108*152.6*13 TB | | 108 | 152.6 | | 13 | |
| FSO0060NB | 120*153*15 HTCR | 1-09625-025-0 | 120 | 153 | | 15 | |
| FSO9993NB | 107.95*153.62*17.27 Y | 4.250*6.048*0.680 Y | 107.95 | 153.62 | | 17.27 | |
| FSO0067NB | 93*154*8/11.4 KB2Y(有7孔) | BF2991F | 93 | 154 | | 8 | 11.4 |
| FSO0072NB | 100*154*34 | 90310-99011 | 100 | 154 | | 34 | |
| FSO0063NB | 110*154*12/34 Y | | 110 | 154 | | 12 | 34 |
| FSO0113NB | 130*154*11 TC | | 130 | 154 | | 11 | |
| FSO0105NB | 74*154.5/156/162*14/22 TG359Y | BE5384E | 74 | 154.5 | 156 | 14 | 22 |
| FSO0118NB | 76*155/164*11.5/14 TC359Y | | 76 | 155 | 164 | 11.5 | 14 |
| FSO0099NB | 120*155*12 TC | | 120 | 155 | | 12 | |
| FSO0066NB | 120*155*15 TC | | 120 | 155 | | 15 | |
| FSO0003NB | 120*155*16 TC | | 120 | 155 | | 16 | |
| FSO0104NB | 125*155*12 SC | | 125 | 155 | | 12 | |
| FSO0106FB | 125*155*12 TC(VITON) | | 125 | 155 | | 12 | |
| FSO0076NB | 125*155*14 HTCL | | 125 | 155 | | 14 | |
| FSO0050NB | 125*155*14 TA | | 125 | 155 | | 14 | |
| FSO0065NB | 125*155*14 TB | | 125 | 155 | | 14 | |
| FSO0013NB | 125*155*14 TC | | 125 | 155 | | 14 | |
| FSO0013FB | 125*155*14 TC(VITON) | | 125 | 155 | | 14 | |
| FSO0035QB | 125*155*14/23 HTC9(VMQ) | 9828-01201 N油封 | 125 | 155 | | 14 | 23 |
| FSO0089NB | 125*155*15 TC | | 125 | 155 | | 15 | |
| FSO0056NB | 130*155*10 SC | | 130 | 155 | | 10 | |
| FSO0062NB | 130*155*12 TA | | 130 | 155 | | 12 | |
| FSO0094NB | 130*155*12 TC | | 130 | 155 | | 12 | |
| FSO0123PB | 130*155*12.5/16 AXLE | | 130 | 155 | | 12.5 | 16 |
| FSO0090NB | 130*155*13 TC | | 130 | 155 | | 13 | |
| FSO0083NB | 130*155*14 TC | | 130 | 155 | | 14 | |
| FSO0057NB | 135*155*13 TC | | 135 | 155 | | 13 | |
| FSO0025QB | 135*155*15 OVC(VMQ)NOK | 31212-33300 BLUE | 135 | 155 | | 15 | |
| FSO0086NB | 135*155*15 TA | | 135 | 155 | | 15 | |
| FSO0043NB | 138*155*11 HTCL | NISSAN RE8 曲軸後 | 138 | 155 | | 11 | |
| FSO0044NB | 138*155*11 TC(BROWN) | | 138 | 155 | | 11 | |
| FSO0100QB | 135*155.5*15 OVC(VMQ) | | 135 | 155.5 | | 15 | |
| FSO9971NB | 134.54*155.57*9.53 SC | | 134.54 | 155.57 | | 9.53 | |
| FSO9980NB | 114.3*155.58*14.3 TC | 4.500*6.125*0.563 TC | 114.3 | 155.58 | | 14.3 | |
| FSO9964NB | 130.18*155.58*12.7 SC | | 130.18 | 155.58 | | 12.7 | |
| FSO0018NB | 130.18*155.58*12.7 TC | 5.125*6.125*0.500 TC | 130.18 | 155.58 | | 12.7 | |
| FSO9994NB | 133.35*155.58*14.27 TM | | 133.35 | 155.58 | | 14.27 | |
| FSN0146NB | 115*156*15/27 TAY | | 115 | 156 | | 15 | 27 |
| FSO0077NB | 76*157*8/19 Y | 9828-76101/02 | 76 | 157 | | 8 | 19 |
| FSO0027NB | 133*157*14 HTCL NBR | 12279-97003 | 133 | 157 | | 14 | |
| FSO0027QB | 133*157*14 HTCL(VMQ) | 12279-97003 | 133 | 157 | | 14 | |
| FSO0054QB | 133*157/165*18 Y | W/BZ5333E | 133 | 157 | 165 | 18 | |
| FSO0085NB | 138*157*18 Y(HTC5L) | BZ5333E+鐵圈 | 138 | 157 | | 18 | |
| FSO0019NB | 132*158*7/12.5 TCY(HTGL) | 5.172*6.25*0.4844/.5469 | 132 | 158 | | 7 | 12.5 |
| FSO0008NB | 133.85*158.7*12.7 HTC | Perkins 2418F475 | 133.85 | 158.7 | | 12.7 | |
| FSO0008FB | 133.85*158.7*12.7 HTC(FKM) | Perkins 2418F475(VITON) | 133.85 | 158.7 | | 12.7 | |
| FSO9991NB | 111.13*158.75*12.7 TA | | 111.13 | 158.75 | | 12.7 | |
| FSO9984NB | 111.13*158.75*14.3 TC | | 111.13 | 158.75 | | 14.3 | |
| FSO9987NB | 114.3*158.75*12.7 SA | | 114.3 | 158.75 | | 12.7 | |
| FSO9983NB | 114.3*158.75*12.7 TA | | 114.3 | 158.75 | | 12.7 | |
| FSO9995NB | 123.83*158.75*14.3 TB | | 123.83 | 158.75 | | 14.3 | |
| FSO9966NB | 125.43*158.75*12.7 TA | | 125.43 | 158.75 | | 12.7 | |
| FSO9998NB | 127*158.75*12.7 TA | 5.00*6.25*0.50 TA | 127 | 158.75 | | 12.7 | |
| FSO9972NB | 127*158.75*12.7 TC | | 127 | 158.75 | | 12.7 | |
| FSO9985NB | 127*158.75*14.28 SA | | 127 | 158.75 | | 14.28 | |
| FSO0052NB | 127*158.75*14.3 SC | | 127 | 158.75 | | 14.3 | |

| WLK CODE | OIL SEALS | DESCRIPTION | ID | OD1 | OD2 | H1 | H2 |
|-----------|----------------------------|--------------------------|--------|--------|-----|-------|------|
| FSO9965NB | 131.78*158.75*12.7 SC | | 131.78 | 158.75 | | 12.7 | |
| FSO9975NB | 133.35*158.75*11.1 TB | | 133.35 | 158.75 | | 11.1 | |
| FSO9969NB | 133.35*158.75*11.13 TB | | 133.35 | 158.75 | | 11.13 | |
| FSO9981NB | 133.35*158.75*12.7 TA | | 133.35 | 158.75 | | 12.7 | |
| FSO9988NB | 133.35*158.75*12.7 TB | | 133.35 | 158.75 | | 12.7 | |
| FSO9999NB | 133.35*158.75*12.7 TC | 5.25*6.25*0.50 TC | 133.35 | 158.75 | | 12.7 | |
| FSO9999FB | 133.35*158.75*12.7 TC(FKM) | 5.25*6.25*0.50 TC(VITON) | 133.35 | 158.75 | | 12.7 | |
| FSO9999QB | 133.35*158.75*12.7 TC(VMQ) | 5.25*6.25*0.50 TC(VMQ) | 133.35 | 158.75 | | 12.7 | |
| FSO0006NB | 132*159*12.5 HSC | | 132 | 159 | | 12.5 | |
| FSO0124NB | 133*159*13 HTCR | | 133 | 159 | | 13 | |
| FSO0121NB | 136*159*13 HTGKJR | | 136 | 159 | | 13 | |
| FSO0093NB | 90*160*12 SC | | 90 | 160 | | 12 | |
| FSO0115NB | 90*160*12 TC | | 90 | 160 | | 12 | |
| FSO0084NB | 95*160*15 SC | | 95 | 160 | | 15 | |
| FSO0058NB | 95*160*15 TC | | 95 | 160 | | 15 | |
| FSO0087NB | 100*160*13 TC | | 100 | 160 | | 13 | |
| FSO0102NB | 105*160*10 TB | | 105 | 160 | | 10 | |
| FSO0070NB | 105*160*12 TB | | 105 | 160 | | 12 | |
| FSO0053NB | 110*160*12 TC | | 110 | 160 | | 12 | |
| FSO0037NB | 110*160*13 TC | | 110 | 160 | | 13 | |
| FSO0119NB | 110*160*15 SC | | 110 | 160 | | 15 | |
| FSO0055NB | 110*160*15 TC | | 110 | 160 | | 15 | |
| FSO0029NB | 110*160*16 TA | | 110 | 160 | | 16 | |
| FSO0088NB | 113*160*12 TCI | | 113 | 160 | | 12 | |
| FSO0075NB | 115*160*13 TB | | 115 | 160 | | 13 | |
| FSO0039NB | 115*160*15 TC | | 115 | 160 | | 15 | |
| FSO0007NB | 120*160*12 TC | | 120 | 160 | | 12 | |
| FSO0007FB | 120*160*12 TC(VITON) | | 120 | 160 | | 12 | |
| FSO0107FB | 120*160*13 SB(VITON) | | 120 | 160 | | 13 | |
| FSO0012NB | 120*160*13 TC | | 120 | 160 | | 13 | |
| FSO0026NB | 120*160*14 TC | | 120 | 160 | | 14 | |
| FSO0032NB | 120*160*15 TC | | 120 | 160 | | 15 | |
| FSO0032FB | 120*160*15 TC(VITON) | | 120 | 160 | | 15 | |
| FSO0112NB | 120*160*15/13 TC4W | | 120 | 160 | | 15 | 13 |
| FSO0081NB | 120*160*16 TC | | 120 | 160 | | 16 | |
| FSO0046NB | 125*160*10 TC | | 125 | 160 | | 10 | |
| FSO0108FB | 125*160*12 SC(VITON) | | 125 | 160 | | 12 | |
| FSO0049NB | 125*160*12 TC | | 125 | 160 | | 12 | |
| FSO0049FB | 125*160*12 TC(VITON) | | 125 | 160 | | 12 | |
| FSO0014FB | 125*160*13 TC(VITON) | | 125 | 160 | | 13 | |
| FSO0021NB | 125*160*15 TC | | 125 | 160 | | 15 | |
| FSO0021FB | 125*160*15 TC(VITON) | | 125 | 160 | | 15 | |
| FSO0122NB | 127*160*15.5/17.5 AXLE | | 127 | 160 | | 15.5 | 17.5 |
| FSO0114FB | 130*160*12 SC(VITON) | | 130 | 160 | | 12 | |
| FSO0010NB | 130*160*12 TC | | 130 | 160 | | 12 | |
| FSO0010FB | 130*160*12 TC(VITON) | | 130 | 160 | | 12 | |
| FSO0120NB | 130*160*13 TA | | 130 | 160 | | 13 | |
| FSO0024NB | 130*160*13 TC | | 130 | 160 | | 13 | |
| FSO0024FB | 130*160*13 TC(VITON) | | 130 | 160 | | 13 | |
| FSO0109FB | 130*160*13 TZ(VITON) | | 130 | 160 | | 13 | |
| FSO0011NB | 130*160*14 TC | 31112-05701 | 130 | 160 | | 14 | |
| FSO0011FB | 130*160*14 TC(VITON) | | 130 | 160 | | 14 | |
| FSO0078NB | 130*160*14 TCN | | 130 | 160 | | 14 | |
| FSO0059NB | 130*160*14 TZ | HINO 用 | 130 | 160 | | 14 | |
| FSO0069QB | 130*160*15 HTGL(VMQ) | | 130 | 160 | | 15 | |
| FSO0061NB | 130*160*15 SC | | 130 | 160 | | 15 | |
| FSO0061FB | 130*160*15 SC(VITON)FKM | | 130 | 160 | | 15 | |

| WLK CODE | OIL SEALS | DESCRIPTION | ID | OD1 | OD2 | H1 | H2 |
|-----------|------------------------------------|--------------------------|--------|--------|-----|-------|-------|
| FSO0015NB | 130*160*15 TC | | 130 | 160 | | 15 | |
| FSO0015FB | 130*160*15 TC(VITON) | | 130 | 160 | | 15 | |
| FSO0015QB | 130*160*15 TC(VMQ) | | 130 | 160 | | 15 | |
| FSO0098NB | 132*160*12 TC | | 132 | 160 | | 12 | |
| FSO0068NB | 135*160*12 SC | | 135 | 160 | | 12 | |
| FSO0068FB | 135*160*12 SC(VITON) | | 135 | 160 | | 12 | |
| FSO0031NB | 135*160*12 TC | | 135 | 160 | | 12 | |
| FSO0031FB | 135*160*12 TC(VITON) | | 135 | 160 | | 12 | |
| FSO0079NB | 135*160*13 SC | | 135 | 160 | | 13 | |
| FSO0101NB | 135*160*13 TB | | 135 | 160 | | 13 | |
| FSO0082NB | 135*160*13 TC | | 135 | 160 | | 13 | |
| FSO0047NB | 135*160*14 SC | | 135 | 160 | | 14 | |
| FSO0048NB | 135*160*14 TC | | 135 | 160 | | 14 | |
| FSO0048FB | 135*160*14 TC(VITON) | | 135 | 160 | | 14 | |
| FSO0051NB | 135*160*15 SA | | 135 | 160 | | 15 | |
| FSO0017NB | 135*160*15 TC | | 135 | 160 | | 15 | |
| FSO0036NB | 138*160*15 TC(Brown) | | 138 | 160 | | 15 | |
| FSO0097NB | 140*160*10 SC | | 140 | 160 | | 10 | |
| FSO0064NB | 140*160*12 TB3 | | 140 | 160 | | 12 | |
| FSO0080NB | 140*160*12 TC | | 140 | 160 | | 12 | |
| FSO0080FB | 140*160*12 TC(VITON) | | 140 | 160 | | 12 | |
| FSO0103NB | 140*160*13 TB | | 140 | 160 | | 13 | |
| FSO0004NB | 140*160*13 TC | | 140 | 160 | | 13 | |
| FSO0004FB | 140*160*13 TC(VITON) | | 140 | 160 | | 13 | |
| FSP0020NB | 140*160*14 TC | | 140 | 160 | | 14 | |
| FSP0020FB | 140*160*14 TC(VITON) | | 140 | 160 | | 14 | |
| FSP0069NB | 140*160*14 TZ | | 140 | 160 | | 14 | |
| FSO0040NB | 140*160*14/16.5 TC59 | 9828-00106 | 140 | 160 | | 14 | 16.5 |
| FSP0051NB | 140*160*15 TC | | 140 | 160 | | 15 | |
| FSO0071NB | 144*160*12 TC | | 144 | 160 | | 12 | |
| FSO0033NB | 144*160*13 TC | | 144 | 160 | | 13 | |
| FSO0091NB | 145*160*13 TB | | 145 | 160 | | 13 | |
| FSO0092NB | 150*160*15 VC | | 150 | 160 | | 15 | |
| FSP9999NB | 121.06*160.3*15.47/28.58 Y | 4.766*6.311*0.609/1.125Y | 121.06 | 160.3 | | 15.47 | 28.58 |
| FSP9997NB | 121.06*160.35*28.58 Y | WLK的 121.06*160.3*15.47 | 121.06 | 160.35 | | 28.58 | |
| FSP0038NB | 130*161*14 HTC3L(Brown) | 9828-01158 | 130 | 161 | | 14 | |
| FSP0026NB | 127*161.93*12.7 TB | | 127 | 161.93 | | 12.7 | |
| FSP9994NB | 136.53*161.93*12.7 TC | | 136.53 | 161.93 | | 12.7 | |
| FSP0078NB | 135*162*13 TZ | | 135 | 162 | | 13 | |
| FSP0025NB | 138*162*14 HTCL | 黑色;咖啡色 | 138 | 162 | | 14 | |
| FSO0038NB | 144*162*14 HTCL(Brown) | | 144 | 162 | | 14 | |
| FSO0038QB | 144*162*14 HTCL(VMQ) | | 144 | 162 | | 14 | |
| FSP0034NB | 78*163*16 TCY | NJ936(1-09625-226-0) | 78 | 163 | | 16 | |
| FSP0016NB | 145*164*14 TB3 | 9828-01204 | 145 | 164 | | 14 | |
| FSP0005NB | 146*164*14 TB | | 146 | 164 | | 14 | |
| FSP0094N0 | 120*165*10 TCLS(KC59Y) | K341 | 120 | 165 | | 10 | |
| FSP0110NB | 120*165*15 TB | | 120 | 165 | | 15 | |
| FSP0050NB | 125*165*15 TC | | 125 | 165 | | 15 | |
| FSP0084FB | 130*165*13 SC(VITON) | TC型修掉副唇 | 130 | 165 | | 13 | |
| FSP0035NB | 130*165*13 TC | | 130 | 165 | | 13 | |
| FSP0035FB | 130*165*13 TC(VITON) | | 130 | 165 | | 13 | |
| FSP0097FB | 130*165*13 TCV(VITON80) | VITON80度 | 130 | 165 | | 13 | |
| FSP0044NB | 130*165*15 TC | | 130 | 165 | | 15 | |
| FSP0003QB | 131*165*15.8 SA(VMQ) Blue Painting | | 131 | 165 | | 15.8 | |
| FSP0081NB | 135*165*12 TC | | 135 | 165 | | 12 | |
| FSP0081FB | 135*165*12 TC(VITON) | | 135 | 165 | | 12 | |
| FSP0021NB | 135*165*13 TC | | 135 | 165 | | 13 | |

| WLK CODE | OIL SEALS | DESCRIPTION | ID | OD1 | OD2 | H1 | H2 |
|-----------|-------------------------------------|-------------|--------|--------|-----|--------|------|
| FSP0030FB | 135*165*14 SC (FKM)VITON | | 135 | 165 | | 14 | |
| FSP0037NB | 135*165*14 TB | 03534-13500 | 135 | 165 | | 14 | |
| FSP0009NB | 135*165*14 TC | | 135 | 165 | | 14 | |
| FSP0009FB | 135*165*14 TC(FKM)VITON | | 135 | 165 | | 14 | |
| FSP0043NB | 135*165*14/20.5 HTC9L | 9828-01168 | 135 | 165 | | 14 | 20.5 |
| FSP0105NB | 135*165*15 TB | | 135 | 165 | | 15 | |
| FSP0090NB | 135*165*15 TC | | 135 | 165 | | 15 | |
| FSP0024NB | 140*165*10 TC | | 140 | 165 | | 10 | |
| FSP0027NB | 140*165*12 SC | | 140 | 165 | | 12 | |
| FSP0087NB | 140*165*12 TB | | 140 | 165 | | 12 | |
| FSP0036NB | 140*165*12 TC | | 140 | 165 | | 12 | |
| FSP0033NB | 140*165*13 TB | | 140 | 165 | | 13 | |
| FSP0064NB | 140*165*13 TC | | 140 | 165 | | 13 | |
| FSP0064FB | 140*165*13 TC(VITON) | | 140 | 165 | | 13 | |
| FSP0085NB | 140*165*15 SC | | 140 | 165 | | 15 | |
| FSP0010NB | 140*165*15 TC | | 140 | 165 | | 15 | |
| FSP0010FB | 140*165*15 TC(VITON) | | 140 | 165 | | 15 | |
| FSP0103NB | 140*165*15 TZ | | 140 | 165 | | 15 | |
| FSP0089NB | 143*165*10 TA | | 143 | 165 | | 10 | |
| FSP0112NB | 145*165*10 TC | | 145 | 165 | | 10 | |
| FSP0060NB | 145*165*13 SA | | 145 | 165 | | 13 | |
| FSP0104NB | 145*165*13 SC | | 145 | 165 | | 13 | |
| FSP0041NB | 145*165*13 TB | | 145 | 165 | | 13 | |
| FSP0063NB | 145*165*13 TC | | 145 | 165 | | 13 | |
| FSP0063FB | 145*165*13 TC(VIOTN) | | 145 | 165 | | 13 | |
| FSP0049NB | 145*165*14 TC | | 145 | 165 | | 14 | |
| FSP0061NB | 145*165*14 TZ | | 145 | 165 | | 14 | |
| FSP0070NB | 145*165*15 SC | | 145 | 165 | | 15 | |
| FSP9986NB | 127*165.1*12.7 TA | | 127 | 165.1 | | 12.7 | |
| FSP9992NB | 127*165.1*12.7 TC | | 127 | 165.1 | | 12.7 | |
| FSP9996NB | 133.35*165.1*12.7 TA | | 133.35 | 165.1 | | 12.7 | |
| FSP9996FB | 133.35*165.1*12.7 TA (FKM) | VITON | 133.35 | 165.1 | | 12.7 | |
| FSP9995NB | 133.35*165.1*12.7 TC | | 133.35 | 165.1 | | 12.7 | |
| FSP9993NB | 133.35*165.1*14.3 TC | | 133.35 | 165.1 | | 14.3 | |
| FSP9987NB | 133.35*165.1*15.88 TA | | 133.35 | 165.1 | | 15.88 | |
| FSP9991NB | 139.7*165.1*12.7 TB | | 139.7 | 165.1 | | 12.7 | |
| FSP9998NB | 139.7*165.1*12.7 TC | | 139.7 | 165.1 | | 12.7 | |
| FSP9990NB | 142.88*165.1*12.7 TC | | 142.88 | 165.1 | | 12.7 | |
| FSP0023NB | 145*167*13 TC | | 145 | 167 | | 13 | |
| FSP0116NB | 133*168*15 KA04YL | | 133 | 168 | | 15 | |
| FSP0117NB | 142*168*13 TZ | | 142 | 168 | | 13 | |
| FSP0052NB | 142*168*14 TC | | 142 | 168 | | 14 | |
| FSP0068NB | 145*168*13 TZ | | 145 | 168 | | 13 | |
| FSP0079NB | 150*168*13 TC | | 150 | 168 | | 13 | |
| FSP0098NB | 150*168*14 TB | | 150 | 168 | | 14 | |
| FSP0074NB | 136.5*168.25*14.275 TA RED PAINTING | | 136.5 | 168.25 | | 14.275 | |
| FSP9988NB | 142.88*168.27*12.7 SC | | 142.88 | 168.27 | | 12.7 | |
| FSP9989NB | 142.88*168.27*12.7 TA | | 142.88 | 168.27 | | 12.7 | |
| FSQ9989NB | 146.05*168.27*15.88 TA | | 146.05 | 168.27 | | 15.88 | |
| FSP0086NB | 126*169*18 SC | | 126 | 169 | | 18 | |
| FSP0101NB | 95*170*13 TC | | 95 | 170 | | 13 | |
| FSP0101FB | 95*170*13 TC(VITON) | | 95 | 170 | | 13 | |
| FSP0095NB | 95*170*14 TC | | 95 | 170 | | 14 | |
| FSP0083NB | 110*170*12 TC | | 110 | 170 | | 12 | |
| FSP0083FB | 110*170*12 TC(VITON) | | 110 | 170 | | 12 | |
| FSP0075NB | 110*170*13 TC | | 110 | 170 | | 13 | |
| FSP0056NB | 110*170*15 TC | | 110 | 170 | | 15 | |

| WLK CODE | OIL SEALS | DESCRIPTION | ID | OD1 | OD2 | H1 | H2 |
|-----------|---------------------------|----------------------|-----|-----|-----|------|----|
| FSP0056FB | 110*170*15 TC(VITON) | | 110 | 170 | | 15 | |
| FSP0111NB | 120*170*15 TB | | 120 | 170 | | 15 | |
| FSP0029NB | 120*170*16 TC | | 120 | 170 | | 16 | |
| FSP0031NB | 124*170*14.5 OSC | 43090-90000(AO4389E) | 124 | 170 | | 14.5 | |
| FSP0076NB | 125*170*13 SB | | 125 | 170 | | 13 | |
| FSP0065NB | 125*170*15 TB | | 125 | 170 | | 15 | |
| FSP0054NB | 130*170*12 SC | | 130 | 170 | | 12 | |
| FSP0077NB | 130*170*12 TC | | 130 | 170 | | 12 | |
| FSP0077FB | 130*170*12 TC(VITON) | | 130 | 170 | | 12 | |
| FSP0019NB | 130*170*13 SC | | 130 | 170 | | 13 | |
| FSP0032NB | 130*170*13 TA | | 130 | 170 | | 13 | |
| FSP0080NB | 130*170*13 TC | | 130 | 170 | | 13 | |
| FSP0092NB | 130*170*14 TC | | 130 | 170 | | 14 | |
| FSP0113NB | 130*170*14/17 AXLE | | 130 | 170 | | 14 | 17 |
| FSP0082NB | 130*170*15 SC | | 130 | 170 | | 15 | |
| FSP0055NB | 130*170*15 TA | | 130 | 170 | | 15 | |
| FSP0045NB | 130*170*15 TC | | 130 | 170 | | 15 | |
| FSP0045FB | 130*170*15 TC(FKM) | | 130 | 170 | | 15 | |
| FSP0057NB | 135*170*12 SC | | 135 | 170 | | 12 | |
| FSP0057FB | 135*170*12 SC(VITON) | | 135 | 170 | | 12 | |
| FSP0046NB | 135*170*12 TC | | 135 | 170 | | 12 | |
| FSP0048NB | 135*170*13 TB | | 135 | 170 | | 13 | |
| FSP0059NB | 135*170*13 TC | | 135 | 170 | | 13 | |
| FSP0047NB | 135*170*15 TC | | 135 | 170 | | 15 | |
| FSP0100NB | 135*170*15.5 Axle | | 135 | 170 | | 15.5 | |
| FSP0015NB | 140*170*12 TC | | 140 | 170 | | 12 | |
| FSP0096NB | 140*170*13 TB | | 140 | 170 | | 13 | |
| FSP0011NB | 140*170*13 TC | | 140 | 170 | | 13 | |
| FSP0011FB | 140*170*13 TC(VITON) | | 140 | 170 | | 13 | |
| FSP0006NB | 140*170*14 TC | | 140 | 170 | | 14 | |
| FSP0006FB | 140*170*14 TC(VITON) | | 140 | 170 | | 14 | |
| FSP0115FB | 140*170*14.5/16 AXLE(FKM) | VITON | 140 | 170 | | 14.5 | 16 |
| FSP0108FB | 140*170*15 SC(VITON) | | 140 | 170 | | 15 | |
| FSP0007NB | 140*170*15 TC | | 140 | 170 | | 15 | |
| FSP0007FB | 140*170*15 TC(VITON) | | 140 | 170 | | 15 | |
| FSP0007QB | 140*170*15 TC(VMQ) | | 140 | 170 | | 15 | |
| FSP0114NB | 142*170*16 Y | | 142 | 170 | | 16 | |
| FSP0088NB | 145*170*12 SC | | 145 | 170 | | 12 | |
| FSP0066NB | 145*170*12 TC | | 145 | 170 | | 12 | |
| FSP0028NB | 145*170*13 TC | | 145 | 170 | | 13 | |
| FSP0067NB | 145*170*13 TZ(TB) | | 145 | 170 | | 13 | |
| FSP0091NB | 145*170*14 TB | | 145 | 170 | | 14 | |
| FSP0099NB | 145*170*14 TZ | | 145 | 170 | | 14 | |
| FSP0013NB | 145*170*15 TC | | 145 | 170 | | 15 | |
| FSP0013FB | 145*170*15 TC(VITON) | | 145 | 170 | | 15 | |
| FSP0071NB | 145*170*15/20 Y | | 145 | 170 | | 15 | 20 |
| FSP0072NB | 146*170*14 TB | | 146 | 170 | | 14 | |
| FSP0062NB | 146*170*18 TB | | 146 | 170 | | 18 | |
| FSP0058NB | 148*170*13 TC | | 148 | 170 | | 13 | |
| FSP0093NB | 148*170*14 TC | | 148 | 170 | | 14 | |
| FSP0109NB | 148*170*14.5 SC | | 148 | 170 | | 14.5 | |
| FSP0107NB | 148*170*15 TA | | 148 | 170 | | 15 | |
| FSP0018NB | 148*170*15 TC | | 148 | 170 | | 15 | |
| FSP0042NB | 150*170*12 SC | | 150 | 170 | | 12 | |
| FSP0039NB | 150*170*12 TC | | 150 | 170 | | 12 | |
| FSP0039FB | 150*170*12 TC(VITON) | | 150 | 170 | | 12 | |
| FSP0053NB | 150*170*13 TC | | 150 | 170 | | 13 | |

| WLK CODE | OIL SEALS | DESCRIPTION | ID | OD1 | OD2 | H1 | H2 |
|-----------|--------------------------|--------------------|--------|--------|-----|-------|------|
| FSP0008NB | 150*170*15 TA2 | | 150 | 170 | | 15 | |
| FSP0001NB | 150*170*15 TC | | 150 | 170 | | 15 | |
| FSP0001FB | 150*170*15 TC(FKM)VITON | | 150 | 170 | | 15 | |
| FSU0002N0 | 215*170*12 X3 | | 215 | 170 | | 12 | |
| FSU0001N0 | 215*170*15 X3 | | 215 | 170 | | 15 | |
| PMU0001C | 215*170*15 X3 (鐵殼) | WEAR RING | 215 | 170 | | 15 | |
| FSQ9992NB | 139.7*171.45*12.7 SB | | 139.7 | 171.45 | | 12.7 | |
| FSQ9990NB | 139.7*171.45*12.7 SC | | 139.7 | 171.45 | | 12.7 | |
| FSQ9991NB | 139.7*171.45*15.88 SA | | 139.7 | 171.45 | | 15.88 | |
| FSQ9999FB | 139.7*171.45*15.88 SC FK | FKM(VITON) | 139.7 | 171.45 | | 15.88 | |
| FSQ9997NB | 139.7*171.45*15.88 TB | | 139.7 | 171.45 | | 15.88 | |
| FSQ9996NB | 146.05*171.45*12.7 TC | | 146.05 | 171.45 | | 12.7 | |
| FSQ9998NB | 152.4*171.45*11.91 TB | 6.00*6.75*0.469 TB | 152.4 | 171.45 | | 11.91 | |
| FSQ0017NB | 150*172*12 TC | | 150 | 172 | | 12 | |
| FSQ0015NB | 150*172*13 TA | | 150 | 172 | | 13 | |
| FSQ0040NB | 150*172*15 TC | | 150 | 172 | | 15 | |
| FSQ0012NB | 154*172*14 TB | | 154 | 172 | | 14 | |
| FSQ0027NB | 154*172*14 TB3 | MC-807438 | 154 | 172 | | 14 | |
| FSQ0064NB | 155*172*13 TB | | 155 | 172 | | 13 | |
| FSQ0055NB | 155*172*14 TB | | 155 | 172 | | 14 | |
| FSQ0037NB | 155*174*12 SC | | 155 | 174 | | 12 | |
| FSQ0010NB | 155*174*12 TC | | 155 | 174 | | 12 | |
| FSO9968NB | 149.23*174.63*12.7 HSBPW | NBR80 | 149.23 | 174.63 | | 12.7 | |
| FSQ0076NB | 120*175*13 TC | | 120 | 175 | | 13 | |
| FSQ0049NB | 135*175*15 SB | | 135 | 175 | | 15 | |
| FSQ0020NB | 135*175*15 TC | | 135 | 175 | | 15 | |
| FSQ0085NB | 135*175*15.5/20 Y | | 135 | 175 | | 15.5 | 20 |
| FSQ0093NB | 135*175/205*18 AXLE | | 135 | 175 | 205 | 18 | |
| FSQ0060NB | 140*175*13 TB | | 140 | 175 | | 13 | |
| FSQ0035NB | 140*175*15 TC | | 140 | 175 | | 15 | |
| FSQ0082NB | 145*175*10 TC | | 145 | 175 | | 10 | |
| FSQ0061NB | 145*175*12 TC | | 145 | 175 | | 12 | |
| FSQ0045NB | 145*175*13 SA | | 145 | 175 | | 13 | |
| FSQ0030NB | 145*175*13 TA | | 145 | 175 | | 13 | |
| FSQ0031NB | 145*175*13 TB | | 145 | 175 | | 13 | |
| FSQ0005NB | 145*175*13 TC | | 145 | 175 | | 13 | |
| FSQ0005FB | 145*175*13 TC(VITON) | | 145 | 175 | | 13 | |
| FSQ0026NB | 145*175*14 OC(OSC) | 55515-22002 | 145 | 175 | | 14 | |
| FSQ0032NB | 145*175*14 TB | | 145 | 175 | | 14 | |
| FSQ0001NB | 145*175*14 TC | | 145 | 175 | | 14 | |
| FSQ0001FB | 145*175*14 TC(VITON) | | 145 | 175 | | 14 | |
| FSQ0070NB | 145*175*15 SC | | 145 | 175 | | 15 | |
| FSQ0070FB | 145*175*15 SC(VITON) | | 145 | 175 | | 15 | |
| FSQ0054NB | 145*175*15 TC | | 145 | 175 | | 15 | |
| FSQ0054FB | 145*175*15 TC(VITON) | | 145 | 175 | | 15 | |
| FSQ0097FB | 145*175*17/21 HTBW(FKM) | VITON | 145 | 175 | | 17 | 21 |
| FSQ0073NB | 150*175*13 TB | | 150 | 175 | | 13 | |
| FSQ0063NB | 150*175*13 TC | | 150 | 175 | | 13 | |
| FSQ0071NB | 150*175*14 TB | | 150 | 175 | | 14 | |
| FSQ0018NB | 150*175*14 TC | | 150 | 175 | | 14 | |
| FSP0017NB | 154*175*13 TB3 | 9828-01195 | 154 | 175 | | 13 | |
| FSP0106FB | 154*175*13 TZ(VITON) | | 154 | 175 | | 13 | |
| FSP0102NB | 154*175/180*13/15.5TB359 | 43090-00Z00 | 154 | 175 | 180 | 13 | 15.5 |
| FSQ0067NB | 155*175*13 TC | | 155 | 175 | | 13 | |
| FSO0117NB | 149.9*176*13.5/16 AXLE | | 149.9 | 176 | | 13.5 | 16 |
| FSQ0074NB | 155*176*16 TB | | 155 | 176 | | 16 | |
| FSQ9995NB | 146.05*177.8*15.88 SA | | 146.05 | 177.8 | | 15.88 | |

| WLK CODE | OIL SEALS | DESCRIPTION | ID | OD1 | OD2 | H1 | H2 |
|-----------|---------------------------|-----------------------|--------|-------|-----|------|------|
| FSQ9993NB | 150.81*177.8*12.7 SC | | 150.81 | 177.8 | | 12.7 | |
| FSQ0066NB | 150.83*177.8*12.7 TC | | 150.83 | 177.8 | | 12.7 | |
| FSQ9994NB | 152.4*177.8*12.7 TC | | 152.4 | 177.8 | | 12.7 | |
| FSQ0057NB | 150*178*15 OKC | | 150 | 178 | | 15 | |
| FSQ0072NB | 155*178*13 TC | | 155 | 178 | | 13 | |
| FSQ0068NB | 100*180*13 SC | | 100 | 180 | | 13 | |
| FSQ0023NB | 105*180*15 TC | | 105 | 180 | | 15 | |
| FSQ0025Q0 | 108*180*17.5 (VMQ)BLUE | BZ2374E(五孔) ME-034976 | 108 | 180 | | 17.5 | |
| FSQ0088NB | 110*180/202*12.5/49.5TCL | ZF # 0750-112-169 | 110 | 180 | 202 | 12.5 | 49.5 |
| FSQ0080NB | 110*180*15 TC | | 110 | 180 | | 15 | |
| FSQ0058NB | 115*180*12 TC | | 115 | 180 | | 12 | |
| FSQ0089NB | 115*180*15 SC | | 115 | 180 | | 15 | |
| FSQ0077NB | 120*180*13 TC | | 120 | 180 | | 13 | |
| FSQ0041NB | 120*180*15 TC | | 120 | 180 | | 15 | |
| FSQ0013NB | 130*180*15 SB | | 130 | 180 | | 15 | |
| FSQ0011NB | 130*180*15 TC | | 130 | 180 | | 15 | |
| FSQ0016NB | 135*180*15 TC | | 135 | 180 | | 15 | |
| FSQ0039NB | 140*180*12 TC | | 140 | 180 | | 12 | |
| FSQ0039FB | 140*180*12 TC(FKM)VITON | | 140 | 180 | | 12 | |
| FSQ0086NB | 140*180*13 TB | | 140 | 180 | | 13 | |
| FSQ0094NB | 140*180*13 TC | | 140 | 180 | | 13 | |
| FSR0011NB | 140*180*14 SC | | 140 | 180 | | 14 | |
| FSR0015NB | 140*180*14 TC | | 140 | 180 | | 14 | |
| FSR0015FB | 140*180*14 TC(VITON) | | 140 | 180 | | 14 | |
| FSQ0038NB | 140*180*15 TB | | 140 | 180 | | 15 | |
| FSQ0004NB | 140*180*15 TC | | 140 | 180 | | 15 | |
| FSQ0004FB | 140*180*15 TC(VITON) | | 140 | 180 | | 15 | |
| FSQ0048NB | 145*180*12 SC | | 145 | 180 | | 12 | |
| FSQ0062NB | 145*180*12 TC | | 145 | 180 | | 12 | |
| FSQ0044NB | 145*180*13 TC | | 145 | 180 | | 13 | |
| FSQ0044FB | 145*180*13 TC(VITON) | | 145 | 180 | | 13 | |
| FSQ0059NB | 145*180*14 SC | | 145 | 180 | | 14 | |
| FSQ0078NB | 145*180*14 TC | | 145 | 180 | | 14 | |
| FSQ0029NB | 145*180*15 TC | | 145 | 180 | | 15 | |
| FSQ0002NB | 150*180*12 TC | | 150 | 180 | | 12 | |
| FSQ0002FB | 150*180*12 TC(VITON) | | 150 | 180 | | 12 | |
| FSQ0090FB | 150*180*13 SA(VITON) | | 150 | 180 | | 13 | |
| FSQ0042NB | 150*180*13 SC | | 150 | 180 | | 13 | |
| FSQ0033NB | 150*180*13 TC | | 150 | 180 | | 13 | |
| FSQ0033FB | 150*180*13 TC(VITON) | | 150 | 180 | | 13 | |
| FSQ0081NB | 150*180*14 TB(TM) | | 150 | 180 | | 14 | |
| FSQ0003NB | 150*180*14 TC | | 150 | 180 | | 14 | |
| FSQ0003FB | 150*180*14 TC(VITON) | | 150 | 180 | | 14 | |
| FSQ0098FB | 150*180*14.5/16 AXLE(FKM) | VITON | 150 | 180 | | 14.5 | 16 |
| FSQ0050QB | 150*180*15 HTGL(VMQ) | | 150 | 180 | | 15 | |
| FSQ0083NB | 150*180*15 SB | | 150 | 180 | | 15 | |
| FSQ0092FB | 150*180*15 SC(VITON) | | 150 | 180 | | 15 | |
| FSQ0096NB | 150*180*15 TB | | 150 | 180 | | 15 | |
| FSQ0009NB | 150*180*15 TC | | 150 | 180 | | 15 | |
| FSQ0009FB | 150*180*15 TC(VITON) | | 150 | 180 | | 15 | |
| FSQ0009QB | 150*180*15 TC(VMQ) | | 150 | 180 | | 15 | |
| FSQ0069NB | 150*180*15 TM | | 150 | 180 | | 15 | |
| FSQ0065NB | 150*180*18 TC | | 150 | 180 | | 18 | |
| FSQ0087NB | 152*180*15 TB | | 152 | 180 | | 15 | |
| FSQ0051NB | 152.4*180*17 DC5Y | BW2410E(NOK) | 152.4 | 180 | | 17 | |
| FSQ0095NB | 155*180*12 TC | | 155 | 180 | | 12 | |
| FSQ0079NB | 155*180*14 TB | | 155 | 180 | | 14 | |

| WLK CODE | OIL SEALS | DESCRIPTION | ID | OD1 | OD2 | H1 | H2 |
|-----------|-------------------------|----------------------|--------|--------|-----|-------|----|
| FSQ0022NB | 155*180*14 TC | | 155 | 180 | | 14 | |
| FSQ0075NB | 155*180*15 SC | | 155 | 180 | | 15 | |
| FSQ0084FB | 155*180*15 TA(VITON) | | 155 | 180 | | 15 | |
| FSQ0024NB | 155*180*15 TB | | 155 | 180 | | 15 | |
| FSQ0014NB | 155*180*15 TC | | 155 | 180 | | 15 | |
| FSQ0008NB | 155*180*17 TB | MH-034081 | 155 | 180 | | 17 | |
| FSQ0007NB | 155*180*17 TC | | 155 | 180 | | 17 | |
| FSQ0056NB | 155*180*24 TBY | | 155 | 180 | | 24 | |
| FSR0010NB | 158*180*15 SC | | 158 | 180 | | 15 | |
| FSR0061NB | 158*180*15 TC | | 158 | 180 | | 15 | |
| FSQ0021NB | 160*180*10 TC | | 160 | 180 | | 10 | |
| FSQ0053NB | 160*180*10/11 TB | | 160 | 180 | | 10 | 11 |
| FSQ0028NB | 160*180*12 TC | | 160 | 180 | | 12 | |
| FSQ0034NB | 160*180*13 TB | | 160 | 180 | | 13 | |
| FSQ0043NB | 160*180*13 TC | | 160 | 180 | | 13 | |
| FSQ0043FB | 160*180*13 TC(VITON) | | 160 | 180 | | 13 | |
| FSQ0047NB | 160*180*15 SC | | 160 | 180 | | 15 | |
| FSQ0091NB | 160*180*15 TA | | 160 | 180 | | 15 | |
| FSQ0052NB | 160*180*15 TB | | 160 | 180 | | 15 | |
| FSQ0046NB | 160*180*15 TC | | 160 | 180 | | 15 | |
| FSQ0046FB | 160*180*15 TC(VITON) | | 160 | 180 | | 15 | |
| FSR0025NB | 115*180.5*13 SC | | 115 | 180.5 | | 13 | |
| FSR0055NB | 152*182*15 TC | | 152 | 182 | | 15 | |
| FSR0042NB | 160*182*17 TB | | 160 | 182 | | 17 | |
| FSR0009NB | 160*182*18 TC | | 160 | 182 | | 18 | |
| FSR0008NB | 160*182*18 TC3 | 9828-01127 | 160 | 182 | | 18 | |
| FSR0066NB | 162*182*14 TC | | 162 | 182 | | 14 | |
| FSR9997NB | 142.88*182.58*23.01 TA | | 142.88 | 182.58 | | 23.01 | |
| FSR0063NB | 123*184*16/28 TAY | | 123 | 184 | | 16 | 28 |
| FSR9998NB | 158.75*184.15*12.7 TC | 6.250*7.250*0.500 TC | 158.75 | 184.15 | | 12.7 | |
| FSR0018NB | 100*185*13 SC | | 100 | 185 | | 13 | |
| FSR0027NB | 155*185*14 TB | | 155 | 185 | | 14 | |
| FSR0012NB | 155*185*15 TC | | 155 | 185 | | 15 | |
| FSR0036NB | 160*185*10 SC | | 160 | 185 | | 10 | |
| FSR0059FB | 160*185*10 TB(VITON) | | 160 | 185 | | 10 | |
| FSR0021NB | 160*185*10 TC | | 160 | 185 | | 10 | |
| FSR0022NB | 160*185*12 TC | | 160 | 185 | | 12 | |
| FSR0013NB | 160*185*13 TC | | 160 | 185 | | 13 | |
| FSR0013FB | 160*185*13 TC(VITON) | | 160 | 185 | | 13 | |
| FSR0016NB | 160*185*14 TC | | 160 | 185 | | 14 | |
| FSR0069AB | 160*185*14.25 HSCW(ACM) | ACM | 160 | 185 | | 14.25 | |
| FSR0026NB | 160*185*15 TC | | 160 | 185 | | 15 | |
| FSR0026FB | 160*185*15 TC(VITON) | | 160 | 185 | | 15 | |
| FSR0028NB | 165*185*14 TC | | 165 | 185 | | 14 | |
| FSR0050NB | 170*185*10/14 GA | | 170 | 185 | | 10 | 14 |
| FSR0060NB | 165*186*14 TC | | 165 | 186 | | 14 | |
| FSR0001NB | 170*186*7.5/10 TCS | 日之本2800D前擔轉輪 | 170 | 186 | | 7.5 | 10 |
| FSR0040NB | 160*187.8*10 TC | | 160 | 187.8 | | 10 | |
| FSR0047NB | 160*188*12 TC | | 160 | 188 | | 12 | |
| FSR0023NB | 168*188*32 SBY | | 168 | 188 | | 32 | |
| FSR0039NB | 168*188/192*32 | | 168 | 188 | 192 | 32 | |
| FSR0045NB | 105*190*12 TC | | 105 | 190 | | 12 | |
| FSR0051NB | 130*190*12 TC | | 130 | 190 | | 12 | |
| FSR0043NB | 130*190*15 TC | | 130 | 190 | | 15 | |
| FSR0070NB | 140*190*15 TB | | 140 | 190 | | 15 | |
| FSR0024NB | 145*190*16 TA | | 145 | 190 | | 16 | |
| FSR0046NB | 145*190*16 TB | | 145 | 190 | | 16 | |

| WLK CODE | OIL SEALS | DESCRIPTION | ID | OD1 | OD2 | H1 | H2 |
|-----------|--------------------------|----------------------|--------|--------|-----|-------|----|
| FSR0038NB | 150*190*15 TB | | 150 | 190 | | 15 | |
| FSR0035NB | 150*190*15 TC | | 150 | 190 | | 15 | |
| FSR0035FB | 150*190*15 TC(VITON) | | 150 | 190 | | 15 | |
| FSR0065NB | 155*190*13 TC | | 155 | 190 | | 13 | |
| FSR0067NB | 155*190*15 SA | | 155 | 190 | | 15 | |
| FSR0049NB | 155*190*15 SB | | 155 | 190 | | 15 | |
| FSR0057NB | 155*190*15 SC | | 155 | 190 | | 15 | |
| FSR0058NB | 155*190*15 TA | | 155 | 190 | | 15 | |
| FSR0019NB | 155*190*15 TC | | 155 | 190 | | 15 | |
| FSR0019FB | 155*190*15 TC(VITON) | | 155 | 190 | | 15 | |
| FSR0020NB | 155*190*17 TB | 03434-15520 | 155 | 190 | | 17 | |
| FSR0020FB | 155*190*17 TB(VITON) | | 155 | 190 | | 17 | |
| FSR0056NB | 160*190*12 TC | | 160 | 190 | | 12 | |
| FSR0056FB | 160*190*12 TC(VITON) | | 160 | 190 | | 12 | |
| FSR0044NB | 160*190*13 SC(VITON) | | 160 | 190 | | 13 | |
| FSR0034NB | 160*190*13 TC | | 160 | 190 | | 13 | |
| FSR0034FB | 160*190*13 TC(VITON) | | 160 | 190 | | 13 | |
| FSR0033NB | 160*190*14 TC | | 160 | 190 | | 14 | |
| FSR0064FB | 160*190*15 SC(VITON) | | 160 | 190 | | 15 | |
| FSR0068FB | 160*190*15 TB(VITON) | | 160 | 190 | | 15 | |
| FSR0002NB | 160*190*15 TC | | 160 | 190 | | 15 | |
| FSR0002FB | 160*190*15 TC(VITON) | | 160 | 190 | | 15 | |
| FSR0002QB | 160*190*15 TC(VMQ) | | 160 | 190 | | 15 | |
| FSR0041NB | 160*190*16 TB(TZ) | | 160 | 190 | | 16 | |
| FSR0048NB | 160*190*16 TC | | 160 | 190 | | 16 | |
| FSR0048FB | 160*190*16 TC(VITON) | | 160 | 190 | | 16 | |
| FSR0030NB | 164*190*13 TB | | 164 | 190 | | 13 | |
| FSR0014NB | 165*190*13 TB | | 165 | 190 | | 13 | |
| FSR0052NB | 165*190*13 TC | | 165 | 190 | | 13 | |
| FSR0052FB | 165*190*13 TC(VITON) | | 165 | 190 | | 13 | |
| FSR0003NB | 165*190*15 TC | | 165 | 190 | | 15 | |
| FSR0004NB | 170*190*8.5 TC | | 170 | 190 | | 8.5 | |
| FSR0053NB | 170*190*10 TC | | 170 | 190 | | 10 | |
| FSR0029NB | 170*190*13 SC | | 170 | 190 | | 13 | |
| FSR0037NB | 170*190*13 TC | | 170 | 190 | | 13 | |
| FSR0032NB | 170*190*14 SC | | 170 | 190 | | 14 | |
| FSR0032FB | 170*190*14 SC(VITON) | | 170 | 190 | | 14 | |
| FSR0031NB | 170*190*15 SC | | 170 | 190 | | 15 | |
| FSR0054NB | 170*190*15 TA | | 170 | 190 | | 15 | |
| FSR0017NB | 170*190*15 TC | | 170 | 190 | | 15 | |
| FSS9999NB | 152.4*190.5*12.7 TA | 6.000*7.500*0.500 TA | 152.4 | 190.5 | | 12.7 | |
| FSS9996NB | 152.4*190.5*12.7 TC | | 152.4 | 190.5 | | 12.7 | |
| FSS0009NB | 161.93*190.5*12.7 TC | | 161.93 | 190.5 | | 12.7 | |
| FSS9995NB | 165.1*190.5*12.7 TB | | 165.1 | 190.5 | | 12.7 | |
| FSS9994NB | 165.1*190.5*12.7 TC | | 165.1 | 190.5 | | 12.7 | |
| FSS9994FB | 165.1*190.5*12.7 TC(FKM) | VITON | 165.1 | 190.5 | | 12.7 | |
| FSS9997FB | 165.1*190.5*14.3 SC(FKM) | | 165.1 | 190.5 | | 14.3 | |
| FSR9999NB | 155.57*193.68*19.05 TA | | 155.57 | 193.68 | | 19.05 | |
| FSS0021NB | 160*195*15 TC | | 160 | 195 | | 15 | |
| FSS0039FB | 165*195*18 SB(VITON) | | 165 | 195 | | 18 | |
| FSR0005NB | 170*195*18 TB | | 170 | 195 | | 18 | |
| FSS9998NB | 158.75*196.85*12.7 TA | | 158.75 | 196.85 | | 12.7 | |
| FSS9993NB | 165.1*196.85*12.7 TC | | 165.1 | 196.85 | | 12.7 | |
| FSR9996NB | 171.45*196.85*12.7 TC | | 171.45 | 196.85 | | 12.7 | |
| FSS0029NB | 110*200*13 TC | | 110 | 200 | | 13 | |
| FSS0027NB | 135*200*15 TC | | 135 | 200 | | 15 | |
| FSS0032NB | 150*200*13 TC | | 150 | 200 | | 13 | |

| WLK CODE | OIL SEALS | DESCRIPTION | ID | OD1 | OD2 | H1 | H2 |
|-----------|--------------------------|---------------------------|--------|--------|-----|-------|----|
| FSS0030NB | 150*200*15 TC | | 150 | 200 | | 15 | |
| FSS0031NB | 155*200*15 TC | | 155 | 200 | | 15 | |
| FSS0015NB | 155*200*20 TC | | 155 | 200 | | 20 | |
| FSR0007NB | 160*200*12 TC | | 160 | 200 | | 12 | |
| FSR0007FB | 160*200*12 TC(VITON) | | 160 | 200 | | 12 | |
| FSS0012NB | 160*200*14 TC | | 160 | 200 | | 14 | |
| FSS0018NB | 160*200*15 SB | | 160 | 200 | | 15 | |
| FSR0006NB | 160*200*15 TC | | 160 | 200 | | 15 | |
| FSR0006FB | 160*200*15 TC(VITON) | | 160 | 200 | | 15 | |
| FSS0006NB | 165*200*15 SC | | 165 | 200 | | 15 | |
| FSS0037NB | 165*200*15 TA | | 165 | 200 | | 15 | |
| FSS0007NB | 165*200*15 TC | | 165 | 200 | | 15 | |
| FSS0019NB | 170*200*12 TC | | 170 | 200 | | 12 | |
| FSS0040NB | 170*200*13 TA | | 170 | 200 | | 13 | |
| FSS0038NB | 170*200*13 TC | | 170 | 200 | | 13 | |
| FSS0013NB | 170*200*15 HTCL | | 170 | 200 | | 15 | |
| FSS0024QB | 170*200*15 HTCL(VMQ) | | 170 | 200 | | 15 | |
| FSS0014NB | 170*200*15 HTCR | | 170 | 200 | | 15 | |
| FSS0036FB | 170*200*15 SC(VITON) | | 170 | 200 | | 15 | |
| FSS0043FB | 170*200*15 TA(VITON) | | 170 | 200 | | 15 | |
| FSS010NB | 170*200*15 TB | | 170 | 200 | | 15 | |
| FSS0004NB | 170*200*15 TC | | 170 | 200 | | 15 | |
| FSS0004FB | 170*200*15 TC(VITON) | | 170 | 200 | | 15 | |
| FSS0004QB | 170*200*15 TC(VMQ) | | 170 | 200 | | 15 | |
| FSS0041FB | 170*200*16 TC(VITON) | | 170 | 200 | | 16 | |
| FSS0042NB | 170*200*17.5/21 AXLE | | 170 | 200 | | 17.5 | 21 |
| FSS0026NB | 175*200*13 TC | | 175 | 200 | | 13 | |
| FSS0011NB | 175*200*15 TC | | 175 | 200 | | 15 | |
| FSS0011FB | 175*200*15 TC(VITON) | | 175 | 200 | | 15 | |
| FSS0022NB | 178*200*15 TC | | 178 | 200 | | 15 | |
| FSS0028NB | 180*200*12 TB | | 180 | 200 | | 12 | |
| FSS0016NB | 180*200*12 TC | | 180 | 200 | | 12 | |
| FSS0033NB | 180*200*12 TGB | | 180 | 200 | | 12 | |
| FSS003NB | 180*200*13 SC | | 180 | 200 | | 13 | |
| FSS0023NB | 180*200*13 TB | | 180 | 200 | | 13 | |
| FSS0010NB | 180*200*13 TC | | 180 | 200 | | 13 | |
| FSS0010FB | 180*200*13 TC(VITON) | | 180 | 200 | | 13 | |
| FSS0002NB | 180*200*14 TC | | 180 | 200 | | 14 | |
| FSS0001NB | 180*200*15 SA2 | | 180 | 200 | | 15 | |
| FSS0035NB | 180*200*15 TA | | 180 | 200 | | 15 | |
| FSS0034NB | 180*200*15 TB | | 180 | 200 | | 15 | |
| FSS0008NB | 180*200*15 TC | | 180 | 200 | | 15 | |
| FSS0017NB | 180*200*17 TC | | 180 | 200 | | 17 | |
| FST9995NB | 174.63*200.02*15.88 TA | | 174.63 | 200.02 | | 15.88 | |
| FST9998NB | 165.1*203.2*12.7 TA | | 165.1 | 203.2 | | 12.7 | |
| FST0002NB | 177.8*203.2*12.7 SC | 7.000*8.000*0.500 SC | 177.8 | 203.2 | | 12.7 | |
| FST0009NB | 177.8*203.2*12.7 TC | 7.000*8.000*0.500 TC | 177.8 | 203.2 | | 12.7 | |
| FST0009FB | 177.8*203.2*12.7 TC(FKM) | 7.000*8.000*0.500 TC(FKM) | 177.8 | 203.2 | | 12.7 | |
| FST9992NB | 177.8*203.2*15.88 SA | | 177.8 | 203.2 | | 15.88 | |
| FST0007NB | 170*205*15 TC | | 170 | 205 | | 15 | |
| FST0023NB | 170*205*18 SC | | 170 | 205 | | 18 | |
| FST0017NB | 175*205*15 SC | | 175 | 205 | | 15 | |
| FST0018NB | 175*205*15 TB | | 175 | 205 | | 15 | |
| FST0013NB | 175*205*15 TC | | 175 | 205 | | 15 | |
| FST0024NB | 180*205*15 HTBGL(BROWN) | | 180 | 205 | | 15 | |
| FST0001NB | 190*206*9.2 TCS | 日之本41Hp前擔轉輪 | 190 | 206 | | 9.2 | |
| FST9997NB | 168.28*206.38*15.88 TA | | 168.28 | 206.38 | | 15.88 | |

| WLK CODE | OIL SEALS | DESCRIPTION | ID | OD1 | OD2 | H1 | H2 |
|-----------|--------------------------|-------------|--------|--------|-----|-------|-----|
| FST9993NB | 171.45*209.55*15.88 TA | | 171.45 | 209.55 | | 15.88 | |
| FST9996NB | 177.8*209.55*19.05 TA | | 177.8 | 209.55 | | 19.05 | |
| FST0010NB | 150*210*15 TC | | 150 | 210 | | 15 | |
| FST0010FB | 150*210*15 TC(FKM)VITON | | 150 | 210 | | 15 | |
| FST0022NB | 160*210*15 TC | | 160 | 210 | | 15 | |
| FSU0006NB | 170*210*15 TA | | 170 | 210 | | 15 | |
| FSS0005NB | 170*210*15 TC | | 170 | 210 | | 15 | |
| FST0008NB | 170*210*20 MG軟 | | 170 | 210 | | 20 | |
| FST0011NB | 175*210*15 TC | | 175 | 210 | | 15 | |
| FST0026FB | 180*210*8.5/9.5 TCV(FKM) | VITON | 180 | 210 | | 8.5 | 9.5 |
| FST0014NB | 180*210*13 TC | | 180 | 210 | | 13 | |
| FST0012NB | 180*210*15 SC | | 180 | 210 | | 15 | |
| FST0006NB | 180*210*15 TB | | 180 | 210 | | 15 | |
| FST0003NB | 180*210*15 TC | | 180 | 210 | | 15 | |
| FST0028FB | 180*210*16 TC(VITON) | | 180 | 210 | | 16 | |
| FST0005NB | 185*210*13 TC | | 185 | 210 | | 13 | |
| FSU0008NB | 185*210*15 TC | | 185 | 210 | | 15 | |
| FST0016NB | 190*210*15 TA | | 190 | 210 | | 15 | |
| FSU0024NB | 110*215*15 TC | | 110 | 215 | | 15 | |
| FSU0025NB | 175*215*15 TC | | 175 | 215 | | 15 | |
| FSU0026NB | 178*215*16 SC | | 178 | 215 | | 16 | |
| FSU0033NB | 180*215*15 TB | | 180 | 215 | | 15 | |
| FSU0009NB | 180*215*15 TC | | 180 | 215 | | 15 | |
| FSU0019NB | 180*215*16 SC | | 180 | 215 | | 16 | |
| FSU0010NB | 180*215*16 TC | | 180 | 215 | | 16 | |
| FST0027NB | 185*215*15 TA | | 185 | 215 | | 15 | |
| FST0027FB | 185*215*15 TA(VITON) | | 185 | 215 | | 15 | |
| FST0015NB | 185*215*15 TB | | 185 | 215 | | 15 | |
| FST0004NB | 185*215*15 TC | | 185 | 215 | | 15 | |
| FST0020NB | 185*215*16 TC | | 185 | 215 | | 16 | |
| FSU0017NB | 188*215*15 TB | | 188 | 215 | | 15 | |
| FSU0011NB | 190*215*15 SC | | 190 | 215 | | 15 | |
| FSU0035NB | 190*215*15 TC | | 190 | 215 | | 15 | |
| FSU0005NB | 190*215*16 TC | | 190 | 215 | | 16 | |
| FSU9999NB | 177.8*215.9*12.7 TC | | 177.8 | 215.9 | | 12.7 | |
| FST9994NB | 190.5*215.9*15.88 TA | | 190.5 | 215.9 | | 15.88 | |
| FST0025NB | 190.5*215.9*15.88 TB | | 190.5 | 215.9 | | 15.88 | |
| FSU0023NB | 170*220*15 TC | | 170 | 220 | | 15 | |
| FSU0034NB | 180*220*12 TC | | 180 | 220 | | 12 | |
| FSU0018NB | 180*220*15 SC | | 180 | 220 | | 15 | |
| FSU0028NB | 180*220*15 TB | | 180 | 220 | | 15 | |
| FSU0003NB | 180*220*15 TC | | 180 | 220 | | 15 | |
| FSU0031NB | 180*220*16 SC | | 180 | 220 | | 16 | |
| FSU0015NB | 180*220*16 TC | | 180 | 220 | | 16 | |
| FSU0022NB | 185*220*15 SC | | 185 | 220 | | 15 | |
| FSU0012NB | 185*220*15 TC | | 185 | 220 | | 15 | |
| FSU0013NB | 190*220*13 TC | | 190 | 220 | | 13 | |
| FSU0013FB | 190*220*13 TC(FKM) | | 190 | 220 | | 13 | |
| FSU0020NB | 190*220*15 SC | | 190 | 220 | | 15 | |
| FSU0004NB | 190*220*15 TC | | 190 | 220 | | 15 | |
| FSU0004FB | 190*220*15 TC(VITON) | | 190 | 220 | | 15 | |
| FSU0021NB | 190*220*16 SA | | 190 | 220 | | 16 | |
| FSU0027NB | 190*220*16 TC | | 190 | 220 | | 16 | |
| FSU0036NB | 190*220*20 TC | | 190 | 220 | | 20 | |
| FSU0032NB | 195*220*16 TA | | 195 | 220 | | 16 | |
| FSU0014NB | 195*220*16 TB | | 195 | 220 | | 16 | |
| FSU0007NB | 195*220*16 TC | | 195 | 220 | | 16 | |

| WLK CODE | OIL SEALS | DESCRIPTION | ID | OD1 | OD2 | H1 | H2 |
|-----------|------------------------|-------------------|--------|--------|-----|-------|----|
| FSU0007FB | 195*220*16 TC(VITON) | | 195 | 220 | | 16 | |
| FSU0029N | 200*220*15 TC | | 200 | 220 | | 15 | |
| FSV0006NB | 184.15*222.25*14.3 SC | | 184.15 | 222.25 | | 14.3 | |
| FSV0027NB | 184.15*222.25*14.3 TC | | 184.15 | 222.25 | | 14.3 | |
| FSV9997NB | 184.15*222.25*19.05 TA | | 184.15 | 222.25 | | 19.05 | |
| FSV0025NB | 150*225*15 TC | | 150 | 225 | | 15 | |
| FSU0037NB | 180*225*15 TB | | 180 | 225 | | 15 | |
| FSV0015NB | 190*225*13 TC | | 190 | 225 | | 13 | |
| FSV0017NB | 190*225*15 TC | | 190 | 225 | | 15 | |
| FSV0017FB | 190*225*15 TC(VITON) | | 190 | 225 | | 15 | |
| FSV0028NB | 190*225*16 SA | | 190 | 225 | | 16 | |
| FSV0026NB | 190*225*16 SC | | 190 | 225 | | 16 | |
| FSV0010NB | 190*225*16 TB | | 190 | 225 | | 16 | |
| FSV0002NB | 190*225*16 TC | | 190 | 225 | | 16 | |
| FSU0016NB | 195*225*15 TC | | 195 | 225 | | 15 | |
| FSV0009NB | 200*225*15 TC | | 200 | 225 | | 15 | |
| FSV0007NB | 190.5*228.6*15.75 TB | 7.50*9.00*0.62 TB | 190.5 | 228.6 | | 15.75 | |
| FSV9998NB | 190.5*228.6*15.88 TA | | 190.5 | 228.6 | | 15.88 | |
| FSV0018NB | 190.5*228.6*15.88 TB | | 190.5 | 228.6 | | 15.88 | |
| FSV9999NB | 190.5*228.6*19.05 TA | | 190.5 | 228.6 | | 19.05 | |
| FSV0016NB | 200.8*228.6*15 Y | | 200.8 | 228.6 | | 15 | |
| FSV9996NB | 203.2*228.6*15.88 TA | | 203.2 | 228.6 | | 15.88 | |
| FSV0022NB | 180*230*17 TC | | 180 | 230 | | 17 | |
| FSV0021NB | 190*230*15 SC | | 190 | 230 | | 15 | |
| FSV0012NB | 190*230*15 TC | | 190 | 230 | | 15 | |
| FSV0012FB | 190*230*15 TC(VITON) | | 190 | 230 | | 15 | |
| FSV0023NB | 190*230*16 TB | | 190 | 230 | | 16 | |
| FSV0005NB | 190*230*16 TC | | 190 | 230 | | 16 | |
| FSV0003NB | 195*230*15 TC | | 195 | 230 | | 15 | |
| FSU0030NB | 195*230*17 SC | | 195 | 230 | | 17 | |
| FSV0024NB | 200*230*15 TB | | 200 | 230 | | 15 | |
| FSV0001NB | 200*230*15 TC | | 200 | 230 | | 15 | |
| FSV0001FB | 200*230*15 TC (VITON) | | 200 | 230 | | 15 | |
| FSV0001QB | 200*230*15 TC (VMQ) | | 200 | 230 | | 15 | |
| FSV0029NB | 200*230*16 TC | | 200 | 230 | | 16 | |
| FSV0014NB | 205*230*15 SC | | 205 | 230 | | 15 | |
| FSV0011NB | 205*230*15 TC | | 205 | 230 | | 15 | |
| FSV0008NB | 205*230*16 SC | | 205 | 230 | | 16 | |
| FSW0017NB | 203.2*234.95*15.88 TA | | 203.2 | 234.95 | | 15.88 | |
| FSV0020NB | 195*235*15 TC | | 195 | 235 | | 15 | |
| FSV0013NB | 200*235*15 TC | | 200 | 235 | | 15 | |
| FSV0004NB | 200*235*16 TC | | 200 | 235 | | 16 | |
| FSW0002NB | 160*240*15 TC | | 160 | 240 | | 15 | |
| FSW0007NB | 190*240*15 TC | | 190 | 240 | | 15 | |
| FSW0006NB | 190*240*18 TC | | 190 | 240 | | 18 | |
| FSW0003NB | 195*240*15 TC | | 195 | 240 | | 15 | |
| FSW0004NB | 200*240*15 SC | | 200 | 240 | | 15 | |
| FSW0005NB | 200*240*15 TC | | 200 | 240 | | 15 | |
| FSW0001NB | 200*240*18 TC | | 200 | 240 | | 18 | |
| FSW0009NB | 200*240*20 TC | | 200 | 240 | | 20 | |
| FSX0015FB | 210*240*15 SC(VITON) | | 210 | 240 | | 15 | |
| FSX0004NB | 210*240*15 TC | | 210 | 240 | | 15 | |
| FSX0004FB | 210*240*15 TC(VITON) | | 210 | 240 | | 15 | |
| FSX0012NB | 215*240*12 TC | | 215 | 240 | | 12 | |
| FSW0008NB | 220*240*15 TC | | 220 | 240 | | 15 | |
| FSX9999NB | 203.2*241.3*14.28 SC | | 203.2 | 241.3 | | 14.28 | |
| FSX0013NB | 203.2*241.3*14.3 TC | | 203.2 | 241.3 | | 14.3 | |

| WLK CODE | OIL SEALS | DESCRIPTION | ID | OD1 | OD2 | H1 | H2 |
|-----------|----------------------|--------------------|-------|-----|-----|--------|----|
| FSX0005NB | 190*245*24.5 TC | | 190 | 245 | | 24.5 | |
| FSX0006NB | 195*250*22 SB | | 195 | 250 | | 22 | |
| FSX0016NB | 200*250*15 SA | | 200 | 250 | | 15 | |
| FSX0014NB | 200*250*15 TA | | 200 | 250 | | 15 | |
| FSX0002NB | 200*250*15 TC | | 200 | 250 | | 15 | |
| FSX0002FB | 200*250*15 TC(VITON) | | 200 | 250 | | 15 | |
| FSX0019NB | 200*250*16 SC | | 200 | 250 | | 16 | |
| FSX0011NB | 210*250*15 SC | | 210 | 250 | | 15 | |
| FSX0010NB | 210*250*15 TC | | 210 | 250 | | 15 | |
| FSX0003NB | 210*250*16 TC | | 210 | 250 | | 16 | |
| FSX0021FB | 215*250*12 TC(VITON) | | 215 | 250 | | 12 | |
| FSX0008NB | 215*250*16 TC | | 215 | 250 | | 16 | |
| FSX0009NB | 220*250*15 SC | | 220 | 250 | | 15 | |
| FSX0017NB | 220*250*15 TA | | 220 | 250 | | 15 | |
| FSX0001NB | 220*250*15 TC | | 220 | 250 | | 15 | |
| FSX0001FB | 220*250*15 TC(VITON) | | 220 | 250 | | 15 | |
| FSX0018FB | 220*250*16 TC(VITON) | | 220 | 250 | | 16 | |
| FSX0007NB | 225*250*15 SC | | 225 | 250 | | 15 | |
| FSX0020FB | 225*250*16 SA(VITON) | | 225 | 250 | | 16 | |
| FSY9999NB | 203.2*254*15.748 SC | 8.00*10.00*0.62 SC | 203.2 | 254 | | 15.748 | |
| FSY0004NB | 203.2*254*15.87 TB | | 203.2 | 254 | | 15.87 | |
| FSY9997NB | 203.2*254*15.88 TA | | 203.2 | 254 | | 15.88 | |
| FSY9996NB | 215.9*254*19.05 TC | | 215.9 | 254 | | 19.05 | |
| FSY9998NB | 228.6*254*10.922 SC | 9.00*10.00*0.43 SC | 228.6 | 254 | | 10.922 | |
| FSV9995NB | 228.6*254*15.88 TA | | 228.6 | 254 | | 15.88 | |
| FSY9995NB | 228.6*254*19.05 SB | | 228.6 | 254 | | 19.05 | |
| FSV0019NB | 200*255*15 TB | | 200 | 255 | | 15 | |
| FSY0009NB | 230*255*10 TC | | 230 | 255 | | 10 | |
| FSY0006NB | 228.6*258*17 TB | | 228.6 | 258 | | 17 | |
| FSY0005NB | 220*260*15 TC | | 220 | 260 | | 15 | |
| FSY0008NB | 220*260*16 TC | | 220 | 260 | | 16 | |
| FSY0001NB | 220*260*19 TC | | 220 | 260 | | 19 | |
| FSZ0015NB | 220*260*20 TC | | 220 | 260 | | 20 | |
| FSZ0070NB | 220*260*22 TC | | 220 | 260 | | 22 | |
| FSY0003NB | 230*260*15 SC | | 230 | 260 | | 15 | |
| FSY0002NB | 230*260*15 TC | | 230 | 260 | | 15 | |
| FSY0007NB | 230*260*16 TC | | 230 | 260 | | 16 | |
| FSZ0078NB | 235*265*15 SC | | 235 | 265 | | 15 | |
| FSZ0048NB | 220*270*15 SB | | 220 | 270 | | 15 | |
| FSZ0062NB | 220*270*15 TC | | 220 | 270 | | 15 | |
| FSZ0087NB | 230*270*15 SA | | 230 | 270 | | 15 | |
| FSZ0049NB | 230*270*16 SC | | 230 | 270 | | 16 | |
| FSZ0076NB | 230*270*16 TB | | 230 | 270 | | 16 | |
| FSZ0014NB | 230*270*16 TC | | 230 | 270 | | 16 | |
| FSZ0044NB | 235*270*16 TC | | 235 | 270 | | 16 | |
| FSZ0009NB | 240*270*15 SC | | 240 | 270 | | 15 | |
| FSZ0009FB | 240*270*15 SC(VITON) | | 240 | 270 | | 15 | |
| FSZ0008NB | 240*270*15 TC | | 240 | 270 | | 15 | |
| FSZ0032NB | 240*270*16 TB | | 240 | 270 | | 16 | |
| FSZ0027NB | 240*270*16 TC | | 240 | 270 | | 16 | |
| FSZ0030NB | 220*275*23 TC | | 220 | 275 | | 23 | |
| FSZ0052NB | 230*280*15 TA | | 230 | 280 | | 15 | |
| FSZ0060NB | 230*280*16 TA | | 230 | 280 | | 16 | |
| FSZ0077NB | 240*280*15 SC | | 240 | 280 | | 15 | |
| FSZ0036NB | 240*280*15 TC | | 240 | 280 | | 15 | |
| FSZ0002NB | 240*280*16 TC | | 240 | 280 | | 16 | |
| FSZ0018NB | 240*280*20 TC | | 240 | 280 | | 20 | |

| WLK CODE | OIL SEALS | DESCRIPTION | ID | OD1 | OD2 | H1 | H2 |
|------------|------------------------|---------------------|--------|--------|-----|-------|----|
| FSZ0046NB | 250*280*15 SC | | 250 | 280 | | 15 | |
| FSZ0046FB | 250*280*15 SC(VITON) | | 250 | 280 | | 15 | |
| FSZ0013NB | 250*280*15 TC | | 250 | 280 | | 15 | |
| FSZ0013FB | 250*280*15 TC(VITON) | | 250 | 280 | | 15 | |
| FSZ0050NB | 250*280*16 SC | | 250 | 280 | | 16 | |
| FSZ0012NB | 250*280*16 TC | | 250 | 280 | | 16 | |
| FSZ0012FB | 250*280*16 TC(VITON) | | 250 | 280 | | 16 | |
| FSZ0055NB | 250*285*18 TC | | 250 | 285 | | 18 | |
| FSZ0098NB | 255*285*16 TC | | 255 | 285 | | 16 | |
| FSZ9999NB | 234.95*285.75*15.88 TA | 9.25*11.25*0.625 TA | 234.95 | 285.75 | | 15.88 | |
| FSZ0051NB | 250*290*15 TB | | 250 | 290 | | 15 | |
| FSZ0035NB | 250*290*15 TC | | 250 | 290 | | 15 | |
| FSZ0037NB | 260*290*15 SC | | 260 | 290 | | 15 | |
| FSZ0053NB | 260*290*15 TC | | 260 | 290 | | 15 | |
| FSZ0061NB | 260*290*16 SA | | 260 | 290 | | 16 | |
| FSZ0028NB | 260*290*16 TC | | 260 | 290 | | 16 | |
| FSZ0003NB | 260*290*18 TC | | 260 | 290 | | 18 | |
| FSZ0095NB | 265*290*16 SC | | 265 | 290 | | 16 | |
| FSZ0001NB | 225*300*37 SC | | 225 | 300 | | 37 | |
| FSZ0066NB | 260*300*16 TC | | 260 | 300 | | 16 | |
| FSZ0088NB | 260*300*18 SC | | 260 | 300 | | 18 | |
| FSZ0045NB | 260*300*18 TC | | 260 | 300 | | 18 | |
| FSZ0039NB | 260*300*20 SA | | 260 | 300 | | 20 | |
| FSZ0004NB | 260*300*20 TA | | 260 | 300 | | 20 | |
| FSZ0016NB | 260*300*20 TC | | 260 | 300 | | 20 | |
| FSZ0016FB | 260*300*20 TC(VITON) | | 260 | 300 | | 20 | |
| FSZ0021NB | 270*310*20 TC | | 270 | 310 | | 20 | |
| FSZ0056NB | 275*310*16 TC | | 275 | 310 | | 16 | |
| FSZ0094NB | 280*310*15 SC | | 280 | 310 | | 15 | |
| FSZ0023NB | 280*310*16 TC | | 280 | 310 | | 16 | |
| FSZ0081NB | 280*310*18 TC | | 280 | 310 | | 18 | |
| FSZ0043NB | 260*315*24 TC | | 260 | 315 | | 24 | |
| FSZ9997NB | 285.75*317.5*15.88 TA | | 285.75 | 317.5 | | 15.88 | |
| FSZ0007NB | 280*320*18 TC | | 280 | 320 | | 18 | |
| FSZ0031NB | 280*320*20 SC | | 280 | 320 | | 20 | |
| FSZ0031FB | 280*320*20 SC(VITON) | | 280 | 320 | | 20 | |
| FSZ0082NB | 280*320*20 TA | | 280 | 320 | | 20 | |
| FSZ0058NB | 280*320*20 TC | | 280 | 320 | | 20 | |
| FSZ0058FB | 280*320*20 TC(VITON) | | 280 | 320 | | 20 | |
| FSZ0065FB | 295*325*16 TC | | 295 | 325 | | 16 | |
| FSZ0038NB | 295*325*17 TB | | 295 | 325 | | 17 | |
| FSZ0092NB | 270*330*25 TB | | 270 | 330 | | 25 | |
| FSZ0085NB | 290*330*18 SA | | 290 | 330 | | 18 | |
| FSZ0047NB | 290*330*18 TC | | 290 | 330 | | 18 | |
| FSZ0071NB | 300*335*18 TB | | 300 | 335 | | 18 | |
| FSZ0089NB | 300*340*16 TC | | 300 | 340 | | 16 | |
| FSZ0101FB | 300*340*18 SC(VITON) | | 300 | 340 | | 18 | |
| FSZ0011NB | 300*340*18 TB | | 300 | 340 | | 18 | |
| FSZ0017NB | 300*340*18 TC | | 300 | 340 | | 18 | |
| FSZ0017FB | 300*340*18 TC(VITON) | | 300 | 340 | | 18 | |
| FSZ0097FB | 300*340*20 SC(VITON) | | 300 | 340 | | 20 | |
| FSZ0083NB | 300*340*20 TB | | 300 | 340 | | 20 | |
| FSZ0086NB | 300*340*20 TC | | 300 | 340 | | 20 | |
| FSAZ0086FB | 300*340*20 TC(VITON) | | 300 | 340 | | 20 | |
| FSZ0080NB | 315*355*20 TC | | 315 | 355 | | 20 | |
| FSZ0033NB | 320*360*18 TC | | 320 | 360 | | 18 | |
| FSZ0073NB | 330*360*18 TA | | 330 | 360 | | 18 | |

| WLK CODE | OIL SEALS | DESCRIPTION | ID | OD1 | OD2 | H1 | H2 |
|-----------|-------------------------|-------------|-------|-------|-----|-------|----|
| FSZ0020NB | 330*360*20 TC | (WLK商標) | 330 | 360 | | 20 | |
| FSZ0063NB | 330*370*18 TC | | 330 | 370 | | 18 | |
| FSZ0072NB | 340*372*16 TC | | 340 | 372 | | 16 | |
| FSZ0040NB | 320*380*25 TA | | 320 | 380 | | 25 | |
| FSZ0067NB | 340*380*18 TC | | 340 | 380 | | 18 | |
| FSZ0075NB | 340*380*20 TB | | 340 | 380 | | 20 | |
| FSZ0057NB | 340*380*20 TC | | 340 | 380 | | 20 | |
| FSZ0057FB | 340*380*20 TC(VITON) | | 340 | 380 | | 20 | |
| FSZ0100FB | 330*390*28 TB(VITON) | | 330 | 390 | | 28 | |
| FSZ0074NB | 350*390*18 TC | | 350 | 390 | | 18 | |
| FSZ0103NB | 360*400*18 TA | | 360 | 400 | | 18 | |
| FSZ0026NB | 360*400*20 TC | | 360 | 400 | | 20 | |
| FSZ0026FB | 360*400*20 TC(FKM)VITON | | 360 | 400 | | 20 | |
| FSZ0010NB | 360*420*25 TC | | 360 | 420 | | 25 | |
| FSZ0041NB | 380*420*20 TA | | 380 | 420 | | 20 | |
| FSZ0091NB | 380*420*20 TC(VITON) | | 380 | 420 | | 20 | |
| FSZ0059NB | 380*420*20 TC6 | | 380 | 420 | | 20 | |
| FSZ0090NB | 394*420*16 TC | | 394 | 420 | | 16 | |
| FSZ0096NB | 400*440*18 TA | | 400 | 440 | | 18 | |
| FSZ0034NB | 400*440*18 TC | | 400 | 440 | | 18 | |
| FSZ0029NB | 400*440*20 SM | | 400 | 440 | | 20 | |
| FSZ0102NB | 400*440*20 TA | | 400 | 440 | | 20 | |
| FSZ0069NB | 400*440*20 TC | | 400 | 440 | | 20 | |
| FSZ9998NB | 406.4*457.2*20.65 SC | | 406.4 | 457.2 | | 20.65 | |
| FSZ0042NB | 440*480*20 TB | | 440 | 480 | | 20 | |
| FSZ0064NB | 440*480*20 TC | | 440 | 480 | | 20 | |
| FSZ0079NB | 460*500*20 TC | | 460 | 500 | | 20 | |
| FSZ0022NB | 500*560*20 SC | | 500 | 560 | | 20 | |
| FSZ0099FB | 530*580*20 TA(VITON) | | 530 | 580 | | 20 | |
| FSZ0024NB | 558.8*596.9*19 SB(SM) | | 558.8 | 596.9 | | 19 | |
| FSZ0084NS | 560*610*20 TC(S304) | | 560 | 610 | | 20 | |
| FSZ0025NB | 580*640*25 SB(SZ) | | 580 | 640 | | 25 | |
| FSZ0093NB | 710*760*20 TA | | 710 | 760 | | 20 | |

Catalogue for U Seals

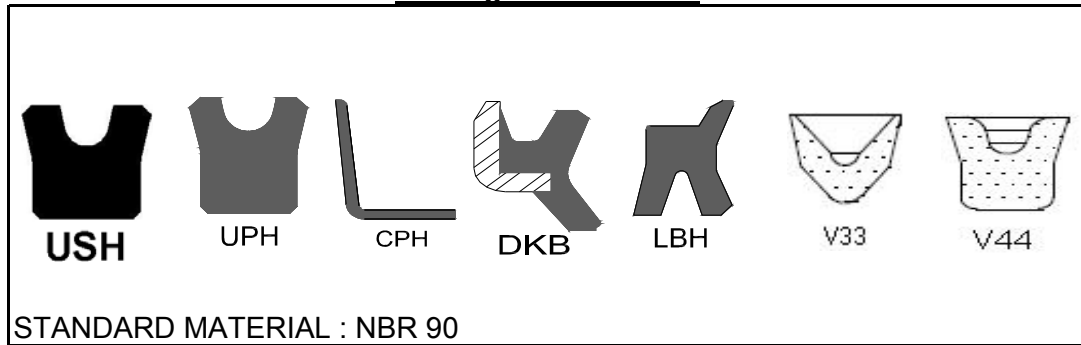

STANDARD MATERIAL : NBR 90

| WLK CODE | DESCRIPTION | REMARKS |
|-----------|-------------------------|-----------------|
| FPUC0300N | 4*12*5 USH(NBR80) | |
| FPD90012N | 12*16*3/4 LBH | NBR90 |
| FPUC1218U | 12*18*5 USH(NBR90)黑膠 | |
| FPD91420N | 14*20*4.5/6 LBH(NBR90度) | |
| FSB0179N0 | 12*22*10 USH | NBR90度 |
| FPD51422N | 14*22*4/5.5 DKB(NBR90) | |
| FPUC0011N | 19*27*5 USH (NBR90度) | |
| FPD92028N | 20*28*4.5/6 LBH(NBR90) | |
| FPD90005N | 20*28*5/7 LBH | 新模 |
| FPUC2028N | 20*28*5 USH(NBR90) | 黑色 |
| FPUC2005N | 20*30*5 USH(NBR90深綠色) | |
| FPUC2030N | 20*30*10 USH(NBR90深綠) | |
| FPUC0012N | 22*30*5 USH NBR90 | SKY-22 |
| FPUC2230N | 22*30*10 USH(NBR90深綠色) | |
| FPD51931N | 19*31*6/9 DKB(NBR85度) | |
| FPUC0026N | 22*31*5 USH (NBR90度) | |
| FPUC2231N | 22*31*5 USH+S(NBR90) | 內徑21+/-0.20 |
| FPUC0027N | 23*31*5 USH+S | 刻字RSU 23-31無WLK |
| FPD52032N | 20*32*6/9 DKB(NBR85度) | |
| FSC0166N0 | 22*32*5 USH(V軟)NBR90 | |
| FSC0163N0 | 22*32*6/9 DKB(NBR90) | 僅刻字BR3178E無WLK |
| FPUC0296N | 24*32*5 USH(NBR90) | |
| FPUC2233N | 22*33*6 USH(NBR90) | |
| FPD92533N | 25*33*4.5/6 LBH | |
| FPUB0005N | 25*33*5 USH NBR90 | SKY-25 |
| FPD52234N | 22*34*6/9 DKB | |
| FPUC2834N | 28*34.8*5 USH(NBR90度) | |
| FPUC2235N | 22*35*8 USH深綠(NBR90度) | |
| FPD90025N | 25*35*5/6.5 LBH | NBR90度深綠色 |
| FPUC2535N | 25*35*6 USH NBR90度 | |
| FSC0927NB | 25*35*6/9 DKB(NBR90) | 新模 |
| FPUC0017N | 25*35*8 USH (NBR90度) | |
| FPUC2735N | 27*35*5 USH(NBR90) | |
| FPD52537N | 25*37*6/9 DKB | 僅刻AR1301H不要WLK |
| FPD90020N | 20*38*5/7 LBH(NBR90)黑色 | NBR90 新模 |
| FPUC0025N | 25*38*6 USH | NBR 90度 |
| FPUC2538N | 25*38*10 USH(NBR90深綠色) | |
| FPD90030N | 30*38*5/6.5 LBH | |
| FPUC0002N | 31*38*5 USH(NBR90度) | |

| WLK CODE | DESCRIPTION | REMARKS |
|------------|-------------------------|----------------|
| FPD90006N | 30*38.5*6 LBH | NBR90 |
| FPUC2540N | 25*40*7 USH(NBR90深綠色) | |
| FPUB2540N | 25*40*10 UPH(NBR90度) | 深綠色;黑色 |
| FPUC3040N | 30*40*6 USH | 刻字USH-30;NBR90 |
| FPUC3008N | 30*40*8 USH黑膠NBR90 | |
| FPUC3240N | 32*40*5 USH(NBR90度) | |
| FSD0697NB | 30*41*7/8.5 LBH(NBR90)黑 | |
| FPUC3241N | 32*41*5 USH軟 | (NBR90度) |
| FPUC3201N | 32*41*10 USH(NBR90)黑膠 | |
| FPD52542N | 25*42*6/9 DKB | 僅刻BR3431E不要WLK |
| FPD53042N | 30*42*6/9 DKB(NBR90) | 僅刻AR1664F無WLK |
| FPUC3007N | 30*42*7 USH(NBR90)黑膠 | |
| FPUC3042N | 30*42*10 USH | |
| FPUC0004N | 32*42*5 USH(NBR90度) | |
| FPUC3242N | 32*42*6 USH(NBR90) | |
| FPUC3208N | 32*42*8 USH黑膠NBR90 | |
| FPUC3210N | 32*42*10 USH(NBR90度黑色) | |
| FPD93543N | 35*43*5/6.5 LBH(NBR90度) | |
| FPD53244N | 32*44*7/10 DKB | |
| FPD53045N | 30*45*6/9 DKB(NBR90) | |
| FPUC3245N | 32*45*6 USH深綠色 | |
| FPUC3207N | 32*45*7 USH(NBR90度) | |
| FSD0175NB | 35*45*5/7 OSI | |
| FPUC3506N | 35*45*6 USH黑膠NBR90 | |
| FPUC3545N | 35*45*10 USH深綠色NBR90 | |
| FSD0710NB | 30*47*7/10 DKB | |
| FPUC3247N | 32*47*8 USH(NBR90)黑膠 | |
| FPD90035N | 35*47*7/9 LBH | LBH35A |
| FSD0536N0 | 35*47*7/10 DKB | |
| FPUC3548N | 35*48*7 USH深綠NBR90度 | |
| FPUC3508N | 35*48*8 USH黑膠NBR90 | |
| FPUC3510N | 35*48*10 USH黑膠NBR90 | |
| FPUC3807N | 38*48*7 USH(NBR90度) | |
| FPUC3050N | 30*50*10 USH(NBR90深綠色) | |
| FPUC0081N | 35*50*8 USH黑膠(NBR90) | |
| FPUB0002N | 35*50*10 USH NBR90度 | 無商標 |
| FPUC3850N | 38*50*6 USH NBR90度 | |
| FPUC4050N | 40*50*6 USH NBR90 | SKY-40深綠色;黑色 |
| FPUC4007N | 40*50*7 USH深綠NBR90度 | |
| FPUC4008N | 40*50*8 USH(深綠NBR90度) | |
| FPUC0013N | 40*50*10 USH (NBR90度) | |
| FSE0512N0 | 40*52*7/10 DKB | 無商標 |
| FPD84553N | 45*53*5/6.5 LBH(NBR黑色) | |
| FPUC4055N | 40*55*10 USH(NBR90黑色) | |
| FPUC4255N | 42*55*8 USH(Green) | |
| FPD845555N | 45*55*6/8 LBH(NBR90黑膠) | |
| FPUC4506N | 45*55*6 USH黑膠NBR90 | |
| FPU04507N | 45*55*7 USH(NBR90)黑膠 | |
| FPUC4510N | 45*55*10 USH(NBR90度黑) | |
| FPUC4056N | 40*56*6 USH(NBR90黑色) | |
| FPUC0015N | 45*56*7 USH NBR90 | SKY-45A |

| WLK CODE | DESCRIPTION | REMARKS |
|-----------|---------------------------|----------------|
| FPUC4556N | 45*56*8 USH(NBR90度) | |
| FPD54557N | 45*57*7/10 DKB(NBR90) | 僅刻字AR2633G無WLK |
| FPUC4058N | 40*58*10 USH(深綠色) | |
| FSE0750NB | 50*58*5/6 LBH(NBR90)黑膠 | |
| FPUC0016N | 40*60*10 USH (NBR90度) | |
| FSE0232N0 | 40*60*12 USH | NBR90度 |
| FPUC0311N | 45*60*7 USH(NBR90) | 新模 |
| FPUC4560N | 45*60*10 USH(NBR90黑膠) | |
| FSE0225N0 | 45*60*12 USH | NBR90度 |
| FPUC4860N | 48*60*10 USH(NBR90) | |
| FPD85060N | 50*60*5/6.5 LBH(NBR90度) | |
| FPUC5006N | 50*60*6 USH(NBR90黑膠) | |
| FPUC3061N | 30*61*6 USH(NBR90度) | |
| FPD54062N | 40*62*8/11 DKB(NBR90) | NBR90度黑膠 |
| FSF0714N0 | 50*62*7/10 DKB | |
| FPUC5008N | 50*62*8 USH(NBR90度) | |
| FPUC5062N | 50*62*10 USH(NBR90)黑色 | |
| FPUC0003N | 50*63*8 USH(NBR90度) | |
| FPU05363N | 53*63*6 USH | 刻字USH-53 |
| FSF0265N0 | 45*65*12 USH | NBR90度 |
| FPUC4809N | 48*65*9 USH黑膠(NBR90) | |
| FPUC4865N | 48*65*10 USH(NBR90)黑膠 | |
| FPUC5065N | 50*65*10 USH | |
| FPUC0001N | 52*65*9 USH (NBR90度) | |
| FPUC5565N | 55*65*10 USH(NBR90度) | |
| FSF0821NB | 50*68*7/10 DKB | |
| FPUC5068N | 50*68*8 USH(NBR90黑膠) | |
| FPUC5568N | 55*68*8 USH(NBR90)黑膠 | |
| FSF0513NB | 58*68*6 USH(NBR90度) | |
| FPD55569N | 55*69*8/11 DKB | |
| FPUC0010N | 40*70*10 USH (NBR90度) | |
| FPUC0014N | 50*70*10 USH (NBR90度) | |
| FSF0247N0 | 50*70*12 USH | NBR90度 |
| FPUC5570N | 55*70*10 USH NBR90度 | |
| FPUC5870N | 58*70*6 USH NBR90度 | |
| FPD90060N | 60*70*6/8 LBH(NBR90SHORE) | |
| FPUC6070N | 60*70*6 USH NBR90 | SKY-60 |
| FSF0148N0 | 60*70*9 USH(VC軟) | |
| FPD55072N | 50*72*8/11 DKB(NBR90) | 僅刻BR0315E無WLK |
| FSG0550N0 | 60*74*8/11 DKB | |
| FPUC0018N | 60*75*8 USH (NBR90度) | |
| FPUC6075N | 60*75*10 USH(NBR90度) | 深綠色;黑色 |
| FSG0489NB | 65*79*8/11 DKB(NBR90) | |
| FPUC6010N | 60*80*10 USH(UN) | NBR90度深綠色 |
| FPUB0001N | 60*80*12 UPH | UPH-60A |
| FPUC6509N | 65*80*9 USH(NBR90度) | |
| FPUC6580N | 65*80*12 USH NBR90度深綠 | 深綠色無WLK商標 |
| FPD90070N | 70*80*6/8 LBH(NBR90度) | |
| FPUC7006N | 70*80*6 USH | (NBR90深綠色);黑色 |
| FPUC0005N | 71*80*8 USH(NBR90度) | |
| FSH0389NB | 60*82*11/14 DKB(NBR90) | |

| WLK CODE | DESCRIPTION | REMARKS |
|-------------|-------------------------|----------------|
| FPUC7083N | 70*83*8 USH(NBR90黑膠) | |
| FPD57011N | 70*84*8/11 DKB | 僅刻AR3493F不要WLK |
| FPUB0003N | 65*85*10 USH NBR90度 | |
| FPUC0287N | 70*85*9 USH(NBR90)黑膠 | |
| FPD57589N | 75*89*8/11 DKB(NBR90) | 僅刻字AR3596G無WLK |
| FPUB0008N | 70*90*12 UPH(NBR90)黑膠 | |
| FPUC8006N | 80*90*6 USH(NBR90深綠色) | |
| FPD58094N | 80*94*8/11 DKB | 僅刻AR3720I |
| FPUC7595N | 75*95*12 USH(NBR90) | |
| FPD58599N | 85*99*8/11 DKB(NBR90) | 僅刻字AR3828F無WLK |
| FPUC0257N | 80*100*10 USH(NBR90) | NBR90 |
| FPUC0258N | 80*100*12 USH(NBR90) | |
| FPU85100N | 85*100*9 USH(NBR90黑膠) | |
| FPUC8510N | 85*100*10 USH黑膠NBR90 | |
| FPUC85100N | 85*100*12 USH(NBR90黑膠) | |
| FPUB0004N | 88*100*8.5 USH NBR90度 | |
| FPDU0088N | 88*100*21 DUSH(NBR80) | |
| FPD50900N | 90*104*8/11 DKB | |
| FPD59511N | 95*104*8/11 DKB | |
| FPUC90105N | 90*105*9 USH NBR90深綠色 | SKY-90 |
| FPD59510N | 95*109*8/11 DKB | |
| FPUB0006N | 90*110*12 USH | |
| FPU95110N | 95*110*9 USH(NBR90)黑色 | |
| FPUC0154N | 95*110*10 USH(NBR90)黑色 | |
| FPD51001N | 100*114*8/11 DKB | |
| FPUC90115N | 90*115*10 USH(NBR90深綠) | |
| FPUC100120N | 100*120*12 USH(深綠色) | |
| FPUC105120N | 105*120*9 USH NBR90度 | 綠色無WLK商標 |
| FPD51051N | 105*121*9/12 DKB(NBR90) | |
| FPUC100125N | 100*125*12 USH(深綠色) | |
| FPUC105125N | 105*125*10 USH(NBR90深綠) | |
| FPUB0007N | 110*125*9 UPH(NBR90)黑膠 | |
| FSL0159NB | 110*126*8/11 DKB | |
| FPU61181N | 118*133*9 ISI | NBR黑色90 |
| FPD512012N | 120*136*9/12 DKB | |
| FPD51501N | 150*170*10/14 DKB | |
| FPUC180200N | 180*200*12 USH(NOK) | |
| FPD51801N | 180*205*12/17 DKB | |
| FST0021N0 | 185*210*12/17 DKB | |
| FPUB0200U | 200*225*15 UPH(NOK商標) | NOK商標 |
| FPUC0225N | 230*250*12 USH | |
| FPUZ00001N | 260*300*20 USH | |

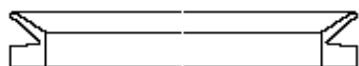

VA = VR1

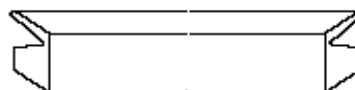

VS = VR2

| WLK CODE | OIL SEALS | SHAFT DIAMETER (RANGE in inch) |
|-----------|-----------------------|--------------------------------|
| FRQ00070N | VA007 V-RING | 0.260" ~ 0.310" |
| FRQ00010N | VA010 V-RING | 0.370" ~ 0.450" |
| FRQ00012N | VA012 (VR1) VRING | 0.450" ~ 0.530" |
| FRQ00014N | VA014 (VR1) VRING | 0.530" ~ 0.610" |
| FRQ00016N | VA016 (VR1) VRING | 0.610" ~ 0.690" |
| FRQ00018N | VA018 (VR1) VRING | 0.690" ~ 0.750" |
| FRQ00020N | VA020 (VR1) VRING | 0.750" ~ 0.830" |
| FRQ00220N | VA022 V-RING | 0.830" ~ 0.950" |
| FRQ00025N | VA025 (VR1) VRING | 0.950" ~ 1.070" |
| FRQ00280N | VA028 V-RING | 1.070" ~ 1.140" |
| FRQ00030N | VA030 (VR1) VRING | 1.140" ~ 1.220" |
| FRQ00030F | VA030 VRING(FKM)VITON | 1.140" ~ 1.220" |
| FRQ00320N | VA032 V-RING | 1.220" ~ 1.300" |
| FRQ00035N | VA035 (VR1) VRING | 1.300" ~ 1.420" |
| FRQ00038N | VA038 (VR1) VRING | 1.420" ~ 1.500" |
| FRQ00040N | VA040 (VR1) VRING | 1.500" ~ 1.700" |
| FRQ00450N | VA045 V-RING | 1.700" ~ 1.890" |
| FRQ00501N | VA050 V-RING | 1.890" ~ 2.090" |
| FRQ00055N | VA055 (VR1) VRING | 2.090" ~ 2.290" |
| FRQ00060N | VA060 (VR1) VRING | 2.290" ~ 2.480" |
| FRQ00065N | VA065 (VR1) VRING | 2.480" ~ 2.680" |
| FRQ00700N | VA070 V-RING | 2.680" ~ 2.880" |
| FRQ00075N | VA075 (VR1) VRING | 2.880" ~ 3.070" |
| FRQ00800N | VA080 V-RING | 3.070" ~ 3.270" |
| FRQ00850N | VA085 V-RING | 3.270" ~ 3.470" |
| FRQ00900N | VA090 V-RING | 3.470" ~ 3.660" |
| FRQ00950N | VA095 V-RING | 3.660" ~ 3.860" |
| FRQ01000N | VA100 V-RING | 3.860" ~ 4.140" |
| FRQ01100N | VA110 V-RING | 4.140" ~ 4.530" |
| FRQ01300N | VA130 V-RING | 4.530" ~ 4.920" |
| FRQ01400N | VA140 V-RING | 4.920" ~ 5.320" |
| FRQ01500N | VA150 V-RING | 5.320" ~ 5.710" |
| FRQ01600N | VA160 V-RING | 5.710" ~ 6.100" |
| FRQ01700N | VA170 V-RING | 6.500" ~ 6.890" |
| FRQ01800N | VA180 V-RING | 6.100" ~ 6.500" |
| FRQ01900N | VA190 V-RING | 6.890" ~ 7.290" |
| FRQ02000N | VA200 V-RING | 7.290" ~ 7.680" |
| FRQ02200N | VA220 V-RING | 7.480" ~ 8.270" |
| FRQ02500N | VA250 V-RING | 8.270" ~ 9.250" |
| FRQ02750N | VA275 V-RING | 9.250" ~ 10.430" |
| FRQ03000N | VA300 V-RING | 11.420" ~ 12.200" |
| FRQ03500N | VA350 V-RING | 13.190" ~ 14.370" |
| FRQ04000N | VA400 V-RING | 10.430" ~ 11.420" |
| FRQ00101N | VS010 V-RING | 15.350" ~ 16.930" |

| WLK CODE | OIL SEALS | SHAFT DIAMETER (RANGE in inch) |
|-----------|---------------------|--------------------------------|
| FRQ00121N | VS012 V-RING | 0.370" ~ 0.450" |
| FRQ00141N | VS014 V-RING | 0.450" ~ 0.530" |
| FRQ00161N | VS016 V-RING | 0.530" ~ 0.610" |
| FRQ00181N | VS018 V-RING | 0.610" ~ 0.690" |
| FRQ00201N | VS020 V-RING | 0.690" ~ 0.770" |
| FRQ00221N | VS022 V-RING | 0.770" ~ 0.830" |
| FRQ01025N | VS025 V-RING | 0.950" ~ 1.070" |
| FRQ00281N | VS028 VRING | 1.070" ~ 1.140" |
| FRQ00301N | VS030 V-RING | 1.140" ~ 1.220" |
| FRQ00321N | VS032 V-RING | 1.220" ~ 1.300" |
| FRQ00351N | VS035 VRING | 1.300" ~ 1.420" |
| FRQ00381N | VS038 V-RING | 1.420" ~ 1.500" |
| FRQ00401N | VS040 VRING | 1.500" ~ 1.700" |
| FRQ00045N | VS045 (VR2) V-RING | 1.700" ~ 1.890" |
| FRQ00500N | VS050 VRING | 1.890" ~ 2.090" |
| FRQ00551N | VS055 VRING | 2.090" ~ 2.290" |
| FRQ00601N | VS060 VRING | 2.290" ~ 2.480" |
| FRQ00651N | VS065 VRING | 2.480" ~ 2.680" |
| FRQ00701N | VS070 VRING | 2.680" ~ 2.880" |
| FRQ00751N | VS075 VRING | 2.880" ~ 3.070" |
| FRQ00801N | VS080 VRING | 3.070" ~ 3.270" |
| FRQ00851N | VS085 VRING | 3.270" ~ 3.470" |
| FRQ00901N | VS090 VRING | 3.470" ~ 3.660" |
| FRQ00951N | VS095 VRING | 3.660" ~ 3.860" |
| FRQ01001N | VS100 V-RING | 3.860" ~ 4.140" |
| FRQ01101N | VS110 V-RING | 4.140" ~ 4.530" |
| FRQ01201N | VS120 V-RING | 4.530" ~ 4.920" |
| FRQ01301N | VS130 V-RING | 4.920" ~ 5.320" |
| FRQ01401N | VS140 V-RING | 5.320" ~ 5.710" |
| FRQ01501N | VS150 V-RING | 5.710" ~ 6.100" |
| FRQ01601N | VS160 V-RING | 6.100" ~ 6.500" |
| FRQ01701N | VS170 V-RING | 6.500" ~ 6.890" |
| FRQ01801N | VS180 V-RING | 6.890" ~ 7.290" |
| FRQ01901N | VS190 V-RING | 7.290" ~ 7.680" |

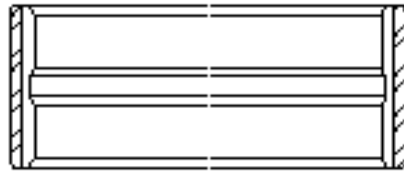

| WLK CODE | DESCRIPTION | REMARKS |
|-----------|-------------------|----------------------|
| FRB00035N | 16*19*8 套 | 久保402合體用 |
| FRB00034N | 15*20*10 套 | |
| FRB00033N | 15*20*11 套 | |
| FRB00032N | 17*21*11.5 套 | 久保402新制成附帶 |
| FRB00031N | 22*27*12 套 | CL-2133 ER65久保 20H 起 |
| FRB00030N | 20*28*11 套 | |
| FRB00025N | 20*28*14 套 | 12501-12571 |
| FRB00036N | 20*30*12.6 套 | |
| FRB00300N | 25*30*11 套 | 2186-738-0360-T |
| FRB00026N | 25*30*14 套 | 井關25馬滾輪 |
| FRB00041N | 25*32*6.5 套 | 久保8馬起動 |
| FRB00027N | 25*35*16 套 | |
| FRB00024N | 25*35*18 套 | |
| FRB00023N | 25*35*22 套 | |
| FRB00350U | 28.6*35*52 BUSH銅管 | |
| FRB00028N | 29*35*27 套 | |
| FRB00040N | 30*35*13 套 | |
| FRB00021N | 30*35*15 套 | 停產 |
| FRB00020N | 30*38*28.5 套 | 久保 17/20H 耕耘軸小套 |
| FRB00019N | 32*38*14 套 | |
| FRB00018N | 30*40*18 套 | 內徑太大 |
| FRB00029N | 30*40*19 套 | |
| FRB00017N | 30*40*21 套 | |
| FRB00016N | 30*40*23.5/25 套 | |
| FRB00015N | 32*40*20 套 | |
| FRB00014N | 35*40*17 套 | |
| FRB00048N | 35*40*36 BUSH | |
| FRB00042N | 32*42*43 套 | 無模 |
| FRB00013N | 35*42*13 套 | |
| FRB00044N | 35*42*16.5 套 | |
| FRB00046N | 37*42*43 套 | |
| FRB00012N | 35*45*17 套 | |
| FRB00049N | 35*45*32 BUSH | |
| FRB00037N | 40*45*13 套 | |
| FRB00047N | 40*45*80 套 | |
| FRB00045N | 45*53*30.5 套 (特材) | (特材) |
| FRB00043N | 45*60*20 套 | |
| FRB00022N | 60*64*25.5 套 | |
| FRB00039N | 75*90*21 套 | |
| FRB00038N | 三菱3250後輪 (86m/m) | 60*86*21 |

Catalogue for Cover



RCA

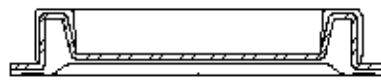

RCA5

| WLK CODE | DESCRIPTION | REMARKS |
|-----------|--------------------------|-------------------|
| FRC00012N | 12*17*11 塞 | |
| FRC00038N | 12*17.5*7 塞 | 三菱660插秧機 |
| FRC00010N | 13*18*8.5 塞(軟塞) | |
| FRC00024N | 15*5 RCA (EZ0016A) | |
| FRC00041N | 16*3 RCA塞 | 外徑16.15~16.25MM |
| FRC00036N | 16.15*3 RCA塞外徑較大 | 5號 |
| FRC00042N | 18*3 RCA | |
| FRC00039N | 18.4*25*10.2塞 | 三菱660插秧機 |
| FRC00040N | 20*40/53*14 Y防震套 | 4083001 |
| FRC00026N | 20*7 RCA(F1620 塞) | F1620 塞 |
| FRC00075N | 21*4 RCA | |
| FRC00037N | 21.5*26.3*6.3 塞(軟) | |
| FRC00061N | 22*5 RCA | |
| FRC00019N | 23*35.5*11/22 RCB2軟 | 17*23/35*22 |
| FRC00009N | 26*32*13 RCA5塞 | 26*32*8/12.7 RCA5 |
| FRC00008N | 27.5*32*6 塞RCA舊模 | 32*6 RCA(無刻字) |
| FRC00007N | 28*34*6 RCA5塞 | L型有鐵殼 |
| FRC00051N | 28*7 RCA | |
| FRC00021N | 28*8/11 RCAY無唇 | |
| FRC00022N | 28/33*5/11 RCA5Y | 有唇 |
| FRC00006N | 30*35*11 塞 | |
| FRC00033N | 30*35*11 塞(舊模) | (舊模) |
| FRC00062N | 30*6 RCA | |
| FRC00063N | 30*7 RCA | |
| FRC00065N | 30*8 RCA | |
| FRC00015N | 30.5 塞 | |
| FRC00005N | 31*35*12 塞 | |
| FRC00030N | 32*45*5/12 塞 | |
| FRC00029N | 32*6 RCA | 力虎塞仔 |
| FRC00066N | 32*7 RCA | |
| FRC00032N | 33.8*40.4*15.4 塞 | |
| FRC00004N | 35*42*10 RCA5 | S280 傳動軸外蓋 |
| FRC00046N | 35*7 RCA | |
| FRC00079N | 35*8 RCA | |
| FRC00031N | 3600 防草蓋 | (83/4/15訂製) |
| FRC00056N | 37*10 RCA | |
| FRC00054N | 37*7 RCA | |
| FRC00020N | 38*10 RCA | 12652-16711 |
| FRC00014N | 39*46*10 塞 | |
| FRC99999N | 39.29*53.57*8.33/23.42RG | RGA塞仔 |
| FRC00025N | 40*7 RCA | |

| WLK CODE | DESCRIPTION | REMARKS |
|------------|------------------|----------------|
| FRC00027N | 42*7 RCA | |
| FRC00023N | 43*10 RCA | |
| FRC00064N | 47*10 RCA | |
| FRC00003N | 47*54*9.5 RCA5塞 | |
| FRC00034N | 47*56*5/18 RCA5Y | 久保SR75割刀曲柄 |
| FRC00053N | 47*7 RCA | |
| FRC00018N | 47*8 RCA | 12501-12251 |
| FRC00011N | 5*14.5*22 塞 | |
| FRC00078N | 50*9 RCA | |
| FRC00049N | 52*10 RCA | |
| FRC00002N | 52*60*8.5 RCA5塞 | |
| FRC00043N | 52*7 RCA | |
| FRC00076N | 55*10 RCA | |
| FRC00052N | 55*7 RCA | |
| FRC00057N | 60*8 RCA | |
| FRC00050N | 62*7 RCA(BLUE) | |
| FRC00001N | 62*72*10 RCA5 | |
| FRC00067N | 62*8 RCA | |
| FRC0006N | 62*9 RCA | |
| FRC00016N | 67 塞 | RC14 |
| FRC00080N | 68*8 RCA | |
| FRC00071N | 72*10 RCA(BLUE) | |
| FRC00055NB | 72*8 RCA | |
| FRC00045N | 72*9 RCA | |
| FRC00081N | 75*7 RCA | |
| FRC00072N | 80*10 RCA(BLUE) | |
| FRC00068N | 80*12 RCA | |
| FRC00058N | 80*8 RCA | |
| FRC00073N | 85*10 RCA(BLUE) | |
| FRC00044N | 90*10 RCA | |
| FRC00059N | 90*8 RCA | |
| FRC00070N | 100*10 RCA(BLUE) | |
| FRC00060N | 100*12 RCA | |
| FRC00074N | 110*10 RCA | |
| FRC00077N | 150*12 RCA | |
| FRC00017N | D39 塞 | |
| FRC00028N | MF185/290前輪防草蓋 | 56.4*101.4*19鐵 |

Catalogue for Complex Seals

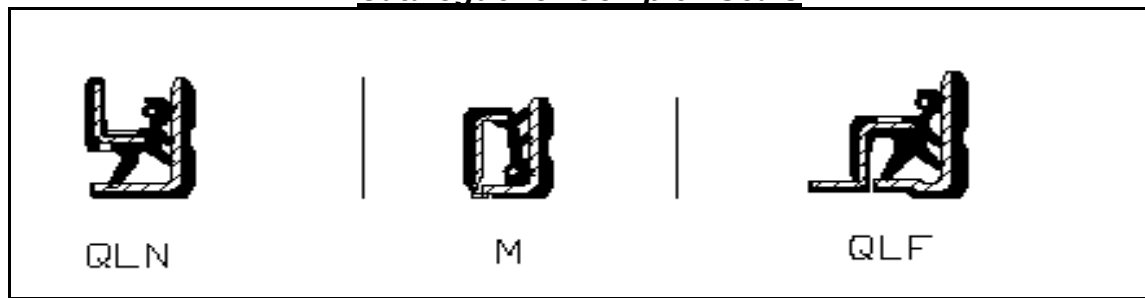

| WLK CODE | DESCRIPTION | REMARKS |
|-----------|-------------------------|------------------------|
| FSAC0001N | 15*35*11 QLN | 三菱尾輪 |
| FSAC0002N | 20*35*5/7 QLN | 久保800播手旋轉軸 迴轉箱 |
| FSAD0001N | 25*40*6/8 QLN | 久保800播手旋轉軸 迴轉箱 |
| FSAD0005N | 20*42*9/12 QLF | 久保PRO601/SR75補助輪 |
| FSAD0010N | 25*44*12/14 合體 | |
| FSAD0008N | 25*46/54*11/12.5 QLFY | BQ4167E(91251-734-003) |
| FSAD0004N | 20*47*12/14 QLF | 大順TS528/628單輪耕耘軸 |
| FSAD0006N | 20*47*12/14 QLF | |
| FSAD0009N | 25*47*10/14 QLN | |
| FSAD0002N | 25*47*12/14.8 QLN | 文豐單輪/耕耘軸及前輪 |
| FSAD0003N | 25*47/54*14 QLF | 野馬1800/2200滾輪軸 |
| FSAE0006N | 30*50*15 M | SUZUE ROTARY |
| FSAE0018N | 25*52*10/16 QLN | |
| FSAE0005N | 25*52*11/18 QLF | MC42滾輪 BQ4096E |
| FSAE0007N | 25*52*16 QLN | 4250滾輪(原裝型)久保43 |
| FSAE0028N | 25*52*8/14.8 QLN | |
| FSAE0010N | 30*52*28 合體 | |
| FSAE0001N | 30*52*9.5/12 QLF | AQ1724日之本1600前擔輪 |
| FSAE0034N | 30*52*9/15 QLN | 展農 |
| FSAE0026N | 32*52/58*12.5/14.5 QLFY | AQ7019E(91205-733-702) |
| FSAE0029N | 35*52*8/18 QLF | |
| FSAE0011N | 25*55*20 合體 | |
| FSAE0002N | 30*55*11.5/19 QLF | YZC ROTARY |
| FSAE0008N | 30*55*8/15 QLN | 文豐雙輪耕耘軸油封 |
| FSAE0032N | 35*55*17/19 QLN | |
| FSAE0004N | 42*55/63*12 TC65(TC65Y) | 久保3001前輪上面 |
| FSAE0027N | 32*58/64*12/14 QLFY | BQ5650E(91206-733-702) |
| FSAE0033N | 35*58*10/17 QLN | |
| FSAE0020N | 35*58*11.4/17 QLN | AQ7745E |
| FSAE0003N | 35*58*9/14 QLN(改) | |
| FSAE0014N | 42*59*14/17.5 合體 | AQ8604P |
| FSAE0031N | 32*60*11/14 合體 | |
| FSAF0002N | 35*60*12/18 QLF | 井關35馬耕耘軸小AQ2110E |
| FSAF0007N | 25*62*10.5/17 QLF | 久保3000/2800滾BQ1577E |
| FSAF0019N | 25*62*11/16 QLN | 久保43(R1-43)滾輪改裝用 |
| FSAF0020N | 28*62*11/17 QLN | 久保R1-43尾輪(無修改)原 |

| WLK CODE | DESCRIPTION | REMARKS |
|-----------|---------------------|-----------------------|
| FSAF0009N | 30*62*11/17 QLN | 6206合體 滾輪 尾輪通用 |
| FSAF0017N | 30*62*12/18 QLF | 大地菱3252/2850車心新型 |
| FSAF0023N | 30*62*13/15.5 QLF | 力虎AQ1754E |
| FSAF0003N | 30*62*16/18 QLN | 井關HA50/60 割稻機滾輪 |
| FSAF0014N | 30*62*8/14.5 QLN | 大順TS700雙輪耕耘軸 |
| FSAF0018N | 30*62/72*21 QLF | 63633-3134-1 |
| FSAF0004N | 35*62*11.5/19 QLN | |
| FSAF0011N | 35*62*13/15.5 QLF | 久保3001前輪下面 |
| FSAF0006N | 35*62*13/18 QLN | AQ8168E(AQ8168P) |
| FSAF0022N | 35*62*13/19 QLF | 力虎SRV4D雙輪輪軸, 文豐 |
| FSAF0008N | 40*62*16 M | 芝浦25Hp前輪 |
| FSAF0043N | 40*62*20 Y(組合) | AZ8603P |
| FSAF0016N | 45*64/73*14.5 QLFY | 4564-7314-6 |
| FSAF0042N | 30*65*10/15.5 QLN | |
| FSAF0013N | 35*65*8/14.5 QLN | 大順TS700雙輪輪軸 |
| FSAF0012N | 38*65*14/17 QLF | AQ7963P, 久3001/4202小 |
| FSAF0001N | 40*65*11/18 QLN | 中農14馬半合體 |
| FSAF0041N | 35*67*17.5 QLN(改) | |
| FSAF0005N | 45*68*11/17 QLN | AQ2671E |
| FSAF0015N | 50*68*12.5 QLFY | AQ8270P, 63681-1717-1 |
| FSAG0001N | 45*70*12/17 QLF | MF2204前輪/日之本41前 |
| FSAG0011N | 48*70*12/17 QLF | AQ8648E, 三菱3250前擔輪 |
| FSAF0034N | 50*70*10/17 QLN | |
| FSAG0015N | 30*72*12/17 QLN | MC5000, 45 六齒車心 |
| FSAG0013N | 30*72*14/16.3 QLF | 久保(割)SR75尾輪 |
| FSAG0016N | 35*72*12/14 QLN(改) | 久保R1-43車心 (內外套皆 |
| FSAG0014N | 35*72*12/22 QLF | 3515159000停產 |
| FSAG0012N | 35*72*20 QLN | 停產 |
| FSAG0036N | 38*72/76*11/16 QLN | BQ3564E代用 |
| FSAF0027N | 40*72*13/16 QLF | AQ8699E (AQ8699P) |
| FSAG0006N | 50*72*12/17 QLN | 久保20H 牛腳新型合體 |
| FSAG0017N | 50*72*9/17 合體 | |
| FSAG0004N | 40*75*14/17 合體 | 芝浦25Hp耕耘軸小 |
| FSAG0009N | 45*75*13/19 QLN | 久保4202前輪帶動下面 |
| FSAG0008N | 45*75*14/17 QLF | 久保4202/7500/5500耕大 |
| FSAG0019N | 50*75*9/17 QLN | 藍地利PTO新型 |
| FSAG0005N | 52*75*15 M | 芝浦25/40馬前輪 |
| FSAG0007N | 60*75*13/26 合體(外套) | YM3000前輪新型站軸 |
| FSAG0020N | 50*76*8/16 QLN | |
| FSAG0002N | 50*76*8/16.5 QLN | MF285耕耘軸大(新型) |
| FSAG0003N | 50*78*10/17 合體 | AQ2881E三菱3250咧 |
| FSAG0025N | 55*78*16 M | 芝浦V52F前輪站軸 |
| FSAH0007N | 40*80*12/18.5 QLN | BQ2999E, 久保2750牛腳 |
| FSAH0011N | 40*80*18.5/20.5 QLF | 野馬1800牛腳 |
| FSAG0035N | 45*80*12/17 QLN | |
| FSAH0004N | 50*80*10/17 QLF | 芝浦40Hp耕耘軸大 |
| FSAH0027N | 50*80*10/17 QLN | 外徑無唇 |
| FSAH0012N | 54*80*13.5/15.8 QLF | AQ3020P |

| WLK CODE | DESCRIPTION | REMARKS |
|-----------|--------------------------|-----------------------|
| FSAH0005N | 55*80*13/18 QLF | 芝浦25Hp耕耘軸大 |
| FSAH0010N | 60*80*13/28 QLN | 野馬43馬前輪/上面 |
| FSAH0026N | 50*82*10/17 QLN | AQ2894E 代用 |
| FSAH0009N | 55*82*10.5/17 QLF | 井關41/久3001大AQ3067E |
| FSAH0020N | 60*82*16 M | |
| FSAH0003N | 60*82*17/19 QLN | MF4050前輪新型 |
| FSAH0029N | 60*84*9/18.5 QLN | BQ3981E |
| FSAH0013N | 45*85*15.5/18.5 QLF | 日之本1500前輪AQ8181P |
| FSAH0006N | 52*85*16/19 QLN | AQ7747E 久保田2202後輪 |
| FSAH0001N | 55*85*13/19 合體 | AQ3074E YM42耕耘軸大 |
| FSAH0002N | 70*89*11/18 QLN | 井關5000/7000前輪 |
| FSAI0015N | 50*90*12/14.5 合體 | AZ7449E |
| FSAI0004N | 50*90*12/21 QLFY | AQ8166P |
| FSAI0005N | 60*90*10/17 QLF | 芝40耕耘軸小AQ8177P |
| FSAI0003N | 60*90*12/18 QLF | AQ7242E, 久7500/5500耕大 |
| FSAH0008N | 65*90*12/18 QLN | 久保田5500/7500前輪 |
| FSAH0019N | 65*90*17 M(NOK) | |
| FSAI0006N | 65*90*17/18 M | 芝浦40Hp後輪 |
| FSAI0001N | 60*92*22 M | 井關9000咧小,松山大 |
| FSAI0002N | 60*95*12/19 QLF | 星牌咧小,野4300小 |
| FSAI0008N | 65*95*11/18 QLF | AQ8943E, 菜園耕耘合體 |
| FSAI0007N | 70*95*12/18 QLNY | AQ8275P, 久4202後輪 |
| FSAI0017N | 75*95*12 QLN | 75*95/103*8/20.5 |
| FSAJ0002N | 60*100*14.5/26 QLF | AQ3250E |
| FSAJ0005N | 65*100*12/19 QLF | 芝浦53馬咧大AQ8673P |
| FSAI0016N | 65*100*17/19 QLN | AQ7984E |
| FSAJ0004N | 68*100*11/18 合體 | 井關5000/6500/7000耕耘軸 |
| FSAJ0017N | 70*100*12/19.5 QLN | AQ7364E代用 |
| FSAJ0007N | 72*100*13/17 QLF | AQ3563E, 野5000耕大 |
| FSAJ0006N | 73*101.6*11.5/18 QLN | MF290/185後輪 |
| FSAJ0016N | 75*105*13/20 QLN | BQ1393E代用 |
| FSAK0002N | 60*110*12.5/21 QLF | 日之本41馬後輪AQ8890P |
| FSAK0001N | 75*110*12/20 QLF | AQ8178P星牌咧大 |
| FSAJ0001N | 75*110*23/25 QLF | 井關9000咧大 |
| FSAJ0010N | 80*110*11/14 QLF | BQ4059E NOK |
| FSAK0003N | 85*110*12/18 QLN | AQ8124P久保5500/7500後輪 |
| FSAK0004N | 76*118*17/20 QLN | 強鹿2140後輪 |
| FSAL0001N | 110*130*15/16 QLN | 飛雅特110馬前輪 |
| FSAN0001N | 90*140*17/20 QLN | 強鹿3140後輪 |
| FSAN0002N | 115*145*12.5/24 QLF | 芝浦5340(53)前輪AQ8251P |
| FSAP0003N | 101.6*152.4*20 QLF | MF 3615 後輪 |
| FSAO0001N | 130*160*15/16 QLN | 三馬61000/71000/81000前 |
| FSAO0001F | 130*160*15/16 QLN(VITON) | |
| FSP0040NB | 136.8*165*13 M(合體) | JOHN DEERE 強鹿用 |
| FSAQ0002N | 145*170*17/21.5合體 | MF194/265前輪 |
| FSAS0003N | 165*190*15/21 QLN | MF3065前輪, 強鹿3140前輪 |
| FSAT0001N | 170*205*25/28 QLN | MF265後輪舊型/MF174後輪 |
| FSAV0001N | 189*220*15/26 QLN | MF194後輪新型 |

| WLK CODE | DESCRIPTION | REMARKS |
|-----------|------------------------|------------------------|
| FSAZ2401A | 240*270*19.5/21.5 QLFY | 2.1529.140.0/75 |
| FSAF0025N | AE6831E NOK | 40*62/72*14 QLN |
| FSAO0003N | AE8601P NOK | 57*92*15 TCY |
| FSAO0002N | AE8876P NOK | 90*160*17/22. |
| FSAE0016N | AQ1724E NOK | 30*52*10.5/12 QLN |
| FSAF0030N | AQ2671E NOK | 45*68*11/17.5 QLN |
| FSAG0023N | AQ2688E NOK | 45*72*13.5/20 QLF |
| FSAG0026N | AQ2693F NOK日本製 | 45*75*14/17 QLF |
| FSAG0024N | AQ2881E NOK | 50*78*10.5/16.5 QLF |
| FSAH0025N | AQ2890E NOK | 50*80*10/17 |
| FSAH0023N | AQ2894E NOK | 50*82*12/25 QLN |
| FSAH0016N | AQ3067E NOK | 55*82*11/17 QLF |
| FSAH0018N | AQ3074E NOK | 55X85X11.5/19 QLF |
| FSAI0013N | AQ3563E NOK | 72X100/115X13/17 QLF |
| FSAH0014N | AQ7242E NOK | 60*90/95*11.5/18.5 QLF |
| FSAI0009N | AQ7364E NOK | 70X100X13.5/19.5 QLF |
| FSAG0022N | AQ7444E NOK | 40*80/93*14/20 QLF |
| FSAE0015N | AQ7546P NOK | 32*55*13.5/16.5 QLN |
| FSAH0024N | AQ7576P NOK | 50*85*12/19.5 QLN |
| FSAF0029N | AQ7963P NOK | 38X65X10.5/16.5 QLF |
| FSAH0022N | AQ7977P NOK | 60*82*17/22 合體 |
| FSAI0010N | AQ7984P NOK | 65*100*17/19 QLF |
| FSAH0015N | AQ8177P NOK | 60*90/96*10/17 QLF |
| FSAJ0008N | AQ8178P NOK | 75X110/125X12.5/20 QLF |
| FSAI0011N | AQ8943E NOK | 65X95X12/18.5 QLF |
| FSAG0021N | AZ8839P NOK | 45*72/83.6*24 |
| FSAG0028N | BQ1475E NOK | 45*70*8.5/20 QLN |
| FSAE0030N | BQ1508E NOK | 50*68*9/14.5合體 |
| FSAF0031N | BQ1601E NOK | 45*63*9/16.5 QLN |
| FSAG0018N | BQ2713E NOK | 35*72*11/19 QLF |
| FSAI0012N | BQ2808E NOK | 70*100/108*14/20.7 QLF |
| FSAF0028N | BQ2811E NOK | 40*70*11/20 QLF |
| FSAH0017N | BQ3138E NOK | 55*88*11/20 QLFY |
| FSAI0018N | 58*90*16/19 QLN(NOK) | BQ3203E |
| FSAH0028N | 58*90*17/19 QLF(NOK) | BQ2215E |
| FSAI0014N | 70*95*17 M(NOK) | 芝浦5345(53馬)後輪輪軸 |
| FSAJ0018N | 92*112*8.5 Y(NOK)合體 | BQ4732E |
| FSAL0002N | 100*125*17 M (NOK) | 芝浦SE5340(53HP)前輪,前 |
| FSAS0002N | MF220-4前輪有珠式 | MF220-4前輪有珠式 |
| FSAF0010N | 久保601浮動式油封(滾輪) | 46*66*20HDDF浮動式油封 |
| FSAF0021N | 中農14馬半輪下 合體 | 外徑有唇不能用 |
| FSBG0236N | 井關HJ682滾輪浮動式油封 | 50*72*18 HDDF 浮動式油封 |
| FSAQ0001N | 日之本28馬前輪有珠式 | 日之本28馬前輪有珠式 |
| FSAS0001N | 日之本522/322前輪有珠式 | 內徑 166mm 外徑 190 mm |
| FSAS0004N | 日之本522/322前輪無珠式 | |

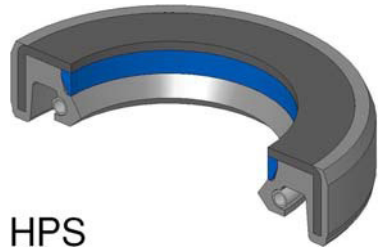

HPS

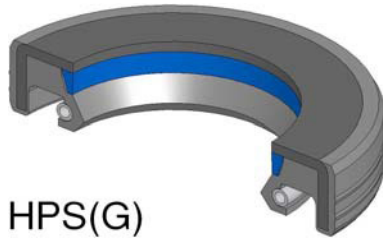

HPS(G)

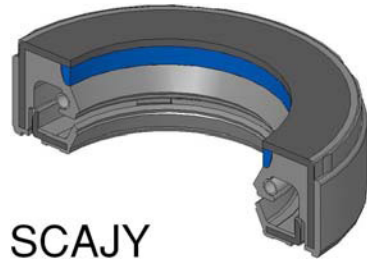

SCAJY



SCJY



SGJY

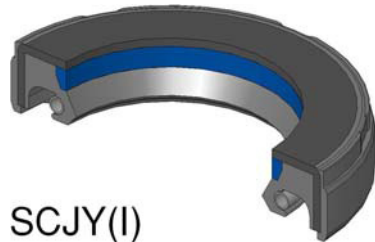

SCJY(I)



TC4Y

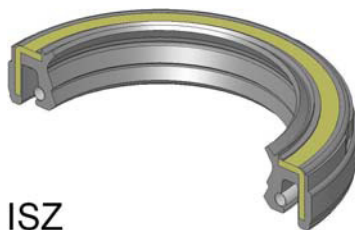

ISZ

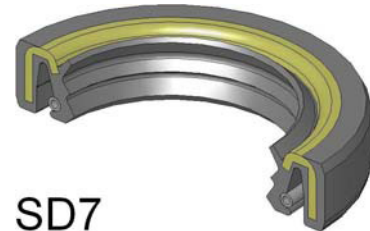

SD7

| WLK CODE | DESCRIPTION | REMARKS |
|-----------|------------------------------|----------------------|
| FSB1051NB | 12*21*7/8 TC4Y(NBR70) | |
| FSB0657NB | 15*21*5/6 TC4Y(NBR90)黑 | |
| FSB1050NB | 12*22*7/8 TC4Y(NBR70度) | |
| FSB0997NB | 16*28*7 SC4 | AR0685G |
| FSB0663NB | 19*29*5/6 ISZ(NBR90) | |
| FSB0662NB | 19*29*7.7/9 ISZ(NBR90) | BP6152E W/O WLK |
| FSB0573NB | 18.5*30*5/5.7 ISZ(TC4Y) | 19*30*5 ISZ NBR90 |
| FSB1075NB | 22*30*5/5.5 ISZ(NBR90) | |
| FSC0703NB | 19*31*5/6 TC4Y(NBR90) | |
| FSC0747NB | 17*32*7/8 TC4Y(NBR90) | |
| FSC0514NB | 19*32*6.5/7 ISZ(NBR90) | 90311-19010 |
| FSC0492NB | 19*32*7/8 TC4Y(TCY) | 90311-19002,NJ913 |
| FSC0667NB | 22*32*5/6 TC4Y(NBR90) | |
| FPF40039N | 22*32*7 SCJY | 49297-34A00 NBR75-80 |
| FSC0672NB | 22*32.5*5/5.5 ISZ(TC4Y) | NBR90 |
| FSC9990NB | 18*32.69*3.4/8.7 TC4Y | for Suzuki(NBR90度) |
| FSC0645NB | 23*34*6.5 SC4(SCJY)NBR90 | 90310-23005 |
| FPF40010N | 24*34*7 SCJY | |
| FSC0666NB | 25*34*6/6.4 TC4Y(NBR90) | BP4082E |
| FSC0662NB | 20.65*34.14*7/7.7 TC4Y NBR80 | BP6049E |
| FPF40072N | 22*34.5*6.5 SJY | |
| FPF40073N | 23*34.5/40.5*7.5 SCJY | |
| FSC9983NB | 20.5*34.7*7/9 TC4Y(NBR90) | BP6049E |
| FPF40001N | 20*35*8 SCJY | power steering |

| WLK CODE | DESCRIPTION | REMARKS |
|-----------|--------------------------|--------------------------|
| PPF40003N | 22*35*8.5 SCJY | 780-2206 |
| PPF40006N | 23*35*6.5/7 ISZ(SCJY) | ISZ型 |
| PPF40052N | 24*35*8.5 SCJY | |
| FSC0541NB | 25*35*5/6 ISZ(NBR90度) | 90310-25032 |
| FSC0668NB | 25*35*7/8 TC4Y(NBR90) | |
| PPF40021N | 25*35*8 SCJY | |
| FSC0951NB | 25*35*9/10 TC4Y(NBR90) | |
| FSC0748NB | 20*36*7/8 TC4Y(NBR85) | |
| PPF40004N | 22*36*7 SCJY(HPS) | Power Steering |
| FSC0670NB | 22*36*7/8 TC4Y(NBR85) | |
| PPF40030N | 24*36*7 SCJY(NBR75-80) | AP8097G |
| FSC0535NB | 24*36*7/7.5 TC4Y | 90029-21010 |
| FSC0552NB | 25*36*5/5.5 ISZ(NBR90度) | |
| PPF40040N | 24*36.2*8 SCJY | |
| FSC0924NB | 22*36.5*6.5 ISZ(NBR90) | |
| PPF40011N | 24*36.5*8.5 SCJY | NBR75-80 |
| PPF40007N | 23*37*9 SCJY(SGJY) | 23.83*36.91*8.74 |
| PPF40053N | 24*37*8.5 SCJY | |
| FSC0659NB | 26*37*7/8 TC4Y NBR90 | |
| PPF40022N | 25*37.5*7 SCJY | BP3524E |
| PPF40046N | 25*37.5/41.5*3/7.5 SCJ5Y | NISSAN SENTRA USED |
| FSC0761NB | 25.4*37.5*7 SCJY | |
| FSC0717NB | 19*38*7/7.5 TC4Y NBR90 | 90311-19007 |
| FSC0693NB | 19*38*7/8 TF | 與19*38*7/7.5 TC4Y相同 |
| PPF40031N | 22*38*8 SCJY(NBR75-80) | AP1133G |
| FSC0767NB | 23*38*6.8/7 SC4(NBR90) | |
| PPF40054N | 23*38*8 SCJY | |
| PPF40042N | 23*38*9 SCJY | |
| FSC0439NB | 25*38*7.5 SD7(TC4) | 48137-Z9005; NP85 |
| FSC0661NB | 25*38*7/7.8 TC4Y NBR90 | 90310-25004 |
| PPF40055N | 25*38*8.5 SCJY | |
| FSC0643NB | 26*38*7/8 TC4Y(NBR90) | |
| PPF40044N | 26*38*8.5 SCJY | chev dimax dir hidra;dir |
| PPF40070N | 27.7*38*8.5 SCJY | |
| FSC0741NB | 28*38*7 SC4(NBR90) | |
| FSC9998NB | 27.79*38.1*7.14 SD7 | |
| PPF40012N | 24*38.2*8.5 SCJY | NBR75-80 |
| PPF40074N | 25*38.2*7.2 SCJY | |
| PPF40005N | 22*38.5*8 SCJY | |
| PPF40023N | 25*38.5*8.5 SCJY(SGJY) | |
| PPF40043N | 24*39*8.5 SCJY | |
| PPF40024N | 25.5*39*8.5 SCJY | |
| PPF40056N | 25*39.5*10.5/13 SCJY | |
| FSC0282NB | 28*39.9*4.2/6.5 SCJY | W/TEFLON RING shaft 27.5 |
| PPF40002N | 20*40*7 SCJY(HPS) | power steering |
| PPF40008N | 23*40*9 SCJY | 刻BP4048E |
| PPF40013N | 24*40*7 SCJY (HPS) | NBR 75-80 |
| PPF40014N | 24*40*8.5 SCJY(HPS) | NBR 75-80 |
| FSC0945NB | 27.5*40*4/6 SCJY | |
| PPF40057N | 28*40*4/6 SCJY | |
| FSC0931NB | 28*40*6/7 ISZ(NBR90) | |
| PPF40058N | 28*40*8 SCJY | |

| WLK CODE | DESCRIPTION | REMARKS |
|-----------|-------------------------|--------------------|
| FSC0725NB | 30*40*6.5/7 TC4Y(NBR90) | |
| FPF40059N | 30*40*8 SCJY | |
| FSC0746NB | 32*40*7/8 TC4Y(NBR90) | |
| FSD0944NB | 23*41*9 SCJY | |
| FPF40015N | 24*41*8.5 SCJY(SGJY) | 90310-24012 |
| FPF40071N | 25.5*41*8.5 SCJY | |
| FPF40060N | 26*41*12.5 SCAJY | |
| FPF40026N | 27*41*8.5 SCJY | |
| FPF40047N | 28*41*8 SCJY | |
| FPF40018N | 25.5*41.1*8 SCJY | |
| FPF40009N | 23*41.2*8 SCJY | |
| FSD0945NB | 27*41.2*8.5 SCJY | |
| FPF40016N | 24*42*8.5 SCJY | 780-24030;NBR75-80 |
| FPF40032N | 27*42*8.5 SCJY | NBR75-80 |
| FPF40029N | 27*42*9/10 TCJY | NBR75-80 |
| FPF40062N | 27.7*42*8.5 SCJY | |
| FPF40063N | 27.7*42*9/10 SCJY | |
| FSD0675NB | 30*42*7/8 ISZ NBR90 | 90311-30016 |
| FPF40061N | 30*42*8 SCJY | |
| FPF40019N | 25.5*42.5*8 SCJY | 90310-25017 |
| FPF40028N | 30*42.5*8 SCJY(SGJY) | BP5420E |
| FSD9921NB | 32.54*42.88*6.65 SC4 | NBR80 |
| FPF40017N | 24*43*7 SCJY | |
| FPF40051N | 24*43*7.5 SCJY(75~80度) | |
| FSF40042N | 25*43*8 HPS NBR75-80 | 23711-01909-000 |
| FPF40037N | 25*43*9 SCJY | NBR75-80 |
| FPF0068N | 26*43*12.5 SCAJY | |
| FPF40036N | 26*43*8.5 SCJY(HPS) | |
| FPF40027N | 27*43*8.5 SCJY | |
| FSD0924NB | 28*43*8 SD7 | |
| FPF40069N | 31*43*7 SCJY4 | |
| FPF40020N | 25.5*44*8.5 SCJY | |
| FPF40041N | 26*44*8 HPS (SCJY) | 90310-26018 |
| FPF40050N | 26*44*8.5 SCJY(I) | (NBR75-80) |
| FPF40048N | 27*44*8 SCJY | |
| FSD0941NB | 27*44*8.5 SCJY | |
| FPF40035N | 28*44.5*8.9 SCJY | |
| FSD0230NB | 28*44.5*9.5 SCJY | W/TEFLON RING |
| FPF40034N | 28*44.7*9 SCJY | |
| FPF40033N | 25*45*8 SCJY | |
| FSD0714NB | 26*45*8.5 SCJY | |
| FPF40025N | 26*45.2*7 SCJY | AP1476E |
| FSD0565NB | 27*46*13 SCAY | |
| FPF40064N | 27*46*8 SCJY | |
| FSD0946NB | 28*46*8.5 SCJY | |
| FSD0610NB | 30*46*8 SGJY(SCJY) | 90310-2A820 |
| FPF40065N | 32*46*8.5 SCJY | |
| FPF40049N | 30*46.2*8 SCJY | |
| FSD0868NB | 30*47*7 SCJY(SGJY) | |
| FPF40066N | 30*47*9 SCJY | |
| FSD0780NB | 30*48*8 HPS(G) | |
| FSD0739NB | 30*48*8 SGJY | 90310-30012 |

| WLK CODE | DESCRIPTION | REMARKS |
|-----------|------------------------|----------|
| FSD0684NB | 31.75*48*8/9 TC4Y(TCL) | NOK日本製 |
| FSD0210NB | 30*50*8.5 HPS(SCJY) | |
| FPF40038N | 32*50*8.5 HPS(SCJY) | NBR75-80 |
| FSD0737NB | 35*50*8 SCJY(NBR75-80) | |
| FPF40067N | 38*51*8.5 SCJY | |
| FSE0685NB | 35*55*8/9 TC4Y(NBR90) | |
| FPF40045N | 35*56*8 HPS(G) SCJY | NBR75-80 |

Catalogue for Spark Plug Holder Used Seals

| OIL SEALS | Reference | drawing |
|---------------------------|---------------------------|---|
| 25*48*10/11 SCY(Brown) | TOYOTA 1.6-93 4AF |  SCYI |
| 25.81*45.24*10.72 SCY | CEFIRO V6 24V | |
| 26*48*10 SCY (Brown) | 11193-15010 | |
| 27*44*7.5/10.5SCYI | Hyundai Accent Plus Seals | |
| 27*49*10/11 SCY(Brown) | NISSAN SENTRA 331 91-96 | |
| 27*49*7.5 SC | 13276-53Y10, MARCH 1.3 |  SCY |
| 23.83*31.34/41.28*16.66Y | MD339118 |  Y3 |
| 25.81*34.92/42.47*16.2 Y3 | MD-162076/198128 | |
| 24*40*7.3/9.5 VCY | CIVIC K800 96-01 |  VCY |
| 23.5*40.5*6.7 Y(軟) | 12342-PM6-000 |  Y1 |
| 25*36.5*6 Y(軟) | 12342-PR3-000 |  Y2 |
| 24.61*40.5/48.5*3.2/9 Y | NISSAN PLUS SEALS |  |

Catalogue for Spark Plug Holder Used Seals

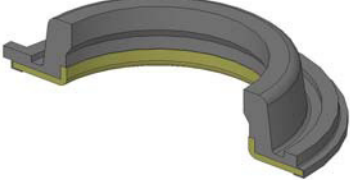
| OIL SEALS | Reference | drawing |
|----------------------|-------------------------|---|
| 28.6*48.5*3.1/10.8 Y | TOYOTA CORONA 2.0 3S-FE |  |

Catalogue for others

| WLK CODE | DESCRIPTION | REMARKS |
|------------|---------------------------|--------------------|
| FOC00016N | 1.6MM油環條 | O-RING CORD |
| FOC00262N | 2.62MM油環條 | O-RING CORD |
| FOC00020N | 2MM油環條 | O-RING CORD |
| FOC00353N | 3.53MM油環條 | O-RING CORD |
| FOC00350N | 3.5MM油環條 | O-RING CORD |
| FOC00030N | 3MM油環條 | O-RING CORD |
| FOC00450N | 4.5MM 油環條 | O-RING CORD |
| FOC00040N | 4MM油環條 | O-RING CORD |
| FOC00550N | 5.5MM 油環條 | O-RING CORD |
| FOC00050N | 5MM油環條 | O-RING CORD |
| FOC00060N | 6MM油環條 | O-RING CORD |
| FOC00070N | 7MM油環條 | O-RING CORD |
| FOC00080N | 8MM油環條 | O-RING CORD |
| FOC00090N | 9MM油環條 | O-RING CORD |
| FOC00100N | 10MM油環條 | O-RING CORD |
| FOC00110N | 11MM油環條 | O-RING CORD |
| FOC00120N | 12MM油環條 | O-RING CORD |
| FOC00150N | 15MM油環條 | O-RING CORD |
| FOC00030E2 | 3MMSponge Cord發泡實條 | EPA Foam |
| FRW00060N | 6MM封閉墊圈 | 6*13.5*2 WF |
| FRW00080N | 8MM封閉墊圈 | 8*18.2*2 WF |
| FRW00100N | 10MM封閉墊圈 | 10*18.5*2 WF |
| FRW00102N | 10.2MM封閉墊圈 | 10.2*18*1.5/2.3 WF |
| FRW00120N | 12MM封閉墊圈 | 12*22*2 WF |
| FRW00145N | 14.5MM封閉墊圈 | 14.5*22*2 WF |
| FRW00140N | 14MM封閉墊圈 | 14*22*2 WF |
| FRW00160N | 16MM封閉墊圈 | 16*22.5*2 WF |
| FRW00112N | 92*112*1.5/2 墊片 | FP40 |
| FRW00130N | 110*130*1.5/2 墊片 | FP50 |
| FRT00018F | 100.4*2.64 VITON | 98386419綠色墊片 |
| FRG00119N | 119*129.4*2.9 Square Ring | Square Ring墊片 |
| PMB0013S | 15.56*20.25*0.5白鐵華司 | 白鐵華司鐵片 SUS304 |
| FRQ00003N | 150*12*3/25 CPH軟 | |
| FRH0001N | 16.51*28.58*9.01白鐵圈+ | |
| FRT00015N | 17*50*2 方型環(NR) | 96293511模具修改 |
| PM00007C | 17.2*44.5*6-1.5T鐵殼 | 電度五彩 |
| FRT00017E | 17.5*46.5*16 RING(EPDM85) | J10180 |
| FRT00013N | 17.8*50*2 方型環(NR) | 96293511 |
| FRW00186N | 18.6*30.55*2.3 WF | CR73893 |
| FRG00194N | 19.4*27.5*5.9 RING(NBR90) | |
| FRT00009N | 2.047*2.047*0.700 軟 | G002 |
| PMC0195C | 20*32*6 CAPS藍色1 | 鐵殼 |
| PME0001C | 20*59.2*5.8 鐵殼 | |
| PM00013C | 20.5*60.5*12.5-T1.5鐵蓋 | 單輪耕 |
| FRW02100F | 200*210*1.6 方形墊片(FKM) | VITON黑色 |
| PM00014C | 25*65*12.5-T1.5鐵蓋 | 單輪下 |

| WLK CODE | DESCRIPTION | REMARKS |
|-----------|--------------------------|--------------------------|
| FRW00010N | 25.4*49.20*3.18 WF華司 | 1.000*1.937*0.125 華司 |
| FRQ00007N | 27*35*2 Rubber Flat Wash | Rubber Flat Washer NBR70 |
| FRW00001N | 27*37*0.75/1.75 Y | 進取專用(無商標) |
| FRG00005 | 2833 Gear Seal O-RING | |
| FRG00006 | 2917 Edger Gear O-RING | Edger Gear Seal Mold |
| FRT00016N | 30*38*53Boot w/PHX-9908 | W/PHX-9908 engraves |
| PMD00068C | 30*42*4.5 CAPS藍色1 | 鐵殼 |
| FPU41221N | 33001-22351軟 | |
| FPU71223N | 33302-0011.1軟 | |
| PMG0001C | 35.2*71.8-4.0T 華司 | |
| PMH0001C | 35.2*88*9-2.0T 鐵殼 | |
| FRG00013B | 4*38*1.95 Y(HNBR材質) | 瓦斯彈片橡膠 |
| FRG00013N | 4*38*1.95 Y(NBR材質) | 瓦斯彈片橡膠 |
| PM00012C | 40*58.25*7 鐵殼+灰羊毛 | T1222 W/Gray Felt |
| FRG00042N | 42*100*30 墊片 | GF-880416 |
| FRG00003N | 43204-60020FELT&RUBBER | 毛氈橡膠墊片 |
| FRG00006N | 43204-60030 FELT&RUBBER | 毛氈橡膠墊片 |
| FRG00005N | 43204-60050FELT&RUBBER | 毛氈橡膠墊片 |
| FPY10001T | 47.8/48/50*63/65.7*12.8 | KTB95279 |
| FRQ00004N | 50*12*3/25 CPH | |
| FRT00014N | 54*83/83*3 Gasket四方型 | 96293578 |
| PM00008C | 6.2*32*12 鐵殼 | 內孔32*板厚1.5 |
| PM00016C | 7.95*12.8*3.58 鐵殼PLUG | CUP PLUG R13041不要中孔 |
| FRG00070N | 70*163*12.5 墊片 | GF-880411 |
| PM00009C | 73.5*75.2/77*6 L型鐵殼 | 鐵殼鍍五彩 |
| PM00004C | 79.5*91*4.8/9.7 RING | 04422-20010(鐵殼鍍五彩) |
| PM00011C | 79.5*91.5/93.5*5.5/10.7 | T1166+1263+122鐵殼鍍五彩 |
| PM00010C | 79.5*92/93.5*12/16.5鐵殼 | 鐵殼鍍五彩 |
| FRQ00002N | 8*12.5/19*9.3 線套 NBR55 | MCKGGR00 |
| PM0012111 | 8*15.5*5.9 金屬環 | 11.5*14.5*5.1 金屬環 |
| PM00003C | 80*91.7*5.5/10.5 RING | 04422-12020(鐵殼鍍五彩) |
| FRD10002B | 9*12.2*3.5(CR65)避震氣室 | 得隆專用 |
| PM00015C | 9*141.70*75割草機防護鐵 | 割草機防護鐵蓋 |
| PMA0001P | 9.65*12.8*0.5 Washer銅片 | Washer Bronze銅華司 |
| FRQ00005N | 9.93*14.33*1.40 墊圈 | |
| FRG00983N | 98.3*101*2.7Square Ring | D4NN G962B |
| FRT00005N | ATE 3.3590-0700.1黑色 | RUBBER DUST CAP黑色 |
| FRH0372N | B372 (GT80) | 22.5*29*17.5 |
| FRH0374N | B373 (GT81) | 29*37.5*17.5 |
| FRE00090 | Belt 90XL037 Brando | 同步齒型帶ECKG0070 |
| FRE00901 | Belt 90XLX6.35mm | Trans. Brand同步齒型帶 |
| FRG00015N | buttom molding charge sh | share 10*10mm |
| FRG00002N | C204 電熱皮墊 | |
| FSD0091N0 | D.480 黑色軟 | |
| FSD0424N0 | D.481 灰色軟(開新模) | 33.58*39.9/46.6*10.9 |
| FSG0001N0 | D792 | 2.543X2.996X0.430 |
| FRG00007N | F-30背蓋防水墊圈 | |
| FRG00008N | F-30機殼防水墊圈 | |
| FRT00006N | G762 SBR70 絕緣 | |
| FRT00007N | G766 SBR70 絕緣 | |
| FRD10001N | Isolation Mount(防震座) | XCMU0033 |

| WLK CODE | DESCRIPTION | REMARKS |
|-----------|-------------------------|--------------------------|
| FRT00003N | L型長 軟 | 15*23/29*19.5 |
| FRT00004N | L型短 軟 | 15*21/26.7*8.3 |
| PM00005C | MCKGHO01 (白鐵) | 水管夾12.7m寬帶*44m#410 |
| FRG00014N | NBR NB0426LT橡膠測試扣 | |
| FSD0550NB | PAT NO 851246 | S58 530 329D |
| FRT00001N | PL11 14.51*63.5*45 | MF290/185剎車油封 |
| FRT00008N | PL11鐵殼灰色處理 | C5NN 2N336A外銷用 |
| FRG000070 | RCMU0103 | 墊片 石棉0.8mm棕色 |
| FRQ00001N | RUBBER BAND (橡膠圈) | |
| FRQ00008N | Rubber Sample No.6NBR90 | NBR90度 |
| FRT00010N | S1468(D987)軟SBR70-75度 | 0.630*1.540*0.500 |
| FRT00011N | S1492 軟 | |
| FRT00012N | S1492A軟(SBR 50-55度) | 0.827*1.535*0.394 |
| FRG00016Q | SP2 CASE BACK矽利康 | VMQ70度 |
| FRG00001N | 三菱插秧機緩衝橡皮 22-2 | 三菱插秧機緩衝橡皮 22-2 |
| PM00001C | 久保(割)SR75尾輪鐵蓋 | 30.3/15.2*85.9*11.8-T1.8 |
| PM00002C | 久保田PRO601尾輪鐵蓋 | 25*75*12-T2.0 |
| FRP00001N | 水箱蓋 (日製) | |
| FRP00002N | 水箱蓋 (臺製) | |
| FSC00032N | 防草蓋 | (83/8/15訂製) |
| FLS00200 | 座椅三角型 | 三輪車座椅 |
| FLS00100 | 座椅豪華型 | 豪華座椅 |
| FRT00002N | 野馬1800脫谷管 | |
| FLN00002 | 野馬4/6種分離針(鐵板型) | |
| FLG00001 | 野馬4種推苗桿 | |
| FLN00001 | 野馬6/7種分離針左右全組 | |
| FRZ00001N | 野馬6種導板左右全組 | |
| FRZ00002N | 野馬6種導板新型左右全組 | |
| FEG00001 | 野馬推板 | |
| FLS00210 | 彈簧5.0及華司螺母(三輪椅) | 三輪車座椅用 |
| FSB0516N0 | 0.328 Valve Cover | 0.328*0.828*0.516軟 |

USO AUTOMOTRIZ



TU PROVEEDOR ESTÉS DONDE ESTÉS

WLK PRODUCTS VS OEM NO.

DATE : 2014/01/03

| CAR | MODEL | APPLICATION | OEM NO. | SIZE | DATA acc. | CODE | YEARS |
|--------|--|--------------------------------|----------------------|---------------|-----------|--------|--------------|
| TOYOTA | 20R 4 cyl (ohc) 2189 cc | Timing Cover | 90311-45094 | 45*68*12 | PAYEN | NJ243 | 8/74-on |
| TOYOTA | 6R 4 cyl (ohc) 1808 cc | Crank Shaft Rear | 9031180001/02 | 80*100*12 | PAYEN | NJ 030 | |
| TOYOTA | ARISTO----- JZS,UZS | Power Steering Rack Housing | | 30*42*7/8 | MUSASHI | T1289 | |
| TOYOTA | Caldina-2C...CT19# | Engine Oil Pump | | 22*34*6.5 | MUSASHI | T1269 | '92.11~ |
| TOYOTA | Camry | Transmission | 90311-38005 | 38*58*18.3 | MUSASHI | | |
| TOYOTA | Camry TA TA57C | Transmiss | 90311-38042 | 38*58*11 | PAYEN | NJ 609 | |
| TOYOTA | Camry(FWD) | Engine Crank Shaft Rear | 90311-89001 | 89*105*10 | MUSASHI | | '90.7~'92 |
| TOYOTA | Camry(FWD) | Engine Crank Shaft Rear | | 92*110*10 | MUSASHI | | '87.4~'94 |
| TOYOTA | Camry(FWD)- SV,CV,CZC | Engine Crank Shaft Front | 90311-12003 | 42*60*7 | MUSASHI | T1178 | '82.2~'81.8 |
| TOYOTA | Camry(R.W.D.)- TA,RA | Steering Worm | 90311-19001 | 19*32*8 | MUSASHI | T1019 | '78.8~'88.9 |
| TOYOTA | Camry(RWD)- TA4#,57C,RA55C | Steering Worm Gear | 90311-19001 | 19*32*7 | MUSASHI | T1019 | '80.1~'82 |
| TOYOTA | Camry.VISTA(F.W. D.)-SV,CV,VZV | Cam Shaft | 90043-11229 | 38*50*8 | MUSASHI | T1192 | '82.3~'88.5 |
| TOYOTA | Camry.VISTA(F.W. D.)-SV,CV,VZV | Crank Shaft Rear | 90311-85004 | 85*105*10 | MUSASHI | T1183 | '84.2~'89.3 |
| TOYOTA | Camry.VISTA(F.W. D.)-SV,CV,VZV | Crank Shaft Rear | 90311-85003 | 85*105*10 | MUSASHI | T1183 | '84.2~'89.3 |
| TOYOTA | Carina TA | Steering sector | 90310-28014/27 | 28*40*8 | PAYEN | NJ 591 | |
| TOYOTA | Carina TA TA63...GRR | Differential pinion | 90311-38003/10/28 | 38*74*11.5 | PAYEN | NJ 002 | |
| TOYOTA | Carina(F.W.D.)AT,S T,CT,ET | Cam Shaft | 90311-35006 | 35*49*6 | MUSASHI | T1173 | '88.8~ |
| TOYOTA | Carina(F.W.D.)AT,S T,CT,ET | Crank Shaft Rear | 90311-90002 | 90*110*8.5/10 | MUSASHI | T1212 | '82.10~ |
| TOYOTA | Carina(R.W.D.)- TA,RA,AA,SA,CA,K | Transmission Front | 9031130015 | 30*45*8 | MUSASHI | T1050 | '74.1~'85.7 |
| TOYOTA | Carina(R.W.D.)- TA,RA,AA,SA,CA,K | Transmission Front | 90311-32060 | 32*48*8 | MUSASHI | T1054 | '70.12~'72.7 |
| TOYOTA | Celica(R.W.D) | Differential Side | 90311-35018 | 35*63*10/16.5 | MUSASHI | | '85.10~'88 |
| TOYOTA | Celica(R.W.D.)- TA,RA,MA,AA,SA,G | Transmission Rear | 90311-32066 | 32*52*11 | MUSASHI | T1052 | '70.12~'81.9 |
| TOYOTA | Celica(RWD) | Engine Timing Gear Cover | 04422-10010 | 48*70*12 | MUSASHI | T1233 | '81.7~'85.12 |
| TOYOTA | Celica(RWD)- TA,RA,SA,AA,GA,M | Trnsmission Lever Shaft | 90311-11128 | 11*22*7 | MUSASHI | T1259 | |
| TOYOTA | Celica(RWD) TA63,SA60,GA61,M A6# | Transmission Front Oil Pump | | 38*55*8.5 | MUSASHI | T1256 | '77.8~'81.6 |
| TOYOTA | Century | Front Wheel | 90311-62147 | 62*85*8/10 | MUSASHI | | |
| TOYOTA | Century | Rear Shaft | 90310-50032 | 50*70*9 | MUSASHI | | |
| TOYOTA | Century | Rear Wheel | 90313-48002 | 48*62*9/24 | MUSASHI | | |
| TOYOTA | Century | Steering Worm | 90310-42014 | 42*60*9 | MUSASHI | | |
| TOYOTA | Century | Timing Cover | 90311-45047 | 45*68*12 | MUSASHI | | |
| TOYOTA | Charmant | Transmission | 90311-25001-000 | 25*38*7 | MUSASHI | | |
| TOYOTA | Coaster | Crank Shaft | 90311-60068 | 80*100*12 | MUSASHI | | |
| TOYOTA | Coaster | | 90311-78001, AA3695E | 78*115*14/20 | NOK | | |

| CAR | MODEL | APPLICATION | OEM NO. | SIZE | DATA acc. | CODE | YEARS |
|--------|---|--|-----------------|--------------|-----------|--------|--------------|
| TOYOTA | Coaster BB BB1#.2#.3# | Transmission rear | 90311-45018 | 45*62*9 | PAYEN | NJ 261 | |
| TOYOTA | Coaster- BB4#,HDB5#,HZB4 #,5# | Steering Worm Gear | | 24*36*7/7.5 | MUSASHI | T1282 | '93.1~ |
| TOYOTA | Coaster- HDB5#,HZB4#,5# | Transmission Front Cover | 90311-35023 | 35*48*6.5 | MUSASHI | T1227 | '93.1~ |
| TOYOTA | Coaster-RB,BB,HB | Crank Shaft Rear | 90311-95003-000 | 95*115*12 | MUSASHI | T1128 | '72~'89.8 |
| TOYOTA | Coaster-RB,BB,HB | Crank Shaft Rear | 90311-95002 | 95*115*12 | MUSASHI | T1128 | '74.2~'88.8 |
| TOYOTA | Coaster-RB,BB,HB | Drive Pinion | 90311-48089 | 48*82*12 | MUSASHI | T1084 | '77.8~ |
| TOYOTA | Coaster-RB,BB,HB | Timing Gear | 90311-45002 | 45*68*12 | MUSASHI | T1077 | '76.12~'84.7 |
| TOYOTA | Coaster-RB,BB,HB | Timing Gear | 90311-50002 | 50*72*12 | MUSASHI | T1132 | '74.2~'82.10 |
| TOYOTA | Coaster-RB,BB,HB | Timing Gear | 90311-50006 | 50*72*12 | MUSASHI | T1132 | '74.2~'82.10 |
| TOYOTA | Corolla CE CE7# | Differential pinion | 90311-38014/14 | 38*65*12/19 | PAYEN | NJ 017 | |
| TOYOTA | Corolla EE EE80.90 | Rear wheel | 90311-41001/03 | 41*55*6 | PAYEN | NJ 708 | |
| TOYOTA | Corolla EE EE9# | | 90311-52006 | 52*66*7.5/12 | PAYEN | NJ 867 | |
| TOYOTA | Corolla EE EE9# | | 90311-56008 | 56*73*8/12.5 | PAYEN | NJ 868 | |
| TOYOTA | Corolla TE TE2# | Rear wheel | 90311-42055 | 42*55*7 | PAYEN | NJ 052 | |
| TOYOTA | Corolla TE TE2# | Steering sector | 90310-28038 | 28*38*7 | PAYEN | NJ 614 | |
| TOYOTA | Corolla TE TE2# | Steering sector | 90310-28038 | 28*38*7 | PAYEN | NJ 614 | |
| TOYOTA | Corolla TE TE2# | Steering Worm | 90310-30035 | 30*40*7 | PAYEN | NJ 615 | |
| TOYOTA | Corolla TE TE7# | Differential | 90311-38057/124 | 38*65*12/19 | PAYEN | NJ 017 | |
| TOYOTA | Corolla(F.W.D.)- EE,AE,CE | Rear Shaft | 90311-41002 | 41*55*7/12 | MUSASHI | T1186 | '84.10~'87.5 |
| TOYOTA | Corolla(F.W.D.)- EE,AE,CE | Rear Shaft | 90311-41004 | 41*55*7/12 | MUSASHI | T1186 | '84.10~'87.5 |
| TOYOTA | Corolla(FWD)- 2E,4E...EE9#,10#,1 11 | Engine Crank Shaft Rear | | 75*100*8.5 | MUSASHI | T1265 | '90.10~ |
| TOYOTA | Corolla(FWD)- 2E,4E...EE9#,10#,1 11 | Engine Crank Shaft Rear | 90311-75007 | 75*100*8.5 | MUSASHI | T1265 | '90.10~ |
| TOYOTA | Corolla(FWD)- AE104,CE104...4W | Wheel Hub Rear Outer | | 52*65*7.5/12 | MUSASHI | T1257 | '91.9~'95 |
| TOYOTA | Corolla(FWD)- AE110,111,EE111 | Transmission & Differential Mission Case | | 34*63*9/15 | MUSASHI | T1176 | '95.5~ |
| TOYOTA | Corolla(FWD)- TT142,AT141,RT14 | Final Drive Diff Side | | 38*63*10/17 | MUSASHI | T1065 | '82.1~'85.8 |
| TOYOTA | Corolla(FWD)- TT142,AT141,RT14 | Wheel Hub Rear Outer | | 48*62*7 | MUSASHI | T1083 | '82.1~'85 |
| TOYOTA | Corolla(R.W.D.)- KE,TE,AE(85,86),C | Drive Pinion | 90311-35127 | 35*55*11 | MUSASHI | T1057 | '70.5~'83 |
| TOYOTA | Corolla(R.W.D.)- KE,TE,AE(85,86),C | Front Wheel | 90311-41123 | 41*53*7 | PAYEN | NJ 104 | |
| TOYOTA | Corolla(R.W.D.)- KE,TE,AE(85,86),C | Rear Shaft Inner | 90311-12055 | 42*55*7 | MUSASHI | T1075 | '70.5~'87 |
| TOYOTA | Corolla(RWD) | Steering Worm | 90311-17052 | 17.4*30*7 | MUSASHI | T1017 | '74.4~'87 |
| TOYOTA | Corolla(RWD)- KE,TE,AE | Transmission Front Oil Pump | | 42*65*12 | MUSASHI | T1258 | '74.4~'81.8 |
| TOYOTA | Corolla(RWD)- KE71,AE70,TE7# | Steering Worm | 90311-17062 | 17.4*30*7 | MUSASHI | T1017 | '79.3~'81.8 |
| TOYOTA | Corona (Sedan 5Door) 3A#,4A#,5A#...AT15 | Engine Crank Shaft Front | | 70*92*8.5 | MUSASHI | T1172 | '83.10~'91.6 |
| TOYOTA | Corona (Sedan 5Door)- | Wheel Hub Rear Inner | | 56*75*6.5/11 | MUSASHI | T1245 | '88.8~'92.2 |
| TOYOTA | Corona 1C 4 CYL Diesel 1839 cc | Timing Cover | 90311-42083 | 42*65*12 | PAYEN | NJ764 | |
| TOYOTA | Corona AT AT150 | Front wheel outer | 04422-20010-52 | 52*68*7.5/12 | PAYEN | NK 098 | |

| CAR | MODEL | APPLICATION | OEM NO. | SIZE | DATA acc. | CODE | YEARS |
|--------|---|-----------------------------|---------------------|---------------|-----------|--------|-------------|
| TOYOTA | Corona AT AT150.160.170 | Transaxle case | 90311-34007 | 33.5*54*9/15 | PAYEN | NJ 704 | |
| TOYOTA | Corona AT AT150.160.170 | Transmission case | 90311-34008 | 34*63*9/15 | PAYEN | NJ 705 | |
| TOYOTA | Corona AT AT175...4WD | Rear wheel inner | 90311-56007 | 56*75*6.5/11 | PAYEN | NK 054 | |
| TOYOTA | Corona AT AT175...4WD | | 90311-52005 | 52*75*7.5/12 | PAYEN | NJ 995 | |
| TOYOTA | Corona CT CT140.141...STD | Steering Sector | 90311-34001 | 34*44*8 | PAYEN | NJ 763 | |
| TOYOTA | Corona CT | Transaxle case | 90311-35007/14 | 35*55*9/15 | PAYEN | NJ 861 | |
| TOYOTA | Corona CT | Transaxle case | 90311-35007/14 | 35*55*9/15.5 | PAYEN | NJ 861 | |
| TOYOTA | Corona KT KT147 | Transmission rear | 90310-32010/74/86 | 32*52*11 | PAYEN | NJ 606 | |
| TOYOTA | Corona(F.W.D.)- AT,ST,CT,ET | Crank Shaft Rear | 90311-80007 | 80*100*8.5 | MUSASHI | T1180 | '87.12~ |
| TOYOTA | Corona(F.W.D.)- AT,ST,CT,ET | Rear Shaft Inner | 90311-56007 | 56*75*6.5/11 | MUSASHI | | '89.11~ |
| TOYOTA | Corona(F.W.D.)- AT,ST,CT,ET | Rear Shaft Outer | 90311-52005 | 52*75*7.5/12 | MUSASHI | | '89.11~ |
| TOYOTA | Corona(F.W.D.)- AT,ST,CT,ET | Transaxle Case | 90311-34007 | 34*54*9/15 | MUSASHI | T1175 | '83.10~ |
| TOYOTA | Corona(F.W.D.)- AT,ST,CT,ET | Transmission Case | 90311-35007 | 35*55*9/15 | MUSASHI | T1196 | '83.1~ |
| TOYOTA | Corona(F.W.D.)- AT,ST,CT,ET | Transmission Case | 90311-35014 | 35*55*9/15 | MUSASHI | T1196 | '83.1~ |
| TOYOTA | Corona(F.W.D.)- AT,ST,CT,ET | Transmission Case | 90311-35007 | 35*55*9/15.5 | MUSASHI | T1196 | '83.1~ |
| TOYOTA | Corona(F.W.D.)- AT,ST,CT,ET | Transmission Case | 90311-35014 | 35*55*9/15.5 | MUSASHI | T1196 | '83.1~ |
| TOYOTA | Corsa 2A 4 CYL (OHC) 1295 cc | Cam Shaft | 90311-35003/08/13 | 35*49*6 | PAYEN | NJ 353 | |
| TOYOTA | Cressida 1GEU 6 CYL (OHC) 1988 cc | Cam Shaft | 90311-38017/18/34/ | 38*50*8 | PAYEN | NJ 347 | |
| TOYOTA | Cressida 1GGEU 6 CYL (DOHC) 1988 | Crank Shaft Rear | 90311-75004 | 75*100*8.5 | PAYEN | NJ 407 | |
| TOYOTA | Cressida 1GGEU 6 CYL (DOHC) 1988 | | 90311-75004 | 75*100*8.5 | PAYEN | NJ 407 | |
| TOYOTA | Cressida GX GX81 | | 90311-57001 | 57*81*8/11 | PAYEN | NJ 997 | |
| TOYOTA | Cressida GX GX81 | | 90311-63001 | 63*90*7/10 | PAYEN | NJ 998 | |
| TOYOTA | Cressida MX MX31.33.41.43.61.6 3.71 | Differential sode | 90311-38001 | 38*63*10/16.5 | PAYEN | NJ 522 | |
| TOYOTA | Cressida RX RX31.41.63 | Differential side | 90311-38011 | 38*63*10/16.5 | PAYEN | NJ 522 | |
| TOYOTA | Cressida-Mark II | Engine Oil Pump | | 18*30*5 | MUSASHI | T1291 | '88.8~ |
| TOYOTA | CRESTA | Transmission | 04331-30020 | 38*58*18.3 | MUSASHI | | |
| TOYOTA | Crown | Engine Crank Shaft Rear | | 85*105*10 | MUSASHI | T1270 | '91.2~ |
| TOYOTA | Crown 5R 4 CYL (OHV) 1994 cc | Timing Cover | 90311-45002/06/11/2 | 45*68*12 | PAYEN | NJ 243 | |
| TOYOTA | Crown RS | Transmission | 90311-32016 | 32*48*7 | PAYEN | NJ 268 | |
| TOYOTA | Crown- 5MGEU...MS112,12 | Engine Timing Gear Cover | | 48*70*12 | MUSASHI | T1233 | '81.8~'84.8 |
| TOYOTA | DA SERIES D 6 CYL Diesel 5890 cc | Timing Cover | 90311-65033 | 65*95*14 | PAYEN | NJ 095 | |
| TOYOTA | DA SERIES DA100.11# | Rear wheel outer | 90311-48027 | 48*62*9 | PAYEN | NJ 562 | |
| TOYOTA | DA SERIES DA11#.12#...single speed | | 90033-11020 | 65*95*14/22 | PAYEN | NJ 773 | |
| TOYOTA | DYNA | Drive Pinion | 90311-58002 | 58*102*12 | MUSASHI | T1184 | '82.4~'88.8 |

| CAR | MODEL | APPLICATION | OEM NO. | SIZE | DATA acc. | CODE | YEARS |
|--------|--|---------------------------------------|-------------|----------------|-----------|--------|--------------|
| TOYOTA | DYNA | Engine Crank Shaft Rear | | 80*100*10 | MUSASHI | T1280 | '90.4~ |
| TOYOTA | DYNA | Engine Timing | | 58*75*9/14.5 | MUSASHI | H3095 | '83.4~ |
| TOYOTA | DYNA | Transmission | | 45*62*9 | MUSASHI | T1076 | '77.8~'87.8 |
| TOYOTA | DYNA | Transmission | | 45*62*9 | MUSASHI | T1076 | '77.8~'87.8 |
| TOYOTA | DYNA BU BU40.41.5# | Differential pinion | 90311-58002 | 58*102*12 | PAYEN | NJ 869 | |
| TOYOTA | DYNA RU RU1#.2#.3# | Rear wheel inner | 42404-36010 | 75*100*13 | PAYEN | NJ 433 | |
| TOYOTA | DYNA WU WU26.40.50 | Front wheel | 90033-19001 | 101*114*10 | PAYEN | NJ 420 | |
| TOYOTA | DYNA- 1W...WU75,85,9# | Engine Crank Shaft Rear | | 100*120*13/18 | MUSASHI | H3096 | '83.4~ |
| TOYOTA | DYNA- BU20,30,RU20,30,J U20...ST,T2,TW2 | Steering Sector | 90310-32024 | 32*44*9 | MUSASHI | T1007 | '79.10~'88.9 |
| TOYOTA | DYNA- BU40,41,5#,HU26,4 0,50,WU26,40,50 | Final Drive Pinion | | 58*102*12 | MUSASHI | T1184 | '82.4~'84 |
| TOYOTA | DYNA- BU6#,70,8#...DSL... (CBU,IV3) | Transmission Front Cover | | 32*48*8 | MUSASHI | T1054 | '84.9~'85.8 |
| TOYOTA | DYNA- BU85...(T2,T3)...5F. ..20T...DSL | Steering Sector Shaft | | 32*52*9 | MUSASHI | ※ | '87.8~'88.8 |
| TOYOTA | DYNA- RU,JU,BU,HU,WU, | Rear Wheel Outer | 90310-41001 | 41*47/53*17 | MUSASHI | T1165 | '82.4~'84.9 |
| TOYOTA | ESTIMA- CXR,TCR | Wheel Hub Front Outer | | 61*76*7/10 | MUSASHI | T1231 | '92.1~ |
| TOYOTA | ESTIMA- 2TZFE...TCR1#,2# | Engine Crank Shaft Rear | | 88*106*8.5 | MUSASHI | ※ | '92.1~ |
| TOYOTA | ESTIMA- CXR2#,TCR2#(4W | Wheel Hub Front Inner | 90310-40001 | 56*78*7.5/13.5 | MUSASHI | T1232 | '92.1~ |
| TOYOTA | F 6 cyl (ohv) 3878 | Crank Shaft Rear | 90311-99065 | 100*120*11 | PAYEN | NJ 055 | |
| TOYOTA | HI ACE (VAN,WAGON)- YH10#,11#,RZH10# ,11# | Steering Rack Housing | | 15*25*7 | MUSASHI | T1016 | '89.8~'93 |
| TOYOTA | HI ACE(Truck) | Engine Crank Shaft Rear | 90311-85001 | 85*105*13 | MUSASHI | T1137 | '79.12~'84.2 |
| TOYOTA | HI ACE(VAN,WAGON) - YH,LH,KZH,RZH | Steering Adjuster Plug; Control Valve | 90311-19002 | 19*32*7/8 | MUSASHI | T1154 | '82.12~'89.8 |
| TOYOTA | HI LUX | Engine Crank Shaft Rear | | 80*100*10 | MUSASHI | T1280 | '90.4~ |
| TOYOTA | HI LUX- 1KZTE...KZN130 | Engine Timing Case | 90311-50017 | 50*68*9/14.5 | MUSASHI | ※ | '93.8~ |
| TOYOTA | HI LUX-RN,YN,LN | Drive Pinion | 90311-38133 | 38*74*11 | MUSASHI | T1067 | '72.5~'88.8 |
| TOYOTA | HI LUX-RN,YN,LN | Drive Pinion | 90311-38035 | 38*74*11/18 | MUSASHI | T1203 | '88.8~'88.9 |
| TOYOTA | HI LUX-RN,YN,LN | Front Drive Shaft | 90311-33085 | 33*44*8 | MUSASHI | T1143 | '79.10~'88.9 |
| TOYOTA | HI LUX-RN,YN,LN | Front Wheel | 90311-50005 | 50*68*9 | MUSASHI | T1088 | '75.11~'88.9 |
| TOYOTA | HI LUX-RN,YN,LN | Front Wheel | 90311-50136 | 50*68*9 | MUSASHI | T1088 | '75.11~'88.9 |
| TOYOTA | HI LUX-RN,YN,LN | Front Wheel | 90311-62001 | 62*85*10 | MUSASHI | T1095 | '79.10~'88.9 |
| TOYOTA | HI LUX-RN,YN,LN | Front Wheel | 90311-66001 | 66*85*8/10 | MUSASHI | T1187 | '85.8~'89.4 |
| TOYOTA | HI LUX-RN,YN,LN | Rear Shaft Inner | 90310-50039 | 50*70*9 | MUSASHI | T1086 | '72.5~'79.12 |
| TOYOTA | HI LUX-RN,YN,LN | Rear Shaft Inner | 90310-50001 | 50*70*9 | MUSASHI | T1086 | '72.5~'79.12 |
| TOYOTA | HI LUX-RN,YN,LN | Rear Shaft Outer | 90313-48001 | 48*62*9/24 | MUSASHI | T1115 | '72.5~'79.12 |

| CAR | MODEL | APPLICATION | OEM NO. | SIZE | DATA acc. | CODE | YEARS |
|--------|--|----------------------------|---------------------|------------|-----------|--------|--------------|
| TOYOTA | HI LUX- RN,YN,LNHI LUX- RN,YN,LNHI LUX- RN,YN,LNHI LUX- RN,YN,LNHI LUX- RN,YN,LNHI LUX- | Drive Pinion (Front) | 90311-38134 | 38*74*11 | MUSASHI | T1157 | '79.10~'89.4 |
| TOYOTA | HI LUX- RN,YN,LNHI LUX- RN,YN,LNHI LUX- RN,YN,LNHI LUX- RN,YN,LNHI LUX- | Timing Gear Cover | 90311-45069 | 45*68*12 | MUSASHI | T1077 | '72.5~'83.10 |
| TOYOTA | HI LUX- YN10#,LN100,106,1 07 | Transfer Adapter | | 32*52*8 | MUSASHI | T1163 | '88.9~ |
| TOYOTA | HI-ACE | Transmission | 90303-38010 | 30*45*8 | MUSASHI | | |
| TOYOTA | HI-ACE LH LH2#.30.40.5#.6#.7 #.80 | Steering Worm | 90311-18001/02 | 18*30*8 | PAYEN | NJ 438 | |
| TOYOTA | HI-ACE LH LH2#.30.40.5#.6#.7 #.80 | Steering Worm | 90311-18001/02 | 18*30*8 | PAYEN | NJ 438 | |
| TOYOTA | HI-ACE RH RH11.2#.3#.4# | Front wheel | 90311-50005/136 | 50*68*9 | PAYEN | NJ 069 | |
| TOYOTA | HI-ACE YH YH57...4WD | | 90311-32012 | 32*53*7 | PAYEN | NK 048 | |
| TOYOTA | HI-ACE YH YH8# | Steering sector | 90310-32024 | 32*44*9 | PAYEN | NJ 436 | |
| TOYOTA | HI-LUX 18R 4 CYL (OHC) 1968 cc | Timing Cover | 90311-45002/06/11/2 | 45*68*12 | PAYEN | NJ 243 | |
| TOYOTA | HI-LUX 3VZE V6 CYL (OHV) 2958 cc | Crank Shaft Rear | 90311-40006/13 | 40*55*6 | PAYEN | NK 050 | |
| TOYOTA | HI-LUX 3Y 4 CYL (OHC) 1998 cc | | 90311-80003/05/07 | 80*100*8.5 | PAYEN | NJ 360 | |
| TOYOTA | HI-LUX 8R 4 CYL (OHC) 1858 cc | | 90311-80001/02 | 80*100*12 | PAYEN | NJ 030 | |
| TOYOTA | HI-LUX L 4 CYL Diesel 2188 cc | Cam Shaft | 90311-42001 | 42*60*9 | PAYEN | NJ 358 | |
| TOYOTA | HI-LUX L 4 CYL Diesel 2188 cc | Timing Cover | 90311-42003/07/08/ | 42*60*7 | PAYEN | NJ 344 | |
| TOYOTA | HI-LUX LN LN36.46.60.65.10#.. .4WD | Front drive shaft | 90311-33085 | 33*44*8 | PAYEN | NJ 520 | |
| TOYOTA | HI-LUX RN RN2# | Steering Worm | 90311-17062/92 | 17.4*30*7 | PAYEN | NJ 518 | |
| TOYOTA | HI-LUX YN YN5# | Transmission rear | 90311-38043 | 38*58*11 | PAYEN | NJ 609 | |
| TOYOTA | HI-LUX YN YN5#.8# | Steering Worm | 90311-19001 | 19*32*8 | PAYEN | NJ 444 | |
| TOYOTA | Land Cruiser | Engine Cam Shaft | 90311-32018 | 32*46*6 | MUSASHI | T1262 | '90.4~'90.1 |
| TOYOTA | Land Cruiser | Engine Crank Shaft Rear | 04422-32010 | 105*120*11 | MUSASHI | T1217 | '85.6 |
| TOYOTA | Land Cruiser | Engine Crank Shaft Rear | 04422-32010 | 105*120*11 | MUSASHI | T1217 | '85.6 |
| TOYOTA | Land Cruiser | Engine Crank Shaft Rear | | 99*119*9.5 | MUSASHI | T1294 | '92.8~ |
| TOYOTA | Land Cruiser | Steering Worm | 90311-18125 | 18*30*8 | MUSASHI | | |
| TOYOTA | Land Cruiser | Steering Worm | 90311-18021 | 18*30*8 | MUSASHI | | |
| TOYOTA | Land Cruiser | Transfer Case | 90316-48003 | 48*72*11 | MUSASHI | T1273 | '88.1~'90.1 |
| TOYOTA | Land Cruiser B 4 CYL Diesel 2977 cc | Timing Cover | 90311-50002/06/07/ | 50*72*12 | PAYEN | NJ 239 | |
| TOYOTA | Land Cruiser BJ | Steering sector | 90311-36104 | 36*50*7 | PAYEN | NJ 592 | |
| TOYOTA | Land Cruiser FJ FJ4#.5# | Front wheel | 90312-55010 | 55*82*10 | PAYEN | NJ 047 | |

| CAR | MODEL | APPLICATION | OEM NO. | SIZE | DATA acc. | CODE | YEARS |
|--------|--|--|-------------------|-------------|-----------|--------|--------------|
| TOYOTA | Land Cruiser FJ FJ4#.6# | Output shaft front | 90311-48002/04 | 48*70*12 | PAYEN | NJ 042 | |
| TOYOTA | Land Cruiser FJ FJ4#.6# | | 90311-48003 | 48*62*8 | PAYEN | NJ 863 | |
| TOYOTA | Land Cruiser FJ FJ4#.6# | | 90311-48007/08/12 | 48*72*9 | PAYEN | NJ 866 | |
| TOYOTA | Land Cruiser FJ | | 90311-48010 | 48*62*8/13 | PAYEN | NJ 865 | |
| TOYOTA | Land Cruiser FJ | Output shaft front | 90311-48009 | 48*74*10/15 | PAYEN | NJ 864 | |
| TOYOTA | Land Cruiser- FJ,BJ,HJ,LJ,HZJ,KZ J,PZJ,FZJ,HDJ | Front Axle Hub Outer | 90311-62003 | 62*74*8 | MUSASHI | T1235 | '90.1~'95.1 |
| TOYOTA | Land Cruiser- FJ,BJ,HJ,LJ,HZJ,KZ J,PZJ,FZJ,HDJ | Rear Axle Shaft Inner | 90310-58002 | 58*70*7 | MUSASHI | T1237 | '90.4~ |
| TOYOTA | Land Cruiser HJ HJ6#.8# | Front wheel | 90311-62001/147 | 62*85*10 | PAYEN | NJ 062 | |
| TOYOTA | Land Cruiser- 3B.13B...BJ7# | Engine Timing Cover | | 50*72*9/14 | MUSASHI | T1277 | '88.8~'90 |
| TOYOTA | Land Cruiser- FJ,BJ,HJ,LJ | Front Drive Shaft | 90310-35005 | 35*50*9.5 | MUSASHI | | '90.1~ |
| TOYOTA | Land Cruiser- FJ,BJ,HJ,LJ | Front Drive Shaft | 90311-35024 | 35*50*9.5 | MUSASHI | | '90.1~ |
| TOYOTA | Land Cruiser- FJ,BJ,HJ,LJ | Front Wheel | 90312-55010 | 55*82*10 | MUSASHI | T1149 | '69.3~'75.9 |
| TOYOTA | Land Cruiser- FJ,BJ,HJ,LJ | Output Shaft Bearing Front Rearainer | 90311-48002 | 48*74*10 | MUSASHI | T1147 | '80.8~'84.11 |
| TOYOTA | Land Cruiser- FJ,BJ,HJ,LJ | Output Shaft Bearing Front Rearainer | 90311-48009 | 48*74*10/15 | MUSASHI | T1190 | '84.11~ |
| TOYOTA | Land Cruiser- FJ,BJ,HJ,LJ | Output Shaft Retainer | 90311-48010 | 48*62*8/13 | MUSASHI | T1191 | '84.11~ |
| TOYOTA | Land Cruiser- FJ,BJ,HJ,LJ | Rear Shaft Outer | 90310-35001 | 35*41*5.5/9 | MUSASHI | T1008 | '79.9~'90.1 |
| TOYOTA | Land Cruiser- FJ,BJ,HJ,LJ | Transier Extentron Housing | 90311-50014 | 50*70*10/16 | MUSASHI | | '90.1 |
| TOYOTA | Land Cruiser- FJ,BJ,HJ,LJ | Transmission Front | 90311-28003 | 28.6*43*6.5 | MUSASHI | T1044 | '69.3~'85.10 |
| TOYOTA | Land Cruiser- FJ,BJ,HJ,LJ | Transmission Front | 90311-32013 | 32*48*7 | MUSASHI | T1215 | '85.10~ |
| TOYOTA | Land Cruiser- FJ,BJ,HJ,LJ | Transter Case | 90311-42014 | 42*60*9 | MUSASHI | T1156 | '69.3~'80.7 |
| TOYOTA | Land Cruiser- FJ,BJ,HJ,LJ | Transter Case | 90311-48003 | 48*62*8 | MUSASHI | T1148 | '90.1~ |
| TOYOTA | Land Cruiser- FJ,BJ,HJ,LJ | Transter Case | 90311-48016 | 48*62*8 | MUSASHI | T1148 | '90.1~ |
| TOYOTA | Land Cruiser- FJ,BJ,HJ,LJ | Transter Case | 90311-48012 | 48*72*8.5 | MUSASHI | T1162 | '82.1~'88.8 |
| TOYOTA | Land Cruiser- FJ,BJ,HJ,LJ | Transter Case | 90311-48008 | 48*72*8.5 | MUSASHI | T1162 | '82.1~'88.8 |
| TOYOTA | Land Cruiser- FJ,BJ,HJ,LJ | Transter Case | 90311-48007 | 48*72*8.5 | MUSASHI | T1162 | '82.1~'88.8 |
| TOYOTA | Land Cruiser-FJ55 | Steering Worm Gear | | 18*32*7 | MUSASHI | T1018 | '69.3~'72.4 |
| TOYOTA | Land Cruiser- FZJ80,HDJ81,HZJ8 1,FJ80 | Final Drive Pinion (Front) | | 38*74*11/18 | MUSASHI | T1203 | '90.1~ |
| TOYOTA | Land Cruiser- HZJ73,77...ZX | Rear Axle Hub | | 62*85*8/17 | MUSASHI | T1236 | '90.1~ |

| CAR | MODEL | APPLICATION | OEM NO. | SIZE | DATA acc. | CODE | YEARS |
|--------|--|---------------------------|----------------|-------------|-----------|--------|---------------|
| TOYOTA | Lite Ace, Town Ace (Truck) - KM, TM, YM, CM | Cam Shaft | 90311-38025 | 38*50*6 | MUSASHI | T1210 | '85.1~ |
| TOYOTA | Lite Ace, Town Ace (Truck) - KM, TM, YM, CM | Cam Shaft | 90311-38017 | 38*50*8 | MUSASHI | T1192 | '82.10~'85.1 |
| TOYOTA | Lite Ace, Town Ace (Truck) - KM, TM, YM, CM | Drive Pinion | 90311-36133 | 38*74*11 | MUSASHI | T1067 | '70.11~'86.10 |
| TOYOTA | Lite Ace, Town Ace (Truck) - KM, TM, YM, CM | Timing Gear Cover | 90311-42007 | 42*60*7 | MUSASHI | T1178 | '82.10~ |
| TOYOTA | Lite Ace, Town Ace (Truck) - KM, TM, YM, CM | Transmission Front | 90311-30010 | 30*45*8 | MUSASHI | T1050 | '81.1~'86.10 |
| TOYOTA | Lite Ace, Town Ace (Truck) - KM, TM, YM, CM | Transmission Front | 90311-30115 | 30*45*8 | MUSASHI | T1050 | '81.1~'86.10 |
| TOYOTA | Lite Ace, Town Ace (Truck) - KM, TM, YM, CM | Transmission Front | 90311-32105 | 32*48*8 | MUSASHI | T1054 | '71.11~'86.10 |
| TOYOTA | Lite-Ace | Steering Cector | 90311-28027 | 28*40*8 | MUSASHI | | |
| TOYOTA | Lite-Ace 5K 4 CYL (OHV) 1486 cc | | 90311-38022 | 38.5*58*8.5 | PAYEN | NJ 719 | |
| TOYOTA | Lite-Ace KM KM1# | Front wheel | 90311-40108 | 40*52*7 | PAYEN | NJ 011 | |
| TOYOTA | Lite-Ace KM | Steering rack | 90311-15001 | 15*25*7 | PAYEN | NJ 762 | |
| TOYOTA | Lite-Ace YM YM2#.30.55 | | 90311-48001 | 48*62*7/8.8 | PAYEN | NJ 557 | |
| TOYOTA | Lite-Ace YM YM20.21...single | Rear wheel inner | 90311-52059 | 52*65*9 | PAYEN | NJ 068 | |
| TOYOTA | Lite-Ace YM | | 90311-66002 | 66*80*9 | PAYEN | NJ 141 | |
| TOYOTA | Lite-Ace, HI-LUX, TOYO-ACE, HI-ACE, Mark II, Crown | Transmission Rear | 04332-30010 | 38*58*18.3 | MUSASHI | T1159 | |
| TOYOTA | LJ7# | Differential Dinion front | 90311-38134 | 48*74*10/15 | PAYEN | NJ864 | 10/85-on |
| TOYOTA | LJ7# | Differential Dinion front | 90311-38079 | 48*74*10/15 | PAYEN | NJ864 | 10/85-on |
| TOYOTA | LJ7# | Differential Dinion front | 90311-38003 | 48*74*10/15 | PAYEN | NJ864 | 10/85-on |
| TOYOTA | LJ7# | Differential Dinion rear | 90311-38010 | 48*74*10/15 | PAYEN | NJ864 | 10/85-on |
| TOYOTA | Mark II | Diff Drive Dinion | 90311-38101 | 38*74*11 | MUSASHI | | |
| TOYOTA | Mark II | Transmission | 90311-38005 | 38*58*18.5 | MUSASHI | | |
| TOYOTA | Mark II.Cressida-RX, MX, TX, LX, SX, G X, YX | Drive Pinion | 90311-38010 | 38*74*11 | MUSASHI | T1067 | '82.8~'88 |
| TOYOTA | Mark II.Cressida-RX, MX, TX, LX, SX, G X, YX | Front Wheel | 90311-48013 | 48*73*7 | MUSASHI | T1209 | '88.8~ |
| TOYOTA | Mark II.Cressida-RX, MX, TX, LX, SX, G X, YX | Rear Shaft Inner | 90311-57001 | 57*81*8/11 | MUSASHI | T1208 | '88.8~ |
| TOYOTA | Mark II.Cressida-RX, MX, TX, LX, SX, G X, YX | Rear Shaft Outer | 90311-63001 | 63*90*7/10 | MUSASHI | T1207 | '88.8~ |
| TOYOTA | Mark II.Cressida-RX, MX, TX, LX, SX, G X, YX | Transmission Rear | 90311-38140 | 38*58*11 | MUSASHI | T1125 | '76.12~'80 |
| TOYOTA | MR-2 AW AW1# | Front wheel | 90311-41002/04 | 41*55*7/12 | PAYEN | NJ 660 | |
| TOYOTA | MR2-AW, SW | Cam Shaft | 90311-35022 | 35*49*6 | MUSASHI | T1173 | '84.6~'89.12 |

| CAR | MODEL | APPLICATION | OEM NO. | SIZE | DATA acc. | CODE | YEARS |
|--------|---|-----------------------------|---------------------|--------------|-----------|--------|---------------|
| TOYOTA | Pick up 2K 4 CYL (OHV) 993 cc | | 90311-70001/03/04/ | 70*92*8.5 | PAYEN | NJ 001 | |
| TOYOTA | PREVIA 2TZ 4 CYL (DOHC) 2438 cc | Timing Cover | 90311-48014 | 48*68*7 | PAYEN | NJ 200 | |
| TOYOTA | Publica KP KP3#.50 | Differential pinion | 90311-35071/127/13 | 35*55*11 | PAYEN | NJ 607 | |
| TOYOTA | Publica UP UP3# | Transmission | 90310-20026 | 20*30*7 | PAYEN | NJ 901 | |
| TOYOTA | Publica-UP,KP | Crank Shaft Rear | 90311-70075 | 70*92*12 | MUSASHI | T1121 | '69.12~'82.4 |
| TOYOTA | Publica-UP,KP | Crank Shaft Rear | 90311-70004 | 70*92*8.5 | MUSASHI | T1172 | '82.4~ |
| TOYOTA | Publica-UP,KP | Drive Pinion | 90311-35071 | 35*55*11 | MUSASHI | T1057 | '69.4~ |
| TOYOTA | Publica-UP,KP | Rear Shaft | 90311-42055 | 42*55*7 | MUSASHI | T1075 | '69.11~'73.10 |
| TOYOTA | Publica-UP,KP | Steering Sector | 90310-28033 | 26*35*7 | MUSASHI | T1048 | '72.1~ |
| TOYOTA | Publica-UP,KP | Transmission | 90310-20026 | 20*30*7 | MUSASHI | T1003 | '69.4~'71.12 |
| TOYOTA | Publica-UP,KP | Transmission | 90311-32085 | 32*52*11 | MUSASHI | T1052 | '69.4~ |
| TOYOTA | Publica-UP,KP | Transmission | 90311-32074 | 32*52*11 | MUSASHI | T1052 | '69.4~ |
| TOYOTA | PUBRICA | Crank Shaft | 90311-70105 | 70*92*12 | MUSASHI | | |
| TOYOTA | PUBRICA | Crank Shaft | 90311-70003 | 70*92*12 | MUSASHI | | |
| TOYOTA | PUBRICA | Crank Shaft | 90311-70005 | 70*92*8.5 | MUSASHI | | |
| TOYOTA | PUBRICA | Front Wheel | 90312-40011 | 40*52*7 | MUSASHI | | |
| TOYOTA | RETEN SECTOR TOYOTA HILUX 22R RN106 4X4 | Power Steering Gear Housing | 90311-36005 | 36*44*5 | MUSASHI | | '90.1~ |
| TOYOTA | SCEPTER-3VZFE...VCV1# | Engine Oil Pump | | 40*55*6 | MUSASHI | T1301 | '92.7~ |
| TOYOTA | Starlet NP NP7# | Front wheel outer | 04422-10010-51 | 51*63*7.5/10 | PAYEN | NK 096 | |
| TOYOTA | Starlet NP NP7# | Rear wheel | 90311-36001 | 36*50*7 | PAYEN | NJ 563 | |
| TOYOTA | Starlet(F.W.D.) | Crank Shaft Front | 90311-35017 | 35*49*6 | MUSASHI | T1173 | '84.10~'86.12 |
| TOYOTA | Starlet(F.W.D.) | Crank Shaft Rear | 90311-80005 | 80*100*8.5 | MUSASHI | T1180 | '86.12~ |
| TOYOTA | Starlet(F.W.D.) | Rear Shaft | 90311-36001 | 36*50*7 | MUSASHI | T1124 | '84.10~ |
| TOYOTA | Starlet(F.W.D.) | Transmission | 90311-34008 | 34*63*9/15 | MUSASHI | T1176 | '84.10~ |
| TOYOTA | Starlet(F.W.D.) | Transmission | 90311-34008 | 34*63*9/15.5 | MUSASHI | T1176 | '84.10~ |
| TOYOTA | Starlet(R.W.D.)-KP | Crank Shaft Rear | 90311-70120 | 70*92*12 | MUSASHI | T1121 | '73.4~'82.5 |
| TOYOTA | Starlet(R.W.D.)-KP | Crive Pinion | 90311-35131 | 35*55*11 | MUSASHI | T1057 | '73.4~'84 |
| TOYOTA | Starlet(R.W.D.)-KP | Steering Rack Housing | 90311-15001 | 15*25*7 | MUSASHI | T1016 | '78.2~'84 |
| TOYOTA | Starlet(R.W.D.)-KP | Steering Sector | 90310-28038 | 28*38*7 | MUSASHI | T1048 | '73.4~'78.1 |
| TOYOTA | Starlet(R.W.D.)-KP | Steering Sector | 90310-28038 | 28*38*7 | MUSASHI | T1048 | '73.4~'78.1 |
| TOYOTA | Starlet(R.W.D.)-KP | Steering Sector | 90310-28038 | 28*38*7 | MUSASHI | T1048 | '73.4~'78.1 |
| TOYOTA | Starlet(R.W.D.)-KP | Steering Worm | 90310-30035 | 30*40*7 | MUSASHI | T1140 | '73.4~'78.1 |
| TOYOTA | Starlet(R.W.D.)-KP | Transmission | 90311-32086 | 32*52*11 | MUSASHI | T1052 | '73.4~'84 |
| TOYOTA | Starlet(RWD)- KP | Engine Timing Gear Cover | | 38.5*58*8.5 | MUSASHI | T1171 | '82.5~'84 |
| TOYOTA | Stout PK PK101 | Transmission | 90311-25001/003/141 | 25*38*7 | PAYEN | NJ 118 | |
| TOYOTA | Stout PK | Rear wheel outer | 90311-35038 | 35*44*7 | PAYEN | NJ 012 | |
| TOYOTA | Stout PK PK101.11# | | 90311-28003/04 | 28.6*43*6.5 | PAYEN | NJ 439 | |
| TOYOTA | Stout PK PK11# | Front wheel | 90311-50003 | 50*73*9 | PAYEN | NJ 710 | |
| TOYOTA | Stout-RK | Crank Shaft Rear | 90311-60001 | 80*100*12 | MUSASHI | T1129 | '67.9~ |
| TOYOTA | Stout-RK | Crank Shaft Rear | 90311-60002 | 80*100*12 | MUSASHI | T1129 | '67.9~ |
| TOYOTA | Stout-RK | Drive Pinion | 90311-38028 | 38*74*11 | MUSASHI | T1067 | '67.9~'79.2 |
| TOYOTA | Stout-RK | Drive Pinion | 90311-48135 | 48*82*12 | MUSASHI | T1084 | '79.3~ |
| TOYOTA | Stout-RK | Front Wheel | 90311-50003 | 50*73*9 | MUSASHI | T1133 | '79.3~ |
| TOYOTA | Stout-RK | Rear Wheel Inner | 90311-75003 | 75*108*10/20 | MUSASHI | T1170 | '85.2~ |
| TOYOTA | Stout-RK | Rear Wheel Outer | 90311-35038 | 35*44*7 | MUSASHI | T1056 | '67.9~'79.2 |
| TOYOTA | Stout-RK | Rear Wheel Outer | 90310-38033 | 38*44/47*18 | MUSASHI | T1068 | '79.3~ |
| TOYOTA | Stout-RK | Steering Sector | 90311-32014 | 32*44*9 | MUSASHI | T1007 | '79.10~'88.9 |
| TOYOTA | Stout-RK | Timing Gear | 90311-45069-000 | 45*68*12 | MUSASHI | T1077 | '77.8~'84 |
| TOYOTA | Stout-RK | Timing Gear | 90311-45002-000 | 45*68*12 | MUSASHI | T1077 | '77.8~'84 |
| TOYOTA | Stout-RK | Timing Gear | 90311-45006 | 45*68*12 | MUSASHI | T1077 | '75.11~ |
| TOYOTA | Stout-RK | Timing Gear | 90311-15069 | 45*68*12 | MUSASHI | T1077 | '73.8~'82.10 |
| TOYOTA | Stout-RK | Transmission | 90311-38093 | 38*65*9 | MUSASHI | T1062 | '67.9~ |
| TOYOTA | Stout-RK | Transmission | 90311-38007 | 38*65*9 | MUSASHI | T1062 | '67.9~ |
| TOYOTA | Supra-GA,MA | Crank Shaft Rear | 90311-75004 | 75*100*8.5 | MUSASHI | T1211 | '88.5~'89.10 |

| CAR | MODEL | APPLICATION | OEM NO. | SIZE | DATA acc. | CODE | YEARS |
|--------|---|-----------------------------|-------------|---------------|-----------|--------|---------------|
| TOYOTA | Supra-GA,MA | Drive Pinion | 90311-38079 | 38*74*11 | MUSASHI | T1067 | '73.8~'85.8 |
| TOYOTA | Supra-GA,MA | Fear Drive Pinion | 90311-35133 | 38*74*11 | MUSASHI | T1067 | '69.3~ |
| TOYOTA | Supra-GA,MA | Timing Gear Case | 90311-42003 | 42*60*7 | MUSASHI | T1178 | '82.2~'89.3 |
| TOYOTA | TA57C | Rear Wheel Outer | 90311-48122 | 48*62*7 | PAYEN | NJ066 | 8/80-82 |
| TOYOTA | Tercel AL AL1#.2# | Transmission in | 90311-26001 | 26*48*7 | PAYEN | NJ 703 | |
| TOYOTA | Tercel EL EL3# | Front wheel | 90311-54003 | 54*66*7.5/10 | PAYEN | NJ 996 | |
| TOYOTA | Tercel,Corsa-AL,EL,NL | Wheel Hub Rear | 90311-38037 | 38*52*7 | MUSASHI | T1218 | '90.9~'94.9 |
| TOYOTA | Tercel,Corsa,Corolla II,Sprinter Carib-AL,EL,NL | Differential Side | 90311-32006 | 32*48*9/15.5 | MUSASHI | T1120 | '78.8~ |
| TOYOTA | Tercel,Corsa,Corolla II,Sprinter Carib-AL,EL,NL | Front Wheel (Drive Shaft) | 90311-56006 | 56*73/77.7*14 | MUSASHI | T1198 | '86.5~ |
| TOYOTA | Tercel,Corsa,Corolla II,Sprinter Carib-AL,EL,NL | Front Wheel (Hub) | 90311-54003 | 54*66*7.5/10 | MUSASHI | T1197 | '85.5~ |
| TOYOTA | Town Ace (Van .Wagon).Master Ace. SURF-KR,YR,CR,TR,RR | Crank Shaft Rear | 90311-90003 | 90*110*8.5/10 | MUSASHI | T1212 | '82.10~ |
| TOYOTA | Town Ace (Van .Wagon).Master Ace. SURF-KR,YR,CR,TR,RR | Front Wheel | 90311-48122 | 48*62*7 | MUSASHI | T1083 | '76.10~'82.10 |
| TOYOTA | Town Ace (Van .Wagon).Master Ace. SURF-KR,YR,CR,TR,RR | Front Wheel | 90311-66002 | 66*80*9 | MUSASHI | T1201 | '85.10~ |
| TOYOTA | Town Ace (Van .Wagon).Master Ace. SURF-KR,YR,CR,TR,RR | Rear Shaft Inner | 90311-58001 | 58*78*8 | MUSASHI | T1134 | '79.11~'82.10 |
| TOYOTA | Town Ace (Van .Wagon).Master Ace. SURF-KR,YR,CR,TR,RR | Rear Shaft Outer | 90313-48005 | 48*62*9/24 | MUSASHI | T1115 | '78.8~'82.10 |
| TOYOTA | Town Ace (Van .Wagon).Master Ace. SURF-KR,YR,CR,TR,RR | Steering Sector | 90311-34001 | 34*44*8 | MUSASHI | | '82.11~'85.8 |
| TOYOTA | Town Ace, Master Ace | Steering Worm | 90311-19008 | 19*38*7 | MUSASHI | | '82.11~'85.8 |
| TOYOTA | Town Ace, Master Ace | Steering Worm | 90311-19008 | 19*38*7 | PAYEN | NJ858 | |
| TOYOTA | Town Ace.Master Ace-KR,TR,RR,YR,CR | Steering Sector Shaft | | 32*44*8 | MUSASHI | | '82.11~'85.8 |
| TOYOTA | Town Ace-Master Ace-2C#...CR2#,3# | Engine Oil Pump | | 20*32*5 | MUSASHI | T1261 | '88.8~'89.5 |
| TOYOTA | Town Ace-Master Ace-KR27,CR2#,3#,YR2 #,3# | Transmission Front Oil Pump | | 38*55*8.5 | MUSASHI | T1256 | '82.11~ |
| TOYOTA | Town Ace-Master Ace-YR2#,30,CR2#,3#,K R2#...Except Z | Steering Bearing Guide Nut | | 25*38*7/7.8 | MUSASHI | T1244 | '85.8~ |
| TOYOTA | Town Ace-Master Ace-YR2#,CR2# | Steering Gear Housing | | 32*42*5 | MUSASHI | T1241 | '82.11~'85.8 |

| CAR | MODEL | APPLICATION | OEM NO. | SIZE | DATA acc. | CODE | YEARS |
|--------|---------------------------------------|----------------------|-------------------|-------------|-----------|--------|--------------|
| TOYOTA | TOWN-ACE 2C 4 CYL Diesel 1974 cc | Crank Shaft Rear | 90311-90002/03/08 | 90*110*8.5 | PAYEN | NJ 346 | |
| TOYOTA | TOWN-ACE 2C 4 CYL Diesel 1974 cc | Oil Pump | 90029-21007/20 | 20*32*5 | PAYEN | NJ 654 | |
| TOYOTA | Toy Ace JY JY16...2T | Differential pinion | 90311-48089/135 | 48*82*12 | PAYEN | NJ 523 | |
| TOYOTA | Toy Ace JY JY16...2T | Front wheel | 90311-68001 | 68*90*10 | PAYEN | NJ 525 | |
| TOYOTA | Toy Ace YY YY5#.61...double | Transmission rear | 90311-38007/93 | 38*65*9 | PAYEN | NJ 593 | |
| TOYOTA | TOYO ACE- PY,RY,YY,JY,LY,BY | Rear Wheel Inner | 90311-75039 | 75*100*13 | MUSASHI | T1144 | '72.7~'85 |
| TOYOTA | TOYO-ACE | Diff Drive Pinion | 90311-39028 | 38*74*11 | MUSASHI | | |
| TOYOTA | TOYO-ACE | Transmission | 90311-25001 | 25*38*7 | MUSASHI | | |
| TOYOTA | Toyota Truck.Bus- DA,FA,FC,DB,FB,D | Rear Wheel Inner | 90310-99011 | 100*154*34 | MUSASHI | T1013 | '69.3~'74.3 |
| TOYOTA | Toyota Truck.Bus- DA,FA,FC,DB,FB,D | Rear Wheel Outer | 90311-48027 | 48*62*9 | MUSASHI | T1081 | '69.3~'74.3 |
| TOYOTA | Toyota Truck.Bus- DA,FA,FC,DB,FB,D | Timing Gear Cover | 90311-25002 | 25*45*11 | MUSASHI | T1004 | '69.3~'77.4 |
| TOYOTA | Toyota Truck.Bus- DA,FA,FC,DB,FB,D | Timing Gear Cover | 90310-25006 | 25*45*11 | MUSASHI | T1004 | '69.3~'77.4 |
| TOYOTA | Toyota Truck.Bus- DA,FA,FC,DB,FB,D | Timing Gear Cover | 90311-45094 | 45*68*12 | MUSASHI | T1077 | '69.3~'80.2 |
| TOYOTA | Toyota Truck.Bus- DA,FA,FC,DB,FB,D | Timing Gear Cover | 90311-65033 | 65*95*14 | MUSASHI | T1097 | '77.4~ |
| TOYOTA | Toyota Truck.Bus- DA,FA,FC,DB,FB,D | Transmission Rear | 90311-55006 | 55*78*12 | MUSASHI | T1090 | '69.3~'73.2 |
| TOYOTA | Truck HV (2-3T) HV HV1#.4# | | 90311-45018 | 45*62*9 | PAYEN | NJ 261 | |
| TOYOTA | Truck, Bus | Transmission | 90311-55008 | 55*78*12 | MUSASHI | | |
| TOYOTA | | Cam Shaft | 90311-35003 | 35*49*6 | MUSASHI | T1173 | '82.1~'85.8 |
| TOYOTA | | Cam Shaft | 90311-35005 | 35*49*6 | MUSASHI | T1173 | '82.8~ |
| TOYOTA | | Ciguenal tras.F10 | 90043-11042 | 60*82*9 | PAYEN | NJ273 | |
| TOYOTA | | Crank Shaft Rear | 90311-99065 | 100*120*11 | MUSASHI | T1014 | '69.3~'85.6 |
| TOYOTA | | Crank Shaft Rear | 90311-99003 | 100*120*11 | MUSASHI | T1014 | '69.3~'85.6 |
| TOYOTA | | Crank Shaft Rear | 90311-99005 | 105*120*11 | MUSASHI | T1217 | '85.6~ |
| TOYOTA | | Crank Shaft Rear | 90311-75004 | 75*100*8.5 | MUSASHI | T1211 | '88.5~'89.10 |
| TOYOTA | | Crank Shaft Rear | 90311-80066 | 80*100*12 | MUSASHI | T1129 | '73.4~'85.12 |
| TOYOTA | | Crank Shaft Rear | 90311-60065 | 80*100*12 | MUSASHI | T1129 | '74.1~'82.10 |
| TOYOTA | | Crank Shaft Rear | 90311-80068 | 80*100*12 | MUSASHI | T1129 | '73.8~'82.10 |
| TOYOTA | | Crank Shaft Rear | 90311-80002 | 80*100*12 | MUSASHI | T1129 | '73.8~'82.10 |
| TOYOTA | | Crank Shaft Rear | 90311-80139 | 80*100*12 | MUSASHI | T1129 | '73.4~'85.12 |
| TOYOTA | | Crank Shaft Rear | 90311-85000 | 85*105*10 | MUSASHI | T1183 | '84.2~ |
| TOYOTA | | Crank Shaft Rear | 90311-88001 | 88*106*8.5 | MUSASHI | | '89.8~ |
| TOYOTA | | Crank Shaft Rear | 90311-95005-000 | 95*115*12 | MUSASHI | T1128 | '72~'89.8 |
| TOYOTA | | Differential Side | 90311-38011 | 38*63*10/17 | MUSASHI | T1065 | '76.12~'88.8 |
| TOYOTA | | Eje transferencia | 90043-16005 | 45*62*11 | PAYEN | NJ669 | |
| TOYOTA | | PUMP TOYOTA HILUX | 90913-14227 | 14.5*22*7 | | | |
| TOYOTA | | Retainer No.2 | 90311-32001 | 32*46*6 | MUSASHI | | '88.9~ |
| TOYOTA | | Retainer No.2 | 90311-42001 | 42*60*9 | MUSASHI | T1127 | '79.12~'82.2 |
| TOYOTA | | Steering Sector | 90311-28014 | 28*40*8 | MUSASHI | T1005 | '74.4~'87 |
| TOYOTA | | Steering Sector | 90310-28014 | 28*40*8 | MUSASHI | T1005 | '70.11~'85 |
| TOYOTA | | Steering Sector | 90311-36004 | 36*46*9 | MUSASHI | | '82.12~'89.7 |
| TOYOTA | | Steering Sector | 90311-36104 | 36*50*7 | MUSASHI | T1130 | '80.8~'84.11 |
| TOYOTA | | Steering Sector | 90311-38033 | 38*52*9 | MUSASHI | | '87.8~ |
| TOYOTA | | Steering Worm | 90311-17092 | 17.4*30*7 | MUSASHI | T1017 | '72.5~'78.7 |
| TOYOTA | | Steering Worm | 90311-18010 | 18*30*8 | MUSASHI | T1139 | '79.10~'88.9 |
| TOYOTA | | Steering Worm | 90311-18001 | 18*30*8 | MUSASHI | T1139 | '79.10~'88.9 |
| TOYOTA | | Timing Gear Case | 90311-42012 | 42*60*7 | MUSASHI | T1178 | '82.2~ |

| CAR | MODEL | APPLICATION | OEM NO. | SIZE | DATA acc. | CODE | YEARS |
|----------------|-------------------------------|--|-------------------|-------------------|-----------|--------|-------------|
| TOYOTA | | Timing Gear Case | 90311-48014 | 48*68*7 | MUSASHI | | '89.6~ |
| TOYOTA | | Timing Gear | 90311-48004 | 48*70*12 | MUSASHI | | '81.8~'84.8 |
| TOYOTA | | | 90313-13001 | 13*20*5 | PAYEN | NJ747 | |
| TOYOTA | | | 90311-13050 | 13*25*7 | PAYEN | NJ741 | |
| TOYOTA | | | 90310-13001 | 13*25*7 | PAYEN | NK013 | |
| TOYOTA | | | 90312-15003 | 15*22*4 | PAYEN | NJ744 | |
| TOYOTA | | | 90311-15002 | 15*25*7 | PAYEN | NJ143 | |
| TOYOTA | | | 90311-16001 | 16*30*7 | PAYEN | NK095 | |
| TOYOTA | | | 90312-17001 | 17*24*5 | PAYEN | NJ745 | |
| TOYOTA | | | | 18*30*7 | PAYEN | NJ963 | |
| TOYOTA | | | 90316-20006 | 20*34*10/15 | PAYEN | NJ204 | |
| TOYOTA | | | 90316-22001 | 22*36*10/15 | PAYEN | NJ205 | |
| TOYOTA | | | 90312-25015 | 25*35*5 | PAYEN | NJ870 | |
| TOYOTA | | | 90310-25006 | 25*45*11 | PAYEN | NJ586 | |
| TOYOTA | | | 90311-25002 | 25*45*11 | PAYEN | NJ586 | |
| TOYOTA | | | 43218-20540-71 | 28*37*6 | | | |
| TOYOTA | | | 90311-35001 | 35*48*7 | PAYEN | NJ743 | |
| TOYOTA | | | 90311-38037 | 38*52*7 | PAYEN | NJ127 | |
| TOYOTA | | | 94840652 | 38*55*8.5 | PAYEN | NJ891 | |
| TOYOTA | | | 90311-38020 | 38*55*8.5 | PAYEN | NJ891 | |
| TOYOTA | | | 90311-61001 | 61*76*7/10 | PAYEN | NJ140 | |
| TOYOTA | | | 90311-85006 | 85*105*10 | PAYEN | NJ215 | |
| TOYOTA | | | 42415-20540-71 | 90*118*12 | | | |
| TOYOTA | B 4 cyl Diesel 2977 cc | Crank Shaft Rear | 90311-95092 | 95*115*12 | PAYEN | NJ240 | 73-85 |
| TOYOTA | CE9# | Front Wheel | 94847441 | 56*73*8/12.5 | PAYEN | NJ868 | 5/87-on |
| TOYOTA | CE9# | Front Wheel | 94846345 | 52*66*7.5/12 | PAYEN | NJ867 | 5/87- on |
| TOYOTA | JY30 | Rear Wheel Inner | 90311-75039 | 75*100*13 | PAYEN | NJ433 | 3/79-85 |
| TOYOTA | LY2#.3# | Transmission | 90311-20004 | 28.6*43*6.5 | PAYEN | NJ439 | 3/79-85 |
| TOYOTA | YN5#.8# | Front Wheel | 90311-50136 | 50*68*9 | PAYEN | NJ069 | 11/83-on |
| TOYOTA | YY50.51 1.25T | Rear Wheel Inner | 90311-50030 | 50*70*9 | PAYEN | NJ070 | 8/85-on |
| TOYOTA | YY50.51 1.25T | Rear Wheel Inner | 90310-50039 | 50*70*9 | PAYEN | NJ070 | 8/85-on |
| TOYOTA | Starlet NP NP7# | Transmission rear | 90311-34007 | 35*54*9/15 | PAYEN | NJ 704 | |
| TOYOTA | HI-LUX 2KD/5L/VIG | FRONT WHEEL SHAFT REAR YEAR 04 UP | | 80*90/96*10/18 | WT | | |
| TOYOTA | HI-LUX 2KD/5L/VIG | FRONT WHEEL SHAFT REAR INNER YEAR 04 UP | | 73*89.5/98*7/15.8 | WT | | |
| TOYOTA | Corona TT TT10#.110.12# | Steering Worm | 90311-17062 | 17.4*30*7 | PAYEN | NJ518 | 12/70-7/77 |
| TOYOTA | Corolla(FWD)- AE,CE,EE | Wheel Hub Rear Outer | | 52*65*7.5/12 | MUSASHI | T1257 | '91.9~'95.5 |
| TOYOTA | | | 90311-24001 | 24*43*8.5 | PAYEN | NK046 | |
| TOYOTA HINO | 2-2XD Truck G (10-12T) GN | Front wheel | 9828-6637-00 | 138*152*12 | PAYEN | NJ 391 | |
| TOYOTA HINO | 2-2XD Truck G (10-12T) GN | Front wheel | 9828-6637-00 | 138*152*12 | PAYEN | NJ 391 | |
| TOYOTA HINO | 2XD-4 Truck K (10-12T) KF | Transmission Front | 1828-5505-00 | 55*72*9 | PAYEN | NJ 461 | |
| TOYOTA HINO | 2XD-D Truck F (10-12T) FS | Rear wheel - inner | 9828-01193/93A/95 | 154*175*13 | PAYEN | NJ 923 | |
| TOYOTA HINO | AC140 | Rear wheel - outer | 9828-40105 | 40*50*6.5 | PAYEN | NK004 | 8/83-on |
| TOYOTA HINO | AC140 | Rear wheel - outer | 9828-40102 | 40*50*6.5 | PAYEN | NK004 | 8/83-on |
| TOYOTA HINO | AC140 | Rear wheel - outer | 9828-40101 | 40*50*6.5 | PAYEN | NK004 | 8/83-on |
| TOYOTA HINO | DM100 6 cyl Diesel 4313 cc | Timing Cover | 1828-5501-00 | 55*72*9 | PAYEN | NJ294 | 64-on |
| TOYOTA HINO | EB100 6 cyl Diesel 9036 cc | Air compressor | 9828-25106 | 25*45*10 | PAYEN | NJ304 | 67-72 |

| CAR | MODEL | APPLICATION | OEM NO. | SIZE | DATA acc. | CODE | YEARS |
|----------------|--|--|------------------|-----------------|-----------|--------|-------------|
| TOYOTA HINO | EC100 6 cyl Diesel 5010 cc | Timing Cover | 9828-58105 | 58*75*9 | PAYEN | NJ297 | 69-71 |
| TOYOTA HINO | EF100 8 cyl Diesel 13804 cc | Crank Shaft Rear | 9828-01158 | 130*161*14 | PAYEN | NJ306 | 72-on |
| TOYOTA HINO | EF700 V8 cyl Diesel 15920 cc | Crank Shaft Rear | 9828-01168 | 135*165*14/20.5 | PAYEN | NJ725 | 7/79-on |
| TOYOTA HINO | EH300 6 cyl Diesel 6211 cc | Crank Shaft Rear | 9828-01144 | 106*126*12 | PAYEN | NJ 303 | |
| TOYOTA HINO | EV700 V10 cyl Diesel 19900 cc | Crank Shaft Rear | 9828-01199 | 135*165*14/20.5 | PAYEN | NJ725 | |
| TOYOTA HINO | FS | Differential Pinion- Front | 1828-9004-00 | 90*115*13/19 | PAYEN | NJ730 | 5/81-on |
| TOYOTA HINO | Hino Bus | Engine Crank Shaft Rear | | 106*126*12 | MUSASHI | H3066 | '74~'83 |
| TOYOTA HINO | Hino Bus | Engine Crank Shaft Rear | | 122*150*12/18 | MUSASHI | | '82.10~'90 |
| TOYOTA HINO | Hino Bus | Engine Crank Shaft Rear | | 125*155*14/23 | MUSASHI | H3088 | '79~ |
| TOYOTA HINO | Hino Bus | Transmission Rear Cover | | 60*75*9/15 | MUSASHI | N3099 | '83.8~'90.9 |
| TOYOTA HINO | Hino Bus- AM,AC,AB,RB,CH,R H,RL,RJ,RR,RC,RE, RS,RV,RT,RU,HT,H | Rear Wheel Outer | 9828-50108 | 60*74*7.5 | MUSASHI | H3012 | '69~'84 |
| TOYOTA HINO | Hino Bus- AM,AC,AB,RB,CH,R H,RL,RJ,RR,RC,RE, RS,RV,RT,RU,HT,H | Rear Wheel Outer | 9828-60109 | 60*74*7.5 | MUSASHI | H3012 | '69~'84 |
| TOYOTA HINO | Hino Bus- HT23#,2M,HU23,2M ...EE Drive | Transmission Fornt Cover | | 55*78*12 | MUSASHI | ※ | '85.8~ |
| TOYOTA HINO | Hino EC100 6 CYL DIESEL 5010 cc | | 2380-1122-00/10 | 58*75*9 | PAYEN | NJ 297 | |
| TOYOTA HINO | Hino EV700 V10 CYL DIESEL 19900 | | 9828-01109/68/99 | 135*165*14/20.5 | PAYEN | NJ 725 | |
| TOYOTA HINO | Hino Truck 10t~12t- Drive System 2 x D- D ZM,FS | Crank Shaft Front | 9828-70102 | 70*95*13 | MUSASHI | H3074 | '71~'83 |
| TOYOTA HINO | Hino Truck 10t~12t- Drive System 2 x D- D ZM,FS | Crank Shaft Front | 9828-70105 | 70*95*13 | MUSASHI | H3074 | '71~'83 |
| TOYOTA HINO | Hino Truck 10t~12t- Drive System 2 x D- D ZM,FS | Crank Shaft Front | 9828-70110 | 70*95*13/20 | MUSASHI | H3089 | '84~ |
| TOYOTA HINO | Hino Truck 10t~12t- Drive System 2 x D- D ZM,FS | Crank Shaft Rear | 9828-01103 | 135*165*14 | MUSASHI | H3076 | ~'81 |
| TOYOTA HINO | Hino Truck 10t~12t- Drive System 2 x D- D ZM,FS | Crank Shaft Rear | 9828-01109 | 135*165*14/20.5 | MUSASHI | H3085 | '81.5~ |
| TOYOTA HINO | Hino Truck 10t~12t- Drive System 2 x D- D ZM,FS | Crank Shaft Rear | 9828-01199 | 135*165*14/20.5 | MUSASHI | H3085 | '81.5~ |
| TOYOTA HINO | Hino Truck 10t~12t- Drive System 2 x D- D ZM,FS | Rear Wheel Inner(Forward & Rearward) | 9828-01195 | 154*175*13 | MUSASHI | H3058 | '81.5~ |
| TOYOTA HINO | Hino Truck 10t~12t- Drive System 2 x D- D ZM,FS | Rear Wheel Inner(Forward & Rearward) | 9828-01193 | 154*175*13 | MUSASHI | H3058 | '81.5~ |

| CAR | MODEL | APPLICATION | OEM NO. | SIZE | DATA acc. | CODE | YEARS |
|----------------|---|--|--------------|--------------|-----------|--------|---------|
| TOYOTA HINO | Hino Truck 10t~12t- Drive System 2 x D- D ZM,FS | Rear Wheel Outer(Forward & Rearward) | 9828-60108 | 60*74*7.5 | MUSASHI | H3012 | '71~'81 |
| TOYOTA HINO | Hino Truck 10t~12t- Drive System 2 x D- D ZM,FS | Rear Wheel Outer(Forward & Rearward) | 9828-60115 | 60*74*7.5 | MUSASHI | H3012 | '71~'81 |
| TOYOTA HINO | Hino Truck 10t~12t- Drive System 2 x D- D ZM,FS | Transmission Front | 9828-55113 | 55*72*9 | MUSASHI | H3073 | '71~ |
| TOYOTA HINO | Hino Truck 10t~12t- Drive System 2 x D- D ZM,FS | Transmission Front | 9828-55113 | 55*72*9 | MUSASHI | H3073 | '71~ |
| TOYOTA HINO | Hino Truck 10t~12t- Drive System 2-2 x D TC,FN,GN | Front Wheel (Forward & Rearward) | 9828-01165 | 138*152*12 | MUSASHI | H3030 | '71~ |
| TOYOTA HINO | Hino Truck 10t~12t- Drive System 2-2 x D TC,FN,GN | Front Wheel (Forward & Rearward) | 9828-01207 | 138*152*12 | MUSASHI | H3030 | '71~ |
| TOYOTA HINO | Hino Truck 10t~12t- Drive System 2-2 x D TC,FN,GN | Front Wheel (Forward & Rearward) | 9828-01125 | 138*152*12 | MUSASHI | H3030 | '71~ |
| TOYOTA HINO | Hino Truck 10t~12t- Drive System 2-2 x D TC,FN,GN | Front Wheel (Forward & Rearward) | 9828-01112 | 138*152*12 | MUSASHI | H3030 | '71~ |
| TOYOTA HINO | Hino Truck 10t~12t- Drive System 2-2 x D TC,FN,GN | Front Wheel (Forward & Rearward) | 9828-01165 | 138*152*12 | MUSASHI | H3030 | '71~ |
| TOYOTA HINO | Hino Truck 10t~12t- Drive System 2-2 x D TC,FN,GN | Front Wheel (Forward & Rearward) | 9828-01207 | 138*152*12 | MUSASHI | H3030 | '71~ |
| TOYOTA HINO | Hino Truck 10t~12t- Drive System 2-2 x D TC,FN,GN | Front Wheel (Forward & Rearward) | 9828-01125 | 138*152*12 | MUSASHI | H3030 | '71~ |
| TOYOTA HINO | Hino Truck 10t~12t- Drive System 2-2 x D TC,FN,GN | Front Wheel (Forward & Rearward) | 9828-01112 | 138*152*12 | MUSASHI | H3030 | '71~ |
| TOYOTA HINO | Hino Truck 6t~8t- KR,FF,FG,FB,FH | Drive Pinion | 9828-65113 | 65*114*10/26 | MUSASHI | | '84~'89 |
| TOYOTA HINO | Hino Truck 6t~8t- KR,FF,FG,FB,FH | Rear Wheel Inner | 9828-01204 | 145*164*14 | MUSASHI | H3083 | '84~ |
| TOYOTA HINO | Hino Truck 6t~8t- KR,FF,FG,FB,FH | Transmission Front | 9828-48102 | 48*60*9 | MUSASHI | | '80~'90 |
| TOYOTA HINO | Hino Truck 6t~8t- KR,FF,FG,FB,FH | Transmission Rear | 9828-50119 | 60*75*9/15 | MUSASHI | | '84~ |
| TOYOTA HINO | Hino Truck 6t~8t- KR,FF,FG,FB,FH | Transmission Rear | 9828-63108 | 63*78*9/15 | MUSASHI | | '89~ |
| TOYOTA HINO | Hino Truck 6t~8t- KR,FF,FG,FB,FH | Transmission Rear | 9828-63108 | 63*78*9/15 | MUSASHI | | '89~ |
| TOYOTA HINO | Hino Truck 6t~8t- KR,FF,FG,FB,FH | Transmission Rear | 9828-65111 | 65*95*14/22 | MUSASHI | | '70~'79 |
| TOYOTA HINO | Hino Truck(2XD-D)- ZM,FS | Wheel Hub Rear Outer(F) | | 60*74*7.5 | MUSASHI | H3012 | '71~'81 |
| TOYOTA HINO | HT.HU | Front Wheel | 9828-01165 | 138*152*12 | PAYEN | NJ391 | 6/82-on |
| TOYOTA HINO | KRAFT | Transmission Front | 9586-45682 | 45*68*12 | MUSASHI | | |
| TOYOTA HINO | KRAFT | Transmission Rear | 9586-40621 | 40*62*12 | MUSASHI | | |
| TOYOTA HINO | LARGE Bus R RC.RE.RS.RT.RU.R | Front wheel | 2301-6637-00 | 138*152*12 | PAYEN | NJ 391 | |

| CAR | MODEL | APPLICATION | OEM NO. | SIZE | DATA acc. | CODE | YEARS |
|----------------|---------------------------------|-----------------------|--------------------|--------------|-----------|--------|-------------|
| TOYOTA HINO | LARGE Bus R RC.RE.RS.RT.RU.R | Front wheel | 2301-6637-00 | 138*152*12 | PAYEN | NJ 391 | |
| TOYOTA HINO | LARGE Bus R RC.RE.RS.RV | Rear wheel - outer | 1828-6008/09-00 | 60*74*7.5 | PAYEN | NJ 421 | |
| TOYOTA HINO | LARGE Bus R RC.RE.RS.RV | Transmission rear | 1828-6502/08/09-00 | 65*95*14/22 | PAYEN | NJ 773 | |
| TOYOTA HINO | Ranger | Front Wheel | 2-301-6637-00 | 138*152*12 | MUSASHI | | |
| TOYOTA HINO | Ranger | Front Wheel | 9826-01165 | 138*152*12 | MUSASHI | | |
| TOYOTA HINO | Ranger | Front Wheel | 2-301-6637-00 | 138*152*12 | MUSASHI | | |
| TOYOTA HINO | Ranger | Rear Wheel Outer | 18284-00100 | 40*50*6.5 | MUSASHI | | |
| TOYOTA HINO | Ranger | Timing Cover | 1-828-5505-00 | 55*72*9 | MUSASHI | | |
| TOYOTA HINO | Ranger 2 . 3 2t~3t- HV | Crank Shaft Rear | 90040-11076 | 95*110*11 | MUSASHI | D4735 | '78.8~'84 |
| TOYOTA HINO | Ranger 2 . 3 2t~3t- HV | Crank Shaft Rear | 9031B-95095 | 95*115*12 | MUSASHI | T1128 | '78.8~'84.9 |
| TOYOTA HINO | Ranger 2 . 3 2t~3t- HV | Crank Shaft Rear | 9031B-95091 | 95*115*12 | MUSASHI | T1128 | '78.8~'84.9 |
| TOYOTA HINO | Ranger 2 . 3 2t~3t- HV | Crank Shaft Rear | 9031B-95001 | 95*115*12 | MUSASHI | T1128 | '78.8~'84.9 |
| TOYOTA HINO | Ranger 2 . 3 2t~3t- HV | Crank Shaft Rear | 90311-95095 | 95*115*12 | MUSASHI | T1128 | '78.8~'84.9 |
| TOYOTA HINO | Ranger 2 . 3 2t~3t- HV | Crank Shaft Rear | 90311-95003 | 95*115*12 | MUSASHI | T1128 | '78.8~'84.9 |
| TOYOTA HINO | Ranger 2 . 3 2t~3t- HV | Crank Shaft Rear | 90311-95001 | 95*115*12 | MUSASHI | T1128 | '78.8~'84.9 |
| TOYOTA HINO | Ranger 2 . 3 2t~3t- HV | Drive Pinion | 90040-11059 | 50*82*12 | MUSASHI | D4728 | '78~'84.9 |
| TOYOTA HINO | Ranger 2 . 3 2t~3t- HV | Front Wheel | 90040-11102 | 68*88*10 | MUSASHI | D4708 | '78~ |
| TOYOTA HINO | Ranger 2 . 3 2t~3t- HV | Rear Wheel Inner | 90040-11053 | 70*112*14/20 | MUSASHI | D4700 | '78~ |
| TOYOTA HINO | Ranger 2 . 3 2t~3t- HV | Rear Wheel Outer | 90040-12023 | 55*101*4.7 | MUSASHI | D4729 | '82.3~ |
| TOYOTA HINO | Ranger 2 . 3 2t~3t- HV | Timing Cover | 90311-50007-000 | 50*72*12 | MUSASHI | T1132 | '72~'84.9 |
| TOYOTA HINO | Ranger 2 . 3 2t~3t- HV | Timing Cover | 90311-50049 | 50*72*12 | MUSASHI | T1132 | '78.8~'87 |
| TOYOTA HINO | Ranger 2 . 3 2t~3t- HV | Timing Cover | 9031B-50007 | 50*72*12 | MUSASHI | T1132 | '78.8~'87 |
| TOYOTA HINO | Ranger 2 . 3 2t~3t- HV | Timing Cover | 9031B-50049 | 50*72*12 | MUSASHI | T1132 | '78.8~'87 |
| TOYOTA HINO | Ranger 2 . 3 2t~3t- HV | Timing Cover | 90311-50007 | 50*72*12 | MUSASHI | T1132 | '78.8~'87 |
| TOYOTA HINO | Ranger 2 . 3 2t~3t- HV | Transmission Front | 9031B-28004 | 28.6*43*6.5 | MUSASHI | T1044 | '78.8~'84 |
| TOYOTA HINO | Ranger 2 . 3 2t~3t- HV | Transmission Front | 90311-28004 | 28.6*43*6.5 | MUSASHI | T1044 | '78.8~'84 |
| TOYOTA HINO | Ranger 2 . 3 2t~3t- HV | Transmission Front | 90311-32106 | 32*48*8 | MUSASHI | T1054 | '78.8~'85.8 |
| TOYOTA HINO | Ranger 2 . 3 2t~3t- HV | Transmission Front | 9031B-32012 | 32*53*7 | MUSASHI | T1193 | '85.8~ |
| TOYOTA HINO | Ranger 2 . 3 2t~3t- HV | Transmission Rear | 9031B-45001 | 45*62*9 | MUSASHI | T1076 | '78.8~'85.8 |
| TOYOTA HINO | Ranger 2 . 3 2t~3t- HV | Transmission Rear | 90311-45001 | 45*62*9 | MUSASHI | T1076 | '78.8~'85.8 |

| CAR | MODEL | APPLICATION | OEM NO. | SIZE | DATA acc. | CODE | YEARS |
|----------------|-------------------------------------|-------------------------|------------------|---------------|-----------|-------|-------------|
| TOYOTA HINO | Ranger 2 . 3 2t~3t- HV | Transmission Rear | 90040-11100 | 45*62*9 | MUSASHI | D4716 | '78.8~'84 |
| TOYOTA HINO | Ranger 2 . 3 2t~3t- HV | Transmission Rear | 9031B-45001 | 45*62*9 | MUSASHI | T1076 | '78.8~'85.8 |
| TOYOTA HINO | Ranger 2 . 3 2t~3t- HV | Transmission Rear | 90311-45001 | 45*62*9 | MUSASHI | T1076 | '78.8~'85.8 |
| TOYOTA HINO | Ranger 3.5t~5t | Crank Shaft Rear | 9828-00109 | 100*120*13/18 | PAYEN | NJ922 | |
| TOYOTA HINO | Ranger 3.5t-KM,FB | Crank Shaft Front | 9828-55105 | 55*72*9 | MUSASHI | H3010 | '71~'83 |
| TOYOTA HINO | Ranger 3.5t-KM,FB | Crank Shaft Front | 9828-55101 | 55*72*9 | MUSASHI | H3010 | '71~'83 |
| TOYOTA HINO | Ranger 3.5t-KM,FB | Crank Shaft Front | 9828-58104 | 58*75*9/14.5 | MUSASHI | | '83~ |
| TOYOTA HINO | Ranger 3.5t-KM,FB | Crank Shaft Front | 9828-58104 | 58*75*9/14.5 | PAYEN | NJ929 | |
| TOYOTA HINO | Ranger 3.5t-KM,FB | Drive Pinion | 9828-58109 | 58*102*8/22 | MUSASHI | | '84.7~ |
| TOYOTA HINO | Ranger 3.5t-KM,FB | Rear Wheel Outer | 9828-40102 | 40*50*6.5 | MUSASHI | H3003 | '65~'86 |
| TOYOTA HINO | Ranger 3.5t-KM,FB | Rear Wheel Outer | 9828-40101 | 40*50*6.5 | MUSASHI | H3003 | '65~'86 |
| TOYOTA HINO | Ranger 4.5t~5t-- FT3H...EAL,GAL | Wheel Hub Front | | 140*160*12 | MUSASHI | ※ | '90.3~ |
| TOYOTA HINO | Ranger 4.5t~5t- KL,FC,FD,GD,FT,F | Wheel Hub Rear Inner | | 122*138*12 | MUSASHI | H3092 | '80~'94 |
| TOYOTA HINO | Ranger 4t~5.5t- KL,FC,FD,GD | Rear Wheel Inner | 9828-01203 | 127*147*11 | MUSASHI | H3079 | '84~ |
| TOYOTA HINO | Ranger 4t~5.5t- KL,FC,FD,GD | Rear Wheel Outer | 9828-57102 | 57*124*13 | MUSASHI | H3078 | '84~ |
| TOYOTA HINO | Ranger 4t~5.5t- KL,FC,FD,GD | Rear Wheel Outer | 9828-57103 | 57*124*13 | MUSASHI | H3078 | '84~ |
| TOYOTA HINO | Ranger 4t~5.5t- KL,FC,FD,GD | Transmission Front | 9828-37013 | 37*50*6 | MUSASHI | | '80~'83 |
| TOYOTA HINO | Ranger 4t~5.5t- KL,FC,FD,GD | Transmission Front | 9828-37013 | 37*50*6.2 | MUSASHI | | '80~'83 |
| TOYOTA HINO | Ranger 4t~5.5t- KL,FC,FD,GD | Transmission Front | 9828-46102 | 48*60*9 | MUSASHI | | '86~'89 |
| TOYOTA HINO | Ranger 4t~5.5t- KL,FC,FD,GD | Transmission Rear | 9828-60119 | 60*75*9/15 | MUSASHI | | '83~'84 |
| TOYOTA HINO | RC.RE.RS.RV | Rear wheel - inner | 9828-01110 | 146*170*18 | PAYEN | NJ422 | 69-on |
| TOYOTA HINO | RC.RE.RS.RV | Rear-Wheel-Outer | 9828-60108/09/15 | 60*74*7.5 | PAYEN | NJ421 | 71-81 |
| TOYOTA HINO | RC.RE.RS.RV | Transmission Feont | 9828-55105 | 55*72*9 | PAYEN | NJ461 | 69-on |
| TOYOTA HINO | RC.RE.RS.RV | Transmission Feont | 9828-55113 | 55*72*9 | PAYEN | NJ461 | 69-on |
| TOYOTA HINO | RC.RE.RS.RV | Transmission Feont | 9828-55101 | 55*72*9 | PAYEN | NJ461 | 69-on |
| TOYOTA HINO | RC.RE.RS.RV | Transmission Rear | 9828-65109 | 65*95*14/22 | PAYEN | NJ773 | |
| TOYOTA HINO | RC.RE.RS.RV | Transmission Rear | 9828-65107 | 65*95*14/22 | PAYEN | NJ773 | 69-79 |
| TOYOTA HINO | RC.RE.RS.RV | Transmission Rear | 1828-6509-00 | 65*95*14/22 | PAYEN | NJ773 | 69-79 |
| TOYOTA HINO | RC.RE.RS.RV | Transmission Rear | 9828-65108 | 65*95*14/22 | PAYEN | NJ773 | 69-79 |
| TOYOTA HINO | Truck | Rear Wheel Outer | 1-828-6008-00 | 60*74*7.5 | MUSASHI | | |

| CAR | MODEL | APPLICATION | OEM NO. | SIZE | DATA acc. | CODE | YEARS |
|----------------|--|----------------------|--------------------|---------------|-----------|--------|---------|
| TOYOTA HINO | Truck | Rear Wheel Outer | 1-828-6009-00 | 60*74*7.5 | MUSASHI | | |
| TOYOTA HINO | Truck | Rear Wheel Outer | 1-828-6003-00 | 60*74*7.5 | MUSASHI | | |
| TOYOTA HINO | Truck | Timing Cover | 1-828-8001-00 | 80*105*13 | MUSASHI | | |
| TOYOTA HINO | Truck F (3.5-5T) FB | Rear wheel - inner | 9828-01206 | 106*123*11 | PAYEN | NJ 925 | |
| TOYOTA HINO | Truck F (3.5-5T) FD | | 9828-01203 | 127*147*11 | PAYEN | NK 020 | |
| TOYOTA HINO | Truck F (3.5-5T) FD | | 9828-65113 | 65*114*10/26 | PAYEN | NJ 914 | |
| TOYOTA HINO | Truck F (3.5-5T) FD16#...TURBO | | 9828-48102 | 48*60*9 | PAYEN | NJ 772 | |
| TOYOTA HINO | Truck F (3.5-5T) FD16#.3W...6 | Transmission-rear | 9828-60119 | 60*75*9/15 | PAYEN | NJ 673 | |
| TOYOTA HINO | Truck G (3.5-5T) GD | Front Wheel | 2445-6623/24-00 | 101*114*10 | PAYEN | NJ 420 | |
| TOYOTA HINO | Truck G (3.5-5T) GD | Rear wheel - inner | 2445-6804-00/10/20 | 120*140*12 | PAYEN | NJ 582 | |
| TOYOTA HINO | Truck HV (2-3T) ALL | Front wheel | Daihatsu 90043-111 | 68*88*10 | PAYEN | NJ 390 | |
| TOYOTA HINO | Truck HV (2-3T) ALL | Rear wheel - inner | Daihatsu 90043-110 | 70*112*14/20 | PAYEN | NJ 385 | |
| TOYOTA HINO | Truck HV (2-3T) ALL | Rear wheel - outer | Daihatsu 90043-120 | 55*101*4.7 | PAYEN | NJ 668 | |
| TOYOTA HINO | Truck HV (2-3T) EXCEPT HV25L.15L.15W | Differential Pinion | Daihatsu 90043-110 | 50*82*12 | PAYEN | NJ 647 | |
| TOYOTA HINO | Truck HV (2-3T) HV100D.17.18.4# | | 90311-28004 | 28.6*43*6.5 | PAYEN | NJ 439 | |
| TOYOTA HINO | Truck HV (2- 3T)HV2# | Transmission front | Daihatsu 90043-111 | 30*45*8 | PAYEN | NJ 454 | |
| TOYOTA HINO | Truck K (3.5-5T) KM | Rear wheel - outer | 1828-4001/02-00 | 40*50*6.5 | PAYEN | NK 004 | |
| TOYOTA HINO | Truck K (6-8T) KR305.325.365 | Transmission front | 9828-37103 | 37*50*6 | PAYEN | NJ 770 | |
| TOYOTA HINO | Truck.Bus | Timing Cover | 1-282-8001-00 | 80*105*13 | MUSASHI | | |
| TOYOTA HINO | Truck.Bus | Transmission Rear | 91-828-6509-00 | 65*95*14/22 | MUSASHI | | |
| TOYOTA HINO | | Crank Shaft Front | 9828-65119 | 65*88*12/19 | MUSASHI | H3077 | '78~'83 |
| TOYOTA HINO | | Crank Shaft Front | 9828-65116 | 65*88*12/19 | MUSASHI | H3077 | '78~'83 |
| TOYOTA HINO | | Crank Shaft Rear | 9828-00109 | 100*120*13/18 | MUSASHI | | '83~ |
| TOYOTA HINO | | Crank Shaft Rear | 9828-01144 | 106*126*12 | MUSASHI | H3066 | '74~'83 |
| TOYOTA HINO | | Crank Shaft Rear | 9828-01167 | 106*126*12 | MUSASHI | H3066 | '74~'83 |
| TOYOTA HINO | | Crank Shaft Rear | 9828-01194 | 122*150*12/18 | MUSASHI | | '82~ |
| TOYOTA HINO | | | 9828-01166 | 125*155*14/23 | PAYEN | NJ375 | |
| TOYOTA HINO | | | 9828-01134 | 140*160*12 | PAYEN | NK070 | |
| TOYOTA HINO | | | 9828-27102 | 27*40*8 | PAYEN | NK086 | |
| TOYOTA HINO | | | 9828-01985 | 35*57*10 | PAYEN | NJ713 | |

| CAR | MODEL | APPLICATION | OEM NO. | SIZE | DATA acc. | CODE | YEARS |
|-------------|--|----------------------|---------------------|---------------|-----------|--------|--------------|
| TOYOTA HINO | | | 9828-65112A | 65*80*10/17 | PAYEN | NK017 | |
| TOYOTA HINO | | | | 70*95*13/20 | PAYEN | NJ724 | |
| TOYOTA HINO | | | 9828-80110A | 80*136*10/26 | | | |
| TOYOTA HINO | FC | Front Wheel | 9828-01137/47 | 101*114*10 | PAYEN | NJ420 | 6/84-on |
| TOYOTA HINO | FD | Rear Wheel-Inner | 9828-01104/48/49/84 | 120*140*12 | PAYEN | NJ582 | 2/80-83 |
| TOYOTA HINO | Hino Bus-AM,AC,AB,RB,CH,RH,RL,RJ,RR,RC,RE,RS,RV,RT,RU,HT,H | Rear Wheel Outer | 9828-57102 | 57*124*13 | MUSASHI | H3078 | '84~ |
| TOYOTA HINO | Hino Bus-AM,AC,AB,RB,CH,RH,RL,RJ,RR,RC,RE,RS,RV,RT,RU,HT,H | Rear Wheel Outer | 9828-57103 | 57*124*13 | MUSASHI | H3078 | '84~ |
| TOYOTA HINO | RJ170.172.RR170.172 | Rear wheel - outer | 9828-57102 | 57*124*13 | PAYEN | NK021 | 84-on |
| TOYOTA HINO | RJ170.172.RR170.172 | Rear wheel - outer | 9828-57103 | 57*124*13 | PAYEN | NK021 | 84-on |
| TOYOTA HINO | EB300 6 cyl Diesel 9838 cc | Air compressor | 9828-25106 | 25*45*10 | PAYEN | NJ304 | 67-78 |
| TOYOTA HINO | Ranger 2 . 3 2t~3t- | Transmission | 9031B-32106 | 34*48*8 | MUSASHI | T1054 | '78.8~'85.8 |
| TOYOTA HINO | Truck | Crank Shaft | 9828-01102 | 125*155*14 | MUSASHI | H3040 | '75~ |
| TOYOTA | 2E 4 cyl (ohc) 1295 cc | Timing Cover | 90311-35022 | 35*49*6 | PAYEN | NJ353 | 10/84-5/86 |
| TOYOTA | 2K 4 cyl (ohv) 993 | Crank Shaft Rear | 90311-70007 | 70*92*8.5 | PAYEN | NJ001 | 4/69-79 |
| TOYOTA | 2L 4 cyl Diesel 2446 cc | Timing Cover | 90311-42026 | 42*60*7 | PAYEN | NJ344 | 8/83-1/85 |
| TOYOTA | 2L 4 cyl Diesel 2446 cc | Timing Cover | 90311-42019 | 42*60*7 | PAYEN | NJ344 | 8/83-1/85 |
| TOYOTA | 2L 4 cyl Diesel 2446 cc | Timing Cover | 90311-42015 | 42*60*7 | PAYEN | NJ344 | 8/83-1/85 |
| TOYOTA | 3K 4 cyl (ohv) 1166 | Crank Shaft Rear | 90311-70120 | 70*92*8.5 | PAYEN | NJ001 | 73-79 |
| TOYOTA | 5R 4 cyl (ohv) 1994 | Crank Shaft Rear | 90311-80139 | 80*100*12 | PAYEN | NJ030 | 71-77 |
| TOYOTA | 5S 4 cyl (dohc) 2164 cc | Cam Shaft | 90311-38046 | 38*50*8 | PAYEN | NJ347 | 90-91 |
| TOYOTA | 8R 4 cyl (ohc) 1858 cc | Crank Shaft Rear | 90311-90139 | 80*100*12 | PAYEN | NJ030 | 66-76 |
| TOYOTA | 4K 4 cyl (ohv) 1290 | Crank Shaft Rear | 94840023 | 70*92*8.5 | PAYEN | NJ001 | 10/77-2/79 |
| TOYOTA | | | 90311-65003 | 65*79*7 | | | |
| TOYOTA | | | 90311-68002 | 68*92*10 | | | |
| TOYOTA | | | 90311-70011 | 70*94*8/10.5 | | | |
| TOYOTA | | | 90311-22346 | 22*34*6 | | | |
| TOYOTA | | | 90311-22347 | 22*34*7 | | | |
| TOYOTA | Publica-UP,KP | Steering Worm | 90310-30035 | 30*40*7 | MUSASHI | T1140 | '72.1~'78.7 |
| TOYOTA | Publica-UP,KP | Transmission | 90310-20026 | 20*30*7 | PAYEN | NJ901 | '69.4~'71.12 |
| TOYOTA | STARLET (FWD) 2E#...EP7# | Engine OIL PUMP | 90029-21005 | 18*30*8 | MUSASHI | T1291 | 88.8~90. |
| TOYOTA | Carina 3A 4 CYL (OHC) 1453 cc | Timing Cover | 90311-32001/18 | 32.5*46*6 | PAYEN | NJ 349 | |
| TOYOTA | SUPRA GA70,MA70,JZA70, | Wheel Hub REAR OUTER | 90311-57001 | 57*81*8/11 | MUSASHI | T1208 | 86.2~ |
| SUBARU | ALCYONE . Subaru XT-AX | Cam Shaft | 8067-38040 | 38*55*9 | MUSASHI | N2031 | '85.6~ |
| SUBARU | ALCYONE . Subaru XT-AX | Cam Shaft | 13510-H1010 | 38*55*9 | MUSASHI | N2031 | '85.6~ |
| SUBARU | ALCYONE . Subaru XT-AX | Differential (Rear) | 8067-32030 | 32*52*11/15.5 | MUSASHI | N2087 | '85.6~ |

| CAR | MODEL | APPLICATION | OEM NO. | SIZE | DATA acc. | CODE | YEARS |
|--------|--|---------------------------|-------------|---------------|-----------|--------|--------------|
| SUBARU | ALCYONE . Subaru XT-AX | Differential (Rear) | 38342-21000 | 32*52*11/15.5 | MUSASHI | N2087 | '85.6~ |
| SUBARU | ALCYONE . Subaru XT-AX | Drive Pinion | 8067-35130 | 35*67*12/18 | MUSASHI | N2084 | '85.6~ |
| SUBARU | ALCYONE . Subaru XT-AX | Front Wheel Inner | 90625-0018 | 58*76*8/16 | MUSASHI | S4876 | '85.6~ |
| SUBARU | ALCYONE . Subaru XT-AX | Front Wheel Outer | 90625-0015 | 52*72*7.5/16 | MUSASHI | S4870 | '85.6~ |
| SUBARU | ALCYONE . Subaru XT-AX | Rear Wheel | 6230-02020 | 57*67*7 | MUSASHI | S4873 | '85.6~ |
| SUBARU | ALCYONE . Subaru XT-AX | Rear Wheel (Inner) | 0624-40528 | 40*52*8 | MUSASHI | S4872 | '85.6~ |
| SUBARU | DOMINGO E10,12- | Crank Shaft Rear | 8067-60010 | 60*77*10 | MUSASHI | | '83.10~'85.6 |
| SUBARU | DOMINGO E10,12- | Differential | 8057-27040 | 27*45*9 | MUSASHI | S6514 | '83.10~ |
| SUBARU | DOMINGO E10,12-KJ | Transmission Input Shaft | 8057-19010 | 20*35*7 | MUSASHI | S6505 | '83.10~ |
| SUBARU | JUSTY . J10,12-KA | Crank Shaft Rear | 8067-68010 | 68*84*8.5 | MUSASHI | | '85.7~ |
| SUBARU | JUSTY . J10,12-KA | Cylinder Head | 8067-38100 | 38.5*53*8 | MUSASHI | | '84.2~ |
| SUBARU | Justy J10,12---KA | Wheel Hub Front Inner | 7230-34000 | 50*67*9/13 | MUSASHI | S6509 | '84.2~'94 |
| SUBARU | JUSTY KA | Rear wheel | 06243-8558 | 38*55*8 | PAYEN | NJ 096 | |
| SUBARU | JUSTY KA | Rear wheel inner | 90639-0005 | 37*62*10/12 | PAYEN | NJ 208 | |
| SUBARU | JUSTY KA KA...MT | Transmission | 80671-9010 | 20*35*7 | PAYEN | NJ 960 | |
| SUBARU | Legacy BC,BF | Drive Pinion | 38332-21100 | 35*67*12/18 | MUSASHI | N2084 | '89.2~ |
| SUBARU | Legacy BC,BF | Extention Case | 32136-U0100 | 35*50*11 | MUSASHI | N2045 | '89.2~ |
| SUBARU | Legacy BC,BF | Extention Case | 8067-35070 | 35*50*11 | MUSASHI | N2045 | '89.2~ |
| SUBARU | Legacy BC,BF | Front Wheel | 28015-AA021 | 56*72.3*8/12 | MUSASHI | | '89.2~ |
| SUBARU | Legacy BC,BF,BD,BG | Wheel Hub Front Inner | | 56*72.3*8/12 | MUSASHI | S4881 | '89.2~'93.10 |
| SUBARU | Legacy BC,BF,BD,BG | Wheel Hub Rear Inner No.2 | 28015-AA011 | 50*67*5.5/7.5 | MUSASHI | S4883 | '89.2~ |
| SUBARU | Legacy | Engine Oil Pump | | 33*49*8 | MUSASHI | S4888 | '89.2~ |
| SUBARU | Leone - Subaru 1600,1800-A32,A33,AA,AB,AF,AG,AJ,AL,AM,AP | Crank Shaft Rear | 8067-70013 | 70*87*8.5 | MUSASHI | S4878 | '75~ |
| SUBARU | Leone - Subaru 1600,1800-A32,A33,AA,AB,AF,AG,AJ,AL,AM,AP | Crank Shaft Rear | 8067-70012 | 70*87*8.5 | MUSASHI | S4878 | '75~ |
| SUBARU | Leone - Subaru 1600,1800-A32,A33,AA,AB,AF,AG,AJ,AL,AM,AP | Differential (Front) | 8067-27040 | 27*45*9 | MUSASHI | S6514 | '75~'84.6 |
| SUBARU | Leone - Subaru 1600,1800-A32,A33,AA,AB,AF,AG,AJ,AL,AM,AP | Differential (Front) | 8067-27030 | 27*45*9 | MUSASHI | S6514 | '75~'84.6 |
| SUBARU | REX . M80-K23,K24,K43,K44,KKF,KM,KG,KN,KH,K | Front Wheel | 0624-30508 | 30*50*8 | MUSASHI | S6500 | '77.4~'81 |
| SUBARU | REX . M80-K23,K24,K43,K44,KKF,KM,KG,KN,KH,K | Front Wheel (Inner) | 7230-34000 | 50*67*9/13 | MUSASHI | S6509 | '81.9~'89.6 |
| SUBARU | REX . M80-K23,K24,K43,K44,KKF,KM,KG,KN,KH,K | Front Wheel (Inner) | 7230-34040 | 50*67*9/13 | MUSASHI | S6509 | '81.9~'89.6 |
| SUBARU | REX . M80-K23,K24,K43,K44,KKF,KM,KG,KN,KH,K | Rear Wheel | 7230-34010 | 32*52*7 | MUSASHI | S6510 | '81.9~'88 |

| CAR | MODEL | APPLICATION | OEM NO. | SIZE | DATA acc. | CODE | YEARS |
|--------|--|---|-------------------|---------------|-----------|--------|--------------|
| SUBARU | REX-E22,E23,EK23 | Engine Crank Shaft Rear | | 57*77*10 | MUSASHI | S6515 | '76.4~'89 |
| SUBARU | REX-E22,E23....K23,24,K43,K44,KF,KM | Engine Crank Shaft Front | | 30*46*8 | MUSASHI | S6518 | '76.4~'86 |
| SUBARU | REX-K23,K43 | Transmission & Differential Input Shaft | | 17*35*7 | MUSASHI | S6513 | '76.4~'77.3 |
| SUBARU | Sambar-K75,76,77,85,87,KB,KT | Front Wheel | 0624-38558 | 38*55*8 | MUSASHI | S6504 | '76~'90 |
| SUBARU | Subaru A A...2WD | Rear wheel | 62300-2020 | 57*67*6 | PAYEN | NJ 580 | |
| SUBARU | Subaru A A...4WD | Rear wheel outer | 62102-8060 | 50*62*7 | PAYEN | NJ 578 | |
| SUBARU | Subaru A ALL | Front Wheel | 90625-0018 | 58*76*7.8/16 | PAYEN | NJ 848 | |
| SUBARU | Subaru B# BC.BF | Front wheel outer | 90625-0020 | 56*72.3*8 | PAYEN | NJ 990 | |
| SUBARU | Subaru B# BC.BF...4WD | Differential pinion | 80673-5130 | 35*67*12/18 | PAYEN | NJ 575 | |
| SUBARU | Subaru B# BC.BF...4WD | Extention case | 80673-5070 | 35*50*11 | PAYEN | NJ 080 | |
| SUBARU | Subaru B# BC.BF...4WD | Rear wheel inner | 62102-8090 | 50*62*7 | PAYEN | NJ 578 | |
| SUBARU | Subaru EA61 4 CYL (OHV) 1088 cc | Timing Cover | 80673-8040 | 38*55*9 | PAYEN | NJ 022 | |
| SUBARU | Subaru EA61 4 YCL (OHV) 1088 cc | Crank Shaft Rear | 80677-0011/12/13 | 70*87*8.5 | PAYEN | NJ 342 | |
| SUBARU | VAN EF10 3 CYL (OHC) 993 cc | Cam Shaft | 80673-8100 | 38.5*53*8 | PAYEN | NJ 846 | |
| SUBARU | VAN EF10 3 CYL (OHC) 993 cc | Oil Pump | 80672-3010/11 | 23*40*7 | PAYEN | NJ 339 | |
| SUBARU | VAN EK23 2 CYL (OHC) 544 cc | Crank Shaft Rear | 80675-7013 | 57*77*10 | PAYEN | NJ 376 | |
| SUBARU | VAN EK23 2 CYL (OHC) 544 cc | Timing Cover | 80673-0020/21 | 30*46*7 | PAYEN | NJ 252 | |
| SUBARU | | | 80673-0110 | 29*45*8 | PAYEN | NJ313 | |
| SUBARU | A 4WD | Rear Wheel Inner | 06244-0528 | 40*52*8 | PAYEN | NJ577 | 75-on |
| SUBARU | Legacy BC,BF | Rear Wheel Outer | 28015-AA001 | 50*65.3*8 | MUSASHI | S4888 | '89.2~ |
| SUBARU | Front wheel outer | Front wheel outer | 90625-0020 | 56*72.3*8 | PAYEN | NJ 990 | 2/89- on |
| SUBARU | Legacy BC,BF | Rear Wheel Inner(2) | 28015-AA011 | 50*67*5.5/7.5 | MUSASHI | | '89.2~ |
| SUBARU | Subaru B# BC.BF | Front Wheel (Outer) | 90625-0020 | 56*72.3*8/12 | PAYEN | NJ 990 | |
| SUBARU | DOMINGO / E10, E12 KJ5 (2WD) | Wheel Hub FRONT | 62 438 558 | 38*55*8 | MUSASHI | S6504 | 83.10~94. |
| SUBARU | Subaru A A...2WD | Rear wheel | 62300-2020 | 57*67*6 | PAYEN | NJ 580 | 75-ON |
| Suzuki | ALTO C CC71V.72V | Rear wheel | 09283-42008 | 42*55*7 | PAYEN | NJ 052 | |
| Suzuki | ALTO F5A 4 CYL (OHC) 543 cc | Crank Shaft Rear | 09283-60003/05 | 60*80*8 | PAYEN | NJ 337 | |
| Suzuki | ALTO S SS30V | Differential | 09283-35013/22/31 | 35*72*7.5/9.5 | PAYEN | NJ 851 | |
| Suzuki | ALTO-SS,CA,CC,CL,CM,C R,CS,HA,HB,HC,HD | Transmission & Differential Diff Side (LH.RH) | | 30*52*8 | MUSASHI | Z6130 | '88.9~'94.11 |
| Suzuki | ALTO-SS,CA,CC,CL,CM,C R,CS,HA,HB,HC,HD | Transmission & Differential Diff Side (LH.RH) | | 35*52*8 | MUSASHI | Z6136 | '88.9~'94.11 |
| Suzuki | ALTO-SS,CA,CC,CL,CM,C R,CS,HA,HB,HC,HD | Wheel Hub Rear | 9S9V3-42008 | 42*55*7 | MUSASHI | Z6131 | '91.9~'94.11 |
| Suzuki | ALTO-SS,CA,CL,CM,CN,C | Cam Shaft | 90283-32022 | 32*47*8 | MUSASHI | Z6117 | '79.5~'90.3 |
| Suzuki | ALTO-SS,CA,CL,CM,CN,C | Cam Shaft | 09283-35040 | 35*47*6 | MUSASHI | | '90.3~ |
| Suzuki | ALTO-SS,CA,CL,CM,CN,C | Crank Shaft Front | 09283-32026 | 32*47*6 | MUSASHI | Z6125 | '84.9~'90.3 |

| CAR | MODEL | APPLICATION | OEM NO. | SIZE | DATA acc. | CODE | YEARS |
|--------|--|----------------------------|--------------------|---------------|-----------|--------|-------------|
| Suzuki | ALTO-SS,CA,CL,CM,CN,C | Crank Shaft Rear | 09283-60005 | 60*80*8 | MUSASHI | Z6119 | '79.5~'90.3 |
| Suzuki | ALTO-SS,CA,CL,CM,CN,C | Transmission Input Shaft | 24151-73B00 | 20*35*5.5 | MUSASHI | Z6129 | '88.9~'90.3 |
| Suzuki | B120 | KICK SHAFT | 9285-016002 | 16*30*8 | | | |
| Suzuki | Carry D DA41.71.81.DB.41.7 | Differential pinion | 09283-28010 | 28*47*10 | PAYEN | NJ 759 | |
| Suzuki | Carry D DA51.DB51...turbo | | 09283-35008 | 35*62*10/16.5 | PAYEN | NJ 740 | |
| Suzuki | Carry ST ST30.31.40.41 | Transmission rear | 24780-79001 | 28*38*10/15 | PAYEN | NJ 855 | |
| Suzuki | Carry-DD,DF (4WD) | Wheel Hub Front Inner | | 50*68*7/9 | MUSASHI | Z6134 | '91.9~ |
| Suzuki | Carry-F6A(4 Valve)....DA51,DB51,DC,DD,DE,DF | Engine Cam Shaft | | 35*47*6 | MUSASHI | Z6135 | '90.3~ |
| Suzuki | Carry-ST,DA,DB | Drive Pinion | 09283-28010 | 28*47*10 | MUSASHI | Z6107 | '79.4~'90.3 |
| Suzuki | Carry-ST,DA,DB | Drive Pinion | 09283-35008 | 35*62*10/16.5 | MUSASHI | | '90.3~ |
| Suzuki | Cervo SS.CG.CH | Crank Shaft Rear | 09283-50005 | 60*80*8 | MUSASHI | Z6119 | '82.5~'88.1 |
| Suzuki | Cervo SS.CG.CH | Transmission Input Shaft | 09283-20024 | 25*35*7 | MUSASHI | Z6101 | '82.5~'88.1 |
| Suzuki | CUL TUS A AA33.43.53.AB33.43.53 | Front wheel outer | 09283-53001 | 53*68.2*7 | PAYEN | NJ 912 | |
| Suzuki | CUL TUS A AA33.43.53.AB33.43.53 | Front wheel outer | 09283-53001 | 53*68.2*7 | PAYEN | NJ 912 | |
| Suzuki | CUL TUS A AA41.AB41 | Transmission Front | 09283-20040 | 20*35*5.5 | PAYEN | NJ 758 | |
| Suzuki | ESCUDO.VITARA JLX-TA,TD | Wheel Hub Front Outer No.1 | | 54*69*7.5/9.5 | MUSASHI | Z6137 | '88.5~ |
| Suzuki | FRONTE-CB71S,72S,CD72S | Wheel Hub Front | | 44*62*8/14 | MUSASHI | Z6120 | '84.9~'88 |
| Suzuki | FRONTE-SS,CB,CN,CP | Front Wheel | 09283-44008 | 44*62*8/14 | MUSASHI | Z6120 | '84.9~'89 |
| Suzuki | FRONTE-SS,CB,CN,CP | Rear Wheel | 09283-42008 | 42*55*7 | MUSASHI | Z6104 | '88.9~'89 |
| Suzuki | GP100 | PUSH ROD | 09285-06006 | 6*19*7 | | | |
| Suzuki | JEEP & Pick up F5A 3 CYL (OHC) 543 | Cam Shaft | 09283-32002/03/16/ | 32*47*8 | PAYEN | NJ 336 | |
| Suzuki | JEEP & Pick up G13B 4 CYL (DOHC) 1298 cc | Timing Cover | 09283-32026/36 | 32*47*6 | PAYEN | NJ 377 | |
| Suzuki | JEEP JA | Front wheel | 09283-50001/02 | 50*68*7/9 | PAYEN | NJ 701 | |
| Suzuki | JEEP JA | Rear wheel | 09283-48007 | 48*62*9 | PAYEN | NJ 562 | |
| Suzuki | JIMNY . SAMURAI - SJ,JA | Front Drive Shaft | 09283-26016 | 26*38*8 | MUSASHI | Z6111 | '83.7~ |
| Suzuki | JIMNY . SAMURAI - SJ,JA | Rear Wheel | 09283-48007 | 47*62*9 | MUSASHI | Z6108 | '83.7~ |
| Suzuki | JIMNY . SAMURAI - SJ,JA | Transmission Rear | 24780-79001 | 28*38*10/15 | MUSASHI | Z6106 | '83.7~ |
| Suzuki | JIMNY-SAMURAI--JB31 | Wheel Hub Front | 09283-50002 | 50*68*7/9 | MUSASHI | Z6110 | '93.5~ |
| Suzuki | Swift . CULTUS-AA,AB,AH | Front Wheel (Inner) | 09283-44009 | 44*62*8/14 | MUSASHI | Z6127 | '86.6~'88 |
| Suzuki | Swift . CULTUS-AA,AB,AH | Front Wheel (Inner) | 09283-49002 | 49*62*8/11 | MUSASHI | Z6128 | '88.9~'89.6 |
| Suzuki | Swift . CULTUS-AA,AB,AH | Front Wheel (Outer) | 09283-53001 | 53*68.2*7 | MUSASHI | Z6121 | '86.6~'89.6 |
| Suzuki | Swift . CULTUS-AA,AB,AH | Front Wheel (Outer) | 09283-53001 | 53*68.2*7 | MUSASHI | Z6121 | '86.6~'89.6 |

| CAR | MODEL | APPLICATION | OEM NO. | SIZE | DATA acc. | CODE | YEARS |
|--------|--|-----------------------------|--------------------|------------------|-----------|--------|---------------|
| Suzuki | Swift . CULTUS-AA,AB,AH | Front Wheel (Outer) | 09283-56002 | 56*72.2*8/10 | MUSASHI | | '88.9~ |
| Suzuki | Swift A AA33.43.53.AB33.43.53 | | 24151-73B00/960514 | 20*35*5.5 | PAYEN | NJ 758 | |
| Suzuki | Swift A AA41.AB41 | Front wheel inner | 09283-44006/07/09 | 44*62*8/14 | PAYEN | NJ 854 | |
| Suzuki | Swift G10 3 CYL (OHC) 993 cc | Crank Shaft Rear | 09283-68001/02 | 68*86*8 | PAYEN | NJ 378 | |
| Suzuki | Swift G13B 4 CYL (OHC) 1298 cc | Timing Cover | 96051421 | 32*47*6 | PAYEN | NJ 377 | |
| Suzuki | VITARA JLX . ESCUDO-TA | Crank Shaft Rear | 09283-68001 | 68*86*8 | MUSASHI | Z6126 | '88.5~ |
| Suzuki | | Power Steering | | 18*32.69*3.4/8.7 | | | |
| Suzuki | | | 09282-10001 | 10*17*5 | | | |
| Suzuki | | | 09283-26010 | 26*38*7 | | | |
| Suzuki | | | 09283-26007 | 26*52*7/8 | | | |
| Suzuki | | | 09283-32009 | 32*52*10 | PAYEN | NJ760 | |
| Suzuki | | | 09283-35020 | 35*52*10 | PAYEN | NK074 | |
| Suzuki | | | 27611-82300 | 35*55*8 | PAYEN | NJ092 | |
| Suzuki | | | 29972-80050 | 38*50*8 | PAYEN | NK043 | |
| Suzuki | | | 96053884 | 38*55*8.5 | PAYEN | NJ891 | |
| Suzuki | | | 22881-82300 | 38*55*8.5 | PAYEN | NJ891 | |
| Suzuki | | | 29971-80050 | 38*60*8/14.5 | PAYEN | NJ856 | |
| Suzuki | | | 29971-80051 | 38*60*8/14.5 | PAYEN | NJ856 | |
| Suzuki | | | 09283-40013 | 40*72*10/17.5 | PAYEN | NJ961 | |
| Suzuki | | | 96057743 | 54*69*7.5/9.5 | PAYEN | NJ992 | |
| Suzuki | | | 09283-54001 | 54*69*7.5/9.5 | PAYEN | NJ992 | |
| SUZUKI | CP21S | Transmission | 96051419 | 20*35*5.5 | PAYEN | NJ758 | 3/90-on |
| SUZUKI | DT175 | Front folk | 137-23145-01 | 30*40.5*10.5 | | | |
| SUZUKI | G13B 4 cyl (dohc) 1298 cc | Cam Shaft | 96051420 | 32*47*8 | PAYEN | NJ336 | 85-on |
| SUZUKI | G13B 4 cyl (dohc) 1298 cc | Cam Shaft | 09283-32025 | 32*47*8 | PAYEN | NJ336 | 85-on |
| SUZUKI | G13B 4 cyl (dohc) 1298 cc | Crank Shaft Rear | 96051424 | 68*86*8 | PAYEN | NJ378 | 85-on |
| SUZUKI | G13B 4 cyl (ohc) 1298 cc | Crank Shaft Rear | 96065634 | 68*86*8 | PAYEN | NJ378 | 89-on |
| SUZUKI | SS30V | Differential | 09283-35013 | 35*72*7.5/9.5 | PAYEN | NJ851 | 5/79-82 |
| SUZUKI | SS30V | Differential | 09283-35022 | 35*72*7.5/9.5 | PAYEN | NJ851 | 5/79-82 |
| SUZUKI | SS30V | Differential | 09283-35031 | 35*72*7.5/9.5 | PAYEN | NJ851 | 5/79-82 |
| SUZUKI | | | 09283-25037 | 25*44*7 | | | |
| Suzuki | AB51 | Front Wheel | 96055290 | 53*68.2*7 | PAYEN | NJ912 | 8/84-86 |
| Suzuki | Legacy | Engine Oil Pump | | 33*49*8 | MUSASHI | S4888 | '89.2~ |
| Suzuki | ALCYONE.Subaru XT-AX,CX | Engine Oil Pump | | 33*49*8 | MUSASHI | S4888 | '91.9~ |
| Suzuki | ESCUDO.VITARA JLX-TA,TD | Differential Pinion (Front) | 09283-40022 | 40*72*11/18 | MUSASHI | Z6145 | '88.5~ |
| Suzuki | ALTO-CL21V,CM21V,CN21S,CP21S | Wheel Hub Front | | 44*62*8/14 | MUSASHI | Z6120 | '91.9~'94 |
| SUZUKI | CULTUS.Swift-AA,AB,AF,AH,AJ,G A,GB,GC,GD | Wheel Hub Front Inner | 09283-49002 | 49*62*8/11 | MUSASHI | Z6128 | '89.11~'95.1 |
| NISSAN | B12 GEAR FORK | | | 18*32/38*13.5 | | | |
| NISSAN | BLUEBIRD DATSUNTruck,CEDRIC GRORIA,Sunny | Crank Shaft | 12279-21010 | 80*100*13 | MUSASHI | | |
| NISSAN | Cedric Groria | Crank Shaft Front | 13042-76200 | 58*80/88*12 | MUSASHI | | |
| NISSAN | Cedric Groria | Timing Cover | 13042-A3501 | 48*70*9 | MUSASHI | | |
| NISSAN | Junior | Transmission | 32113-86400 | 28*40*8 | MUSASHI | | |
| NISSAN | Junior H-20 | Crank Shaft Front | 13510-78200 | 45*68*12 | MUSASHI | N2032 | '70.1 ~ '71.3 |
| NISSAN | K10 MA10T | Differential Output | 38342-M8001 | 40*56*8 | PAYEN | NJ637 | 2/85-on |
| NISSAN | Laurel,SkylineSkyline,CARAVAN HOMOY | Timing Cover | 13042-A3500 | 48*70*9 | MUSASHI | | |

| CAR | MODEL | APPLICATION | OEM NO. | SIZE | DATA acc. | CODE | YEARS |
|---------------|--|---|-------------|---------------------|-----------|--------|---------------|
| NISSAN | Skyline | Drive Pinion | 38189-02700 | 35*64*13 | MUSASHI | | |
| NISSAN | Stanza | Steering Worm | 49029-W0501 | 17.5*32*7 | MUSASHI | | |
| NISSAN | UD | Diff Drive Pinion | 38189-90005 | 70*115*15 | MUSASHI | | |
| NISSAN | UD | Rear Wheer Outer | 38212-90003 | 60*72*7.5 | MUSASHI | | |
| NISSAN | Vanette (Cherry Sunny DATSUN) | Steering Sector | 48437-H1002 | 25*38*7 | MUSASHI | | |
| NISSAN | Violet AUSTAR | Crank Shaft | 12279-21020 | 80*100*13 | MUSASHI | | |
| NISSAN | | RE8 Crank Shaft Rear | | 138*155*11 | | | |
| NISSAN | | | | 18*32*10/15 | | | |
| NISSAN | BLUEBIRD U12 U12...2WD(SR180) | | 38342-21X00 | 40*56*8*13.5 | PAYEN | NJ 190 | |
| NISSAN | Pulsar-N15...GA15DE,GA16DE,CD20 | Transmission & Differential Mission Case | | 40*56*8/13.5 | MUSASHI | N2283 | '95.1~ |
| NISSAN | Sunny(FWD)-B12...RL4F03A | Transmission & Differential Converter Housing | | 40*56*8/13.5 | MUSASHI | N2283 | '89.5~'90 |
| NISSAN | Sunny(FWD)-B14...GA13DE,GA15DE,GA16DE.CD20 | Transmission & Differential Mission Case | | 40*56*8/13.5 | MUSASHI | N2283 | '94.1~ |
| NISSAN | ED33 4 cyl Diesel 3298 cc | Timing Cover | 12278-T9000 | 62*85*12.5 | PAYEN | NJ 371 | 11/81-11/86 |
| NISSAN DATSON | BLUE BIRD (F.W.D.) | Differential Mission Case Side | 38342-D2100 | 40*56/65*20 | MUSASHI | N2244 | |
| NISSAN DATSUN | Atlas.CABSTAR (2t~3t)-H40 | Crank Shaft Rear | 12279-T7201 | 80*100*10 | MUSASHI | N2208 | '81.12~'86.11 |
| NISSAN DATSUN | Atlas.CABSTAR (2t~3t)-H40 | Crank Shaft Rear | 12279-T7200 | 80*100*10 | MUSASHI | N2208 | '81.12~'86.11 |
| NISSAN DATSUN | Atlas.CABSTAR (2t~3t)-H40 | Crank Shaft Rear | 12279-V1700 | 80*100*10 | MUSASHI | N2208 | '81.12~'86.11 |
| NISSAN DATSUN | Atlas.CABSTAR (2t~3t)-H40 | Rear Wheel Outer | 43252-T9300 | 40*49*10.3 | MUSASHI | N2193 | '81.12~'89.5 |
| NISSAN DATSUN | Atlas.CABSTAR (2t~3t)-H40 | Transmission Front | 32113-66401 | 28*40*8 | MUSASHI | N2000 | '81.12~'86.11 |
| NISSAN DATSUN | Atlas.CABSTAR(1t~1.5t)-F22 | Drive Pinion | 38189-C7000 | 42*76*12/21 | MUSASHI | N2007 | '82.2~'86.11 |
| NISSAN DATSUN | Atlas.CABSTAR(1t~1.5t)-F22 | Front Wheel | 40232-69500 | 54*65*13 | MUSASHI | N2101 | '82.2~'88.10 |
| NISSAN DATSUN | Atlas.CABSTAR(1t~1.5t)-F22 | Rear Wheel Outer | 43232-65000 | 50*67*11 | MUSASHI | N2119 | '82.2~'85.8 |
| NISSAN DATSUN | Atlas.CABSTAR(1t~1.5t)-F22 | Rear Wheel Outer | 43232-21T00 | 68*82*7 | MUSASHI | N2008 | '82.2~ |
| NISSAN DATSUN | Atlas.CABSTAR(1t~1.5t)-F22 | Rear Wheel Outer | 09061-0001P | 68*82*7 | MUSASHI | N2008 | '82.2~'88.12 |
| NISSAN DATSUN | Atlas.CABSTAR(1t~1.5t)-F22 | Transmission Front | 32113-36401 | 28*40*8 | MUSASHI | N2000 | '82.2~ |
| NISSAN DATSUN | Atlas.CABSTAR(1t~1.5t)-F22 | Transmission Rear | 32136-01J00 | 44*62*10 | MUSASHI | | '88.10 |
| NISSAN DATSUN | Atlas.CABSTAR(2t~3t)-H40,H41 | Wheel Hub Front | 40227-0T000 | 77.5*91/96*6.2/10.9 | MUSASHI | N2276 | '91.10~ |
| NISSAN DATSUN | AVENIR-W10...GA16DS | Engine Crank Shaft Front | 13510-V7200 | 40*52*7 | MUSASHI | N2266 | '85.8~'89.5~ |
| NISSAN DATSUN | BLUE BIRD(F.W.D.)- | Differential Mission Case Side | 38342-31X00 | 40*56*8/13.5 | MUSASHI | | '89.10~ |
| NISSAN DATSUN | BLUE BIRD(F.W.D.)- | Rear Shaft | 43252-03E00 | 43*54*6 | MUSASHI | N2215 | '83.10~'89.10 |
| NISSAN DATSUN | BLUE BIRD(FWD) | Transmission & Differential Converter Housing | | 33*56*8/13 | MUSASHI | N2284 | '89.10~'91.9 |

| CAR | MODEL | APPLICATION | OEM NO. | SIZE | DATA acc. | CODE | YEARS |
|---------------|--------------------------------------|--|-------------|----------------|-----------|-------|--------------|
| NISSAN DATSUN | BLUE BIRD(FWD) | Transmission & Differential Mission Case | 38342-M8001 | 40*56*8 | MUSASHI | N2195 | '83.10~'91 |
| NISSAN DATSUN | BLUE BIRD.180B,200B (R.W.D.)-810,910 | Crank Shaft Front | 13510-D0100 | 33*47*8 | MUSASHI | N2210 | '82.10~'83 |
| NISSAN DATSUN | BLUE BIRD.180B,200B (R.W.D.)-810,910 | Crank Shaft Rear | 12279-R4600 | 80*100*13 | MUSASHI | N2159 | '76.7~'83 |
| NISSAN DATSUN | BLUE BIRD.180B,200B (R.W.D.)-810,910 | Crank Shaft Rear | 12279-R4611 | 80*100*13 | MUSASHI | N2159 | '76.7~'83 |
| NISSAN DATSUN | BLUE BIRD.180B,200B (R.W.D.)-810,910 | Steering Sector | 48137-36700 | 26*40*7 | MUSASHI | N2140 | '77.8~'81 |
| NISSAN DATSUN | BLUEBIRD DATSUNTruck | Crank Shaft Front | 13042-A8600 | 48*70*9 | MUSASHI | N2022 | '77.8~'85 |
| NISSAN DATSUN | BLUEBIRD DATSUNTruck | Rear Shaft | 43232-H1000 | 41*56*7 | MUSASHI | | |
| NISSAN DATSUN | Caball-Clipper-C240,C340 | Crank Shaft Front | 13510-E0700 | 45*68*12 | MUSASHI | N2030 | '73~'83.7 |
| NISSAN DATSUN | Caball-Clipper-C240,C340 | Drive Pinion | 38189-31300 | 42*72.5*12 | MUSASHI | N2060 | '73~'83.7 |
| NISSAN DATSUN | Caball-Clipper-C240,C340 | Rear Wheel Inner | 43213-76000 | 78*95*8 | MUSASHI | N2116 | '73~'83.7 |
| NISSAN DATSUN | Caball-Clipper-C240,C340 | Steering Sector | 48404-82100 | 35*48*8 | MUSASHI | N2135 | '80.6~ |
| NISSAN DATSUN | Cabstar Homer | Rear Shaft | 43252-10300 | 38*62*11 | MUSASHI | | |
| NISSAN DATSUN | Cabstar-Homer-F20 | Crank Shaft Front | 13042-B3000 | 39.7*62*11 | MUSASHI | N2023 | '76.1~'81.12 |
| NISSAN DATSUN | Cabstar-Homer-F20 | Crank Shaft Front | 13043-T8200 | 58*80*12 | MUSASHI | N2028 | '76.1~'81.12 |
| NISSAN DATSUN | Cabstar-Homer-F20 | Crank Shaft Front | 13043-T7200 | 58*80*12 | MUSASHI | N2028 | '76.1~'81.12 |
| NISSAN DATSUN | Cabstar-Homer-F20 | Drive Pinion | 09062-0020P | 42*76*12/21 | MUSASHI | N2007 | '76.1~'81.12 |
| NISSAN DATSUN | Cabstar-Homer-F20 | Steering Sector | 48040-84500 | 32*43*7 | MUSASHI | | '76.1~'81.12 |
| NISSAN DATSUN | Caravan Homy Urvan | Engine Crank Shaft Front | | 39.7*62*11 | MUSASHI | N2023 | '75.11~'82 |
| NISSAN DATSUN | Caravan Homy Urvan | Steering Worm | | 36*50*7 | MUSASHI | N2336 | '86.9~'88 |
| NISSAN DATSUN | Caravan Homy Urvan-E20,E23,E24 | Crank Shaft Front | 13510-05E00 | 46*58*8 | MUSASHI | | '86.9~ |
| NISSAN DATSUN | Caravan Homy Urvan-E20,E23,E24 | Final Drive Pinion (Rear) | 38189-N3100 | 40*75/81*14/21 | MUSASHI | N2296 | '91.7~ |
| NISSAN DATSUN | Caravan Homy Urvan-E20,E23,E24 | Front Wheel | 26134-6401P | 57*73*7 | MUSASHI | N2034 | '75.11~'78.3 |
| NISSAN DATSUN | Caravan Homy Urvan-E20,E23,E24 | Rear Wheel Outer | 43232-B5000 | 50*67*11 | MUSASHI | N2119 | '75.11~'86.8 |
| NISSAN DATSUN | Caravan Homy Urvan-E20,E23,E24 | Rear Wheel Outer | 43232-01G10 | 50*70*12/17 | MUSASHI | N2223 | '86.9~ |
| NISSAN DATSUN | CAVAII Clipper | Diff Drive Pinion | 38189-12000 | 40*62*11 | MUSASHI | | |
| NISSAN DATSUN | CAVAII Clipper | Front Wheel | 40227-30100 | 60*82*7 | MUSASHI | | |
| NISSAN DATSUN | CD17 4 cyl Diesel 1681 cc | Cam Shaft (Rear) | 13042-16A10 | 36*50*8 | PAYEN | NJ283 | '82.10~ |
| NISSAN DATSUN | Cedric Goria | Diff Drive Pinion | 38189-61000 | 45*75*12 | MUSASHI | | |

| CAR | MODEL | APPLICATION | OEM NO. | SIZE | DATA acc. | CODE | YEARS |
|------------------|-----------------------------------|-------------------------|-------------|---------------|-----------|-------|--------------|
| NISSAN DATSUN | Cedric Gromia | Diff Drive Pinion | 38189-61001 | 45*75*12 | MUSASHI | | |
| NISSAN DATSUN | Cedric Gromia | Front Wheel | 40232-89500 | 54*65*13 | MUSASHI | | |
| NISSAN DATSUN | Cedric Gromia | Steering Sector | 48137-26760 | 25*40*7 | MUSASHI | | |
| NISSAN DATSUN | Cedric.240C,260C,280C-430,Y30,Y31 | Cam Shaft | 13042-16405 | 34*48*8 | MUSASHI | N2212 | '83.6~'87.6 |
| NISSAN DATSUN | Cedric.240C,260C,280C-430,Y30,Y31 | Crank Shaft Front | 13043-76200 | 58*80*12 | MUSASHI | N2028 | '79.6~'83.5 |
| NISSAN DATSUN | Cedric.240C,260C,280C-430,Y30,Y31 | Front Wheel | 40232-B9500 | 54*65*13 | MUSASHI | N2101 | '79.6~'87.5 |
| NISSAN DATSUN | Cefiro-A31 | Crank Shaft Front | 13510-19V00 | 40*52*7 | MUSASHI | N2266 | '85.8~'89.5~ |
| NISSAN DATSUN | Cefiro-A31 | Crank Shaft Rear | 12279-01M00 | 80*100*10 | MUSASHI | N2187 | '81.8~'89.5 |
| NISSAN DATSUN | Cherry-F10 | Differential | 38342-M3000 | 36*55*11/16 | MUSASHI | N2086 | '74.9~'78.4 |
| NISSAN DATSUN | Cherry-F10 | Rear Shaft | 43252-M0200 | 39*51*7.5 | MUSASHI | N2126 | '74.9~'78.4 |
| NISSAN DATSUN | Civilian-W40 | Crank Shaft Front | 12278-T9000 | 62*85*12.5 | MUSASHI | N2272 | '82.8~'88.5 |
| NISSAN DATSUN | Civilian-W40 | Crank Shaft Rear | 12278-T9001 | 105*135*12.5 | MUSASHI | N2273 | '82.8~ |
| NISSAN DATSUN | Civilian-W40 | Crank Shaft Rear | 12279-01T00 | 105*135*12.5 | MUSASHI | N2273 | '82.8~ |
| NISSAN DATSUN | Civilian-W40 | Crank Shaft Rear | 12279-43G00 | 86*100*10 | MUSASHI | N2256 | '88.5~ |
| NISSAN DATSUN | Civilian-W40 | Drive Pinion | 38189-J2000 | 42*72.5*12 | MUSASHI | N2060 | '82.8~ |
| NISSAN DATSUN | Civilian-W40 | Drive Pinion | 38189-61500 | 56*72*9 | MUSASHI | N2070 | '84.5~ |
| NISSAN DATSUN | Civilian-W40 | Front Wheel | 40227-J5110 | 60*82*7 | MUSASHI | N2154 | '82.8~ |
| NISSAN DATSUN | Civilian-W40 | Rear Wheel Inner | 43252-82100 | 80*105*13 | MUSASHI | N2128 | '82.8~'88.5 |
| NISSAN DATSUN | Civilian-W40 | Steering Worm | 48029-04100 | 17*31*7 | MUSASHI | N2132 | '77.8~'81 |
| NISSAN DATSUN | Civilian-W40 | Transmission Front | 32219-Z5004 | 32*45*8 | MUSASHI | N2053 | '84.6~ |
| NISSAN DATSUN | Civilian-W40 | Transmission Front | 32219-Z5000 | 32*45*8 | MUSASHI | N2053 | '84.6~ |
| NISSAN DATSUN | Civilian-W40 | Transmission Rear | 32136-J2000 | 40*62*11 | MUSASHI | N2003 | '82.8~ |
| NISSAN DATSUN | Civilian-W40 | Transmission Rear | 32136-J6500 | 40*62*11 | MUSASHI | N2003 | '82.8~ |
| NISSAN DATSUN | Civilian-W40 | Transmission Rear | 32136-Z5000 | 58*75*9 | MUSASHI | N2043 | '84.6~'88.5 |
| NISSAN DATSUN | Civilian-W40 | Transmission Rear | 32136-Z5002 | 58*75*9 | MUSASHI | N2043 | '84.6~'88.5 |
| NISSAN DATSUN | DATSUN Truck | Steering Sector | 49321-Y0100 | 28*40*8 | MUSASHI | N2173 | '79.6~'83.5 |
| NISSAN DATSUN | DATSUN Truck | Steering Sector Shaft | | 34*44*8 | MUSASHI | | '92.38 |
| NISSAN DATSUN | Datsun Truck-620,720,D21 | Transfer Cover | | 50*72*12 | MUSASHI | N2316 | '92.8~ |
| NISSAN DATSUN | Datsun Truck-Pick up-620,720,D21 | Front Wheel | 40227-73000 | 48*65*10 | MUSASHI | N2097 | '72~'77.8 |
| NISSAN DATSUN | Datsun Truck-Pick up-620,720,D21 | Front Wheel (Dust Seal) | 40227-50W00 | 50*72/83*16.2 | MUSASHI | N2232 | '83.4~'85.7 |

| CAR | MODEL | APPLICATION | OEM NO. | SIZE | DATA acc. | CODE | YEARS |
|------------------|---------------------------------------|-------------------------------------|-------------|---------------|-----------|-------|---------------|
| NISSAN DATSUN | Datsun Truck-Pick up-620,720,D21 | Front Wheel (Dust Seal) | 40227-50W01 | 50*72/83*16.2 | MUSASHI | N2232 | '83.4~'85.7 |
| NISSAN DATSUN | Junior | Front Wheel | 40227-15110 | 60*82*7 | MUSASHI | | |
| NISSAN DATSUN | Junior | Rear Wheel | 43223-30100 | 74*95*7 | MUSASHI | N2034 | |
| NISSAN DATSUN | Junior | Transmission Rear | 32136-12000 | 40*62*11 | MUSASHI | | |
| NISSAN DATSUN | Laurel | Rear Shaft | 43252-18000 | 41*56*7 | MUSASHI | | |
| NISSAN DATSUN | Laurel.180L.200L.24 0L-C31,C32,C33 | Cam Shaft | 13042-D0103 | 34*48*8 | MUSASHI | N2212 | '82.10~'88.12 |
| NISSAN DATSUN | Laurel.180L.200L.24 0L-C31,C32,C33 | Cam Shaft | 13042-16V03 | 40*52*7 | MUSASHI | N2266 | '84.10~ |
| NISSAN DATSUN | Laurel.180L.200L.24 0L-C31,C32,C33 | Drive Pinion | 38189-U3000 | 35*67*12/18 | MUSASHI | N2062 | '80.11~'88.12 |
| NISSAN DATSUN | Laurel.180L.200L.24 0L-C31,C32,C33 | Rear Wheel | 43252-H1010 | 41*56*7 | MUSASHI | N2125 | '80.11~'88.12 |
| NISSAN DATSUN | Leopard | Front Wheel | 40232-H7100 | 46*59.1*12/13 | MUSASHI | | |
| NISSAN DATSUN | Leopard-F30,F31 | Crank Shaft Rear | 12279-18V00 | 84*104*11 | MUSASHI | | '89.2~ |
| NISSAN DATSUN | March-K10 | Crank Shaft Rear | 12279-01B11 | 75*94*10 | MUSASHI | N2263 | '82.10~ |
| NISSAN DATSUN | March-K10 | Crank Shaft Rear | 12279-01B01 | 75*94*10 | MUSASHI | N2263 | '82.10~ |
| NISSAN DATSUN | March-K10 | Crank Shaft Rear | 12279-01B00 | 75*94*10 | MUSASHI | N2263 | '82.10~ |
| NISSAN DATSUN | March-K10 | Differential Oluten Housing Side | 38342-01B00 | 38*58*11/17 | MUSASHI | N2246 | '82.10~ |
| NISSAN DATSUN | March-K10 | Front Wheel (Grease Seal) | 40232-21B00 | 52*68*7.5/12 | MUSASHI | N2260 | '88.8~'89.1 |
| NISSAN DATSUN | March-K10 | Rear Shaft | 43252-01B00 | 38*50.3*10 | MUSASHI | N2204 | '82.10~'89.1 |
| NISSAN DATSUN | March-K10 | Transmission Input Shaft | 32113-01B00 | 20*35*8 | MUSASHI | N2185 | '82.10~ |
| NISSAN DATSUN | March-K10,K11 | Steering Gear | | 16*26*7 | MUSASHI | N2288 | '92.1~ |
| NISSAN DATSUN | Patrol-160,Y16 | Front Wheel Dust Seal | 40227-C6000 | 65*88*11/16.5 | MUSASHI | N2165 | '80.6~'83.4 |
| NISSAN DATSUN | Prairie | Engine Crank Shaft Rear | 12279-42L00 | 80*100*10 | MUSASHI | N2187 | '84.10~'89.12 |
| NISSAN DATSUN | Prairie-M10,M11 | Crank Shaft Front | 13510-01M00 | 36*49*7 | MUSASHI | N2186 | '81.10~'89 |
| NISSAN DATSUN | Prairie-M10,M11 | Front Wheel (Grease Seal) | 40232-M5610 | 52*67*7 | MUSASHI | N2106 | '82.8~'88.8 |
| NISSAN DATSUN | Prairie-M10,M11 | Front Wheel (Grease Seal) | 40232-M5611 | 52*67*7 | MUSASHI | N2106 | '82.8~'88.8 |
| NISSAN DATSUN | President | Diff Drive Pinion | 38183-N3100 | 40*75*12/17.5 | MUSASHI | N2061 | |
| NISSAN DATSUN | Pulsar | Jack Shaft | 13168-01M00 | 32*50*8 | MUSASHI | N2189 | '81.10~'89 |
| NISSAN DATSUN | Pulsar.Langley- N10,N12,N13 | Cam Shaft | 13042-D0100 | 34*48*8 | MUSASHI | N2212 | '82.10~'89.5 |
| NISSAN DATSUN | Pulsar.Langley- N10,N12,N13 | Cam Shaft | 13042-16A05 | 34*48*8 | MUSASHI | N2212 | '82.10~'89.5 |
| NISSAN DATSUN | Pulsar.Langley- N10,N12,N13 | Cam Shaft (Back Side) | 13042-16A10 | 36*50*8 | MUSASHI | | '86.5~ |
| NISSAN DATSUN | Pulsar.Langley- N10,N12,N13 | Crank Shaft Front | 13510-77A05 | 40*52*7 | MUSASHI | N2266 | '87.9~'90.1 |

| CAR | MODEL | APPLICATION | OEM NO. | SIZE | DATA acc. | CODE | YEARS |
|------------------|---|-------------------------------------|-------------|---------------|-----------|-------|---------------|
| NISSAN DATSUN | Pulsar.Langley- N10,N12,N13 | Crank Shaft Front | 13042-42L00 | 40*52*7 | MUSASHI | N2266 | '85.8~'89.5~ |
| NISSAN DATSUN | Pulsar.Langley- N10,N12,N13 | Crank Shaft Rear | 12279-77A10 | 84*104*11 | MUSASHI | N2211 | '81.10~'89 |
| NISSAN DATSUN | Pulsar.Langley- N10,N12,N13 | Crank Shaft Rear | 12279-77A05 | 84*104*11 | MUSASHI | N2211 | '81.10~'89 |
| NISSAN DATSUN | Pulsar.Langley- N10,N12,N13 | Front Wheel (Dust Seal) | 40227-M5605 | 52*68*13 | MUSASHI | N2091 | '78.5~'86 |
| NISSAN DATSUN | Pulsar.Langley- N10,N12,N13 | Front Wheel (Dust Seal) | 40227-M5601 | 52*68*13 | MUSASHI | N2091 | '78.5~'86 |
| NISSAN DATSUN | Pulsar.Langley- N10,N12,N13 | Front Wheel (Grease Seal) | 40232-M5661 | 52*67*7 | MUSASHI | N2106 | '78.5~'86 |
| NISSAN DATSUN | Pulsar.Langley- N10,N12,N13 | Front Wheel (Grease Seal) | 40232-M5600 | 52*67*7 | MUSASHI | N2106 | '78.5~'86 |
| NISSAN DATSUN | Pulsar.Langley- N10,N12,N13 | Jack Shaft | 13166-01M00 | 32*50*8 | MUSASHI | N2189 | '81.3~ |
| NISSAN DATSUN | Pulsar.Langley- N10,N12,N13 | Rear Shaft | 43232-50A00 | 40*52*6/10 | MUSASHI | N2240 | '86.5~ |
| NISSAN DATSUN | Pulsar.Langley- N10,N12,N13 | Rear Shaft | 43232-50A10 | 40*52*6/10 | MUSASHI | N2240 | '86.5~ |
| NISSAN DATSUN | Pulsar.Langley- N10,N12,N13 | Rear Shaft | 43252-M7000 | 43*54*7.5 | MUSASHI | N2152 | '78.5~'86 |
| NISSAN DATSUN | Silvia GASSELE | Rear Shaft | 43252-N1000 | 41*56*7 | MUSASHI | | |
| NISSAN DATSUN | Skyline | Steering Worm | 48125-S5001 | 19*32*8 | MUSASHI | | |
| NISSAN DATSUN | Skyline- C210,R30,R31,R32 | Front Wheel | 40232-33P10 | 56*76*6/12 | MUSASHI | N2274 | '89.5~ |
| NISSAN DATSUN | Stanza.AUSTER(F. W.D)-T11.T12 | Cam Shaft | 13042-16V00 | 40*52*7 | MUSASHI | N2266 | '85.8~'89.5 |
| NISSAN DATSUN | Stanza.AUSTER(F. W.D)-T11.T12 | Cam Shaft | 13042-42100 | 40*52*7 | MUSASHI | N2266 | '85.10~ |
| NISSAN DATSUN | Stanza.AUSTER(F. W.D)-T11.T12 | Differential Clutch Housing Side | 38342-03E01 | 33*59*11/17 | MUSASHI | N2250 | '85.10~ |
| NISSAN DATSUN | Stanza.AUSTER(F. W.D)-T11.T12 | Differential Mission Case Side | 38342-03E00 | 39*59*11/17 | MUSASHI | N2249 | '85.10~ |
| NISSAN DATSUN | Stanza.AUSTER(F. W.D)-T11.T12 | Rear Shaft | 43252-03E01 | 43*54*6 | MUSASHI | N2215 | '85.10~ |
| NISSAN DATSUN | Stanza.AUSTER(F. W.D)-T11.T12 | Rear Shaft | 43252-M7001 | 43*54*7.5 | MUSASHI | N2152 | '81.6~'85 |
| NISSAN DATSUN | Stanza.AUSTER(F. W.D)-T11.T12 | Steering Gear | 48125-01E00 | 17*30*8 | MUSASHI | N2207 | '84.10~'88.12 |
| NISSAN DATSUN | Stanza.AUSTER(F. W.D)-T11.T12 | Transmission Input Shaft | 32113-M8000 | 25*40*8 | MUSASHI | N2178 | '81.6~'85.10 |
| NISSAN DATSUN | Stanza.AUSTER(F. W.D)- T11.T12Stanza.AUS TER(F.W.D)- | Crank Shaft Rear | 12279-D0100 | 84*104*11 | MUSASHI | N2211 | '82.10~ |
| NISSAN DATSUN | Stanza.AUSTER(R. W.D.)-A10.A11 | Crank Shaft Front | 13510-H1000 | 38*55*9 | MUSASHI | N2031 | '77.5~'81 |
| NISSAN DATSUN | Stanza.AUSTER(R. W.D.)-A10.A11 | Crank Shaft Front | 13042-A3510 | 48*70*9 | MUSASHI | N2022 | '77.5~'81 |
| NISSAN DATSUN | Stanza.AUSTER(R. W.D.)-A10.A11 | Crank Shaft Rear | 12279-H2301 | 60*82*12 | MUSASHI | N2160 | '77.5~'81 |
| NISSAN DATSUN | Stanza.AUSTER(R. W.D.)-A10.A11 | Crank Shaft Rear | 12279-H2311 | 60*82*12 | MUSASHI | N2160 | '77.5~'81 |
| NISSAN DATSUN | Stanza.AUSTER(R. W.D.)-A10.A11 | Front Wheel | 38342-M8001 | 42*55*8 | MUSASHI | N2110 | '77.5~'81 |
| NISSAN DATSUN | Stanza.AUSTER(R. W.D.)-A10.A11 | Front Wheel | 40232-N7100 | 46*59.1*12/13 | MUSASHI | N2107 | '77.5~'81 |

| CAR | MODEL | APPLICATION | OEM NO. | SIZE | DATA acc. | CODE | YEARS |
|---------------|-----------------------------------|----------------------------------|-------------|---------------------|-----------|-------|---------------|
| NISSAN DATSUN | Stanza.AUSTER(R.W.D.)-A10.A11 | Rear Shaft | 43252-H0101 | 41*56*7 | MUSASHI | N2125 | '77.5~'81 |
| NISSAN DATSUN | Stanza.AUSTER(R.W.D.)-A10.A11 | Transmission Rear | 32136-H5000 | 30*45/77*45 | MUSASHI | N2042 | '77.5~'81 |
| NISSAN DATSUN | Stanza.AUSTER(R.W.D.)-A10.A11 | Transmission Rear | 32136-H8900 | 30*45/77*45 | MUSASHI | N2042 | '77.5~'81 |
| NISSAN DATSUN | Sunny | Steering Worm | 48029-H5000 | 17*30*7 | PAYEN | NJ621 | |
| NISSAN DATSUN | Sunny(F.W.D.)-B11,VB11,B12,B13 | Front Wheel (Grease Seal) | 40232-50Y00 | 55*68/72.8*8/11.8 | MUSASHI | N2264 | '90.1~ |
| NISSAN DATSUN | Sunny(F.W.D.)-B11,VB11,B12,B13 | Rear Shaft (Inner) | 40232-50Y10 | 55*68/72.8*8/11.8 | MUSASHI | N2264 | '90.1~ |
| NISSAN DATSUN | Sunny(F.W.D.)-B11,VB11,B12,B13 | Rear Shaft (Outer) | 42557-50Y01 | 56*74.2/78*7.5/10.7 | MUSASHI | N2265 | |
| NISSAN DATSUN | Sunny(R.W.D.)-B110,B210,B310,B120 | Front Wheel | 40232-18000 | 38*52*9.5 | MUSASHI | N2109 | '71.10~'73.4 |
| NISSAN DATSUN | Sunny(R.W.D.)-B110,B210,B310,B120 | Front Wheel | 40232-21000 | 42*55*8 | MUSASHI | N2110 | '73.4~'83 |
| NISSAN DATSUN | Sunny(R.W.D.)-B110,B210,B310,B120 | Steering Sector | 48137-H1002 | 25*38*7 | MUSASHI | N2136 | '78.10~'88.8 |
| NISSAN DATSUN | Sunny(R.W.D.)-B110,B210,B310,B120 | Steering Worm | 48029-H5000 | 17*30*7 | MUSASHI | N2133 | '71.10~'83 |
| NISSAN DATSUN | Sunny(R.W.D.)-B110,B210,B310,B120 | Transmission Front | 32113-13200 | 24*40*8 | MUSASHI | N2036 | '71.10~'83 |
| NISSAN DATSUN | Sunny(R.W.D.)-B110,B210,B310,B120 | Transmission Rear | 32136-H6900 | 30*45/77*45 | MUSASHI | N2042 | '77.10~'83 |
| NISSAN DATSUN | Sunny(R.W.D.)-B110,B210,B310,B120 | Transmission Rear | 32136-E0100 | 35*50*11 | MUSASHI | N2045 | '71.10~'77.10 |
| NISSAN DATSUN | Vanette (Cherry Sunny DATSUN) | Steering Sector | 12279-H2300 | 60*82*12 | MUSASHI | | |
| NISSAN DATSUN | Vanette (Cherry Sunny DATSUN) | Transmission Rear | 32135-H5000 | 30*45/77*45 | MUSASHI | | |
| NISSAN DATSUN | Vanette-C120,C22 | Rear Shaft Outer | 43252-G3200 | 25*35*7 | MUSASHI | N2190 | '82.10~'88.10 |
| NISSAN DATSUN | | Crank Shaft Front | 13510-16A00 | 33*47*8 | MUSASHI | N2210 | '81.10~ |
| NISSAN DATSUN | | Crank Shaft Front | 13510-77A10 | 40*52*7 | MUSASHI | N2266 | '87.9~'90.1 |
| NISSAN DATSUN | | Crank Shaft Rear | 12279-18010 | 60*82*12 | MUSASHI | N2017 | '78.10~'85.9 |
| NISSAN DATSUN | | Crank Shaft Rear | 12279-H1000 | 60*82*12 | MUSASHI | N2017 | '78.10~'85.9 |
| NISSAN DATSUN | | Crank Shaft Rear | 12279-85G00 | 80*100*10 | MUSASHI | | '89.9~ |
| NISSAN DATSUN | | Crank Shaft Rear | 12279-T7203 | 80*100*10 | MUSASHI | N2208 | '82.1~'87.8 |
| NISSAN DATSUN | | Crank Shaft Rear | 12279-T7202 | 80*100*10 | MUSASHI | N2208 | '82.1~'87.8 |
| NISSAN DATSUN | | Crank Shaft Rear | 12279-R4601 | 80*100*13 | MUSASHI | N2159 | '77.8~'85 |
| NISSAN DATSUN | | Crank Shaft Rear | 12279-16V00 | 84*104*11 | MUSASHI | | '89.3~'89.7 |
| NISSAN DATSUN | | Differential Clutch Housing Side | 38342-31X01 | 33*56*8/13 | MUSASHI | | '90.1~ |

| CAR | MODEL | APPLICATION | OEM NO. | SIZE | DATA acc. | CODE | YEARS |
|------------------|-------------------------------|--|--------------|-----------------|-----------|-------|--------------|
| NISSAN DATSUN | | Steering Sector | 48137-G4000 | 28.6*40*8 | MUSASHI | | '85.9 |
| NISSAN DATSUN | | Steering Worm | 48125-85001 | 19*32*8 | MUSASHI | N2176 | '77.8~'81 |
| NISSAN DATSUN | ALL | Differential Dinion | 38189-A6100 | 35*64*13 | PAYEN | NJ038 | 10/75-2/79 |
| NISSAN DATSUN | ALL | Rear Wheel | 43232-P4500 | 35*55*11 | PAYEN | NJ274 | 6/83-12/87 |
| NISSAN DATSUN | ALL | Rear Wheel | 43252-H1010 | 41*56*7 | PAYEN | NJ036 | 3/79-7/83 |
| NISSAN DATSUN | ED33T 4 cyl Diesel 3298 cc | Crank Shaft Rear | 12278-01T00 | 105*135*12.5 | PAYEN | NJ372 | 6/84-5/88 |
| DS | BLUE BIRD(F.W.D.)- | Differential Mission Case Side | 38342-31X00 | 40*56*8*13.5 | MUSASHI | | '89.10~ |
| DS | BLUE BIRD(FWD) | Transmission & Differential Mission Case | | 40*56*8*13.5 | MUSASHI | N2283 | '89.10~'91.9 |
| DS | U12 2WD(SR18DI) | Differential transmission side | 383432-31X00 | 40*56*8/13.5 | PAYEN | NJ190 | 10/89-on |
| NISSAN DIESEL.UD | Caball-Clipper-C240,C340 | Crank Shaft Front | 12278-90016 | 62*85/93*13 | MUSASHI | N2168 | '74~'83 |
| NISSAN DIESEL.UD | Condor Truck 3.5t~7t- | Drive Pinion | 38189-90016 | 80*135*12/26 | MUSASHI | N2161 | '85.7~ |
| NISSAN DIESEL.UD | Condor Truck 3.5t~7t- | Front Wheel | 40227-Z5000 | 100*114*12 | MUSASHI | N2092 | '74.9~'85.5 |
| NISSAN DIESEL.UD | Condor Truck 3.5t~7t- | Front Wheel | 40232-C0400 | 85*111*10 | MUSASHI | N2102 | '79.6~'80 |
| NISSAN DIESEL.UD | Condor Truck 3.5t~7t- | Rear Wheel Inner | 43090-Z5001 | 127*146*10 | MUSASHI | N2180 | '83.5~'85.5 |
| NISSAN DIESEL.UD | Condor Truck 3.5t~7t- | Rear Wheel Inner | 43090-Z5000 | 130*150*10 | MUSASHI | N2113 | '74.9~'83 |
| NISSAN DIESEL.UD | Condor Truck 3.5t~7t- | Rear Wheel Inner | 43090-90060 | 154*175*13 | MUSASHI | N2221 | '85.7~ |
| NISSAN DIESEL.UD | Condor Truck 3.5t~7t- | Rear Wheel Outer | 38212-Z5000 | 47*56*7 | MUSASHI | N2074 | '74.9~'83.5 |
| NISSAN DIESEL.UD | Condor Truck 3.5t~7t- | Transmission Front | 32219-Z5003 | 32*45*8 | MUSASHI | N2053 | '74.9~'85.5 |
| NISSAN DIESEL.UD | Condor Truck 3.5t~7t- | Transmission Rear | 32136-Z5003 | 65*78*9 | MUSASHI | | '84.11~'85.5 |
| NISSAN DIESEL.UD | Condor Truck 3.5t~7t- | Transmission Rear | 32136-90062 | 70*88*12 | MUSASHI | N2051 | '85.7~ |
| NISSAN DIESEL.UD | Nissan UD Truck 6t~8t-CK,TK | Drive Pinion | 38189-50000 | 64*85*12 | MUSASHI | N2068 | '70~'79 |
| NISSAN DIESEL.UD | Nissan UD Truck 6t~8t-CK,TK | Rear Wheel Inner | 43090-90014 | 154*175*13 | MUSASHI | N2221 | '85.5~'90 |
| NISSAN DIESEL.UD | Nissan UD Truck 6t~8t-CK,TK | Rear Wheel Inner | 43090-58000 | 95*135*13 | MUSASHI | N2205 | '70~'79 |
| NISSAN DIESEL.UD | Nissan UD Truck 6t~8t-CK,TK | Rear Wheel Outer | 38212-90006 | 60*72*7.5 | MUSASHI | N2080 | '70~'90 |
| NISSAN DIESEL.UD | Nissan UD Truck 6t~8t-CK,TK | Transmission Rear | 32136-C0400 | 55*70*9 | MUSASHI | N2182 | '70~'79 |
| NISSAN DIESEL.UD | Nissan UD Truck 6t~8t-CK,TK | Transmission Rear | 32136-90002 | 70*88*12 | MUSASHI | N2051 | '79.10~'90 |
| NISSAN DIESEL.UD | Nissan UD Truck 6t~8t-CK,TK | Transmission Rear | 32136-90102 | 70*88*12 | MUSASHI | N2052 | '70~'79 |
| NISSAN DIESEL.UD | Nissan UD Truck 6t~8t-CK,TK | Transmission Rear | 32136-90007 | 70*88*12 | MUSASHI | N2052 | '70~'79 |
| NISSAN DIESEL.UD | Nissan UD Truck(10t~12t)-CW | Drive Pinion (Front) | 38189-90008 | 105*135*14 | MUSASHI | N2073 | '72~'77 |
| NISSAN DIESEL.UD | Nissan UD Truck(10t~12t)-CW | Drive Pinion (Front) | 38189-90101 | 105*135*14/20.5 | MUSASHI | | '77~'90 |

| CAR | MODEL | APPLICATION | OEM NO. | SIZE | DATA acc. | CODE | YEARS |
|------------------|---|--|-------------------|---------------------|-----------|--------|--------------|
| NISSAN DIESEL.UD | Nissan UD Truck(10t~12t)-CW | Drive Pinion (Rear) | 38189-90007 | 85*125*14 | MUSASHI | N2072 | '72~'77 |
| NISSAN DIESEL.UD | Nissan UD Truck(10t~12t)-CW | Transmission Front | 32219-90004 | 42*55*9 | MUSASHI | N2174 | '72~'76.2 |
| NISSAN DIESEL.UD | UD | Drive Pinion | 38189-90002 | 70*115*15 | MUSASHI | N2071 | '76.3~'80.1 |
| NISSAN DIESEL.UD | | Crank Shaft Front | 12276-Z5501 | 58*82*10 | MUSASHI | | '84.11~ |
| NISSAN DIESEL.UD | | Crank Shaft Front | 12278-Z5500 | 60*82*12 | MUSASHI | | '83.5~'85 |
| NISSAN DIESEL.UD | | Crank Shaft Front | 12278-97000 | 70*88*8 | MUSASHI | | '86~'83 |
| NISSAN DIESEL.UD | | Crank Shaft Rear | 12279-95000 | 120*140/146*13 | MUSASHI | N2170 | '70~'79 |
| NISSAN DIESEL.UD | | Crank Shaft Rear | 12260-97002 | 132*150/156*14 | MUSASHI | | '84~'85 |
| NISSAN DIESEL.UD | | Crank Shaft Rear | 12279-97003 | 133*157*14 | MUSASHI | | '85~ |
| NISSAN DIESEL.UD | | Drive Pinion | 38189-90009 | 65*95*14 | MUSASHI | N2206 | '76.3~'80.1 |
| NISSAN UD | Silvia S10 ALL | Transmission | 32113-14601/20100 | 33*50*7 | PAYEN | NJ 079 | |
| KUBOTA | SR75 | | 09503-06210 | 30*62*10 | | | |
| NISSAN UD | DATSUN MARCH K11◆CG10DE | Mission & Differential (MTM) INPUT SHAFT | 32113-01B00 | 20*35*8 | MUSASHI | N2185 | 92.1~97.5 |
| NISSAN DIESEL | UD CZ TRUCK (ALL WHEEL DRIVE) CZ520 | Wheel Hub REAR INNER (F&R) | 43090-00Z00 | 154*175/180*13/15.5 | MUSASHI | N2259 | 89.10~95. |
| NISSAN DIESEL | UD CF TRUCK (4WD) CF52,53,55,520◆L | Differential PINION | 38189-90018 | 80*135/146*15/26 | MUSASHI | | 95.2~01. |
| NISSAN DIESEL | UD CV TRUCK (2-2XD) CV40 | Differential CENTER | 38189-90002 | 70*115*15 | MUSASHI | N2071 | 72.~76. |
| NISSAN UD | A12 4 cyl (ohv) 1171 cc | Crank Shaft Rear | 12279-H1000 | 60*82*12 | PAYEN | NJ021 | 71-78 |
| NISSAN UD | A12 4 cyl (ohv) 1171 cc | Timing Cover | 13510-18000 | 38*55*9 | PAYEN | NJ022 | 71-78 |
| NISSAN UD | A14 4 cyl (ohv) 1397 cc | Timing Cover | 13510-H1010 | 38*55*9 | PAYEN | NJ022 | 76- on |
| NISSAN UD | Atlas-CABSTAR(1t~1.5t)-F22,F23...TD27(4W | Transmission Rear Extension | | 44*62*10 | MUSASHI | ※ | '88.10~ |
| NISSAN UD | Atlas-CABSTAR(2t~3t)-H40...Double Tire | Wheel Hub Rear Inner | | 80*105*13 | MUSASHI | N2128 | '81.12~'91 |
| NISSAN UD | Atlas-CABSTAR(2t~3t)-H40...ED33,ED35,F D33#,FD35# | Engine Crank Shaft Front | | 62*85*12.5 | MUSASHI | N2272 | '81.12~'91 |
| NISSAN UD | Atlas-CABSTAR(2t~3t)-H40...Except FD35# | Transmission Rear Extension | | 40*62*11 | MUSASHI | N2003 | '86.11~'91 |
| NISSAN UD | Atlas-CABSTAR(2t~3t)-H40...SB.KP.(ED33 +ED35) | Wheel Hub Rear Outer | | 40*49*10.3 | MUSASHI | N2193 | '86.11~'89.5 |
| NISSAN UD | Atlas-CABSTAR(2t~3t)-H41...ED35 | Engine Crank Shaft Front | | 105*135*12.5 | MUSASHI | N2273 | '91.10~ |
| NISSAN UD | BLUE BIRD(FWD)-U11,U12...LD20 | Engine Crank Shaft Front | | 46*58*8 | MUSASHI | N2311 | '83.10~'89 |

| CAR | MODEL | APPLICATION | OEM NO. | SIZE | DATA acc. | CODE | YEARS |
|-----------|--------------------------------------|--|-------------------|---------------|-----------|--------|--------------|
| NISSAN UD | BLUE BIRD(FWD)-U11...Van | Wheel Hub Rear | | 43*54*7.5 | MUSASHI | N2152 | '83.10~'85.8 |
| NISSAN | BLUEBIRD 810 ALL | Steering Worm | 48029-04100 | 18*31*7 | PAYEN | NJ 641 | |
| NISSAN UD | BLUEBIRD 910 910...Z18P.DL20.F4 | Steering Sector | 48137-26760/36700 | 25*40*7 | PAYEN | NJ 119 | |
| NISSAN | BLUEBIRD U11 ALL | Front wheel outer | 40232-01E01 | 56*72*6.5/11 | PAYEN | NJ 694 | |
| NISSAN UD | BLUEBIRD U12 U12...2WD(SR180) | Differential | 38342-21X00 | 40*56*8/13.5 | PAYEN | NJ 190 | |
| NISSAN UD | BLUEBIRD U12 U12...CA18D.LD20 | | 38342-03E00 | 39*59*11/17 | PAYEN | NJ 213 | |
| NISSAN | Bus RA RA50.51.60 | Rear wheel inner | 43090-90000 | 124*170*14.5 | PAYEN | NJ 388 | |
| NISSAN | Bus RM | Front wheel | 40227-Z5000 | 100*114*12 | PAYEN | NJ 511 | |
| NISSAN | Bus RM | Rear wheel outer | 38212-Z5000 | 47*56*7 | PAYEN | NJ 400 | |
| NISSAN UD | CA18 4 cyl (ohc) 1809 cc | Cam Shaft | 13042-16A05 | 34*48*8 | PAYEN | NJ285 | 83-on |
| NISSAN | CA20 4 cyl (ohc) | Timing Cover | 13510-D0100 | 33*47*8 | PAYEN | NJ280 | 84-on |
| NISSAN UD | CA20 4 cyl (ohc) 1974 cc | Cam Shaft | 13042-D0101 | 34*48*8 | PAYEN | NJ285 | 84- on |
| NISSAN UD | CA20 4 cyl (ohc) 1974 cc | Cam Shaft | 13042-D0100 | 34*48*8 | PAYEN | NJ285 | 84- on |
| NISSAN UD | CA20 4 cyl (ohc) 1974 cc | Crank Shaft Rear | 12279-D0100 | 84*104*11 | PAYEN | NJ284 | 84-on |
| NISSAN | Caball C240 ALL | Front wheel | 40227-J5110 | 60*82*7 | PAYEN | NJ 510 | |
| NISSAN | Caball C340 ALL | Rear wheel outer | 43252-J2000 | 38*47*10 | PAYEN | NJ 513 | |
| NISSAN UD | Caball-Clipper-C240,C340 | Wheel Hub Front | | 60*82*7 | MUSASHI | N2154 | '73~'83.7 |
| NISSAN UD | Cabstar ED33 4 CYL Diesel 3298 cc | Crank Shaft Rear | 12278-T9001 | 105*135*12.5 | PAYEN | NJ 372 | |
| NISSAN | Cabstar F20 ALL | Front wheel | 26134-6401P | 57*73*7 | PAYEN | NJ 545 | |
| NISSAN | Cabstar F20 ALL | Steering sector | 48040-84500 | 32*43*7 | PAYEN | NJ 642 | |
| NISSAN UD | Cabstar F20 F20...flat | | 43152-82100 | 80*105*13 | PAYEN | NJ 512 | |
| NISSAN UD | Cabstar F20 F20...J15.J16 | Rear wheel outer | 43232-B5000 | 50*67*11 | PAYEN | NJ 387 | |
| NISSAN UD | Cabstar-Homer-H20 | Engine Crank Shaft Front | | 45*68*12 | MUSASHI | N2030 | '76.1~'81.12 |
| NISSAN UD | Caravan Homy UrvanE24...VG30E | Engine Crank Shaft Rear | | 84*104*11 | MUSASHI | N2211 | '88.10~'89.2 |
| NISSAN | Cedric Y30 ALL | Front wheel | 40232-B9500 | 54*65*13 | PAYEN | NJ 386 | |
| NISSAN | Cedric Y30 ALL | Rear wheel | 38212-73000 | 35*55*11 | PAYEN | NJ 274 | |
| NISSAN | Cedric Y30 ALL | Steering sector | 48040-82100 | 35*48*8 | PAYEN | NJ 415 | |
| NISSAN | Cedric Y31 ALL | Steering Worm | 48029-W0501 | 17.5*32*7 | PAYEN | NK 109 | |
| NISSAN UD | CEFIOR(FWD)-A32...Except VQ30DE.TRIG | Transmission & Differential Mission Case | | 39*59*11/17 | MUSASHI | N2249 | '94.8~ |
| NISSAN UD | CEFIOR(FWD)-A32...MT | Transmission & Differential Clutch Housing | | 33*59*11/17 | MUSASHI | N2250 | '94.8~ |
| NISSAN UD | Cefiro(RWD)-A31...RB20# | Engine Crank Shaft Front | | 40*52*7 | MUSASHI | N2266 | '88.9~'94 |
| NISSAN UD | Cefiro(RWD)-A31...RB20E | Final Drive Diff. Side | 38342-21000 | 32*52*11/15.5 | MUSASHI | N2087 | '90.8~'94 |
| NISSAN UD | Cherry A14 4 CYL (OHV) 1397 cc | Crank Shaft Rear | 12279-H2300/01 | 60*82*12 | PAYEN | NJ 004 | |
| NISSAN | Cherry F10 ALL | Steering gear | 48125-78500 | 17*35*8.5 | PAYEN | NJ653 | |
| NISSAN | Cherry F10 | Front wheel outer | 40232-M5600/10/11 | 52*67*7 | PAYEN | NJ 552 | |
| NISSAN | Civilian Bus W40 | Rear wheel innerr | 43252-82100 | 80*105*13 | PAYEN | NJ 512 | |
| NISSAN | Civilian-W40 | Wheel Hub Front | | 60*82*7 | MUSASHI | N2154 | '82.8~'93.4 |
| NISSAN UD | Civilian-W40...FD33T,TD42 | Final Drive Pinion | 38189-61500 | 56*72*9 | MUSASHI | N2070 | '84.6~'91.10 |
| NISSAN | CK10 | Rear Wheel Inner | 43090-58000 | 95*135*13 | PAYEN | NJ601 | 70-79 |

| CAR | MODEL | APPLICATION | OEM NO. | SIZE | DATA acc. | CODE | YEARS |
|-----------|---|-----------------------------|-------------------|---------------|-----------|--------|-------------|
| NISSAN UD | Condor Truck(3.5t ~ 7t)-FD6...CM86 | Engine Crank Shaft Front | 12278-Z5500 | 60*82*12 | MUSASHI | ※ | '83.5~'86 |
| NISSAN UD | Condor Truck(3.5t~7t) | Engine Crank Shaft Front | | 62*85/93*13 | MUSASHI | N2168 | '74.9~'83 |
| NISSAN UD | Condor Truck(3.5t~7t) | Engine Crank Shaft Rear | | 120*145*10 | MUSASHI | | '93.1~ |
| NISSAN UD | Datsun Truck-620,720 | Wheel Hub Rear Outer | 43232-B5000 | 50*67*11 | MUSASHI | N2119 | '72~'85 |
| NISSAN UD | Datsun Truck-620,720...J15,J16 | Engine Crank Shaft Front | | 39.7*62*11 | MUSASHI | N2023 | '72~'81.12 |
| NISSAN UD | Datsun Truck-720...4WD | Wheel Hub Front Drive Shaft | | 50*72/83*16.2 | MUSASHI | N2232 | '83.4~'85 |
| NISSAN UD | Datsun Truck-D21 | Steering Sector Shaft | | 34*44*8 | MUSASHI | ※ | '92.8~ |
| NISSAN UD | Datsun Truck-D21 | Steering Worm | | 18*30*8 | MUSASHI | N2314 | '92.8~ |
| NISSAN UD | Datsun Truck-D21 | Wheel Hub Rear Outer | | 50*70*12/17 | MUSASHI | N2223 | '85.8~ |
| NISSAN UD | Datsun Truck-D21...4WD | Wheel Hub Front | 40232-31G00 | 57*79*9/13.5 | MUSASHI | N2251 | '85.8~ |
| NISSAN UD | Datsun Truck-D21...CA# Final | Final Drive Pinion (Rear) | | 40*75*12/17.5 | MUSASHI | N2061 | '85.8~'91.7 |
| NISSAN UD | E13 4 cyl (ohc) 1270 cc | Timing Cover | 13510-01M00 | 36*49*7 | PAYEN | NJ286 | 83- on |
| NISSAN UD | E15 4 cyl (ohc) 1488 cc | Crank Shaft Rear | 12279-T7200 | 80*100*10 | PAYEN | NJ287 | 84-on |
| NISSAN UD | ED30 4 cyl Diesel 2956 cc | Timing Cover | 12278-90016 | 62*85/93*13 | PAYEN | NJ227 | 73-on |
| NISSAN UD | ED33 4 cyl Diesel 3298 cc | Timing Cover | 12278-T9000 | 62*85*12.5 | PAYEN | NJ371 | 11/81-11/86 |
| NISSAN UD | EXA-KN13...Drum Brake | Wheel Hub Rear | 43232-50A00 | 40*52*6/10 | MUSASHI | N2240 | '88.5~'90 |
| NISSAN UD | F20 except flat low(H20.SD22) | Rear Wheel Inner | 09061-0001P | 68*82*7 | PAYEN | NJ828 | 1/76-12/81 |
| NISSAN UD | Fairlady S130 ALL | Transmission rear | 32136-X0101 | 35*50*11 | PAYEN | NJ 080 | |
| NISSAN UD | Fairlady S130 S130...2000 cc(except turbo).2800cc(AT) | Differential pinion | 38189-U3000 | 35*67*12/18 | PAYEN | NJ 575 | |
| NISSAN UD | Fairlady S130 S130...2000cc(except) | Differential side | 38342-21000 | 32*52*11/15.5 | PAYEN | NJ 117 | |
| NISSAN UD | Fairlady S130 S130...2000cc(turbo).2800cc(MT) | | 38342-N3100 | 33*59*11/17 | PAYEN | NJ 147 | |
| NISSAN UD | Fairlady Z31 ALL | Front wheel | 40232-N7100 | 46*59.1*12/13 | PAYEN | NJ 107 | |
| NISSAN UD | Fork Lift A12 4 CYL (OHV) 1171 cc | Crank Shaft Rear | 12279-18000/01/10 | 60*82*12 | PAYEN | NJ 021 | |
| NISSAN UD | Fork Lift J15 4 CYL (OHV) 1483 cc | Timing Cover | 13042-B3000/L1600 | 39.7*62*11 | PAYEN | NJ 050 | |
| NISSAN UD | Fork Lift SD25 4 CYL Diesel 2488 cc | Crank Shaft Rear | 12279-01M00/42L00 | 80*100*10 | PAYEN | NJ 287 | |
| NISSAN UD | Homer F20 F20...RS5W81A.R4 W81A | Transmission rear | 32136-J2000/6500 | 40*62*11 | PAYEN | NJ 414 | |
| NISSAN UD | J15 4 cyl (ohv) 1483 cc | Timing Cover | 13042-B3000 | 39.7*62*11 | PAYEN | NJ050 | 76-9/79 |
| NISSAN UD | Junior 140 140...except N140 | Differential pinion | 38189-31300/J2000 | 42*72.5*12 | PAYEN | NJ 508 | |
| NISSAN UD | Junior 140 140...except N140 | Rear wheel inner | 43223-30100 | 74*95*7 | PAYEN | NJ 555 | |
| NISSAN UD | Junior-140 | Wheel Hub Front | | 54*65*13 | MUSASHI | N2101 | '78.4~ |

| CAR | MODEL | APPLICATION | OEM NO. | SIZE | DATA acc. | CODE | YEARS |
|--------------|---|--|--------------------------|----------------|-----------|--------|---------------|
| NISSAN | Junior-140 | Wheel Hub Front | | 57*73*7 | MUSASHI | N2034 | '70.10~'78.3 |
| NISSAN UD | Junior-140...Except N140 | Final Drive Pinion | 38189-J2000 | 42*72.5*12 | MUSASHI | N2060 | '70.10~ |
| NISSAN UD | Junior-140...Except N140 | Wheel Hub Rear Inner | | 74*95*7 | MUSASHI | N2118 | '70.10~'78.3 |
| NISSAN UD | KA24E 4 cyl (ohc) 2389 cc | Timing Cover | 13510-40F00 | 46*58*7 | PAYEN | NK106 | 89-90 |
| NISSAN UD | L13 4 cyl (ohc) 1296 cc | Timing Cover | 13042-73000 | 48*70*9 | PAYEN | NJ045 | 68-81 |
| NISSAN UD | L14 4 cyl (ohc) 1428 cc | Crank Shaft Rear | 12279-A4600 | 80*100*13 | PAYEN | NJ056 | 68-81 |
| NISSAN UD | L14 4 cyl (ohc) 1428 cc | Timing Cover | 13042-A3510 | 48*70*9 | PAYEN | NJ045 | 68-81 |
| NISSAN UD | L14 4 cyl (ohc) 1428 cc | Timing Cover | 13042-A3500 | 48*70*9 | PAYEN | NJ045 | 68-81 |
| NISSAN UD | L16 4 cyl (ohc) 1595 cc | Crank Shaft Rear | 12279-R4610 | 80*100*13 | PAYEN | NJ056 | 68-81 |
| NISSAN UD | L16 4 cyl (ohc) 1595 cc | Crank Shaft Rear | 12279-R4611 | 80*100*13 | PAYEN | NJ056 | 68-81 |
| NISSAN UD | L16 4 cyl (ohc) 1595 cc | Timing Cover | 13042-A8600 | 48*70*9 | PAYEN | NJ045 | 68-81 |
| NISSAN | Laurel C31 ALL | Transmission rear | 33136-X0101 | 35*50*11 | PAYEN | NJ 080 | |
| NISSAN UD | Laurel C32 C32...CA18#.RB20E .LD28.RD28 | Rear wheel | 43252-18000 | 41*56*7 | PAYEN | NJ 036 | |
| NISSAN UD | Laurel L18 4 CYL (OHC) 1770 cc | | 12279-21000/10 | 80*100*13 | PAYEN | NJ 056 | |
| NISSAN | March K10 ALL | Rear wheel | 43252-01B00 | 38*50.3*10 | PAYEN | NJ 553 | |
| NISSAN UD | March K10 ALL...w/o turbo | Differential side | 38342-01B00 | 38*58*11/17 | PAYEN | NJ 687 | |
| NISSAN UD | March- K10...MA10#,MA09 RT | Engine Crank Shaft Rear | | 75*94*10 | MUSASHI | N2263 | '82.10~'92 |
| NISSAN UD | March-K11 | Wheel Hub Front Grease Seal | 04422-20010, 40232-21B00 | 52*68*7.5/12 | MUSASHI | N2260 | '92.1~ |
| NISSAN UD | March-K11...1000cc | Transmission & Differential Mission Case | | 38*58*11/17 | MUSASHI | N2246 | '92.1~ |
| NISSAN UD | Micra MA12 4 CYL (OHC) 1235 cc | Crank Shaft Rear | 12279-01B00/11 | 75*94*10 | PAYEN | NJ 364 | |
| NISSAN UD | ND6 6 cyl Diesel 6842 cc | Crank Shaft Rear | 12279-95000/04 | 120*140/146*13 | PAYEN | NJ 110 | 69-on |
| NISSAN | P 6 cyl (ohv) 3956 | Timing Cover | 13043-43700 | 50*72*12 | PAYEN | NJ291 | |
| NISSAN UD | Pathfinder TD27 4 CYL (OHV) 2663 cc | Crank Shaft Rear | 12279-43G00 | 86*100*10 | PAYEN | NJ 829 | |
| NISSAN UD | Pathfinder VG30 V6 CYL (OHC) 2960 cc | Crank Shaft Rear | 12279-18V00/77A10 | 84*104*11 | PAYEN | NJ 284 | |
| NISSAN UD | Patrol 160 160...F4W81A | Transfer case | 33111-C6200 | 45*68*12 | PAYEN | NJ 450 | |
| NISSAN UD | Patrol-160 | Wheel Hub Front Dust Seal | | 65*88*11/16.5 | MUSASHI | N2165 | '80.6~'83.4 |
| NISSAN UD | Patrol-160...SD33# | Engine Crank Shaft Front | | 58*80*12 | MUSASHI | N2028 | '80.6~'87 |
| NISSAN UD | Patrol- Y60...TB42#,TD42 | Engine Crank Shaft Rear | 12279-43G00 | 86*100*10 | MUSASHI | N2256 | '87.10~ |
| NISSAN UD | Patrol- Y60...TD42#,TB42E .RD28T | Final Drive Pinion (Rear) | 09062-0020P | 42*76*12/21 | MUSASHI | N2007 | '87.10~'91.10 |
| NISSAN | Pick up 620 ALL | Front wheel | 40227-73000 | 48*65*10 | PAYEN | NJ 081 | |
| NISSAN UD | Pick up 720 720...4WD | | 40227-50W00/01 | 50*72/83*16.2 | PAYEN | NJ 836 | |

| CAR | MODEL | APPLICATION | OEM NO. | SIZE | DATA acc. | CODE | YEARS |
|-----------|--|--|-------------------|----------------|-----------|--------|------------|
| NISSAN UD | Pick up D21 D21...2WD | Front wheel | 40232-01G00/10 | 54*75.5*12/18 | PAYEN | NJ 750 | |
| NISSAN UD | Pick up D21 D21...2WD | Transmission rear | 31336-X0101 | 35*50*11 | PAYEN | NJ 080 | |
| NISSAN UD | Pick up D21 D21...4WD | | 40232-31G00 | 57*79*9/13.5 | PAYEN | NJ 695 | |
| NISSAN UD | Pick up DS23 4 CYL Diesel 2289 cc | | 13043-76200/T7200 | 58*80*12 | PAYEN | NJ 369 | |
| NISSAN UD | Prairie M10 M10...2WD | Rear wheel | 43252-M7000/01 | 42*54*8 | PAYEN | NJ 419 | |
| NISSAN UD | Prairie M10 M10...CA20 | Differential | 38342-06R00 | 52*72*9 | PAYEN | NJ 658 | |
| NISSAN UD | Pulsar- N10,N12,N13...E13 E15 | Engine Jack Shaft | | 32*50*8 | MUSASHI | N2189 | '81.3~'88 |
| NISSAN UD | Pulsar- N10,N12,N13...E13, E15 | Engine Crank Shaft Front | | 36*49*7 | MUSASHI | N2186 | '81.3~'88 |
| NISSAN UD | Pulsar- N12,N13,N14...CD1 | Engine Cam Shaft | | 34*48*8 | MUSASHI | N2212 | '83.5~'95 |
| NISSAN UD | Pulsar- N14,N15...SR18DE, SR20DET | Engine Crank Shaft Front | | 46*58*7 | MUSASHI | N2293 | '90.8~ |
| NISSAN UD | R 4 cyl (ohv) 1595 | Timing Cover | 13510-E0700 | 45*68*12 | PAYEN | NJ278 | 64-68 |
| NISSAN UD | R 4 cyl (ohv) 1595 | Timing Cover | 13042-32200 | 45*68*12 | PAYEN | NJ278 | 64-68 |
| NISSAN UD | RASHEEN- RB14...AT | Transmission & Differential Mission Case | | 40*56*8/13.5 | MUSASHI | N2283 | '94.12~ |
| NISSAN UD | RD28T 6 cyl Diesel 2825 cc | Crank Shaft Rear | 12279-T7201 | 80*100*10 | PAYEN | NJ287 | 8/92-on |
| NISSAN UD | RD28T 6 cyl Diesel 2825 cc | Crank Shaft Rear | 12279-T7202 | 80*100*10 | PAYEN | NJ287 | 8/92-on |
| NISSAN UD | RD28T 6 cyl Diesel 2825 cc | Timing Cover | 13510-77A10 | 40*52*7 | PAYEN | NJ765 | 8/92-on |
| NISSAN UD | RD28T 6 cyl Diesel 2825 cc | Timing Cover | 13510-V7200 | 40*52*7 | PAYEN | NJ765 | 8/92-on |
| NISSAN UD | RD28T 6 cyl Diesel 2825 cc | Timing Cover | 13510-19V00 | 40*52*7 | PAYEN | NJ765 | 8/92-on |
| NISSAN UD | RD28T 6 cyl Diesel 2825 cc | Timing Cover | 13510-42L00 | 40*52*7 | PAYEN | NJ765 | 8/92-on |
| NISSAN UD | SD22 4 cyl Diesel 2164 cc | Timing Cover | 13042-76200 | 58*80*12 | PAYEN | NJ369 | 70-3/81 |
| NISSAN UD | SENTRA GA16D 4 CYL (DOHC) 1597 | | 13276-53Y00/10/11 | 27*49*7.5 | PAYEN | NJ 207 | |
| NISSAN UD | Silvia KA24D 4 CYL (DOHC) 2389 cc | Timing Cover | 13510-40F00/10 | 46*58*7 | PAYEN | NK106 | |
| NISSAN UD | Silvia-S10,S11 | Transmission Front Cover | | 34*50*7 | MUSASHI | N2037 | '75.10~'79 |
| NISSAN UD | Silvia- S10,S11,S110,S12, S13,S14 | Transmission Rear Extension | | 35*50*11 | MUSASHI | N2045 | '75.10~ |
| NISSAN UD | Silvia- S12...CA18S,CA18 | Wheel Hub Rear | 43232-H1000 | 41*56*7 | MUSASHI | N2125 | '83.8~'88 |
| NISSAN UD | Skyline R31 | Differential | 38189-N3100 | 40*75*12/17 | PAYEN | NJ 441 | |
| NISSAN UD | Skyline R31 | Differential side | 39342-N3100 | 33*59*11/17 | PAYEN | NJ 147 | |
| NISSAN UD | Skyline R31 | | 38189-N3100 | 40*75*12/17.5 | PAYEN | NJ 441 | |
| NISSAN UD | Skyline RB20 6 CYL (OHC) 1998 cc | Cam Shaft | 13042-16V00/42L00 | 40*52*7 | PAYEN | NJ 765 | |
| NISSAN UD | Stanza A1# A10.11...FS5W60A. F4W60 | Transmission Rear | 32136-H5000/H8900 | 30*45/62*15/41 | PAYEN | NJ 685 | |

| CAR | MODEL | APPLICATION | OEM NO. | SIZE | DATA acc. | CODE | YEARS |
|-----------|---|--|-------------------|-----------------|-----------|--------|------------|
| NISSAN UD | Stanza CA16 4 CYL (OHC) 1598 cc | Timing Cover | 13510-16A00/16V10 | 33*47*8 | PAYEN | NJ 280 | |
| NISSAN UD | Stanza(RWD)-A10,A11...DiscBrak | Wheel Hub Front | | 42*55*8 | MUSASHI | N2110 | '77.5~'81 |
| NISSAN | Sunny B210 ALL | Transmission rear | 32136-G1000/01 | 30*45/62*15/41 | PAYEN | NJ 085 | |
| NISSAN | Sunny B310 ALL | Steering Worm | 49029-H5000 | 17*30*7 | PAYEN | NJ 621 | |
| NISSAN | Sunny B310 ALL | Steering Worm | 49029-H5000 | 17*30*7 | PAYEN | NJ 621 | |
| NISSAN UD | Sunny B310 B310...F4W56A | Transmission Front | 3211313200/H3100 | 24*40*8 | PAYEN | NJ 084 | |
| NISSAN UD | Sunny(FWD)-B11 | Transmission & Differential Clutch Housing | 38342-M8001 | 40*56*8 | MUSASHI | N2195 | '81.10~'85 |
| NISSAN UD | Sunny(FWD)-B11...E15S,CD17 | Wheel Hub Front Dust Seal | 40227-M5601/05 | 52*68*13 | MUSASHI | N2091 | '81.10~'85 |
| NISSAN UD | Truck & Bus ND6 6 CYL Diesel 6842 cc | | 12278-90006 | 62*85/93*13 | PAYEN | NJ 224 | |
| NISSAN | Truck CD ALL | Rear wheel outer | 38212-90003/05 | 60*72*7.5 | PAYEN | NJ 389 | |
| NISSAN | Truck CK CK10 | Differential pinion | 32136-53000 | 63.5*85*12 | PAYEN | NJ 604 | |
| NISSAN | Truck CK CK10 | Rear Wheel Inner | 43090-90016 | 95*135*13 | PAYEN | NJ601 | 70-79 |
| NISSAN | Truck CK CK10 | Rear wheel inner | 43909-58000/90016 | 95*135*13 | PAYEN | NJ 601 | |
| NISSAN | Truck CK CK10 | Transmission rear | 32136-C0400 | 55*70*9 | PAYEN | NJ 603 | |
| NISSAN | Truck CK CK85 | Front Wheel | 40232-C0400 | 85*111*10 | PAYEN | NJ 613 | |
| NISSAN | Truck CL | Rear Shaft Inner | 43090-Z5001 | 127*146*10 | PAYEN | NJ 755 | |
| NISSAN UD | Truck CM CM80.85.86.90 | Transmission | 32136-Z5000/01/02 | 58*75*9 | PAYEN | NJ 297 | |
| NISSAN | Truck CP | Rear wheel outer | 38212-90003/06 | 60*72*7.5 | PAYEN | NJ 389 | |
| NISSAN UD | Truck CW CW50...chassis no. 030947- | | 38189-90101/05 | 105*135*14/20.5 | PAYEN | NJ 686 | |
| NISSAN UD | Truck TK TK20GD.GM.LC...c hassis no.-010497 | Differential pinion | 38189-90007 | 85*125*14 | PAYEN | NJ 507 | |
| NISSAN UD | UD Bus | Engine Crank Shaft Rear | 12279-Z5503 | 110*135*9 | MUSASHI | N2319 | '84~ |
| NISSAN UD | UD Bus | Engine Crank Shaft Rear | | 133*157*14 | MUSASHI | N2325 | '88~'86 |
| NISSAN | UD Truck Engin | Crank Shaft Front | | 62*85*12 | MUSASHI | | '89~ |
| NISSAN | UD Truck Engin | Crank Shaft Rear | | 138*162*14 | MUSASHI | | '89~ |
| NISSAN UD | UD Truck Engin-RE10...E/# 000552~ | Crank Shaft Rear | | 132*150/156*14 | MUSASHI | ※ | '85~'86.1 |
| NISSAN | Vanette C120 ALL | Steering sector | 48137-H1000/01/02 | 25*38*7 | PAYEN | NJ 118 | |
| NISSAN UD | Vanette C120 C120...long body Truck | Rear wheel outer | 43252-G3200 | 25*35*7 | PAYEN | NJ 830 | |
| NISSAN UD | Vanette C120 C120...van | Transmission Front | 32213-13200/H3100 | 24*40*8 | PAYEN | NJ 084 | |
| NISSAN UD | Vanette Truck-C120....Drum Brake | Wheel Hub Front | 40232-N7100 | 46*59.1*12/13 | MUSASHI | N2107 | '78.10~'82 |
| NISSAN UD | Vanette Truck-TC22 | Steering Sector Shaft | | 28.6*40*8 | MUSASHI | ※ | '88.11~ |
| NISSAN UD | Vanette(Serena) Coach,VAN-C23...2WD | Wheel Hub Front | | 56*76*6/12 | MUSASHI | N2274 | '91.6~ |
| NISSAN | Violet T12 ALL | Rear wheel | 43252-03E00/01 | 43*54*6 | PAYEN | NJ 844 | |
| NISSAN | | | 12270-97002 | 132*150/156*14 | PAYEN | NK111 | |
| NISSAN | | | 32867-E3200 | 17*27/33*10.3 | PAYEN | NJ954 | |
| NISSAN | | | 48137-61500 | 22*35*8 | PAYEN | NJ632 | |
| NISSAN | | | 13168-01M00 | 32*50*8 | PAYEN | NJ951 | |
| NISSAN | | | 48068-90000 | 38*58*11 | PAYEN | NK085 | |
| NISSAN | | | 38189-90060 | 63.5*85*12 | PAYEN | NJ834 | |
| NISSAN | | | 43232-11G00 | 65*90/97*11 | PAYEN | NJ146 | |

| CAR | MODEL | APPLICATION | OEM NO. | SIZE | DATA acc. | CODE | YEARS |
|------------------|-------------------------------|--|-------------------------|-----------------|-----------|--------|------------|
| NISSAN | | | 32136-90015 | 80*105*13 | PAYEN | NK059 | |
| NISSAN | ALL | Rear Wheel Inner | 38212-P4500 | 35*55*11 | PAYEN | NJ274 | 8/80-8/86 |
| NISSAN | ALL | Transmission | 32336-E0100 | 35*50*11 | PAYEN | NJ080 | 11/75-7/80 |
| NISSAN | ALL | Transmission | 32136-07200 | 35*50*11 | PAYEN | NJ080 | 3/79-7/83 |
| NISSAN UD | CA16 4 cyl (dohc) 1598 cc | Timing Cover | 10342-42L00 | 40*52*7 | PAYEN | NJ765 | 87-on |
| NISSAN UD | CA18 4 cyl (ohc) 1809 cc | Timing Cover | 13042-77A10 | 40*52*7 | PAYEN | NJ765 | 86-on |
| NISSAN UD | CA18 4 cyl (ohc) 1809 cc | Timing Cover | 13042-V7200 | 40*52*7 | PAYEN | NJ765 | 86-on |
| NISSAN | CK10 | Differential Dinion | 38189-50000 | 63.5*85*12 | PAYEN | NJ604 | 70-79 |
| NISSAN UD | CW50 .chassis no.030947- | Differential Dinion | 38189-90101 | 105*135*14/20.5 | PAYEN | NJ686 | 77 |
| NISSAN UD | CW50 .chassis no.030947- | Differential Dinion | 38189-90105 | 105*135*14/20.5 | PAYEN | NJ686 | 77 |
| NISSAN UD | FJ20 4 cyl (dohc) 1990 cc | Crank Shaft Rear | 12279-V1700 | 80*100*10 | PAYEN | NJ287 | 82-84 |
| NISSAN | KP3#.50 | Differential Dinion | 90311-35131 | 35*55*11 | PAYEN | NJ607 | 4/69-on |
| NISSAN UD | U12 2WD(SR18DI) | Differential transmission side | 383432-31X00 | 40*56*8/13.5 | PAYEN | NJ190 | 10/89-on |
| NISSAN | Maxima-J30...VG30E | Transmission & Differential Mission Case | | 39*57*11/17 | MUSASHI | N2291 | 88.10~91.8 |
| NISSAN | 810 R160.R180 | Differential Dinion | 38189-U3000/38332-21100 | 35*67*12/18 | PAYEN | NJ575 | 5/88-on |
| NISSAN UD | Sunny B310 ALL | Steering Worm | 48029-H5000 | 17*30*7 | PAYEN | NJ 621 | |
| NISSANDI ESEL UD | Condor | Transmission Rear | 32136-X5000 | 58*75*9 | MUSASHI | | |
| NISSANDI ESEL UD | UD | Transmission Rear | 32136-90017 | 70*88*12 | MUSASHI | | |
| NISSANE1 | Sunny | Crank Shaft Rear | 1227901M00 | 80*100*10 | MUSASHI | | |
| Nissan | ALL | Rear Wheel | 43232-78100 | 35*55*11 | PAYEN | NJ274 | 6/83-12/87 |
| MITSUBIS HI | 4D65T 4 cyl Diesel 1795 cc | Crank Shaft Rear | MD069947 | 80*96*9 | PAYEN | NJ251 | 5/85-8/87 |
| MITSUBIS HI | 4G12 4 cyl (ohc) 1410 cc | Timing Cover | MD153104 | 30*46*7 | PAYEN | NJ252 | 79-86 |
| MITSUBIS HI | 4G12 4 cyl (ohc) 1410 cc | Timing Cover | 21421-21010 | 30*46*7 | PAYEN | NJ252 | 79-86 |
| MITSUBIS HI | 4G32 4 cyl (ohc) 1597 cc | Crank Shaft Rear | 21443-21010 | 72*96*9 | PAYEN | NJ006 | 77 |
| MITSUBIS HI | 4G32 4 cyl (ohc) 1597 cc | Crank Shaft Rear | MD016549 | 72*96*9 | PAYEN | NJ006 | 77 |
| MITSUBIS HI | 4G32 4 cyl (ohc) 1597 cc | Crank Shaft Rear | MD008885 | 72*96*9 | PAYEN | NJ006 | 77 |
| MITSUBIS HI | 4G32 4 cyl (ohc) 1597 cc | Crank Shaft Rear | MD000248 | 72*96*9 | PAYEN | NJ008 | 76 |
| MITSUBIS HI | 4G32 4 cyl (ohc) 1597 cc | Timing Cover | MD069949 | 44*60*7 | PAYEN | NJ005 | 77 |
| MITSUBIS HI | 4G32 4 cyl (ohc) 1597 cc | Timing Cover | MD000254 | 44*65*11 | PAYEN | NJ007 | 76-9/77 |
| MITSUBIS HI | 4G33 4 cyl (ohc) 1439 cc | Cam Shaft | MD016310 | 35*50*8 | PAYEN | NJ242 | 8/77-84 |
| MITSUBIS HI | 4G33 4 cyl (ohc) 1439 cc | Cam Shaft | MD008762 | 35*50*8 | PAYEN | NJ242 | 8/77-84 |
| MITSUBIS HI | 4G33 4 cyl (ohc) 1439 cc | Oil Pump | MD069948 | 17*28*7 | PAYEN | NJ255 | 8/77-84 |
| MITSUBIS HI | 6G72 V6 cyl (ohc) 2972 cc | Crank Shaft Rear | MD-101915 | 91*111*9 | PAYEN | NJ873 | 87- on |
| MITSUBIS | A121A.122A.123A | Differential Dinion | MB-001170 | 35*65*12 | PAYEN | NJ024 | 6/76-77 |
| MITSUBIS | A121V.A123V. | Differential Dinion | MB160578 | 42*65*12 | PAYEN | NJ823 | 11/77-81 |
| MITSUBIS | A121V.A123V. | Differential Dinion | MB092296 | 42*65*12 | PAYEN | NJ823 | 11/77-81 |
| MITSUBIS | A131A | Rear Wheel | MT141546 | 42*55*9 | PAYEN | NJ023 | 11/77-80 |
| MITSUBIS | A162A NTX(turbo) | Transmission | MD723202 | 30*45*6 | PAYEN | NJ611 | 10/82-83 |
| MITSUBIS | A215G BHZ3 | Front Wheel | MB303875 | 52*72*8/11 | PAYEN | NJ825 | 10/85-87 |

| CAR | MODEL | APPLICATION | OEM NO. | SIZE | DATA acc. | CODE | YEARS |
|-------------|----------------------------------|-------------------------|--------------------|-----------------|-----------|--------|------------|
| MITSUBIS HI | A221A.212A.213A.215A. | Front Wheel | MB176746 | 50*66.5*13/15.5 | PAYEN | NJ538 | 10/84-87 |
| MITSUBIS HI | A221A.212A.213A.215A. | Front Wheel | MB109057 | 50*66.5*13/15.5 | PAYEN | NJ538 | 10/84-87 |
| MITSUBIS HI | A221A.212A.213A.215A. | Front Wheel | 51713-21100 | 50*66.5*13/15.5 | PAYEN | NJ538 | 3/82-87 |
| MITSUBIS | ALL | Front Wheel | 03434-08900 | 102*116*14 | PAYEN | NJ4 99 | 7/74-on |
| MITSUBIS | ALL | Front Wheel | MH034085 | 102*116*14 | PAYEN | NJ499 | 7/74-on |
| MITSUBIS | ALL | Front Wheel | MH034012 | 102*116*14 | PAYEN | NJ499 | 7/74-on |
| MITSUBIS | ALL | Front Wheel | MH034091 | 102*116*14 | PAYEN | NJ499 | 7/74-on |
| MITSUBIS | ALL | Front Wheel | 03434-12101 | 125*150*14 | PAYEN | NJ 950 | 2/74-on |
| MITSUBIS | ALL | Front Wheel | 03434-12100 | 125*150*14 | PAYEN | NJ 950 | 2/74-on |
| MITSUBIS | ALL | Front Wheel | MH034086 | 125*150*14 | PAYEN | NJ950 | 2/74-on |
| MITSUBIS | ALL | Rear Wheel Inner | MH034092 | 130*150*14 | PAYEN | NJ543 | 7/74-on |
| MITSUBIS | ALL | Rear Wheel Inner | MH034047 | 130*150*14 | PAYEN | NJ543 | 7/74-on |
| MITSUBIS | ALL | Rear Wheel Inner | 03434-13000 | 130*150*14 | PAYEN | NJ543 | 7/74-on |
| MITSUBIS | ALL | Rear Wheel Inner | MH034087 | 130*150*14 | PAYEN | NJ543 | 7/74-on |
| MITSUBIS | ALL | Rear Wheel Inner | 03434-15601 | 155*180*17 | PAYEN | NJ489 | 8/74-84 |
| MITSUBIS | ALL | Rear Wheel Inner | MH034082 | 155*180*17 | PAYEN | NJ489 | 8/74-84 |
| MITSUBIS | ALL | Rear Wheel Inner | MH034081 | 155*180*17 | PAYEN | NJ489 | 8/74-84 |
| MITSUBIS | ALL | Rear Wheel Outer | 03442-13000 | 65*120.5*10 | PAYEN | NJ498 | 7/74-6/86 |
| MITSUBIS | ALL | Rear Wheel Outer | MH034006 | 65*120.5*10 | PAYEN | NJ498 | 7/74-6/86 |
| MITSUBIS | ALL | Rear Wheel Outer | MH034078 | 65*120.5*10 | PAYEN | NJ498 | 7/74-6/86 |
| MITSUBIS | ALL | Rear Wheel Outer | MH034083 | 65*120.5*10 | PAYEN | NJ498 | 7/74-6/86 |
| MITSUBIS | ALL | Transmission | ME624211 | 34*50*7 | PAYEN | NJ396 | 7/74-79 |
| MITSUBIS | ALL | Transmission | MH034052 | 45*60*9 | PAYEN | NJ431 | 7/77-10/79 |
| MITSUBIS | ALL | Transmission | MH034036 | 55*72*9 | PAYEN | NJ461 | 7/74-79 |
| MITSUBIS | ALL except 729 | Transmission | 44414-59781 | 70*92*12 | PAYEN | NJ233 | 6/75-on |
| MITSUBIS HI | Bus 6DS3 6 CYL Diesel 5103 cc | Crank Shaft Rear | ME023152/031548 | 100*125*12.5 | PAYEN | NJ 497 | |
| MITSUBIS HI | Bus 6DS3 6 CYL Diesel 5103 cc | Timing Cover | ME024156/MH034027 | 55*78*12 | PAYEN | NJ 258 | |
| MITSUBIS HI | Bus 6DS3 6 CYL Diesel 5103 cc | Timing Cover | ME024156/MH034027 | 55*78*12 | PAYEN | NJ 258 | |
| MITSUBIS | Bus MM ALL | Rear wheel inner | 03434-15600/01/02 | 155*180*17 | PAYEN | NJ 489 | |
| MITSUBIS | Bus MM ALL | Transmission | ME620713/622400 | 34*50*7 | PAYEN | NJ 396 | |
| MITSUBIS | Bus MS ALL | Transmission | 44514-51600/01/81 | 45*60*9 | PAYEN | NJ 431 | |
| MITSUBIS | Bus MU ALL | Rear wheel inner | MC807438 | 154*172*14 | PAYEN | NJ 717 | |
| MITSUBIS | C5#.6# | Rear Wheel | MB584601 | 39*52*6/11.5 | PAYEN | NJ748 | 9/87-on |
| MITSUBIS HI | Canter 4D30 4 CYL Diesel 3298 cc | Crank Shaft Rear | ME011731/32/54 | 100*120*16 | PAYEN | NJ 411 | |
| MITSUBIS HI | Canter 4DR5 4 CYL Diesel 2659 cc | | 31311-06100/01 | 48*70*12 | PAYEN | NJ 042 | |
| MITSUBIS | Canter FB,FE,FG | Rear wheel inner | MB161153 | 74*100*10 | PAYEN | NJ 135 | |
| MITSUBIS | Canter FB,FE,FG | Steering shaft | MB162864 | 22*35*8 | PAYEN | NJ 632 | |
| MITSUBIS HI | CELEDTE 4G32 4 CYL (OHC) 1597 cc | Timing Cover | K411140-0/3 | 44*65*11 | PAYEN | NJ 007 | |
| MITSUBIS HI | Colt G32B 4 CYL (OHC) 1597 cc | | MD008882/050606 | 44*60*7 | PAYEN | NJ 005 | |
| MITSUBIS HI | Cordia A12# A215G...BHZ3 | Front wheel inner | 517133600/MB303867 | 50*82*8/11 | PAYEN | NJ 824 | |
| MITSUBIS HI | Cordia G32B 4 CYL (OHC) 1597 cc | Oil Pump | MS009038/050605 | 17*28*7 | PAYEN | NJ 255 | |
| MITSUBIS | FB.FE | Transmission | MH034071 | 48*65*9 | PAYEN | NJ595 | 11/78-on |
| MITSUBIS | FB.FE | Transmission | 31707-16500 | 48*65*9 | PAYEN | NJ595 | 11/78-on |
| MITSUBIS | FB.FE | Transmission | MH034062 | 48*65*9 | PAYEN | NJ595 | 11/78-on |
| MITSUBIS | FE except 439.449 | Differential Dinion | MB-005157 | 52*84*14 | PAYEN | NJ738 | 11/78-on |
| MITSUBIS | FE111 | Front Wheel | MT119305 | 68*90*12 | PAYEN | NJ500 | 11/78-9/82 |
| MITSUBIS | FE211 CZZ.EZZ | Front Wheel | MB-025295 | 72*94*10 | PAYEN | NJ 716 | |
| MITSUBIS HI | FK416.516 L.M.S | Propeller Shaft (Front) | MH-034065 | 70*100*13 | PAYEN | NJ374 | 6/78-on |

| CAR | MODEL | APPLICATION | OEM NO. | SIZE | DATA acc. | CODE | YEARS |
|-------------|--|---------------------|--------------------|---------------|-----------|--------|---------|
| MITSUBIS HI | G11B 4 cyl (ohc) 1244 cc | Timing Cover | 21421-21030 | 30*46*7 | PAYEN | NJ252N | |
| MITSUBIS HI | G32B 4 cyl (ohc) 1597 cc | Cam Shaft | MD153103 | 35*50*8 | PAYEN | NJ242 | 78-8/81 |
| MITSUBIS HI | G54B 4 cyl (ohc) 2555 cc | Cam Shaft | MD024529 | 23*34*8 | PAYEN | NJ 334 | 81-on |
| MITSUBIS HI | G63B 4 cyl (ohc) 1997 cc | Balance shaft | MD069950 | 25*35*6 | PAYEN | NJ 610 | -0.125 |
| MITSUBIS HI | G63B 4 cyl (ohc) 1997 cc | Balance shaft | MD069950 | 25*35*6 | PAYEN | NJ 610 | -0.125 |
| MITSUBIS HI | Galant A13# A131A | Rear wheel | MA125949/MB001115 | 42*55*9 | PAYEN | NJ 023 | |
| MITSUBIS HI | Galant A16# A162A...except NTX (turbo) | | MD701430/732/782 | 32*48*10 | PAYEN | NJ 495 | |
| MITSUBIS HI | Galant A16# A163A.164A.167A | Front Wheel | MB002074/584745 | 45*62*6 | PAYEN | NJ 493 | |
| MITSUBIS HI | Galant E3# E32A.33A.35A.37A. 38A.39A | | MB-573309 | 54*82*8/11 | PAYEN | NJ 988 | |
| MITSUBIS HI | Galant G32B 4 CYL (OHC) 1597 cc | Balance shaft | MD08883 | 28*40*8 | PAYEN | NJ 373 | |
| MITSUBIS HI | L031P.34P.36P.38P .39P double tyre | Rear Wheel Inner | MB092712 | 58*75*9 | PAYEN | NJ947 | 6/79-on |
| MITSUBIS HI | L300 L06# ALL | Transmission rear | MB703743/MD703743 | 36*52*10 | PAYEN | NJ 612 | |
| MITSUBIS HI | L300 P0# ALL | Front wheel | MT141132 | 50*65*9 | PAYEN | NJ 429 | |
| MITSUBIS HI | L300 P0# P01V | Rear wheel inner | MA125991/181498 | 52*65*9 | PAYEN | NJ 068 | |
| MITSUBIS HI | L300 P0# P01V | Transmission rear | K615323-2 | 32*48*10 | PAYEN | NJ 495 | |
| MITSUBIS HI | L300 P0# P01V.02V.03W.05V | Differential pinion | MB092145/296 | 42*65*12 | PAYEN | NJ 823 | |
| MITSUBIS HI | L300 P0# P02V.03W.04W.05 V.05W | Rear wheel outer | MB001314/393719 | 45*58*9 | PAYEN | NJ 492 | |
| MITSUBIS HI | LAMBA 4G32 4 CYL (OHC) 1597 cc | Cam Shaft | 22144-21010 | 35*50*8 | PAYEN | NJ 242 | |
| MITSUBIS HI | Mirage 4D65 4 CYL Diesel 1795 cc | Crank Shaft Rear | MD020435/050604 | 80*96*9 | PAYEN | NJ 251 | |
| MITSUBIS HI | Mirage C# C11A.12A.13A.14A | | MB242812/22 | 39*52*6/11.5 | PAYEN | NJ 748 | |
| MITSUBIS HI | Mirage G12B 4 CYL (OHC) 1410 cc | | MD030782/030789 | 30*46*7 | PAYEN | NJ 252 | |
| MITSUBIS HI | NM85/110 | Crank Shaft Front | GJ7422P | 44*65*6.5/9 | NOK | | |
| MITSUBIS HI | Pajero 4D55T 4 CYL Diesel cc | Balance shaft | MD041012/050608 | 25*35*6 | PAYEN | NJ 610 | |
| MITSUBIS HI | Pajero L0# ALL | Differential pinion | MB160949 | 45*72*12/19.5 | PAYEN | NJ 739 | |
| MITSUBIS HI | Pajero L0# ALL | Rear wheel outer | MB092437 | 50*65*10 | PAYEN | NJ 539 | |
| MITSUBIS HI | Pajero L0# ALL | Transmission | MD703735/723202 | 30*45*6 | PAYEN | NJ 611 | |
| MITSUBIS HI | Rosa 4G53 4 CYL (OHC) 2348 cc | Timing Cover | MD020308 | 48*68*11 | PAYEN | NJ 057 | |
| MITSUBIS HI | Rosa BK BK215F | Transmission rear | ME624694/MF502488 | 58*75*9 | PAYEN | NJ 297 | |
| MITSUBIS HI | Starion A18# A182 | Differential pinion | MA103220/MB001170 | 35*62*12 | PAYEN | NJ 024 | |
| MITSUBIS HI | Truck 6D10 6 CYL Diesel 5974 cc | Timing Cover | ME031051/543 | 72*94*12 | PAYEN | NJ 496 | |
| MITSUBIS HI | Truck FK ALL | Rear wheel outer | 04442-13000 | 65*120.5*10 | PAYEN | NJ 498 | |
| MITSUBIS HI | Truck FK ALL...except FK416.516(L.M.S) | Propeller Shaft | MH034066 | 60*85*12 | PAYEN | NJ 981 | |
| MITSUBIS HI | Truck FM ALL | Front wheel | 03434-12100/01 | 125*150*14 | PAYEN | NJ 950 | |
| MITSUBIS HI | Truck FM | Transmission rear | 44214-03400/MH0340 | 55*72*9 | PAYEN | NJ 461 | |
| MITSUBIS HI | Truck FP ALL | Transmission rear | 03434-07001 | 70*92*12 | PAYEN | NJ 233 | |
| MITSUBIS HI | | | 03434-14500 | 145*175*14 | PAYEN | NJ618 | |
| MITSUBIS HI | | | 03434-15520 | 155*190*17 | PAYEN | NJ754 | |

| CAR | MODEL | APPLICATION | OEM NO. | SIZE | DATA acc. | CODE | YEARS |
|---------------------|--|---------------------------------|-----------------------|--------------|-----------|--------|--------------|
| MITSUBIS | | | | 19*32*5 | PAYEN | NJ715 | |
| MITSUBIS | | | MD133317 | 35*50*8 | PAYEN | NJ933 | |
| MITSUBIS | | | 52713-28000 | 39*52*6.5 | PAYEN | NJ180 | |
| MITSUBIS | | | 52713-24000 | 39*54*6 | PAYEN | NJ181 | |
| MITSUBIS | | | MD707575 | 43*60*9 | PAYEN | NK084 | |
| MITSUBIS | | | MB633432 | 60*86*7/12.5 | PAYEN | NJ136 | |
| MITSUBIS HI | DA120 6 Cyl Diesel 6126 cc | Timing Cover | 909924-5500 | 70*92*12 | PAYEN | NJ233 | 69 |
| MITSUBIS HI | KE43 4 cyl (ohv) 997 cc | Timing Cover | H411140-3 | 44*65*11 | PAYEN | NJ007 | 63-71 |
| MITSUBIS | | | 93102-20371 | 20*42*8 | | | |
| MITSUBIS | | | ME-202850 | 50*74*11 | NOK | | |
| MITSUBIS | | | MB-308966 | 56*114*10 | | | |
| MITSUBIS HI | Fuso Truck 10t~12t- FT | Rear Wheel Outer | MH-034135 | 65*77*12 | MUSASHI | F4045 | |
| MITSUBIS HI | Rosa BH BH212F.214F | Front wheel | MT-119305 | 68*90*13 | PAYEN | NJ 500 | |
| MITSUBIS | Truck FV112.113 | Propeller Shaft | MH-034065 | 70*100*10 | PAYEN | NJ 374 | |
| MITSUBIS | Bus MK ALL | Rear wheel outer | MH-034006.03442-13000 | 65*120.5*10 | PAYEN | NJ 498 | 4/76-7/85 |
| MITSUBISHI | Canter FB,FE,FG | Rear wheel inner | MB161153 | 74*100*10 | PAYEN | NJ 135 | |
| MITSUBISHI | 4G32 4 cyl (ohc) 1597 cc | Crank Shaft Rear | 21443-21000 | 72*96*9 | PAYEN | NJ008 | 76 |
| MITSUBISHI | 4G32 4 cyl (ohc) 1597 cc | Crank Shaft Rear | MD000248 | 72*96*9 | PAYEN | NJ008 | 76 |
| MITSUBISHI | 4G15 4 cyl (ohc) 1468 cc | Crank Shaft Rear | MD008885 | 72*96*9 | PAYEN | NJ006 | 5/90-on |
| MITSUBISHI | 4G32 4 cyl (ohc) 1597 cc | Crank Shaft Rear | MD016549 | 72*96*9 | PAYEN | NJ006 | 77 |
| MITSUBISHI | G62B 4 cyl (ohc) 1795 cc | Crank Shaft Rear | MD069947 | 72*96*9 | PAYEN | NJ251 | 9/81-5/83 |
| MITSUBISHI | FUSO GTO Z15A,16A(6G72) | Engine CRANK SHAFT FRONT | MD120700 | | MUSASHI | F4209 | 90.9~00. |
| MITSUBISHI | FUSO LEGNUM 4G93,6A12,6A13,4 G94 | Engine CRANK SHAFT FRONT | MD168055 | 37*50*6 | MUSASHI | F4184 | 96.6~02. |
| MITSUBISHI | FUSO CANTER (2T~) FG538,638 | Final Drive PINION | MH034205 | 56*99*10/34 | MUSASHI | F4232 | 93.10~99. |
| MITSUBISHI | FUSO FUSO TRUCK FS FS515 | Wheel Hub REAR INNER (F & R) | MH034175 | 130*146*14 | MUSASHI | F4175 | 96.4~00. |
| MITSUBISHI | FUSO CARISMA DA2A | FUSO CARISMA DA2A | MD755904/758763 | 41*61*9/13.5 | MUSASHI | F4221 | 01.6~ |
| MITSUBIS HI FUSO | Pajero | Transfer Input | MD711769 | 45*68.2*8.3 | | | |
| MITSUBIS HI FUSO | Rosa-BE,BH,BK | Crank Shaft Front | 31311-06101 | 48*70*12 | MUSASHI | F4084 | '79.3~'86 |
| MITSUBIS HI FUSO | Rosa-BE,BH,BK | Crank Shaft Front | ME-024156 | 55*78*12 | MUSASHI | F4022 | '79.3~'89.10 |
| MITSUBIS HI FUSO | Rosa-BE,BH,BK | Crank Shaft Front | ME-013306 | 55*78*8 | MUSASHI | | '89.10~ |
| MITSUBIS HI FUSO | Rosa-BE,BH,BK | Crank Shaft Front | ME-031051 | 72*94*12 | MUSASHI | F4016 | '81.2~ |
| MITSUBIS HI FUSO | Rosa-BE,BH,BK | Crank Shaft Front | ME-031543 | 72*94*12 | MUSASHI | F4016 | '81.2~ |
| MITSUBIS HI FUSO | Rosa-BE,BH,BK | Crank Shaft Rear | ME-011731 | 100*120*16 | MUSASHI | F4145 | '79.3~'86 |
| MITSUBIS HI FUSO | Rosa-BE,BH,BK | Crank Shaft Rear | ME-011867 | 100*124*12 | MUSASHI | | '86.1~ |
| MITSUBIS HI FUSO | Rosa-BE,BH,BK | Crank Shaft Rear | ME-031548 | 100*125*12.5 | MUSASHI | F4110 | '81.2~'86 |
| MITSUBIS HI FUSO | Rosa-BE,BH,BK | Drive Pinion | MB-005157 | 52*84*14 | MUSASHI | F4090 | '79.3~ |

| CAR | MODEL | APPLICATION | OEM NO. | SIZE | DATA acc. | CODE | YEARS |
|-----------------------|---|-----------------------------|-------------|----------------|-----------|--------|---------------|
| mitsubishi HI FUSO | Rosa-BE,BH,BK | Front Wheel | MH-034012 | 102*116*14 | MUSASHI | F4021 | '81.2~'86 |
| mitsubishi HI FUSO | Rosa-BE,BH,BK | Front Wheel | MH-034091 | 102*116*14 | MUSASHI | F4021 | '81.2~'86 |
| mitsubishi HI FUSO | Rosa-BE,BH,BK | Front Wheel | MT-327029 | 56*81*8 | MUSASHI | F4030 | '79.3~'86.1 |
| mitsubishi HI FUSO | Rosa-BE,BH,BK | Front Wheel | MT-119305 | 68*90*12 | MUSASHI | F4029 | '79.3~'86.1 |
| mitsubishi HI FUSO | Rosa-BE,BH,BK | Rear Wheel Inner | MB-161152 | 70*112*10/18 | MUSASHI | F4028 | '79.3~ |
| mitsubishi HI FUSO | Rosa-BE,BH,BK | Rear Wheel Inner | MT-100138 | 70*112*10/18 | MUSASHI | F4028 | '79.3~ |
| mitsubishi HI FUSO | Rosa-BE,BH,BK | Rear Wheel Inner | MB-161152 | 70*112*10/18.5 | MUSASHI | F4028 | '79.3~ |
| mitsubishi HI FUSO | Rosa-BE,BH,BK | Rear Wheel Inner | MT-100138 | 70*112*10/18.5 | MUSASHI | F4028 | '79.3~ |
| mitsubishi HI FUSO | Rosa-BE,BH,BK | Rear Wheel Outer | MB-308933 | 46*102*10/16 | MUSASHI | F4151 | '86.1~ |
| mitsubishi HI FUSO | Rosa-BE,BH,BK | Rear Wheel Outer | MB-161134 | 74.4*99.5*7.7 | MUSASHI | F4031 | '79.3~'86 |
| mitsubishi HI FUSO | Rosa-BE,BH,BK | Rear Wheel Outer | MT-420207 | 74.4*99.5*7.7 | MUSASHI | F4031 | '79.3~'86 |
| mitsubishi HI FUSO | Rosa-BE,BH,BK | Transmission Rear | MH-034062 | 48*65*9 | MUSASHI | F4086 | '79.3~ |
| mitsubishi HI FUSO | Rosa-BE,BH,BK | Transmission Rear | MH-034071 | 48*65*9 | MUSASHI | F4086 | '79.3~ |
| mitsubishi HI FUSO | 6D22 6 cyl Diesel 11149 cc | Crank Shaft Rear | 31212-33300 | 135*155*15 | PAYEN | NJ 980 | 84-on |
| mitsubishi HI FUSO | Canter | Engine Crank Shaft Front | | 52*74*11/19 | MUSASHI | | '93.10~ |
| mitsubishi HI FUSO | Canter | Front Wheel | MT119305 | 68*90*12 | MUSASHI | F4080 | |
| mitsubishi HI FUSO | Canter | Transmission Rear | 44114-16381 | 48*65*9 | MUSASHI | | |
| mitsubishi HI FUSO | Canter- T20#,T21#,FB,FE,F | Front Wheel | MT-227029 | 56*81*8 | MUSASHI | F4030 | '73~'89 |
| mitsubishi HI FUSO | Canter- T20#,T21#,FB,FE,F | Front Wheel | MB-025295 | 72*94*10 | MUSASHI | F4107 | '82.11~'85.10 |
| mitsubishi HI FUSO | Canter- T20#,T21#,FB,FE,F | Rear Wheel Inner | MB-116152 | 70*112*10/18 | MUSASHI | F4028 | '73~'85.12 |
| mitsubishi HI FUSO | Canter- T20#,T21#,FB,FE,F | Rear Wheel Inner | MB-116152 | 70*112*10/18.5 | MUSASHI | F4028 | '73~'85.12 |
| mitsubishi HI FUSO | Canter- T20#,T21#,FB,FE,F | Rear Wheel Inner | MB-161153 | 74*100*10 | MUSASHI | F4102 | '80.11~ |
| mitsubishi HI FUSO | Canter- T20#,T21#,FB,FE,F | Rear Wheel Inner | MB-161122 | 74*100*10 | MUSASHI | F4102 | '80.11~ |
| mitsubishi HI FUSO | Chariot Space Wagon- D02W,D03W,D05W ,D08W,D09W | Crank Shaft Rear | MD-008885 | 72*96*9 | MUSASHI | F4105 | '76~'85 |
| mitsubishi HI FUSO | Chariot Space Wagon- D02W,D03W,D05W ,D08W,D09W | Crank Shaft Rear | MD-016549 | 72*96*9 | MUSASHI | F4105 | '76~'85 |
| mitsubishi HI FUSO | Chariot Space Wagon- D02W,D03W,D05W ,D08W,D09W | Crank Shaft Rear | MD-060604 | 80*96*9 | MUSASHI | F4157 | '83.2~ |

| CAR | MODEL | APPLICATION | OEM NO. | SIZE | DATA acc. | CODE | YEARS |
|---------------------|---|------------------------------|-----------|----------------|-----------|-------|--------------|
| MITSUBIS HI FUSO | Chariot Space Wagon- D02W,D03W,D05W ,D08W,D09W | Differential Side | MD-707154 | 35*56*9/12 | MUSASHI | F4120 | '83.2~ |
| MITSUBIS HI FUSO | DELICA | Cam Shaft | MD-008672 | 35*50*8 | MUSASHI | | |
| MITSUBIS HI FUSO | DELICA | Diff Drive Pinion | MB092296 | 42*65*12 | MUSASHI | | |
| MITSUBIS HI FUSO | DELICA | Diff Drive Pinion | MB092296 | 42*65*12 | MUSASHI | | |
| MITSUBIS HI FUSO | DELICA | Rear Shaft | MB092527 | 35*58*10 | MUSASHI | | |
| MITSUBIS HI FUSO | DELICA | Timing Cover | MD008882 | 44*60*7 | MUSASHI | | |
| MITSUBIS HI FUSO | DELICA-L300--- P05W..4F A/T | Final Drive Pinion (Rear) | MB-092145 | 42*65*12 | MUSASHI | F4013 | '86.4~ |
| MITSUBIS HI FUSO | DELIGA.L300- L03#,L06#,P0#,P1#, P2#,P3# | Front Wheel | AP-2838I | 50*65*9 | MUSASHI | F4091 | '79.6~ |
| MITSUBIS HI FUSO | DELIGA.L300- L03#,L06#,P0#,P1#, P2#,P3# | Rear Wheel Inner | MB-664588 | 35*58*8.5 | MUSASHI | | '90.5~ |
| MITSUBIS HI FUSO | DELIGA.L300- L03#,L06#,P0#,P1#, P2#,P3# | Rear Wheel Inner | MB-092712 | 58*75*9 | MUSASHI | F4108 | '79.6~'82.10 |
| MITSUBIS HI FUSO | DELIGA.L300- L03#,L06#,P0#,P1#, P2#,P3# | Rear Wheel Outer | MB-001314 | 45*58*9 | MUSASHI | F4092 | '79.6~'90.5 |
| MITSUBIS HI FUSO | DELIGA.L300- L03#,L06#,P0#,P1#, P2#,P3# | Rear Wheel Outer | MB-393719 | 45*58*9 | MUSASHI | F4092 | '79.6~'90.5 |
| MITSUBIS HI FUSO | Diamante-F1#,2# | Wheel Hub Front Outer | | 57*76*6.8/9.5 | MUSASHI | F4187 | '92.10~'90.2 |
| MITSUBIS HI FUSO | Forte L200- L021P,25P,22G,26 | Cam Shaft | MD-006762 | 35*50*8 | MUSASHI | F4122 | '78~ |
| MITSUBIS HI FUSO | Forte L200- L021P,25P,22G,26 | Front Wheel | MT-141132 | 50*65*9 | MUSASHI | F4091 | '78~ |
| MITSUBIS HI FUSO | Forte L200- L021P,25P,22G,26 | Front Wheel | MB-297514 | 57*75*7.5/11 | MUSASHI | F4146 | '80.10~ |
| MITSUBIS HI FUSO | Forte L200- L021P,25P,22G,26 | Front Wheel | MB-160852 | 57*75*7.5/11 | MUSASHI | F4146 | '80.10~ |
| MITSUBIS HI FUSO | Forte L200- L021P,25P,22G,26 | Front Wheel | MB-160674 | 57*75*7.5/11 | MUSASHI | F4146 | '80.10~ |
| MITSUBIS HI FUSO | Forte L200- L021P,25P,22G,26 | Front Wheel | MB-297514 | 57*75*7.5/11.5 | MUSASHI | F4146 | '80.10~ |
| MITSUBIS HI FUSO | Forte L200- L021P,25P,22G,26 | Front Wheel | MB-160852 | 57*75*7.5/11.5 | MUSASHI | F4146 | '80.10~ |
| MITSUBIS HI FUSO | Forte L200- L021P,25P,22G,26 | Front Wheel | MB-160674 | 57*75*7.5/11.5 | MUSASHI | F4146 | '80.10~ |
| MITSUBIS HI FUSO | Forte L200- L021P,25P,22G,26 | Rear Wheel Inner | MB-092288 | 37*62*14 | MUSASHI | F4148 | '80.7~ |
| MITSUBIS HI FUSO | Forte L200- L021P,25P,22G,26 | Rear Wheel Outer | MB-092437 | 50*65*10 | MUSASHI | F4147 | '78~ |
| MITSUBIS HI FUSO | Fuso Bus | Crank Shaft Front | ME-071269 | 76*94*12 | MUSASHI | | '88.9~ |
| MITSUBIS HI FUSO | Fuso Bus Rosa- BE#,BH# | Final Drive Pinion | MB-005157 | 52*84*14 | MUSASHI | F4090 | '79.3~ |
| MITSUBIS HI FUSO | Fuso Bus- MK,MM,MP,MS,MU | Rear Dead Wheel | ME-034047 | 130*150*14 | MUSASHI | F4025 | '85~ |
| MITSUBIS HI FUSO | Fuso Bus- MK,MM,MP,MS,MU | Rear Dead Wheel | MH-034092 | 130*150*14 | MUSASHI | F4025 | '85~ |

| CAR | MODEL | APPLICATION | OEM NO. | SIZE | DATA acc. | CODE | YEARS |
|---------------------|-----------------------------------|---|-------------|-------------|-----------|-------|--------------|
| MITSUBIS HI FUSO | Fuso Bus- MK,MM,MP,MS,MU | Rear Wheel Inner | MH-034087 | 130*150*14 | MUSASHI | F4025 | '74~ |
| MITSUBIS HI FUSO | Fuso Bus- MK,MM,MP,MS,MU | Rear Wheel Inner | MH-034082 | 155*180*17 | MUSASHI | F4061 | '74~'84 |
| MITSUBIS HI FUSO | Fuso Bus- MK,MM,MP,MS,MU | Rear Wheel Inner | MH-034081 | 155*180*17 | MUSASHI | F4061 | '74~'84 |
| MITSUBIS HI FUSO | Fuso Bus- MK,MM,MP,MS,MU | Rear Wheel Inner | 03434-15600 | 155*180*17 | MUSASHI | F4061 | '74~'84 |
| MITSUBIS HI FUSO | Fuso Bus- MK,MM,MP,MS,MU | Rear Wheel Outer | MH-034006 | 65*120.5*10 | MUSASHI | F4019 | '74~'86.6 |
| MITSUBIS HI FUSO | Fuso Bus- MK,MM,MP,MS,MU | Rear Wheel Outer | MH-034078 | 65*120.5*10 | MUSASHI | F4019 | '74~'86.6 |
| MITSUBIS HI FUSO | Fuso Bus- MK,MM,MP,MS,MU | Transmission Front | ME-622400 | 34*50*7 | MUSASHI | F4017 | '74~'79 |
| MITSUBIS HI FUSO | Fuso Bus- MK,MM,MP,MS,MU | Transmission Front | ME-620713 | 34*50*7 | MUSASHI | F4017 | '74~'79 |
| MITSUBIS HI FUSO | Fuso Bus- MK,MM,MP,MS,MU | Transmission Front | ME-624211 | 40*58*8 | MUSASHI | F4132 | '80~'83 |
| MITSUBIS HI FUSO | Fuso Bus- MK,MM,MP,MS,MU | Transmission Front | ME-623281 | 40*58*8 | MUSASHI | F4132 | '80~'83 |
| MITSUBIS HI FUSO | Fuso Bus- MK,MM,MP,MS,MU | Transmission Front | 44514-51681 | 45*60*9 | MUSASHI | F4089 | '77~'79 |
| MITSUBIS HI FUSO | Fuso Bus- MK,MM,MP,MS,MU | Transmission Front | 44514-51600 | 45*60*9 | MUSASHI | F4089 | '77~'79 |
| MITSUBIS HI FUSO | Fuso Bus- MK,MM,MP,MS,MU | Transmission Front | 44514-16181 | 52*65*9 | MUSASHI | F4117 | '76~'89.3 |
| MITSUBIS HI FUSO | Fuso Bus- MK,MM,MP,MS,MU | Transmission Front | 44514-46181 | 52*65*9 | MUSASHI | F4117 | '80~'90.2 |
| MITSUBIS HI FUSO | Fuso Bus- MK,MM,MP,MS,MU | Transmission Front | 44514-48100 | 52*65*9 | MUSASHI | F4117 | '76~'89.3 |
| MITSUBIS HI FUSO | Fuso Bus- MK,MM,MP,MS,MU | Transmission Front | 44514-46100 | 52*65*9 | MUSASHI | F4117 | '80~'90.2 |
| MITSUBIS HI FUSO | Fuso Bus- MK,MM,MP,MS,MU | Transmission Rear | MH-034036 | 55*72*9 | MUSASHI | F4024 | '74~'79 |
| MITSUBIS HI FUSO | Fuso Bus- MK,MM,MP,MS,MU | Transmission Rear | MF-502488 | 58*75*9 | MUSASHI | F4137 | '80~ |
| MITSUBIS HI FUSO | Fuso Bus- MK,MM,MP,MS,MU | Transmission Rear | ME-624694 | 58*75*9 | MUSASHI | F4137 | '80~ |
| MITSUBIS HI FUSO | Fuso Bus- MK,MM,MP,MS,MU | Transmission Rear | MH-034153 | 70*92*12 | MUSASHI | F4174 | '90.3~'90.4 |
| MITSUBIS HI FUSO | Fuso Bus- MK,MM,MP,MS,MU | Transmission Rear | 44414-58181 | 70*92*12 | MUSASHI | F4088 | '76~'90.2 |
| MITSUBIS HI FUSO | Fuso Bus- MK,MM,MP,MS,MU | Transmission Rear | 44414-58100 | 70*92*12 | MUSASHI | F4088 | '76~'90.2 |
| MITSUBIS HI FUSO | Fuso Bus- MK,MM,MP,MS,MU | Transmission Rear | MH-034060 | 75*100*13 | MUSASHI | F4116 | '88.6~'90.2 |
| MITSUBIS HI FUSO | Fuso Tractor-6D2# | Engine Crank Shaft Front | ME-061853 | 95*120*13 | MUSASHI | F4127 | |
| MITSUBIS HI FUSO | Fuso Tractor- FP419...M130 T/M | Transmission Rear | | 80*105*13 | MUSASHI | F4199 | '90.10~'91.8 |
| MITSUBIS HI FUSO | Fuso Tractor-FV | Transmission Rear | 44514-46661 | 80*105*13 | MUSASHI | F4138 | '76~'79 |
| MITSUBIS HI FUSO | Fuso Tractor-FV | Transmission Rear | MH-034102 | 85*110*13 | MUSASHI | F4217 | '85.9~'88.8 |
| MITSUBIS HI FUSO | Fuso Truck 10t~12t- FT | Rear Wheel Inner | MH-034061 | 155*180*17 | MUSASHI | F4061 | '74~'83 |
| MITSUBIS HI FUSO | Fuso Truck 10t~12t- FT | Transmission Front | 44514-51661 | 45*60*9 | MUSASHI | F4089 | '74~'79 |
| MITSUBIS HI FUSO | Fuso Truck 10t~12t- FV | Rear Wheel Inner (Forward & Rearward) | 03431-15600 | 155*180*17 | MUSASHI | F4061 | '74~'83 |

| CAR | MODEL | APPLICATION | OEM NO. | SIZE | DATA acc. | CODE | YEARS |
|---------------------|--|-----------------------------|-------------|-----------------|-----------|--------|---------------|
| MITSUBIS HI FUSO | Fuso Truck 10t~12t- FV | Transmission Rear | MH-034138 | 70*92*12 | MUSASHI | F4174 | '89.3~'89.11 |
| MITSUBIS HI FUSO | Fuso Truck(3.5t~5.5t)- | Crank Shaft Front | MH-034027 | 55*78*12 | MUSASHI | F4022 | '78.11~'89.10 |
| MITSUBIS HI FUSO | Fuso Truck(3.5t~5.5t)- | Front Wheel | MH-034085 | 102*116*14 | MUSASHI | F4021 | '76~ |
| MITSUBIS HI FUSO | Fuso Truck(3.5t~5.5t)- | Proceller Shaft | MH-034066 | 60*85*12 | MUSASHI | | '79.9~ |
| MITSUBIS HI FUSO | Fuso Truck(6t~7t)- FM | Crank Shaft Rear | ME-034976 | 108*180*17.5 | PAYEN | NJ 910 | |
| MITSUBIS HI FUSO | Fuso Truck(6t~7t)- FM | Drive Pinion | 12020-29600 | 70*122*12/30 | MUSASHI | F4133 | '76.10~ |
| MITSUBIS HI FUSO | Fuso Truck(6t~7t)- FM | Drive Pinion | MH-034143 | 70*122*12/30 | MUSASHI | F4133 | '76.10~ |
| MITSUBIS HI FUSO | Fuso Truck.Tractor(7.5t~1 0t)-FP | Front Wheel | MH-034089 | 134*152*11 | MUSASHI | F4166 | '85.9~ |
| MITSUBIS HI FUSO | Fuso Truck-FM5# | Wheel Hub Rear Inner | MC807438 | 154*172*14 | MUSASHI | F4134 | '84.2~ |
| MITSUBIS HI FUSO | Fuso Truck- FU113...J,JD | Transmission Rear | 44514-46601 | 80*105*13 | MUSASHI | F4138 | '76~'79 |
| MITSUBIS HI FUSO | Galant(F.W.D.)- E1#E3# | Balancer Shaft | MD-151463 | 28*40*8 | MUSASHI | F4124 | '83.8~'87.8 |
| MITSUBIS HI FUSO | Galant(F.W.D.)- E1#E3# | Crank Shaft Front | MD-168061 | 44*60*7 | MUSASHI | F4104 | '83.8~ |
| MITSUBIS HI FUSO | Galant(F.W.D.)- E1#E3# | Differential Side | MD-707184 | 35*56*9/12 | MUSASHI | F4120 | '83.8~ |
| MITSUBIS HI FUSO | Galant(F.W.D.)- E1#E3# | Differential Side | MD-706433 | 35*56*9/12 | MUSASHI | F4120 | '83.8~ |
| MITSUBIS HI FUSO | Galant(F.W.D.)- E1#E3# | Front Wheel (Inner) | MB-303867 | 50*82*8/11 | MUSASHI | F4158 | '84.10~'84.5 |
| MITSUBIS HI FUSO | Galant(F.W.D.)- E1#E3# | Front Wheel (Inner) | MB-573309 | 54*82*8/11 | MUSASHI | F4172 | '87.8~ |
| MITSUBIS HI FUSO | Galant(F.W.D.)- E1#E3# | Front Wheel (Inner) | MB-808443 | 54*82*8/11 | MUSASHI | F4172 | '87.8~ |
| MITSUBIS HI FUSO | Galant(F.W.D.)- E1#E3# | Front Wheel (Outer) | MB-109057 | 50*66.5*13/15.5 | MUSASHI | F4094 | '83.8~'87.8 |
| MITSUBIS HI FUSO | Galant(F.W.D.)- E1#E3# | Front Wheel (Outer) | MB-176746 | 50*66.5*13/15.5 | MUSASHI | F4094 | '83.8~'87.8 |
| MITSUBIS HI FUSO | Galant(F.W.D.)- E1#E3# | Front Wheel (Outer) | MB-633944 | 50*66.5*13/15.5 | MUSASHI | F4094 | '83.8~'87.8 |
| MITSUBIS HI FUSO | Galant(F.W.D.)- E1#E3# | Front Wheel (Outer) | MB-303866 | 50*72*8/11 | MUSASHI | | '84.5~'84.7 |
| MITSUBIS HI FUSO | Galant(F.W.D.)- E1#E3# | Front Wheel (Outer) | MB-303875 | 52*72*8/11 | MUSASHI | F4159 | '84.10~'87.8 |
| MITSUBIS HI FUSO | Galant(F.W.D.)- E1#E3# | Front Wheel (Outer) | MB-808444 | 52*72*8/11 | MUSASHI | F4159 | '84.10~'87.8 |
| MITSUBIS HI FUSO | Galant(F.W.D.)- E1#E3# | Rear Wheel | MB-584745 | 45*62*6 | MUSASHI | F4012 | '86.10~'86.10 |
| MITSUBIS HI FUSO | Galant(F.W.D.)- E1#E3# | Rear Wheel | MB-002074 | 45*62*6 | MUSASHI | F4012 | '86.10~'86.10 |
| MITSUBIS HI FUSO | Galant(F.W.D.)- E1#E3# | Transmission Input Shaft | MD-050608 | 25*35*6 | MUSASHI | F4162 | '85.9~ |
| MITSUBIS HI FUSO | Galant(F.W.D.)- E1#E3# | Transmission Input Shaft | MD-701735 | 25*35*6 | MUSASHI | F4015 | '83.8~'85.8 |
| MITSUBIS HI FUSO | Galant(FWD) | Engine Crank Shaft Rear | | 85*103*8 | MUSASHI | F4206 | '92.3~ |
| MITSUBIS HI FUSO | Galant(R.W.D.)- A12#13#16# | Rear Wheel | MT-141546 | 42*55*9 | MUSASHI | F4009 | '77.6~'80 |
| MITSUBIS HI FUSO | Galant(R.W.D.)- A12#13#16# | Rear Wheel | MA-125991 | 51*65*9 | MUSASHI | F4010 | '76.6~'86 |

| CAR | MODEL | APPLICATION | OEM NO. | SIZE | DATA acc. | CODE | YEARS |
|---------------------|---|--|-----------|---------------|-----------|-------|--------------|
| MITSUBIS HI FUSO | Galant(R.W.D.)- A12#13#16# | Rear Wheel | MA-181498 | 51*65*9 | MUSASHI | F4010 | '76.6~'86 |
| MITSUBIS HI FUSO | Galant,ETERNA | Crank Shaft Front | MD-000254 | 44*65*11 | MUSASHI | F4113 | '69~'76 |
| MITSUBIS HI FUSO | Galant,ETERNA | Diff Drive Pinion | MB160578 | 42*65*12 | MUSASHI | | |
| MITSUBIS HI FUSO | Galant,ETERNA | Diff Drive Pinion | MB160578 | 42*65*12 | MUSASHI | | |
| MITSUBIS HI FUSO | Galant,ETERNA | Diff Drive Pinion | MB092145 | 42*65*12 | MUSASHI | | |
| MITSUBIS HI FUSO | Galant,ETERNA | Timing Cover | MD020308 | 48*68*11 | MUSASHI | | |
| MITSUBIS HI FUSO | Lancer(R.W.D.)- A14#,A17# | Crank Shaft Front | MD-030782 | 30*46*8 | MUSASHI | F4143 | '77~'87 |
| MITSUBIS HI FUSO | Lancer(RWD)- A175A | Transmission Front | | 36*52*10 | MUSASHI | F4097 | '81.11~'87 |
| MITSUBIS HI FUSO | Mini Cab- L01#,U1#,4# | Engine Cam Shaft | MD-162689 | 35*47*8 | MUSASHI | F6310 | '90.9~'91 |
| MITSUBIS HI FUSO | Mini Cab- L013,15,U11,12,14, 15,18,19 | Drive Pinion | MB-393929 | 35*65*12 | MUSASHI | F4011 | '84.6~'90.1 |
| MITSUBIS HI FUSO | Mini Cab- L013,15,U11,12,14, 15,18,19 | Front Wheel | MT-131243 | 42*53*8 | MUSASHI | F6304 | '79.10~'84.6 |
| MITSUBIS HI FUSO | Mini Cab- L013,15,U11,12,14, 15,18,19 | Transmission Rear | MV-037781 | 28*45*10 | MUSASHI | F6302 | '79.10~'84.6 |
| MITSUBIS HI FUSO | Mirage,Lancer(FWD) | Engine Crank Shaft Front | | 37*50*6 | MUSASHI | F4184 | '91.8~'91.12 |
| MITSUBIS HI FUSO | Mirage,Lancer(FWD)- 4G13,4G15...CA1,2, | Engine Crank Shaft Front | | 30*46*7 | MUSASHI | F4123 | '91.8~ |
| MITSUBIS HI FUSO | Mirage,Lancer(FWD)-A15# | Transmission & Differential Mission Case | | 35*56*9/12 | MUSASHI | F4120 | '78.3~'85 |
| MITSUBIS HI FUSO | Mirage,Lancer(FWD)-A15#,C# | Wheel Hub Front Inner | MB-808443 | 54*76*8/11 | MUSASHI | F4178 | '91.8~ |
| MITSUBIS HI FUSO | Mirage,Lancer(FWD)-A15#,C# | Wheel Hub Front Outer | MB808444 | 51.9*66*8/10 | MUSASHI | F4179 | '91.8~ |
| MITSUBIS HI FUSO | Mirage,Lancer- A15#,C1#,3#,5#,6#, 6#,8# | Crank Shaft Front | MD-153104 | 30*45*6 | MUSASHI | | '89.10~ |
| MITSUBIS HI FUSO | Mirage,Lancer- A15#,C1#,3#,5#,6#, 6#,8# | Crank Shaft Front | MD-031837 | 30*46*8 | MUSASHI | F4143 | '78.2~'89.9 |
| MITSUBIS HI FUSO | Mirage,Lancer- A15#,C1#,3#,5#,6#, 6#,8# | Rear Wheel | MB-242822 | 39*52*6/11.5 | MUSASHI | F4160 | '83.10~'87.9 |
| MITSUBIS HI FUSO | Mirage,Lancer- A15#,C1#,3#,5#,6#, 6#,8# | Rear Wheel | MB-584601 | 39*52*6/11.5 | MUSASHI | F4160 | '83.10~'87.9 |
| MITSUBIS HI FUSO | Mirage,Lancer- A15#,C1#,3#,5#,6#, 6#,8# | Rear Wheel | MB-242821 | 39*52*6/11.5 | MUSASHI | F4160 | '83.10~'87.9 |
| MITSUBIS HI FUSO | Pajero-ALL | Drive Pinion Rear | MB-160949 | 45*72*12/20.5 | MUSASHI | F4163 | '82.4~ |
| MITSUBIS HI FUSO | Pajero-L04#,L14# | Crank Shaft Rear | MD-101915 | 91*111*9 | MUSASHI | | '88.9~ |
| MITSUBIS HI FUSO | Pajero-L04#,L14# | Drive Pinion (Front) | MB-160578 | 42*65*12 | MUSASHI | F4136 | '82.4~ |

| CAR | MODEL | APPLICATION | OEM NO. | SIZE | DATA acc. | CODE | YEARS |
|------------------|----------------------------------|----------------------------------|-------------|----------------|-----------|-------|--------------|
| MITSUBIS HI FUSO | Pajero-L04#,L14# | Drive Pinion (Rear) | MB-160949 | 45*72*12/20.5 | MUSASHI | F4163 | '82.4~ |
| MITSUBIS HI FUSO | Pajero-L04#,L14# | Front Wheel | MB-526395 | 57*75*7.5/11 | MUSASHI | F4146 | '82.4~ |
| MITSUBIS HI FUSO | Pajero-L04#,L14# | Front Wheel | MB-290739 | 57*75*7.5/11 | MUSASHI | F4146 | '82.4~ |
| MITSUBIS HI FUSO | Pajero-L04#,L14# | Front Wheel | MB-160352 | 57*75*7.5/11 | MUSASHI | F4146 | '82.4~ |
| MITSUBIS HI FUSO | Pajero-L04#,L14# | Front Wheel | MB-526395 | 57*75*7.5/11.5 | MUSASHI | F4146 | '82.4~ |
| MITSUBIS HI FUSO | Pajero-L04#,L14# | Front Wheel | MB-290739 | 57*75*7.5/11.5 | MUSASHI | F4146 | '82.4~ |
| MITSUBIS HI FUSO | Pajero-L04#,L14# | Front Wheel | MB-160352 | 57*75*7.5/11.5 | MUSASHI | F4146 | '82.4~ |
| MITSUBIS HI FUSO | Pajero-L04#,L14# | Rear Wheel Inner | MB-837719 | 37*62*14 | MUSASHI | F4148 | '82.4~'89.12 |
| MITSUBIS HI FUSO | Pajero-L04#,L14# | Transmission Input Shaft | MH-034067 | 32*45*8 | MUSASHI | F4129 | '89.5 |
| MITSUBIS HI FUSO | President | Transmission Rear | 31336-X0101 | 35*50*11 | MUSASHI | | |
| MITSUBIS HI FUSO | RVR-N1#,2# | Transfer & Rear Diff Drive Shaft | | 30*45*7 | MUSASHI | | '91.1~ |
| MITSUBIS HI FUSO | RVR-N23W,28W...GS# | Wheel Hub Front Inner | | 60*86*7/12.5 | MUSASHI | F4186 | '92.9~ |
| MITSUBIS HI FUSO | Starion-A182,183,184,187 | Balancer Shaft | MD-069950 | 25*35*6 | MUSASHI | F4162 | '82.4~'88 |
| MITSUBIS HI FUSO | Starion-A182,183,184,187 | Cam Shaft | MD-133317 | 35*50*8 | MUSASHI | F4122 | '82.4~'85 |
| MITSUBIS HI FUSO | Starion-A182,183,184,187 | Crank Shaft Front | MD-069949 | 44*60*7 | MUSASHI | F4104 | '76~'86 |
| MITSUBIS HI FUSO | Starion-A182,183,184,187 | Drive Pinion | MB-092145 | 42*65*12 | MUSASHI | F4013 | '82.4~'88 |
| MITSUBIS HI FUSO | Starion-A182,183,184,187 | Oil Pump | MD-050605 | 17*28*7 | MUSASHI | F4123 | '76.6~'86 |
| MITSUBIS HI FUSO | Starion-A182,183,184,187 | Oil Pump | MD-069948 | 17*28*7 | MUSASHI | F4123 | '76.6~'86 |
| MITSUBIS HI FUSO | Starion-A182,183,184,187 | Transmission Front | MD-703735 | 30*45*6 | MUSASHI | F4096 | '82.4~ |
| MITSUBIS HI FUSO | Starion-A182,183,184,187 | Transmission Front | MD-723202 | 30*45*6 | MUSASHI | F4096 | '82.4~ |
| MITSUBIS HI FUSO | Starion-A182,183,184,187 | Transmission Rear | AH-1895E | 32*48*10 | MUSASHI | F4014 | '82.4~'83.3 |
| MITSUBIS HI FUSO | Starion-A182,183,184,187 | Transmission Rear | MD-701430 | 32*48*10 | MUSASHI | F4014 | '82.4~'83.3 |
| MITSUBIS HI FUSO | Starion-A182,183,184,187 | Transmission Rear | MD-703743 | 36*52*10 | MUSASHI | F4097 | '82.4~ |
| MITSUBIS HI FUSO | Tractor | Timing Cover | 31507-06300 | 95*120*13 | MUSASHI | | |
| MITSUBIS HI FUSO | Tredia.Cordia -A21# | Engine Crank Shaft Rear | MD-117643 | 72*96*9 | MUSASHI | F4105 | '83.8~'87.8 |
| MITSUBIS HI FUSO | TrediaA.Cordia -A211,212,213,215 | Crank Shaft Front | MD-050606 | 44*60*7 | MUSASHI | F4104 | '76~'86 |
| MITSUBIS HI FUSO | TrediaA.Cordia -A211,212,213,215 | Crank Shaft Front | MD-008882 | 44*60*7 | MUSASHI | F4104 | '76~'86 |
| MITSUBIS HI FUSO | Truck | Front Wheel | 03434-08900 | 102*116*14 | MUSASHI | | |
| MITSUBIS HI FUSO | Truck | Rear Wheel Inner | 03434-14500 | 145*175*14 | MUSASHI | | |
| MITSUBIS HI FUSO | Truck | Transmission Front | 44154-46100 | 52*65*9 | MUSASHI | | |

| CAR | MODEL | APPLICATION | OEM NO. | SIZE | DATA acc. | CODE | YEARS |
|---------------------|-----------|-----------------------|-------------|-----------------|-----------|-------|---------------|
| MITSUBIS HI FUSO | Truck | Transmission Rear | 44214-03400 | 55*72*9 | MUSASHI | | |
| MITSUBIS HI FUSO | Truck.Bus | Front Wheel | 03434-13500 | 135*165*14 | MUSASHI | | |
| MITSUBIS HI FUSO | Truck.Bus | Propeller Shaft | MH-034065 | 70*100*13 | MUSASHI | | '78.6~'89.11 |
| MITSUBIS HI FUSO | Truck.Bus | Rear Wheel Inner | 03434-13000 | 130*150*14 | MUSASHI | | |
| MITSUBIS HI FUSO | Truck.Bus | Rear Wheel Inner | 03434-15601 | 155*180*17 | MUSASHI | | |
| MITSUBIS HI FUSO | Truck.Bus | Rear Wheel Inner | 03434-15602 | 155*180*17 | MUSASHI | | |
| MITSUBIS HI FUSO | Truck.Bus | Rear Wheel Inner | 03434-15520 | 155*190*17 | MUSASHI | | |
| MITSUBIS HI FUSO | Truck.Bus | Rear Wheel Outer | 3431-06001 | 60*72*12 | MUSASHI | F4044 | |
| MITSUBIS HI FUSO | Truck.Bus | Timing Cover | 31507-06500 | 95*120*13 | MUSASHI | | |
| MITSUBIS HI FUSO | | Balancer Shaft | MD-008883 | 28*40*8 | MUSASHI | F4124 | '76.6~'86 |
| MITSUBIS HI FUSO | | Balancer Shaft RH | MD-50608 | 25*35*6 | MUSASHI | F4162 | '79.6~ |
| MITSUBIS HI FUSO | | Cam Shaft | MD-153103 | 35*50*8 | MUSASHI | F4122 | '76.6~'86 |
| MITSUBIS HI FUSO | | Cam Shaft | MD-016310 | 35*50*8 | MUSASHI | F4122 | '76.6~'86 |
| MITSUBIS HI FUSO | | Crank Shaft Front | ME-001509 | 48*70*8 | MUSASHI | | '89.11~ |
| MITSUBIS HI FUSO | | Crank Shaft Front | ME-013305 | 55*78*8 | MUSASHI | | '89.11~ |
| MITSUBIS HI FUSO | | Crank Shaft Rear | ME-011667 | 100*124*12 | MUSASHI | | '88.10~ |
| MITSUBIS HI FUSO | | Crank Shaft Rear | ME-023152 | 100*125*12.5 | MUSASHI | F4110 | '76~'84 |
| MITSUBIS HI FUSO | | Crank Shaft Rear | ME-031584 | 105*125*11 | MUSASHI | F4115 | '74~'84 |
| MITSUBIS HI FUSO | | Crank Shaft Rear | ME-023491 | 105*125*11 | MUSASHI | F4115 | '76~'89 |
| MITSUBIS HI FUSO | | Crank Shaft Rear | ME-001195 | 90*113*15 | MUSASHI | | '78.11~'86.9 |
| MITSUBIS HI FUSO | | Drive Pinion | MB-001170 | 35*65*12 | MUSASHI | F4011 | '76.6~'83 |
| MITSUBIS HI FUSO | | Drive Pinion | MB-092296 | 42*65*12 | MUSASHI | F4013 | '77.11~'86 |
| MITSUBIS HI FUSO | | Drive Pinion | MH-034213 | 52*84*14 | MUSASHI | F4090 | '76.11~'85.10 |
| MITSUBIS HI FUSO | | Drive Pinion | 12020-59600 | 70*142*12/36 | MUSASHI | F4106 | '85~'90.2 |
| MITSUBIS HI FUSO | | Rear Wheel Outer | MB-308934 | 46*95*10/14 | MUSASHI | F4152 | '85.10~ |
| MITSUBIS HI FUSO | | Transmission Front | MH-034057 | 32*45*8 | MUSASHI | F4129 | '80.11~'79.4 |
| MITSUBIS HI FUSO | | Transmission Front | 44614-46181 | 52*65*9 | MUSASHI | F4117 | '83.9~'90.2 |
| MITSUBIS HI FUSO | | Transmission Rear | MH-034157 | 80*105*13 | MUSASHI | | '90.10~ |
| MITSUBIS HI FUSO | | Transmission Rear | MH-034120 | 80*105*13 | MUSASHI | | '89.3~ |
| MITSUBIS HI FUSO | | | ME-060124 | 100*125*13.8/21 | | | '85.9~'89.3 |

| CAR | MODEL | APPLICATION | OEM NO. | SIZE | DATA acc. | CODE | YEARS |
|---------------------|---|---|-----------------|----------------|-----------|--------|--------------|
| MITSUBIS HI FUSO | | | MB-166582 | 19*35*7 | PAYEN | NJ986 | |
| MITSUBIS HI FUSO | BE434.435.437 | Transmission Feont | MB622400 | 34*50*7 | PAYEN | NJ396 | 1/86-on |
| MITSUBIS HI FUSO | Minica- A10#,H1#,H2# | Crank Shaft Rear | MD-112895 | 60*75*8 | MUSASHI | | '88.11~ |
| MITSUBIS HI FUSO | Mini Cab- L013,15,U11,12,14, 15,18,19 | Crank Shaft Rear | MD-112695 | 60*75*8 | MUSASHI | | '87.6~ |
| MITSUBIS HI FUSO | Fuso Tractor-FP414 | Wheel Hub Rear Inner | MH-034084 | 160*182*17 | MUSASHI | F4167 | '90.10~'89.3 |
| MITSUBIS HI FUSO | DELICA-L300---P01V....STD Roof | Rear Wheel Inner | MA-181498 | 51*65*9 | MUSASHI | F4010 | '86.4~'90.7 |
| MITSUBIS HI FUSO | Mini Cab-L013,15,U11,12,14,15,18,19 | Front Wheel | MT-131243 | 42*53*8 | MUSASHI | F6304 | '79.10~'84.6 |
| MITSUBISHI FUSO | Mini Cab- L013,15,U11,12,14, 15,18,19 | Transmission Rear | MV-037781 | 28*45*10 | MUSASHI | F6302 | '79.10~'84.6 |
| MITSUBISHI FUSO | FUSO CHARIOT / SPACE WAGON N43W,44W,48W | Mission & Differential (MT&AT) FRONT DIFF. CASE (LH) | MD719710 | 35*54*10/17 | MUSASHI | F4203 | 91.3~97. |
| MAZDA | 323 BD BD1031.BD1051 | Front wheel inner | B001-33-065/A | 52*68*7/13 | PAYEN | NJ 537 | |
| MAZDA | 323 BD BD1031.BD1051 | Front wheel outer | B001-33-067 | 51*63*6 | PAYEN | NJ 428 | |
| MAZDA | 323 BW | Differential | F001/01-27-238 | 35*56*9/15 | PAYEN | NJ 452 | |
| MAZDA | 323 BW | Rear wheel outer | B210-33-067 | 51*63*8.5/12 | PAYEN | NJ 129 | |
| MAZDA | 323 BW BW3.BW5.BW7.BW M...2WD | Front wheel outer | B092-33-067 | 51*63*8.5 | PAYEN | NJ 808 | |
| MAZDA | 323 PN 4 CYL (OHC) 1720 cc | Cam Shaft | B630-10-602/A | 30*44*7 | PAYEN | NJ 448 | |
| MAZDA | 323 TB 4 CYL (OHV) 1169 cc | Timing Cover | 0187-10-507A/B | 40*55*8 | PAYEN | NB 384 | |
| MAZDA | 929 JE V6 CYL (OHC) 2954 cc | | JF01-11-312 | 75*93*9 | PAYEN | NK 035 | |
| MAZDA | ALL | Differential | F001-27-238 | 35*56*9/15 | PAYEN | NJ452 | 9/82-3/87 |
| MAZDA | ALL | Rear Wheel | 0187-26-154 | 42*55*9 | PAYEN | NJ052 | 9/78-86 |
| MAZDA | ALL | Transmission | 0437-17-335A | 35*48/55*13/15 | PAYEN | NJ263 | |
| MAZDA | B SERIES AM 4 CYL (OHC) 2555 cc | Timing Cover | JE15-10-602 | 46*60*7 | PAYEN | NJ 978 | |
| MAZDA | B SERIES PE ALL | Front wheel | 3900-33-065 | 45*65*5 | PAYEN | NJ 574 | |
| MAZDA | B SERIES PE ALL | Propeller Shaft | 0290-26-151 | 32*52*7 | PAYEN | NJ 946 | |
| MAZDA | B SERIES PE ALL | | 0603-33-065 | 45*65*5 | PAYEN | NJ 041 | |
| MAZDA | B SERIES R2 4 CYL Diesel 2184 cc | Crank Shaft Rear | F81/02-11-399 | 90*110*9 | PAYEN | NJ 325 | |
| MAZDA | B SERIES VB 4 CYL (OHC) 1796 cc | Timing Cover | 0221-10-602/A/B | 48*70*12 | PAYEN | NJ 042 | |
| MAZDA | B2 | Crank Shaft Front | BH5434E | 60*76*7 | TONYCO | | |
| MAZDA | BD1031,BD1051 | Front Wheel | E7GZ-1177A | 52*68*7/13 | PAYEN | NJ537 | 5/80-12/84 |
| MAZDA | BD1031,BD1051 | Transmission | 0613-16-103 | 24*40*8 | PAYEN | NJ084 | 5/80-12/84 |
| MAZDA | BF3,BF5,BFM,BFS, BFT 2WD | Front Wheel (Outer) | E7GZ-1177B | 51*63*8.5 | PAYEN | NJ808 | 1/85-on |
| MAZDA | BONGO BRAUNY- SD...S Tire (Long Body) | Differential Pinion | W001-27-165 | 50*75*12/17 | MUSASHI | M4544 | '83.6~ |
| MAZDA | BONGO BRAUNY- SR,SD...W Tire (2WD) | Wheel Hub Rear Inner | | 65*90*13 | MUSASHI | M4626 | '88.1~ |

| CAR | MODEL | APPLICATION | OEM NO. | SIZE | DATA acc. | CODE | YEARS |
|-------|---|---|------------------|---------------|-----------|--------|--------------|
| MAZDA | BONGO.E2000-BA,SS,SE,SR,SD | Front Wheel | S113-33-067 | 52*70*9 | MUSASHI | M4561 | '83.6~ |
| MAZDA | BONGO.E2000-BA,SS,SE,SR,SD | Front Wheel | 9958-55-2709 | 52*70*9 | MUSASHI | M4561 | '83.6~ |
| MAZDA | BONGO.E2000-BA,SS,SE,SR,SD | Rear Shaft Inner | 0603-26-154 | 35*55*8 | MUSASHI | M4549 | '85.9~'87.9 |
| MAZDA | BONGO.E2000-BA,SS,SE,SR,SD | Rear Shaft Inner | UB40-26-154 | 35*58*10 | MUSASHI | M4628 | '90.3~ |
| MAZDA | BONGO.E2000-BA,SS,SE,SR,SD | Rear Shaft Inner | 1011-26-154 | 47*62*9 | MUSASHI | M4519 | '83.9~ |
| MAZDA | BONGO.E2000-BA,SS,SE,SR,SD | Rear Shaft Inner | 9958-55-5729 | 55*72*9 | MUSASHI | M4565 | '83.6~'85.8 |
| MAZDA | BONGO.E2000-BA,SS,SE,SR,SD | Rear Shaft Inner | 9958-55-5782 | 55*78*12 | MUSASHI | M4526 | '77.8~'85.1 |
| MAZDA | BONGO.E2000-BA,SS,SE,SR,SD | Rear Shaft Inner | 0804-26-154 | 58*80*9 | MUSASHI | M4516 | '83.6~ |
| MAZDA | BONGO.E2000-BA,SS,SE,SR,SD | Rear Shaft Inner | W001-33-065 | 65*90*13 | MUSASHI | M4532 | '83.6~'88.1 |
| MAZDA | BONGO.E2000-BA,SS,SE,SR,SD | Rear Shaft Inner | S483-28-154 | 65*90*13 | MUSASHI | M4626 | '88.1~'87.9 |
| MAZDA | BONGO.E2000-BA,SS,SE,SR,SD | Rear Shaft Inner | 9958-56-5903 | 65*90*13 | MUSASHI | M4532 | '83.6~'88.1 |
| MAZDA | BONGO.E2000-BA,SS,SE,SR,SD | Rear Wheel Outer | 1416-26-157 | 38*45*8 | MUSASHI | M4537 | '83.6~ |
| MAZDA | BONGO.E2000-BA,SS,SE,SR,SD | Rear Wheel Outer | 0604-26-184 | 42*65*9 | MUSASHI | M4552 | '83.6~ |
| MAZDA | BONGO.E2000-BA,SS,SE,SR,SD | Rear Wheel Outer | 0603-26-157 | 48*70*9 | MUSASHI | M4550 | '83.6~'87.9 |
| MAZDA | Capella 626(F.W.D.)- | Crank Shaft Rear | B630-11-312 | 83*100*9 | MUSASHI | | '87.3~ |
| MAZDA | Capella 626(F.W.D.)- | Front Drive Shaft Inner | G001-25-744A | 38*62*7/8 | MUSASHI | M4562 | '82.9~'87.3 |
| MAZDA | Capella 626(F.W.D.)- | Rear Axle | GJ21-26-154 | 42*58*7 | MUSASHI | M4616 | '87.3~ |
| MAZDA | Capella 626(F.W.D.)- | Timing Cover | F801-10-802 | 34*48*7 | MUSASHI | M4570 | '82.9~'87.3 |
| MAZDA | Capella GC ALL | Rear wheel | G030-26-154/A | 39*50.5*8.5 | PAYEN | NJ 631 | |
| MAZDA | Capella GD GD...drum brake | Rear wheel | GJ21-26-154 | 42*58*7 | PAYEN | NJ 811 | |
| MAZDA | Capella TELSTAR.626...Sedan-GC,GD,GE,CG | Engine Oil Pump | E43E-6700D | 34*48*7 | MUSASHI | M4570 | '82.9~'94 |
| MAZDA | Capella TELSTAR.626...Sedan-GC,GD,GE,CG | Timing Cover | RF01-12-602 | 30*44*7 | MUSASHI | M4619 | '83.9~'83.6 |
| MAZDA | Capella TELSTAR.626...Sedan-GC,GD,GE,CG | Transmission & Differential Front Diff Side | F001/03-27-238 | 35*56*9/15 | MUSASHI | M4542 | '82.9~ |
| MAZDA | Capella TELSTAR.626...Sedan-GC,GD,GE,CG | Wheel Hub Front | G304/GJ21-33-065 | 56*68/74*5/10 | MUSASHI | M4615 | '87.3~ |
| MAZDA | CD2VC | Front Wheel | 9958-54-8629 | 48*62*9 | PAYEN | NJ562 | 10/75-7/79 |
| MAZDA | CD3MC | Front Wheel | 0398-33-065 | 40*54*6 | PAYEN | NJ089 | 1/78-81 |
| MAZDA | COSMO CD CD2VC | Front wheel | 9958-54-8629 | 48*62*9 | PAYEN | NJ 562 | |
| MAZDA | COSMO HB ALL | Front wheel | H001-33-065/A | 52*63*8 | PAYEN | NJ 920 | |
| MAZDA | COSMO-CD,HB | Crank Shaft Rear | FB01-11-399 | 90*110*9 | MUSASHI | M4571 | '83.9~'90 |
| MAZDA | COSMO-CD,HB | Crank Shaft Rear | FB02-11-399 | 90*110*9 | MUSASHI | M4571 | '83.9~'90 |
| MAZDA | COSMO-CD,HB | Differential Pinion | 0223-27-018 | 40*64*12 | MUSASHI | M4506 | '75.10~'81 |
| MAZDA | COSMO-CD,HB | Front Wheel | 9958-54-8629 | 48*62*9 | MUSASHI | M4525 | '75.10~'79 |
| MAZDA | COSMO-CD,HB...Gasoline | Engine Timing Gear Cover | | 48*70*12 | MUSASHI | M4504 | '75.10~'83.8 |

| CAR | MODEL | APPLICATION | OEM NO. | SIZE | DATA acc. | CODE | YEARS |
|-------|---|-------------------------|------------------|---------------|-----------|--------|--------------|
| MAZDA | Domingo.BP | Engine Crank Shaft Rear | | 83*100*9 | MUSASHI | M4648 | '93.8~ |
| MAZDA | Domingo.NA6CE,N A8C | Differential Pinion | M054-27-165 | 40*64*11/16 | MUSASHI | M4633 | '93.8~ |
| MAZDA | Domingo.NA6CE,N A8C | Engine Oil Pump | | 36.5*50.5*7 | MUSASHI | M4631 | '90.11~'93.8 |
| MAZDA | E SERIES BA ALL | Front wheel | 9958-54-8659 | 48*65*9 | PAYEN | NJ 384 | |
| MAZDA | E SERIES HA 4 CYL Diesel 2977cc | Timing Cover | 0636/4869-10-602 | 51*70*11 | PAYEN | NJ 367 | |
| MAZDA | E SERIES R2 4 CYL Diesel 2184 cc | Crank Shaft Rear | F801/C2-11-399 | 90*110*9 | PAYEN | NJ 325 | |
| MAZDA | E SERIES RF 4 CYL Diesel 1998 cc | Cam Shaft | BP01-10-602 | 30*44*7 | PAYEN | NJ448 | |
| MAZDA | E SERIES S# SD...single tyre | | W001-27-165 | 50*75*12/17 | PAYEN | NJ 486 | |
| MAZDA | E SERIES S# SR.SD...single tyre | | 9958-55-5729 | 55*72*9 | PAYEN | NJ 890 | |
| MAZDA | E SERIES S# | Differential pinion | M005-17-165 | 40*64*12/17.5 | PAYEN | NJ 813 | |
| MAZDA | E SERIES S# SS.SE.S..2WD.double tyre | Rear wheel inner | 9958-55-5782 | 55*78*12 | PAYEN | NJ 588 | |
| MAZDA | E SERIES S# SS.SE.SR.SD...2W | Front wheel | 9958-55-2709 | 52*70*9 | PAYEN | NJ 892 | |
| MAZDA | E SERIES S# SS.SE.SR.SD...4W | Front wheel inner | UC86-33-065A | 65*82*8/14 | PAYEN | NJ 908 | |
| MAZDA | E5 4 cyl (ohc) 1490 cc | Crank Shaft Rear | 0370-11-399 | 70*88*12 | PAYEN | NJ099 | 6/80-84 |
| MAZDA | Engine Timing Gear Cover | Timing Cover | 0187-10-507B | 40*55*8 | MUSASHI | M4521 | '77.8~'83.9 |
| MAZDA | EVB.EXB.EXC double tyre | Rear Wheel Inere | W025-26-154 | 75*121*13 | PAYEN | NJ483 | 71-77 |
| MAZDA | EVB 3t- | Front Wheel | 9958-57-5055 | 75*105*15 | PAYEN | NJ589 | 71-77 |
| MAZDA | Familia | Front Wheel Inner | B00133065 | 52*68*7/13 | MUSASHI | | |
| MAZDA | Familia | Timing Cover | 0221-10602A | 48*70*12 | MUSASHI | | |
| MAZDA | Familia ,323 | Front Wheel Outer | B00133067 | 50*63*6 | MUSASHI | | |
| MAZDA | Familia ,Luce Cosmo Savanna | Front Wheel | 39833065 | 40*54*5 | MUSASHI | | |
| MAZDA | Familia .323(FWD,4WD)...Sedan,Coupe | Engine Cam Shaft | 8-94251-171-0 | 40*52*6 | MUSASHI | | '94.3~ |
| MAZDA | Familia .323(R.W.D.)-FA4 | Crank Shaft Rear | 0370-11-399 | 70*88*12 | MUSASHI | M4546 | '77.8~'83.9 |
| MAZDA | Familia .323(R.W.D.)-FA4 | Front Wheel | 1312-33-065 | 40*54*6 | MUSASHI | M4509 | '76.12~'85 |
| MAZDA | Familia .323(RWD)-FA4 | Differential Pinion | | 32*45*10 | MUSASHI | M4507 | '76.12~'85 |
| MAZDA | Familia .LASER.323(F.W.D.)-BD#,BE#.BF#.BG#. | Differential | F004-27-238 | 35*56*9/15 | MUSASHI | M4542 | '80.5~'89.10 |
| MAZDA | Familia .LASER.323(F.W.D.)-BD#,BE#.BF#.BG#. | Front Wheel Inner | B001-33-065A | 52*68*7/13 | MUSASHI | M4540 | '80.5~'85.1 |
| MAZDA | Familia .LASER.323(F.W.D.)-BD#,BE#.BF#.BG#. | Rear Wheel | B001-26-154B | 40*54*7 | MUSASHI | M4534 | '80.5~'85.12 |

| CAR | MODEL | APPLICATION | OEM NO. | SIZE | DATA acc. | CODE | YEARS |
|-------|--|-----------------------------|---------------|---------------|-----------|--------|-------------|
| MAZDA | Familia .LASER.323(F.W.D.)- BD#.BE#.BF#.BG#. | Transmission Input Shaft | 0613-16-103 | 24*40*8 | MUSASHI | M4556 | '80.5~'89.1 |
| MAZDA | Familia BF BF#...2WD | Differential | 002/03-27-238 | 35*56*9/15 | PAYEN | NJ 452 | |
| MAZDA | Familia FA FA4 | Differentialpinion | 0249-27-018/A | 32*54*10 | PAYEN | NJ 116 | |
| MAZDA | FE 4 cyl (ohc) 1998 cc | Cam Shaft | F801-10-602 | 34*48*7 | PAYEN | NJ324 | 82- on |
| MAZDA | JE V6 cyl (dohc) 2954 cc | Timing Cover | JF01-10-602A | 46*60*7 | PAYEN | NJ978 | 8/88-on |
| MAZDA | JE V6 cyl (ohc) 2954 cc | Timing Cover | JF01-10-602 | 46*60*7 | PAYEN | NJ978 | 87-on |
| MAZDA | KRAFT | Front Wheel | 9-9582-70922 | 70*92*12 | MUSASHI | | |
| MAZDA | Luce Cosmo Savanna Capella | Front Wheel | 9-9585-48629 | 48*62*9 | MUSASHI | | |
| MAZDA | Luce HB HB...5 link sus | Rear wheel | 1011-26-154 | 47*62*9 | PAYEN | NJ 090 | |
| MAZDA | Luce LA ALL | Differential pinion | 0223-27-018 | 40*64*12 | PAYEN | NJ 264 | |
| MAZDA | Luce.929-LA,HB,HC | Crank Shaft Rear | JF01-11-312 | 75*93*9 | MUSASHI | | '86.9~ |
| MAZDA | Luce.929-LA,HB,HC | Crank Shaft Rear | F801-11-399 | 90*110*9 | MUSASHI | M4571 | '83.9~'86.9 |
| MAZDA | Luce.929-LA,HB,HC | Diff Side | M0A2-27-238 | 35*56*9/15 | MUSASHI | M4542 | '81.8~'86.9 |
| MAZDA | Luce.929-LA,HB,HC | Diff Side | F001-27-238 | 35*56*9/15 | MUSASHI | M4542 | '81.8~'86.9 |
| MAZDA | Luce.929-LA,HB,HC | Differential Diff | | 40*75*11/16.5 | MUSASHI | M4634 | '86.9~'91 |
| MAZDA | Luce.929-LA,HB,HC | Engine Cam Shaft (R) | | 38*52*7 | MUSASHI | | '86.9~'91 |
| MAZDA | Luce.929-LA,HB,HC | Front Wheel | 0398-33-065 | 40*54*6 | MUSASHI | M4509 | '77.9~'82 |
| MAZDA | Luce.929-LA,HB,HC | Timing Cover | FE01-10-602 | 34*48*7 | MUSASHI | M4570 | '83.9~'86.9 |
| MAZDA | Luce.929-LA,HB,HC | Timing Cover | JF01-10-602A | 46*60*7 | MUSASHI | | '86.9~ |
| MAZDA | Luce.929-LA,HB,HC | Timing Cover | 4869-10-602 | 51*70*11 | MUSASHI | M4572 | '80.8~'83 |
| MAZDA | Luce.929-LA,HB,HC | Timing Cover | SE08-10-602 | 51*70*11 | MUSASHI | M4572 | '80.8~'83 |
| MAZDA | Luce.929-LA,HB,HC | Transmission | 8599-17-335 | 35*48*10 | MUSASHI | | '80.8~'83.6 |
| MAZDA | Luce-929---HC....JF | Engine Oil Pump | | 43*55*6 | MUSASHI | ※ | '86.9~'91 |
| MAZDA | Luce-929--- HC....JF(3000cc) | Engine Cam Shaft (L) | | 65*81*7 | MUSASHI | ※ | '86.9~'91 |
| MAZDA | Luce-929--- HC...JF(3000cc) | Engine Cam Shaft (R) | | 38*52*7 | MUSASHI | ※ | '86.9~'91 |
| MAZDA | Luce-929---LA | Drive Pinion | M054-27-165 | 40*64*12/17.5 | MUSASHI | M4548 | '83.9~'90.3 |
| MAZDA | MA 4 cyl (ohc) 1970 cc | Timing Cover | 0221-10-602B | 48*70*12 | PAYEN | NJ042 | 78-on |
| MAZDA | MA 4 cyl (ohc) 1970 cc | Timing Cover | 0221-10-602A | 48*70*12 | PAYEN | NJ042 | 78- on |
| MAZDA | MX3 B6 4 CYL (DOHC) 1597 cc | Cam Shaft | E43E-6700D | 34*48*7 | PAYEN | NJ 324 | |
| MAZDA | NA 4 cyl (ohc) 1586 cc | Timing Cover | D27Z-6700A | 48*70*12 | PAYEN | NJ042 | 71-75 |
| MAZDA | PORTER CAB- PC4D,PC56T | Front Wheel | P001-33-065 | 32*45*8 | MUSASHI | M6406 | '86.3~'89 |
| MAZDA | PORTER CAB- PC4D,PC56T | Rear Shaft | 0187-26-154 | 42*55*9 | MUSASHI | M4522 | '78~'89 |
| MAZDA | PROCEED(PE) | Front Wheel | 0603-33065 | 45*65*5 | MUSASHI | | |
| MAZDA | PROCEED(PE) | Rear Wheel | 0603-26154 | 35*55*11 | MUSASHI | | |
| MAZDA | PROCEED.B1600,B 1800-PE | Drive Pinion | 0604-27-018 | 40*75*12 | MUSASHI | M4517 | '77~ |
| MAZDA | PROCEED.B1600,B 1800-PE | Front Wheel | 3900-33-065 | 45*65*5 | MUSASHI | M4551 | '77~ |
| MAZDA | PROCEED.B1600,B 1800-PE | Front Wheel | 0603-33-065 | 45*65*5 | MUSASHI | M4551 | '77~ |
| MAZDA | PROCEED.B1600,B 1800-PE | Timing Cover | 0221-10-602B | 48*70*12 | MUSASHI | M4504 | '77~ |

| CAR | MODEL | APPLICATION | OEM NO. | SIZE | DATA acc. | CODE | YEARS |
|-------|---|-----------------------------|------------------|--------------|-----------|--------|--------------|
| MAZDA | R2 4 cyl Diesel 2184 cc | Timing Cover | SE08-10-602 | 51*70*11 | PAYEN | NJ367 | |
| MAZDA | RE12A rotary Eng. 2*573 cc | Timing Cover | 0820-10-605 | 42*60*9 | PAYEN | NJ358 | 81-85 |
| MAZDA | RF 4 cyl Diesel 1998 cc | Timing Cover | RF01-12-602 | 30*44*7 | PAYEN | NJ448 | 9/82-3/85 |
| MAZDA | RX7 FC FC3 | Front wheel | FB01-33-065A | 52*63*8 | PAYEN | NJ 662 | |
| MAZDA | RX7 FC FC3 | Rear wheel | FB01-26-065A | 58*72*8 | PAYEN | NJ 906 | |
| MAZDA | RX7 RE12A ROTARY ENG. | Crank Shaft Rear | 1668-10-556A | 68*95*13 | PAYEN | NJ 031 | |
| MAZDA | Savanna.RX-7-SA22C,FC3# | Front Wheel | 0398-33-085 | 40*54*6 | MUSASHI | M4509 | '78.3~'85 |
| MAZDA | Savanna.RX-7-SA22C,FC3# | Front Wheel | FB01-33-065A | 52*63*8 | MUSASHI | | '85.10~ |
| MAZDA | SD single tyre | Rear wheel Inner | 0604-26-154 | 58*80*9 | PAYEN | NJ628 | 6/83-on |
| MAZDA | SD single tyre | Rear wheel Outer | 0604-26-184 | 42*65*9 | PAYEN | NJ629 | 6/82-on |
| MAZDA | SR.SD double tyre | Rear wheel Outer | 1416-26-157 | 38*45*8 | PAYEN | NJ427 | 6/83- on |
| MAZDA | SR.SD double tyre | Rear wheel Inner | 9958-56-5903 | 65*90*13 | PAYEN | NJ 395 | |
| MAZDA | SR.SD single tyre | Rear wheel Inner | 0603-26-154 | 35*55*8 | PAYEN | NJ092 | 9/85-9/87 |
| MAZDA | SR.SD single tyre | Rear wheel Outer | 0603-26-157 | 48*70*9 | PAYEN | NJ091 | 6/83-9/87 |
| MAZDA | SS.SE.SR.SD | Front Wheel | S113-33-067 | 52*70*9 | PAYEN | NJ892 | 6/83-on |
| MAZDA | T SERIES Bus W# WVW | Rear wheel inner | 0600/W025-26-254 | 75*121*13 | PAYEN | NJ 483 | |
| MAZDA | T3000,T3500 Bus-TA3H,WVW | Drive Pinion | 0557-27-018 | 45*75*12 | MUSASHI | M4511 | '77.8~'81 |
| MAZDA | T3000,T3500 Bus-TA3H,WVW | Front Wheel | 0559-33-065 | 70*88*12 | MUSASHI | M4513 | '77.8~'81 |
| MAZDA | T3000,T3500 Bus-TA3H,WVW | Rear Wheel Inner | W025-26-154 | 75*121*13 | MUSASHI | M4536 | '81.10~ |
| MAZDA | T3000,T3500 Bus-TA3H,WVW | Rear Wheel Inner | 0600-26-154 | 75*121*13 | MUSASHI | M4514 | '77.8~'81 |
| MAZDA | T3000,T3500 Bus-TA3H,WVW | Rear Wheel Outer | W025-26-157 | 43*50*9 | MUSASHI | M4541 | '81.10~ |
| MAZDA | T3000,T3500 Bus-TA3H,WVW | Transmission Front | 0155-16-103 | 30*44*9 | MUSASHI | M4553 | '77.8~'76.7~ |
| MAZDA | T3000,T3500 Bus-TA3H,WVW | Transmission Rear | 9958-64-0621 | 40*62*11 | MUSASHI | M4523 | '77.8~'81 |
| MAZDA | TA2X | Transmission | 0727-17-335 | 50*72*12 | PAYEN | NJ291 | 4/76-80 |
| MAZDA | TA3H | Front Wheel | 0559-33-065 | 70*88*12 | PAYEN | NJ599 | 8/77-81 |
| MAZDA | TA3H | Transmission | 0155-16-103 | 30*44*9 | PAYEN | NJ598 | 8/77-81 |
| MAZDA | TA3H | Transmission | 9958-64-0621 | 40*62*11 | PAYEN | NJ414 | 8/77-81 |
| MAZDA | TA3H double tyre | Rear Wheel Inner | 0600-26-154 | 75*121*13 | PAYEN | NJ483 | 8/77-81 |
| MAZDA | Titan | Diff Drive Pinion | 10727018 | 48*70*12 | MUSASHI | | |
| MAZDA | Titan | Diff Drive Pinion | Y-001-27165 | 62*104*12/20 | MUSASHI | | |
| MAZDA | Titan | Engine Timing Gear Cover | | 60*81*11 | MUSASHI | M4639 | '89.5~ |
| MAZDA | Titan | Rear Wheel Inner | 1304-26-154 | 90*135*15 | MUSASHI | M4533 | '86.3~'89.5 |
| MAZDA | Titan | Rear Wheel Inner | W029-26-154 | 90*135*15 | MUSASHI | M4533 | '86.3~'89.5 |
| MAZDA | Titan | Rear Wheel Outer | 141626157 | 38*45*8 | MUSASHI | | |
| MAZDA | Titan | Timing Cover | 15510602 | 50*72*12 | MUSASHI | | |
| MAZDA | Titan | Transmission | 0727-16-213 | 33*50*10 | MUSASHI | | '75.9~ |
| MAZDA | Titan | Transmission | 9-9586-45682 | 45*68*12 | MUSASHI | M4524 | |
| MAZDA | Titan | Transmission | 9-9586-40621 | 40*62*12 | MUSASHI | | |
| MAZDA | Titan(T2500,T3000,T3500,T4000)-EVB,EXB,EXC,EXR,TA3H,TA2X,WE,W | Front Wheel | W029-33-065 | 65*100*12 | MUSASHI | M4535 | '86.3~'89.5 |
| MAZDA | Titan,KRAFT | Rear Wheel Outer,Rear Wheel | 0604-26184 | 42*65*9 | MUSASHI | | |
| MAZDA | Titan-WE...4100 | Engine Timing Gear Cover | | 60*79*11 | MUSASHI | M4641 | '80.10~'87 |

| CAR | MODEL | APPLICATION | OEM NO. | SIZE | DATA acc. | CODE | YEARS |
|----------|--|--------------------------------|-----------------|---------------|-----------|--------|--------------|
| MAZDA | Truck | Timing Cover | 04865-05500 | 55*78*12 | MUSASHI | | |
| MAZDA | WVL | Rear Wheel Inner | W025-26-157 | 43*50*9 | PAYEN | NJ721 | 10/81-on |
| MAZDA | | Crank Shaft Rear | SE08-11-399 | 102*125*13 | MUSASHI | M4573 | '77.3~'89.5 |
| MAZDA | | Crank Shaft Rear | C370-11-399 | 70*88*12 | MUSASHI | M4546 | '80.5~'86.12 |
| MAZDA | | Crank Shaft Rear | FE5H-11-399 | 90*110*9 | MUSASHI | M4571 | '83.9~'83.6 |
| MAZDA | | Drive Pinion | 1358-27-018 | 40*75*12 | MUSASHI | M4517 | '76.7~'80 |
| MAZDA | | Drive Pinion | P005-27-165 | 40*75*12/17.5 | MUSASHI | | '83.9~'90.7 |
| MAZDA | | Drive Pinion | P017-27-165 | 40*75*12/17.5 | MUSASHI | | '83.9~'90.7 |
| MAZDA | | Drive Pinion | 0527-27-018 | 45*75*12 | MUSASHI | M4511 | '77.3~'80 |
| MAZDA | | Drive Pinion | W001-27-165 | 50*75*12/17 | MUSASHI | M4544 | '83.6~ |
| MAZDA | | Rear Wheel Outer | 0604-26-154 | 58*80*9 | MUSASHI | M4516 | '71~'80 |
| MAZDA | | Timing Cover | V101-10-602 | 60*79*11 | MUSASHI | | '80.10~'87 |
| MAZDA | | Timing Cover | TF01-10-602 | 60*81*11 | MUSASHI | | '89.5~ |
| MAZDA | | Transmission | 1363-17-335 | 40*62*11 | MUSASHI | M4523 | '76.7~'80 |
| MAZDA | | Transmission | 0727-17-335 | 50*72*12 | MUSASHI | M4560 | '75.9~'80 |
| MAZDA | | | F807-18-216 | 13*22*6 | PAYEN | NJ905 | |
| MAZDA | | | FA54-33-065 | 40*54*6 | PAYEN | NJ919 | |
| MAZDA | | | 1312-33-065 | 40*54*6 | PAYEN | NJ919 | |
| MAZDA | | | 0604-27-018 | 40*75*12 | PAYEN | NJ043 | |
| MAZDA | | | F92Z-1177B | 42*58*7 | PAYEN | NJ179 | |
| MAZDA | | | F32Z-6700A | 43*55*6 | PAYEN | NJ177 | |
| MAZDA | | | H001-33-065 | 52*63*8 | PAYEN | NJ920 | |
| MAZDA | | | B00133075 | 52*68*7/13 | MUSASHI | | |
| MAZDA | | | W001-33-065 | 65*90*13 | PAYEN | NJ820 | |
| MAZDA | | | 9958-60-8166 | 8*16*6 | PAYEN | NJ807 | |
| MAZDA | ALL | Transmission | 32113-H3100 | 24*40*8 | PAYEN | NJ084 | 10/75-on |
| MAZDA | B6 4 cyl (dohc) 1597 cc | Timing Cover | 8630-10-602 | 30*44*7 | PAYEN | NJ448 | 8/91-on |
| MAZDA | F8 4 cyl (ohc) 1789 cc | Timing Cover | FE01-10-602 | 34*48*7 | PAYEN | NJ324 | 87-on |
| MAZDA | Familia | Front Wheel | 187-33065A | 40*54*5 | MUSASHI | | |
| MAZDA | FE 4 cyl (ohc) 1998 cc | Crank Shaft Rear | FE5H-11-399 | 90*110*9 | PAYEN | NJ325 | 82- on |
| MAZDA | FE 4 cyl (ohc) 1998 cc | Timing Cover | FE02-10-602 | 34*48*7 | PAYEN | NJ324 | 82-on |
| MAZDA | HB 5 link sus. | Rear Wheel | 0437-17-335/A | 47*62*9 | PAYEN | NJ090 | 8/81-86 |
| MAZDA | HJ6# | Output shaft front | 90311-48004 | 48*70*12 | PAYEN | NJ042 | 10/82-11/84 |
| MAZDA | Familia .LASER.323(F.W.D.)- BD#.BE#.BF#.BG#. | Rear Wheel | G304-33-065 | 56*68*5/11 | MUSASHI | M4615 | '89.6~ |
| MAZDA | Capella 626(F.W.D.)- | Front Axle | G304-33-065 | 56*68*5/11 | MUSASHI | M4515 | '87.3~'88.1 |
| MAZDA | ALL | Front Wheel | G304-33-065 | 56*68/74*11 | PAYEN | NK034 | 3/87-on |
| MAZDA | 626 GC ALL | Transmission | 0603-16-103 | 27*43*9 | PAYEN | NJ 484 | 9/83-on |
| MAZDA | 929 HB ALL | Differential pnion | M005-27-165 | 40*64*12/17.5 | PAYEN | NJ 813 | |
| MAZDA | | | 010718216A | 16*30*7 | ISI | | |
| MAZDA | MAZDA TITAN WE,WG ◆3500 (TURBO),4100,4600 | Transmission FRONT COVER | 0727-16-213 | 33*50*10 | MUSASHI | | 80.10~95. |
| DAIHATSU | APPLAUSE- A101,A111 | Cam Shaft | 90043-11229-000 | 38*50*8 | MUSASHI | | '89.6~ |
| DAIHATSU | APPLAUSE- A101,A111 | Differential (Engine Side) | 90043-11227-000 | 45*68*12.5/19 | MUSASHI | D4736 | '89.6~ |
| DAIHATSU | APPLAUSE- A101,A111 | Differential (Engine Side) | 90043-11147-000 | 45*68*12.5/19 | MUSASHI | D4736 | '89.6~ |
| DAIHATSU | APPLAUSE- A101,A111 | Differential (Mission Side) | 90043-11148-000 | 45*80*10/16.5 | MUSASHI | D4737 | '89.6~ |
| DAIHATSU | APPLAUSE- A101,A111 | Differential (Mission Side) | 90043-11228-000 | 45*80*10/16.5 | MUSASHI | D4737 | '89.6~ |

| CAR | MODEL | APPLICATION | OEM NO. | SIZE | DATA acc. | CODE | YEARS |
|----------|----------------------------------|--------------------------|--------------------|-------------|-----------|--------|---------------|
| DAIHATSU | APPLAUSE-A101,A111 | Transmission Input Shaft | 90043-10027-000 | 25*35*6 | MUSASHI | D6202 | '89.6~ |
| DAIHATSU | APPLAUSE-A101,A111 | Transmission Input Shaft | 90043-10051-000 | 25*35*6 | MUSASHI | D6202 | '89.6~ |
| DAIHATSU | APPLAUSE-HD.....A1# | Engine Cam Shaft | | 38*50*8 | MUSASHI | D4746 | '89.6~ |
| DAIHATSU | CB 3 CYL (OHC) 993 cc | Timing Cover | 90043-11109 | 32*48*7 | PAYEN | NJ268 | 78-4/83 |
| DAIHATSU | Charade CB 3 CYL (OHC) 993 cc | Timing Cover | 90043-11144 | 34*48*7 | PAYEN | NJ 324 | |
| DAIHATSU | Charade-G10,G11,G30,G10#,G11# | Cam Shaft | 90043-11140-000 | 28*42*8 | MUSASHI | | '83.1~'87.1 |
| DAIHATSU | Charade-G10,G11,G30,G10#,G11# | Cam Shaft | 90043-11210-000 | 38*52*7 | MUSASHI | | '87.1~ |
| DAIHATSU | Charade-G10,G11,G30,G10#,G11# | Crank Shaft Rear | 90043-11222-000 | 58*74*10 | MUSASHI | D4738 | '87.1~ |
| DAIHATSU | Charade-G10,G11,G30,G10#,G11# | Crank Shaft Rear | 90043-11176-000 | 70*92*12 | MUSASHI | T1121 | '84.8~'87.1 |
| DAIHATSU | Charade-G10,G11,G30,G10#,G11# | Crank Shaft Rear | 90043-11230-000 | 80*100*8.5 | MUSASHI | T1180 | '88.1~ |
| DAIHATSU | Charade-G10,G11,G30,G10#,G11# | Crank Shaft Rear | 90311-80003 | 80*100*8.5 | MUSASHI | T1180 | '88.1~ |
| DAIHATSU | Charade-G10,G11,G30,G10#,G11# | Front Wheel (Outer) | 90043-11150-000 | 45*63*7 | MUSASHI | D4710 | '77.10~'86.12 |
| DAIHATSU | Charade-G10,G11,G30,G10#,G11# | Timing Cover | 90043-11211-000 | 34*48*7 | MUSASHI | | '87.1~'90.2 |
| DAIHATSU | Charade-G10,G11,G30,G10#,G11# | Timing Cover | 90043-11144-000 | 34*48*7 | MUSASHI | | '83.1~'90.2 |
| DAIHATSU | Charade-G10,G11,G30,G10#,G11# | Transmission Input Shaft | 90043-10036-000 | 25*35*6 | MUSASHI | D6202 | '83.1~ |
| DAIHATSU | Charmant | Crank Shaft | 90311-70120-000 | 70*92*12 | MUSASHI | T1121 | |
| DAIHATSU | Charmant | Timing Cover | 90311-38002-000 | 38.5*58*11 | MUSASHI | T1060 | |
| DAIHATSU | Charmant | Transmission | 90311-25141-000 | 25*38*7 | MUSASHI | | |
| DAIHATSU | Charmant 3K 4 CYL (OHV) 1166 cc | Crank Shaft Rear | 90043-11176 | 70*92*8.5 | PAYEN | NJ001 | |
| DAIHATSU | Charmant A10.20.30.34.40.55 | Transmission Rear | 90311-32086 | 32*52*11 | PAYEN | NJ 606 | |
| DAIHATSU | Charmant A10.20.30.35.40.55 | Rear wheel | TOYOTA 90311-42055 | 42*55*7 | PAYEN | NJ 052 | |
| DAIHATSU | Charmant A10.20.30.35.40.55 | Trasmission Feont | TOYOTA 90311-25141 | 25*38*7 | PAYEN | NJ 118 | |
| DAIHATSU | Charmant A10.20.30.40.55 | Differential pinion | TOYOTA 90311-38124 | 38*65*12/19 | PAYEN | NJ 017 | |
| DAIHATSU | Charmant A10.30 | Front Wheel | 90043-11206 | 40*52*7 | PAYEN | NJ 011 | |
| DAIHATSU | Charmant-A10,A20,A30,A40,A35,A55 | Cam Shaft | 90311-35003-000 | 35*49*6 | MUSASHI | T1173 | '81.10~'87 |
| DAIHATSU | Charmant-A10,A20,A30,A40,A35,A55 | Crank Shaft Rear | 90311-70001-000 | 70*92*12 | MUSASHI | T1121 | '74~'82.3 |

| CAR | MODEL | APPLICATION | OEM NO. | SIZE | DATA acc. | CODE | YEARS |
|----------|--|-----------------------------|--------------------|---------------|-----------|--------|--------------|
| DAIHATSU | Charmant- A10,A20,A30,A40,A 35,A55 | Crank Shaft Rear | 90311-70004-000 | 70*92*8.5 | MUSASHI | T1172 | '82.3~'87 |
| DAIHATSU | Charmant- A10,A20,A30,A40,A 35,A55 | Front Wheel | 90311-41123-000 | 41*53*7 | MUSASHI | T1074 | '74~'87 |
| DAIHATSU | Charmant- A10,A20,A30,A40,A 35,A55 | Rear Shaft | 90311-42055-000 | 42*55*7 | MUSASHI | T1075 | '74~'87 |
| DAIHATSU | Charmant- A10,A20,A30,A40,A 35,A55 | Timing Cover | 90311-38022-000 | 38.5*58*8.5 | MUSASHI | T1171 | '82.3~'87 |
| DAIHATSU | Charmant- A10,A20,A30,A40,A 35,A55 | Transmission Rear | 90311-32074-000 | 32*52*11 | MUSASHI | T1052 | '74~'87 |
| DAIHATSU | Charmant- A10,A20,A30,A40,A 35,A55 | Transmission Rear | 90311-32010-000 | 32*52*11 | MUSASHI | T1052 | '74~'87 |
| DAIHATSU | CL 3 cyl Diesel 993 cc | CaMm Shaft | 90043-11149 | 28*42*8 | PAYEN | NJ270 | 82-on |
| DAIHATSU | Coaster-RB,BB,HB | Crank Shaft Rear | 90311-95001-000 | 95*115*12 | MUSASHI | T1128 | '72~'89.8 |
| DAIHATSU | CUOREL L55 | Differential | 90043-11105/53 | 35*68*9/15.5 | PAYEN | NJ 667 | |
| DAIHATSU | CUORE- L45,L55,L56,L70,L7 | Crank Shaft Rear | 90043-11095-000 | 58*74*10 | MUSASHI | D4734 | '80.6~'90 |
| DAIHATSU | CUORE- L45,L55,L56,L70,L7 | Differential | 90043-11234-000 | 35*68*9/15.5 | MUSASHI | D6207 | '80.6~'90 |
| DAIHATSU | CUORE- L45,L55,L56,L70,L7 | Differential | 90043-11184-000 | 35*68*9/15.5 | MUSASHI | D6207 | '80.6~'90 |
| DAIHATSU | CUORE- L45,L55,L56,L70,L7 | Differential | 90043-11153-000 | 35*68*9/15.5 | MUSASHI | D6207 | '80.6~'90 |
| DAIHATSU | CUORE- L45,L55,L56,L70,L7 | Differential | 90043-11105-000 | 35*68*9/15.5 | MUSASHI | D6207 | '80.6~'90 |
| DAIHATSU | CUORE- L45,L55,L56,L70,L7 | Front Wheel (Inner) | 90043-11106-000 | 40*64*16 | MUSASHI | D4711 | '80.6~'83.6 |
| DAIHATSU | CUORE- L45,L55,L56,L70,L7 | Front Wheel (Outer) | 90043-11188-000 | 44*63*7/10 | MUSASHI | D6214 | '85.8~'90 |
| DAIHATSU | CUORE- L45,L55,L56,L70,L7 | Front Wheel (Outer) | 90043-11111-000 | 45*63*7 | MUSASHI | D4710 | '80.6~'83.6 |
| DAIHATSU | CUORE- L45,L55,L56,L70,L7 | Rear Wheel Inner | 90043-10042-000 | 38*52*7 | MUSASHI | D6211 | '83.10~'86.8 |
| DAIHATSU | CUORE- L45,L55,L56,L70,L7 | Timing Cover | 90043-11109-000 | 32*48*7 | MUSASHI | D4733 | '80.6~'85.8 |
| DAIHATSU | CUORE- L45,L55,L56,L70,L7 | Transmission Input Shaft | 90043-10045-000 | 20*35*8 | MUSASHI | D4712 | '80.6~'90 |
| DAIHATSU | CUORE- L45,L55,L56,L70,L7 | Transmission Input Shaft | 90043-10026-000 | 20*35*8 | MUSASHI | D4712 | '80.6~'90 |
| DAIHATSU | CUORE- L45,L55,L56,L70,L7 | Transmission Input Shaft | 90043-10045-000 | 20*35*8 | MUSASHI | D4712 | '80.6~'90 |
| DAIHATSU | CUORE- L45,L55,L56,L70,L7 | Transmission Input Shaft | 90043-10026-000 | 20*35*8 | MUSASHI | D4712 | '80.6~'90 |
| DAIHATSU | DELTA | Diff Drive Pinion | 90043-11058-000 | 50*82*12 | MUSASHI | | |
| DAIHATSU | DELTA | Engine Crank Shaft Rear | 90311-95008 | 95*115*9.5/12 | MUSASHI | T1278 | '88.8~ |
| DAIHATSU | DELTA | Engine Timing Gear Cover | | 50*72*9/14 | MUSASHI | T1277 | '88.8~ |
| DAIHATSU | DELTA | Rear Wheel | 90034-11060-000 | 63*80*9 | MUSASHI | | |
| DAIHATSU | DELTA | Rear Wheel | 4111-4325 | 70*112*14/20 | MUSASHI | | |
| DAIHATSU | DELTA | Timing Cover | 90311-50013-000 | 50*72*12 | MUSASHI | T1132 | '72~'84.9 |
| DAIHATSU | DELTA DV B4 CYL DIESEI 2977 cc | Timing Cover | TOYOTA 90311-50049 | 50*72*12 | PAYEN | NJ 239 | |

| CAR | MODEL | APPLICATION | OEM NO. | SIZE | DATA acc. | CODE | YEARS |
|----------|---|-------------------------|--------------------|--------------|-----------|--------|-------------|
| DAIHATSU | DELTA SV DG2 4 CYL DIESEL 2530 | Timing Cover | 90043-11075/112 | 45*62*9 | PAYEN | NJ 276 | |
| DAIHATSU | DELTA SV SV17.23.26 | Transmission rear | 90043-11024/66 | 40*62*10 | PAYEN | NJ 405 | |
| DAIHATSU | DELTA SV SV23.26 | Differential pinion | 90043-11058/59/77 | 50*82*12 | PAYEN | NJ 647 | |
| DAIHATSU | DELTA SV SV23.26 | Rear wheel-inner | 90043-11053 | 70*112*14/20 | PAYEN | NJ 385 | |
| DAIHATSU | DELTA V B 4 CYL DIESEL 2977 cc | Crank Shaft Rear | TOYOTA 90311-95091 | 95*115*12 | PAYEN | NJ 240 | |
| DAIHATSU | DELTA V V 2# 3# | Transmission | 90043-10029/11141 | 30*45*8 | PAYEN | NJ 454 | |
| DAIHATSU | DELTA-5R...V3# | Crank Shaft Rear | 90311-80001-000 | 80*100*12 | MUSASHI | T1129 | '72~'84 |
| DAIHATSU | DELTA-B...DV28 | Timing Cover | 90311-50002-000 | 50*72*12 | MUSASHI | T1132 | '72~'84.9 |
| DAIHATSU | DELTA-SV,DV,V | Drive Pinion | 90043-11059-000 | 50*82*12 | MUSASHI | D4728 | '72~'84.9 |
| DAIHATSU | DELTA-SV,DV,V | Front Wheel | 90043-11102-000 | 68*88*10 | MUSASHI | D4708 | '77.8~'84.9 |
| DAIHATSU | DELTA-SV,DV,V | Rear Wheel Inner | 90043-11053-000 | 70*112*14/20 | MUSASHI | D4700 | '72~'84.9 |
| DAIHATSU | DELTA-SV,DV,V | Rear Wheel Outer | 90043-12023-000 | 55*101*4.7 | MUSASHI | D4729 | '82.3~'84.9 |
| DAIHATSU | DELTA-SV,DV,V | Rear Wheel Outer | 90043-11060-000 | 63*80*9 | MUSASHI | D4715 | '72~'84.9 |
| DAIHATSU | DELTA-SV,DV,V | Transmission | 90311-28004-000 | 28.6*43*6.5 | MUSASHI | T1044 | '72~'84 |
| DAIHATSU | DELTA-SV,DV,V | Transmission | 90311-28003-000 | 28.6*43*6.5 | MUSASHI | T1044 | '72~'84 |
| DAIHATSU | DELTA-SV,DV,V | Transmission | 90311-32106-000 | 32*48*8 | MUSASHI | T1054 | '72~'85.8 |
| DAIHATSU | DELTA-SV,DV,V | Transmission | 90311-32106-000 | 32*48*8 | MUSASHI | T1054 | '72~'85.8 |
| DAIHATSU | DELTA-SV,DV,V | Transmission | 90311-32012-000 | 32*53*7 | MUSASHI | T1193 | '85.8~ |
| DAIHATSU | DELTA-SV,DV,V | Transmission | 90043-11024-000 | 40*62*12 | MUSASHI | D4719 | '72~'77 |
| DAIHATSU | DELTA-SV,DV,V | Transmission | 90043-11066-000 | 40*62*12 | MUSASHI | D4719 | '72~'77 |
| DAIHATSU | DELTA-SV,DV,V | Transmission | 90311-45001-000 | 45*62*9 | MUSASHI | T1076 | '72~'85.8 |
| DAIHATSU | DELTA-SV,DV,V | Transmission | 90043-11100-000 | 45*62*9 | MUSASHI | D4716 | '77.8~'84.9 |
| DAIHATSU | DELTA-SV,DV,V | Transmission | 90311-45001-000 | 45*62*9 | MUSASHI | T1076 | '72~'85.8 |
| DAIHATSU | F20 J15.J16 | Rear Wheel Inner | 90043-11092 | 35*55*11 | PAYEN | NJ274 | 1/76-12/81 |
| DAIHATSU | FEROZA HD 4 CYL (OHC) 1589 cc | Crank Shaft Rear | 90043-11230 | 80*100*8.5 | PAYEN | NJ 360 | |
| DAIHATSU | G10 | Differential | 90043-11153 | 35*68*9/15.5 | PAYEN | NJ 667 | 10/77-12/82 |
| DAIHATSU | G10 . G11. G30 | Front Wheel | 90043-11106 | 40*64*16 | PAYEN | NJ766 | 10/77-on |
| DAIHATSU | G10 .G11 .G30 | Front Wheel | 90043-11111/50 | 45*63*7 | PAYEN | NJ413 | 10/77-on |
| DAIHATSU | G11.G30.G10#.G11 | Transmission | 90043-10032 | 24*35*6 | PAYEN | NJ751 | 1/83-on |
| DAIHATSU | HI JET- EB,EF#..S8#,100,11 0,120,130 | Engine Oil Pump | | 32*46*6 | MUSASHI | D6223 | '94.1~ |
| DAIHATSU | HI JET- S38,S40,S60,S65,S 66,S80,S81,S82,S8 | Crank Shaft Rear | 90043-11267-000 | 58*74*10 | MUSASHI | D4734 | '81.4~'90.4 |
| DAIHATSU | HI JET- S38,S40,S60,S65,S 66,S80,S81,S82,S8 | Front Wheel | 90043-11206-000 | 40*52*7 | MUSASHI | T1073 | '76.4~ |
| DAIHATSU | HI JET- S38,S40,S60,S65,S 66,S80,S81,S82,S8 | Front Wheel | 90311-40108 | 40*52*7 | MUSASHI | T1073 | '76.4~ |
| DAIHATSU | HI JET- S38,S40,S60,S65,S 66,S80,S81,S82,S8 | Rear Wheel | 90043-10020-000 | 30*42*8 | MUSASHI | D6201 | '76.4~ |
| DAIHATSU | HI JET- S38,S40,S60,S65,S 66,S80,S81,S82,S8 | Transmission Front | 90043-10035-000 | 25*35*6 | MUSASHI | D6202 | '76.4~ |
| DAIHATSU | HL- JET AB 2 CYL (OHC) 547 cc | Crank Shaft Rear | 90043-11095/222 | 58*74*10 | PAYEN | NJ 269 | |
| DAIHATSU | HL- JET S S40.60.65.66.80.81. 82.83 | Transmission Feont | 90043-10027/32/35/ | 24*35*6 | PAYEN | NJ 751 | |
| DAIHATSU | L71 | Rear wheel -inner | 90043-10020 | 30*42*8 | PAYEN | NJ726 | 8/86-on |
| DAIHATSU | Mira-Cuore- F70,71,75,76 | Wheel Hub Rear Inner | | 52*65*9 | MUSASHI | T1089 | '84.4~'93 |

| CAR | MODEL | APPLICATION | OEM NO. | SIZE | DATA acc. | CODE | YEARS |
|----------|--|---|-----------------|---------------|-----------|--------|-------------|
| DAIHATSU | Mira-Cuore-L45,L55,L56,L70,L71,L2#,L5# | Transmission & Differential Diff Side (Right) | 90043-11271-000 | 39*68*16/22.5 | MUSASHI | D6225 | '90.3~'94.8 |
| DAIHATSU | Mira-Cuore-L55,L56,L70,L71 | Transmission & Differential Diff.Side (Left) | | 35*68*9/15.5 | MUSASHI | D6207 | '80.6~'90 |
| DAIHATSU | ROCKY DL 4 CYL DIESEL 2765 cc | Crank Shaft Rear | 90043-11076 | 95*110*11 | PAYEN | NJ 098 | |
| DAIHATSU | S40,60,65,66,80,81,82,83 | Transmission Feont | 90043-10036 | 24*35*6 | PAYEN | NJ751 | 4/76-on |
| DAIHATSU | S40,60,65,80,82 | Transmission | 90043-11098 | 30*41*10 | PAYEN | NJ727 | 4/76-on |
| DAIHATSU | SV17,18 .1.5T | Rear wheel -outer | 90043-11060 | 63*80*9 | PAYEN | NJ455 | 72-77 |
| DAIHATSU | TAFT . ROCKY-F10,20,50,60,7# | Rear Shaft Inner | 90043-11081-000 | 32*48*8 | MUSASHI | D4732 | '74~'84 |
| DAIHATSU | TAFT . ROCKY-F10,20,50,60,7# | Rear Shaft Outer | 90043-11166-000 | 50*62*9 | MUSASHI | | '84.4~ |
| DAIHATSU | TAFT . ROCKY-F10,20,50,60,7# | Timing Cover | 90043-11092-000 | 35*55*11 | MUSASHI | D4725 | '74~'78 |
| DAIHATSU | TAFT . ROCKY-F10,20,50,60,7# | Timing Cover | 90043-11001-000 | 35*55*11 | MUSASHI | D4725 | '74~'78 |
| DAIHATSU | F7# | Transfer Input | | 45*72*11 | MUSASHI | ※ | '84.4~ |
| DAIHATSU | TAFT-DL....F7# | Engine Cam Shaft | | 44*60*7 | MUSASHI | D4739 | '87.9~ |
| DAIHATSU | TAFT-F10,20,50,60,7# | Differential Pinion (F&R) | | 45*72*12/18 | MUSASHI | | '84.4~ |
| DAIHATSU | TAFT-F10,20,50,60,7# | Transfer Output (F&R) | | 45*62*9/14 | MUSASHI | | '84.4~ |
| DAIHATSU | TAFT-F10,20,50,60,7# | Wheel Hub Rear Outer | 9828-55101 | 52*72*9 | MUSASHI | | '93.5~ |
| DAIHATSU | V1#,2#,3#,4#,5# | Front wheel | 90043-11102 | 68*88*10 | PAYEN | NJ390 | 77-84 |
| DAIHATSU | V1#,20,23,25,26,36,4#,56 | Rear wheel outer | 90043-12023 | 55*101*4.7 | PAYEN | NJ668 | 3/82-84 |
| DAIHATSU | | Crank Shaft Rear | 90043-11076-000 | 95*110*11 | MUSASHI | D4735 | '77.8~'84.9 |
| DAIHATSU | | Timing Cover | 90043-11022-000 | 38*55*8 | MUSASHI | D4727 | '72~'73 |
| DAIHATSU | | | 90043-10035 | 24*35*6 | PAYEN | NJ751 | |
| DAIHATSU | | | 90043-11166 | 50*62*9 | PAYEN | NJ767 | |
| DAIHATSU | | | 132-15389-00 | 6.8*22*6/7 | | | |
| DAIHATSU | H 6 cyl Diesel 3576 cc | Timing Cover | 90311-50049 | 50*72*12 | PAYEN | NJ239 | 72-on |
| DAIHATSU | JY16.30 | Transmission | 90311-45018 | 45*62*9 | PAYEN | NJ261 | 7/72-85 |
| DAIHATSU | JY16.30 | Transmission | 90311-45001 | 45*62*9 | PAYEN | NJ261 | 7/72-85 |
| DAIHATSU | JY16.30 | Transmission | 90311-45018 | 45*62*9 | PAYEN | NJ261 | 7/72-85 |
| DAIHATSU | JY16.30 | Transmission | 90311-45001 | 45*62*9 | PAYEN | NJ261 | 7/72-85 |
| DAIHATSU | | | 90043-11083 | 40*72/77*12 | | | |
| DAIHATSU | HL- JET S S40.60.65.80.82 | Transmission rear | 90043-11098 | 30*41*10 | PAYEN | NJ 727 | 4/76-on |
| DAIHATSU | DAIHATSU DELTA DG◆SV26 | Engine TIMING GEAR COVER | 90043-11022-000 | 38*55*8 | MUSASHI | D4727 | 72.~73. |
| DAIHATSU | DAIHATSU CHARMANT A10,20,30,40◆SED AN | Steering WORM GEAR | 90310-30035 | 30*40*7 | MUSASHI | T1140 | 74.11~81. |
| DAIHATSU | DELTA-SV,DV,V | Transmission | 90311-32106-000 | 34*48*8 | MUSASHI | T1054 | '72~'85.8 |
| HONDA | 4XE1 4 cyl(ohc) 1588 cc | Timing Cover | 894468-6540 | 40*52*6 | PAYEN | NJ449 | 90-on |
| HONDA | 4XE1 4 cyl(ohc) 1588 cc | Timing Cover | 894482-1570 | 40*52*6 | PAYEN | NJ449 | 90-on |
| HONDA | a20a 4 cyl (ohc) 1955 cc | Timing Cover | 91212-PH1-013 | 35*54*8 | PAYEN | NJ311 | 85-87 |
| HONDA | A20A 4 cyl (ohc) 1955 cc | Timing Cover | 91212-PH1-661 | 35*54*8 | PAYEN | NJ311 | 85-87 |
| HONDA | A20A 4 cyl (ohc) 1955 cc | Timing Cover | 91212-PH1-004 | 35*54*8 | PAYEN | NJ311 | 85-87 |

| CAR | MODEL | APPLICATION | OEM NO. | SIZE | DATA acc. | CODE | YEARS |
|-------|--|--|---------------------|---------------|-----------|--------|------------|
| HONDA | A20A 4 cyl (ohc) 1955 cc | Timing Cover | 91212-PD2-004 | 35*54*8 | PAYEN | NJ311 | 85-87 |
| HONDA | AC.AD | Clutch Case | 91205-PC8-934 | 38*54*8/11.5 | PAYEN | NJ732 | 6/83-5/85 |
| HONDA | AC.AD | Clutch Case | 91205-PC8-935 | 38*54*8/11.5 | PAYEN | NJ732 | 6/83-5/85 |
| HONDA | AC.AD drum brake | Rear Wheel | 91252-692-083 | 42*56.2*6 | PAYEN | NJ526 | 6/83-5/85 |
| HONDA | AC.AD drum brake | rRear Wheel | 91252-692-005 | 42*56.2*6 | PAYEN | NJ526 | 6/83-5/85 |
| HONDA | ACCORD-CA2,3 | Transmission & Differential Converter Case | | 40*62*8/11.5 | MUSASHI | A4849 | '85.5~'89 |
| HONDA | ACCORD- F18B,20B,22B,H22 A...CD3,4,5,6,7,8 | Engine Oil Pump (B) | | 27*40*8 | MUSASHI | A4867 | '93.9~ |
| HONDA | ACCORD- SJ,SV,SM,SY,SZ,A C,AD,CA,CB | Rear Wheel | 91252-634-003/5 | 42*60*7 | MUSASHI | A4802 | '76.4~'81 |
| HONDA | ACTY EH 2 CYL (OHC) 545 cc | Crank Shaft Rear | 91214-679-003/04/14 | 65*88*12 | PAYEN | NK102 | |
| HONDA | ACTY T ALL | Rear wheel Inner | 91252-SC2-015 | 42*55*7 | PAYEN | NJ 201 | |
| HONDA | ALL | Front Wheel | 909724-0230 | 65*85*10 | PAYEN | NJ394 | 5/85-on |
| HONDA | ALL | Rear Wheel Outer | 909724-0640 | 48*70*9.5 | PAYEN | NJ100 | 1/81-10/88 |
| HONDA | ASCOT.ASCOT INNOVA.RAFAGA- CB,CC,CE | Engine Cam Shaft | 912516-92005 | 28*42*8 | MUSASHI | A4855 | '89.9~'95 |
| HONDA | B20A 4 cyl (dohc) 1958 cc | Crank Shaft Rear | 91214-PH3-751 | 80*100*10 | PAYEN | NJ312 | 85-on |
| HONDA | B20A 4 cyl (dohc) 1958 cc | Crank Shaft Rear | 91214-PR4-A01 | 80*100*10 | PAYEN | NJ312 | 85-on |
| HONDA | B20A 4 cyl (dohc) 1958 cc | Crank Shaft Rear | 91214-PH1-661 | 80*100*10 | PAYEN | NJ312 | 85-on |
| HONDA | B20A 4 cyl (dohc) 1958 cc | Crank Shaft Rear | 91214-PH1-004 | 80*100*10 | PAYEN | NJ312 | 85-on |
| HONDA | B20A 4 cyl (dohc) 1958 cc | Crank Shaft Rear | 91214-PH1-003 | 80*100*10 | PAYEN | NJ312 | 85-on |
| HONDA | B20A 4 cyl (dohc) 1958 cc | Crank Shaft Rear | 91214-PE1-721 | 80*100*10 | PAYEN | NJ312 | 85-on |
| HONDA | B20A 4 cyl (dohc) 1958 cc | Crank Shaft Rear | 91214-PD2-004 | 80*100*10 | PAYEN | NJ312 | 85-on |
| HONDA | BALLADE D16A9 4 CYL (DOHC) 1590 | Timing Cover | 91212-PE0-000/03 | 31*46*8 | PAYEN | NJ 381 | |
| HONDA | BALLADE Prelude QUINT | Crank Shaft | 91214-634-004 | 74*98*12 | MUSASHI | | |
| HONDA | BALLADE Prelude QUINT | Diff Side(Left) | 91216-634-003 | 22*35*7 | MUSASHI | | |
| HONDA | BALLADE Prelude QUINT | Diff Side(Left) | 91216-PA0-003 | 22*35*7 | MUSASHI | | |
| HONDA | BALLADE- SS,ST,AJ,AK | Cam Shaft | 91213-PH1-103 | 29*45*8 | MUSASHI | | '83.10~'86 |
| HONDA | BALLADE- SS,ST,AJ,AK | Crank Shaft Rear | 91214-634-003/5 | 74*98*12 | MUSASHI | | '80.8~'83 |
| HONDA | BALLADE- SS,ST,AJ,AK | Crank Shaft Rear | 91214-PE1-721 | 80*100*10 | MUSASHI | | '83.10~'86 |
| HONDA | City A AA | Transmission | 91216-634-003/05 | 22*35*7 | PAYEN | NJ778 | |
| HONDA | City A AA100.120 | Transmission case | 91205-611-003/05 | 35*56*8/12.5 | PAYEN | NJ 915 | |
| HONDA | City ER 4 CYL (OHC) 1231cc | Crank Shaft Rear | 91214-634-003/04/05 | 74*98*12 | PAYEN | NJ 073 | |
| HONDA | City-AA, VF, GA | Crank Shaft Rear | 91214-PH1-004/013 | 80*100*10 | MUSASHI | | '86.10~ |
| HONDA | Civic D13B 4 CYL (OHC) 1343 cc | Cam Shaft | 91213-PC6-000/03 | 29*45*8 | PAYEN | NJ 313 | |
| HONDA | Civic S SF.SC | Front wheel outer | 91251-634-000/03/05 | 45*93*5.8/7.8 | PAYEN | NJ 074 | |
| HONDA | Civic S SF.SC | Rear wheel | 91252-634-003/05 | 42*60*7 | PAYEN | NJ 077 | |

| CAR | MODEL | APPLICATION | OEM NO. | SIZE | DATA acc. | CODE | YEARS |
|-------|---|--|---------------------|-----------------|-----------|--------|-------------|
| HONDA | Civic SC,SF,SK,SL,SP,S R,SS,ST,VB,VC,VJ, WD,AG,AH,AJ,AK,A R,AT,EF | Rear Wheel | 91252-SC2-013/5 | 42*55*7 | MUSASHI | A4839 | '84.9~'87 |
| HONDA | Civic SC,SF,SK,SL,SP,S R,SS,ST,VB,VC,VJ, WD,AG,AH,AJ,AK,A R,AT,EF | Transmission Input Shaft | 91216-PH8-0031/5 | 26*41*7 | MUSASHI | | |
| HONDA | Civic V VB | Rear wheel | 91253-663-003/05/15 | 42*62*7 | PAYEN | NJ 527 | |
| HONDA | Civic-SL,SS,SR,ST | Wheel Hub Front Outer | 91251692013/5 | 45*72.2*7.5/8.5 | MUSASHI | A4804 | '79.7~'83 |
| HONDA | Concerto Domani MA1,2...ZC(PGM- FI) | Transmission & Differential Converter Case | | 40*56*8/11.5 | MUSASHI | A4858 | '88.6~'92 |
| HONDA | CRX EW 4 CYL (OHC) 1488 cc | Timing Cover | 91212-PE0-662 | 31*46*8 | PAYEN | NJ 381 | |
| HONDA | DA5,6,7(PGM-F1),8 | Transmission | 91205-PG1-003 | 40*62*8/11.5 | PAYEN | NK065 | 4/89-on |
| HONDA | EF 4 cyl (ohc) 1599 cc | Cam Shaft | 91203-PA5-004 | 27*43*9 | PAYEN | NJ254 | 76-79 |
| HONDA | EG 4 cyl (ohc) 1599 cc | Crank Shaft Rear | 91214-PA5-004 | 74*98*12 | PAYEN | NJ073 | 76-78 |
| HONDA | EG 4 cyl (ohc) 1599 cc | Timing Cover | 91212-PA5-004 | 35*50*8 | PAYEN | NJ072 | 76-78 |
| HONDA | EH2 cyl(ohc) 545 cc | Crank Shaft Rear | 91214-PE9-004 | 65*88*12 | PAYEN | NK102 | 78-on |
| HONDA | EY 4 cyl (ohc) 1598 cc | Timing Cover | 91212-PH1-003 | 35*54*8 | PAYEN | NJ311 | #NAME? |
| HONDA | Integra ZC 4 CYL (DOHC) 1590 cc | Timing Cover | 91212-PE0-000/03 | 31*46*8 | PAYEN | NJ 381 | |
| HONDA | Integra-QUINT- ZC(DOHC)...AV,DA | Engine Oil Pump | 91212-PE0-003 | 31*46*8 | MUSASHI | A4824 | '85.1~'87.9 |
| HONDA | KA(MSC) except flat low | Rear Wheel Inner | 909724-0350 | 40*60*10 | PAYEN | NJ475 | 77-5/84 |
| HONDA | KA except flat low | Rear Wheel Inner | 909724-0220 | 52*72*7.5 | PAYEN | NJ474 | 75-5/84 |
| HONDA | KAD | Differential Pinion | 909724-0060 | 45*78*12/25.5 | PAYEN | NJ570 | 75-76 |
| HONDA | Legend C20A,C25A,C27A,C 32A...CA# | Engine Crank Shaft Rear | | 80*98*10 | MUSASHI | ※ | '85.10~ |
| HONDA | LEGEND C25A V6 CYL (OHC) 2493 cc | Crank Shaft Rear | 91214-PH7-003/13 | 80*98*10 | PAYEN | NJ 675 | |
| HONDA | LEGEND C25A V6 CYL (OHC) 2493 cc | Timing Cover | 91212-PH7-003/13 | 41*56*8 | PAYEN | NK 023 | |
| HONDA | Legend KA | Cam Shaft | 91213-PL2-003 | 35*50*8 | MUSASHI | | '85.11~ |
| HONDA | Legend KA | Cam Shaft | 91214-PH7-004/013 | 35*50*8 | MUSASHI | | '85.11~ |
| HONDA | Legend KA | Oil Pump | 91212-PH7-013 | 41*56*8 | MUSASHI | | '85.11~ |
| HONDA | LEGEND KA KA | Clutch Case | 91206-PG2-005 | 40*56*9/12.5 | PAYEN | NK 067 | |
| HONDA | ODYSSEY-RA | Differential (ATM) Converter Case(A) | | 44*68*8 | MUSASHI | | '94.10~ |
| HONDA | ODYSSEY-RA | Differential (ATM) Mission Case | | 40*66*8/11.5 | MUSASHI | A4865 | '94.10~ |
| HONDA | ODYSSEY-RA | Engine Cam Shaft | 912516-92003 | 28*42*8 | MUSASHI | A4855 | '94.10~ |
| HONDA | PF50.60 | Transmission | 909724-0040 | 35*49.2*12.5 | PAYEN | NJ453 | 75-on |
| HONDA | Prelude | Engine Cam Shaft | 912516-92013 | 28*42*8 | MUSASHI | A4855 | '91.9~ |
| HONDA | Prelude A20A 4 CYL (OHC) 1955 cc | Timing Cover | 9121-PC6-003 | 35*54*8 | PAYEN | NJ313 | |
| HONDA | Prelude ET 4 CYL (OHC) 1829 cc | | 91213-PD2-004 | 29*45*8 | PAYEN | NJ 313 | |
| HONDA | Prelude-AN,AB,BA | Crank Shaft Front | 91212-611-003 | 35*50*8 | MUSASHI | A4803 | '78.11~'82 |
| HONDA | Prelude-AN,AB,BA | Crank Shaft Front | 91212-PC6-003 | 35*54*8 | MUSASHI | A4831 | '82.11~'87 |
| HONDA | Prelude-AN,AB,BA | Crank Shaft Front | 91212-PD2-004 | 35*54*8 | MUSASHI | A4831 | '82.11~'87 |

| CAR | MODEL | APPLICATION | OEM NO. | SIZE | DATA acc. | CODE | YEARS |
|-------|---------------------------------------|--|---------------------|-----------------|-----------|--------|--------------|
| HONDA | Prelude-AN,AB,BA | Crank Shaft Rear | 91214-PD2-004 | 80*100*10 | MUSASHI | | '82.11~'87.4 |
| HONDA | Prelude-AN,AB,BA | Crank Shaft Rear | 91214-PC7-003 | 80*100*10 | MUSASHI | | '82.11~'87.4 |
| HONDA | Prelude-AN,AB,BA | Transmission | 91206-689-003/5 | 35*76*9/12.5 | MUSASHI | A4814 | '78.11~'87 |
| HONDA | Prelude-AN,AB,BA | Transmission | 91205-PX5-000 | 40*58*8/11.5 | MUSASHI | | '89.11~ |
| HONDA | Prelude-AN,AB,BA | Transmission | 91205-PC8-003/5 | 40*76*9/12.5 | MUSASHI | | '85.7~'87 |
| HONDA | Prelude-BB# | Transmission & Differential Input Shaft | | 28*41*7 | MUSASHI | A4845 | '91.9~ |
| HONDA | Prelude-SN,AB,BA,BB | Transmission & Differential Mission Case | 91212611003 | 40*58*8/11.5 | MUSASHI | A4854 | '89.11~'91.9 |
| HONDA | QUINT.Integra-SU,AV,DA | Cam Shaft | 91203-611-003/4 | 27*43*9 | MUSASHI | A4819 | '85.1~'89 |
| HONDA | QUINT.Integra-SU,AV,DA | Cam Shaft | 91203-PG6-004 | 27*43*9 | MUSASHI | A4819 | '85.1~'89 |
| HONDA | QUINT.Integra-SU,AV,DA | Transmission Input Shaft | 91216-PA0-003/5 | 22*35*7 | MUSASHI | A4811 | '85.1~'89 |
| HONDA | QUINTET A AV | Clutch Case | 91205-PC8-931/32 | 38*54*8/11.5 | PAYEN | NJ 732 | |
| HONDA | QUINTET S SU | Front wheel outer | 91251-692-003/05 | 45*72.2*7.5/8.5 | PAYEN | NJ 464 | |
| HONDA | RIUMPH ACCLAIM EN4 4CYL (OHC) 1335 cc | Cam Shaft | 91203-611-000/03/04 | 27*43*9 | PAYEN | NJ 254 | |
| HONDA | SM Chassis no.1200001 SV.SY | Front Wheel (Inner) | 91251-692-015 | 45*72.2*7.5/8.5 | PAYEN | NJ464 | 7/80-83 |
| HONDA | ST-70,C90ZC. | RETEN DE | 91203-035-000 | 17*29*5 | | | |
| HONDA | SV.SY | Front Wheel | 91251-692-013 | 45*72.2*7.5/8.5 | PAYEN | NJ464 | 7/80-83 |
| HONDA | Today-JW,JA | Cam Shaft | 91203-PG6-003 | 27*43*9 | MUSASHI | A4819 | '85.7~'87.4 |
| HONDA | TRIUMPH ACCLAIM EN4 4CYL (OHC) 1335 | Timing Cover | 91212-611-003/04 | 35*50*8 | PAYEN | NJ 072 | |
| HONDA | Vigor.Inspire | Engine Cam Shaft | 91250SA2003 | 29*43*8 | MUSASHI | A4859 | '89.10~'95 |
| HONDA | Vigor-SZ,AD,CA,CB | Cam Shaft | 91213-PR3-003/4 | 29*43*8 | MUSASHI | | '89.10~ |
| HONDA | Vigor-SZ,AD,CA,CB | Cam Shaft | 91213-PE1-721 | 29*45*8 | MUSASHI | | '83.6~'89 |
| HONDA | Vigor-SZ,AD,CA,CB | Cam Shaft | 91213-PD2-004 | 29*45*8 | MUSASHI | | '82.11~'87.4 |
| HONDA | Vigor-SZ,AD,CA,CB | Cam Shaft | 91213-PC6-003 | 29*45*8 | MUSASHI | | '82.11~'87.4 |
| HONDA | Vigor-SZ,AD,CA,CB | Clutch Case | 91201-PW5-015 | 50*70*11 | MUSASHI | | '89.10~ |
| HONDA | | Cam Shaft | 91213-661-004 | 27*43*9 | MUSASHI | A4819 | '85.7~'87.4 |
| HONDA | | Cam Shaft | 91213-PT0-003/4 | 28*42*8 | MUSASHI | | '89.9~ |
| HONDA | | Crank Shaft Front | 91212-PA5-004 | 35*50*8 | MUSASHI | A4803 | '75~'83 |
| HONDA | | Crank Shaft Rear | 91214-PC6-013 | 80*100*10 | MUSASHI | | '83.6~'89.9 |
| HONDA | | | 91206-PR8-005 | 39*68*9/15.5 | PAYEN | NJ168 | |
| HONDA | | | 91214-PL2-004 | 80*98*10 | PAYEN | NJ675 | |
| HONDA | 4ZB1 4 cyl (ohc) 1817 cc | Cam Shaft | 894334-8450 | 30*45*8 | PAYEN | NJ454 | 83-on |
| HONDA | 4ZB1 4 cyl (ohc) 1817 cc | Cam Shaft | 94334845 | 30*45*8 | PAYEN | NJ454 | 83-on |
| HONDA | 4ZB1 4 cyl (ohc) 1817 cc | Timing Cover | 894339-9970 | 40*56*7 | PAYEN | NJ323 | 83-on |
| HONDA | 4ZC1 4 cyl (ohc) 1994 cc | Timing Cover | 94214912 | 40*56*7 | PAYEN | NJ323 | 12/84-on |
| HONDA | RC.RE.RS.RT.RU.R | Front Wheel | 9828-01112/25/65 | 138*152*12 | PAYEN | NJ391 | 69-on |
| HONDA | V | Front Wheel | 9828-01112/25/65 | 138*152*12 | PAYEN | NJ391 | 69-on |
| HONDA | DQ100 6 cyl Diesel 4507 cc | Timing Cover | 18285-5501-00 | 55*72*9 | PAYEN | NJ294 | 69-83 |
| HONDA | JT150.600 w/0 | Front Wheel | 94137233 | 42*64*6 | PAYEN | NJ666 | 3/85-90 |
| HONDA | | | 91202-216-000 | 14*24*5 | | | |
| HONDA | F210 | | 93102-20447 | 20*40*8 | | | |
| HONDA | | | 91214-GK1-004 | 26*34.5*5.5 | | | |
| HONDA | | | 36901-32000 | 33*46*10.5 | | | |
| HONDA | | | 9828-35119 | 35*50*8 | PAYEN | NK113 | |

| CAR | MODEL | APPLICATION | OEM NO. | SIZE | DATA acc. | CODE | YEARS |
|-------|----------------------------------|-------------------|--------------------|--------------|-----------|---------|-----------|
| HONDA | 4FC1 4 cyl Diesel 1995 cc | Timing Cover | 94339997 | 40*56*7 | PAYEN | NJ323 | 81-on |
| HONDA | Prelude S SN | Clutch Case | 91206-PL1-A02 | 35*62*8/11.5 | PAYEN | NJ 731 | |
| HONDA | QUINT.Integra-SU,AV,DA | Transmission Case | 91205-PC8-003/5 | 40*76*9/12.5 | MUSASHI | A4848 | '87.7~ |
| HONDA | | Crank Shaft Front | 9828-80102/5 | 80*105*13 | MUSASHI | H3022 | '70~'81 |
| HONDA | | | 91209-612-000 | 12*22*7 | PAYEN | NK133 | |
| ISUZU | 4BB1 4 cyl Diesel 3595 cc | Crank Shaft Rear | 909924-4330 | 100*135*15 | PAYEN | NJ232 | 76- on |
| ISUZU | 4BB1 4 cyl Diesel 3595 cc | Timing Cover | 909924-5070 | 60*82*12 | PAYEN | NJ231 | 76-on |
| ISUZU | 4BC2 4 cyl Diesel 3268 cc | Crank Shaft Rear | 109625-3200 | 100*135*10 | PAYEN | NJ646 | 11/85-on |
| ISUZU | 4BC2 4 cyl Diesel 3268 cc | Crank Shaft Rear | 109625-3200 | 100*135*10 | PAYEN | NJ646 | |
| ISUZU | 4BC2 4 cyl Diesel 3268 cc | Crank Shaft Rear | 894107-5680 | 100*135*15 | PAYEN | NJ232 | 11/85-on |
| ISUZU | 4BC2 4 cyl Diesel 3268 cc | Crank Shaft Rear | 94107568 | 100*135*15 | PAYEN | NJ232 | 11/85- on |
| ISUZU | 4HE1-T, 4HF1, | Crank Shaft Front | BZ4219E | 109*137*13 | NOK | BZ4219E | |
| ISUZU | 4XC1 4 cyl (ohc) 1471 cc | Oil Pump | 94124173 | 32*44*6 | PAYEN | NJ875 | 85-on |
| ISUZU | 4XC1 4 CYL (OHC) 1471 cc | Oil Pump | 894124-1730/941241 | 32*44*6 | PAYEN | NJ 875 | |
| ISUZU | 4XE1 4 cyl(ohc) 1588 cc | Timing Cover | 94482157 | 40*52*6 | PAYEN | NJ449 | 90-on |
| ISUZU | 4XE1 4 cyl(ohc) 1588 cc | Timing Cover | 94251171 | 40*52*6 | PAYEN | NJ449 | 90-on |
| ISUZU | 4XE1 4 cyl(ohc) 1588 cc | Timing Cover | 894251-1710 | 40*52*6 | PAYEN | NJ449 | 90-on |
| ISUZU | 4ZC1 4 cyl (ohc) 1994 cc | Cam Shaft | 94215220 | 30*45*8 | PAYEN | NJ454 | 12/84-on |
| ISUZU | 4ZC1 4 cyl (ohc) 1994 cc | Cam Shaft | 894215-2200 | 30*45*8 | PAYEN | NJ454 | 12/84- on |
| ISUZU | 4ZC1 4 cyl (ohc)1994 cc | Cam Shaft Rear | 894235-3690 | 95*118*10 | PAYEN | NJ322 | 6/85-on |
| ISUZU | 4ZC1 4 cyl (ohc)1994 cc | Cam Shaft Rear | 94214913 | 95*118*10 | PAYEN | NJ322 | 12/84- on |
| ISUZU | 4ZD1 4 cyl (ohc) 2254 cc | Cam Shaft | 94327062 | 30*45*8 | PAYEN | NJ454 | 6/85-on |
| ISUZU | 4ZD1 4 cyl (ohc) 2254 cc | Cam Shaft | 894327-0620 | 30*45*8 | PAYEN | NJ454 | 6/85-on |
| ISUZU | 4ZD1 4 cyl (ohc)2254 cc | Crank Shaft Rear | 94235369 | 95*118*10 | PAYEN | NJ322 | 6/85-on |
| ISUZU | 6BG1 6 cyl Diesel 6494 cc | Crank Shaft Rear | 109625-3848 | 105*135*14 | PAYEN | NJ596 | 8/86-on |
| ISUZU | 6BG1 6 cyl Diesel 6494 cc | Crank Shaft Rear | 109625-3840 | 105*135*14 | PAYEN | NJ596 | 8/86-on |
| ISUZU | 6BG1 6 cyl Diesel 6494 cc | Crank Shaft Rear | 109625-3630 | 105*135*14 | PAYEN | NJ596 | 8/86-on |
| ISUZU | 6BG1 6 cyl Diesel 6994 cc | Crank Shaft Rear | 909924-3560 | 105*135*14 | PAYEN | NJ596 | 8/86-on |
| ISUZU | ALL | Front Wheel | 94258894 | 73*90*8 | PAYEN | NJ737 | 6/84-on |
| ISUZU | ALL | Rear Wheel Outer | 94441817 | 48*70*13/18 | PAYEN | NJ984 | 88-on |
| ISUZU | ALL | Rear Wheel Outer | 94021238 | 48*70*9.5 | PAYEN | NJ100 | |
| ISUZU | ASKA 4ZC1 4 CYL (OHC) 1994 cc | Cam Shaft | 894125-2200/942152 | 30*45*8 | PAYEN | NJ 454 | |
| ISUZU | ASKA-JJ | Engine Cam Shaft | | 30*45*8 | MUSASHI | I3657 | '83.4~'89 |
| ISUZU | Bus B SU...except MAB | | 09625-0630 | 68*90*12 | PAYEN | NJ 500 | |
| ISUZU | Bus E ECM.EDM | Front wheel | 209625-1290 | 85*128*11/21 | PAYEN | NJ 393 | |

| CAR | MODEL | APPLICATION | OEM NO. | SIZE | DATA acc. | CODE | YEARS |
|-------|----------------------------------|-----------------------------|-----------------|---------------|-----------|--------|-------------|
| ISUZU | C190 4 cyl Diesel 1951 cc | Crank Shaft Rear | 94026324 | 82*105*13 | PAYEN | NJ265 | 82-on |
| ISUZU | C190 4 cyl Diesel 1951 cc | Crank Shaft Rear | 509625-0360 | 82*105*13 | PAYEN | NJ265 | 82-on |
| ISUZU | C190 4 cyl Diesel 1951 cc | Timing Cover | 94030585 | 65*84*9 | PAYEN | NJ266 | 83-on |
| ISUZU | C223D 4 cyl Diesel 2238 cc | Timing Cover | 509625-028/0830 | 65*84*9 | PAYEN | NJ 266 | |
| ISUZU | C240 4 cyl Diesel 2369 cc | Crank Shaft Rear | 94022595 | 82*105*13 | PAYEN | NJ060 | 70-81 |
| ISUZU | Capella VC 4 CYL (OHC)1769 cc | | 021-10-602/A/B | 48*70*12 | PAYEN | NJ 042 | |
| ISUZU | CVR | Front Wheel | 909924-5620 | 120*140*10.5 | PAYEN | NJ467 | 9/83-on |
| ISUZU | CVR | Front Wheel | 94047449 | 120*140*10.5 | PAYEN | NJ467 | 9/83-on |
| ISUZU | CVR | Front Wheel | 94047455 | 120*140*10.5 | PAYEN | NJ467 | 9/83-on |
| ISUZU | CXH.SSH | Differential Pinion rear | 109625-0460 | 60*103*12/20 | PAYEN | NJ469 | 9/83-on |
| ISUZU | CXH.SSH | Differential Pinion rear | 109625-0480 | 60*103*12/20 | PAYEN | NJ469 | 9/83-on |
| ISUZU | DA120 6 cyl | Timing Cover | 909924-3280 | 70*92*12 | PAYEN | NJ233 | 69 |
| ISUZU | DA120 6 cyl Diesel 6126 cc | Timing Cover | 909924-3270 | 70*92*12 | PAYEN | NJ233 | 69 |
| ISUZU | DA120 6 cyl Diesel 6126 cc | Timing Cover | 109625-1280 | 70*92*12 | PAYEN | NJ233 | 69 |
| ISUZU | DA120 6 cyl Diesel 6126 cc | Timing Cover | 909924-5060 | 70*92*12 | PAYEN | NJ233 | 69 |
| ISUZU | DA120 6 cyl Diesel 6126 cc | Timing Cover | 909924-5580 | 70*92*12 | PAYEN | NJ233 | 69 |
| ISUZU | ELF | Front Wheel | 9-09924-303-0 | 50*65*9 | MUSASHI | | |
| ISUZU | ELF | Transmission | 9-09724-028-0 | 40*68*12 | MUSASHI | | |
| ISUZU | ELF 150 KA KAG | Differential pinion | 909724-0030 | 40*74*10/18.5 | PAYEN | NJ 569 | |
| ISUZU | ELF 150 NHR NHR...except flat | Rear wheel Inner | 509625-0920 | 40*60*10 | PAYEN | NJ 475 | |
| ISUZU | ELF 150 WHR WHR...except flat | Rear wheel Inner | 909724-0220 | 52*72*7.5 | PAYEN | NJ 474 | |
| ISUZU | ELF 150(1t~1.5t)- KA,NHR,WHR | Crank Shaft Rear | 9-09924-449-0 | 82*105*13 | MUSASHI | I3562 | '75~'84.5 |
| ISUZU | ELF 150(1t~1.5t)- KA,NHR,WHR | Crank Shaft Rear | 8-94235-369-0 | 95*118*10 | MUSASHI | I3612 | '84.6~ |
| ISUZU | ELF 150(1t~1.5t)- KA,NHR,WHR | Crank Shaft Rear | 8-84214-913-0 | 95*118*10 | MUSASHI | I3612 | '84.6~ |
| ISUZU | ELF 150(1t~1.5t)- KA,NHR,WHR | Drive Pinion | 9-09724-003-0 | 40*74*10/18.5 | MUSASHI | I3525 | '77~'84.5 |
| ISUZU | ELF 150(1t~1.5t)- KA,NHR,WHR | Drive Pinion | 9-00724-006-0 | 45*78*11/18 | MUSASHI | I3511 | '75~'84.6 |
| ISUZU | ELF 150(1t~1.5t)- KA,NHR,WHR | Drive Pinion | 8-94408-084-0 | 45*78*11/18 | MUSASHI | I3511 | '76~'86.8 |
| ISUZU | ELF 150(1t~1.5t)- KA,NHR,WHR | Front Wheel | 8-94248-116-1 | 63*80*7.7 | MUSASHI | I3605 | '84.6~ |
| ISUZU | ELF 150(1t~1.5t)- KA,NHR,WHR | Front Wheel | 9-00724-023-0 | 65*85*10 | MUSASHI | I3515 | '85.6~ |
| ISUZU | ELF 150(1t~1.5t)- KA,NHR,WHR | Rear Wheel Inner | 5-00625-092-0 | 39.5*60*10 | MUSASHI | I3588 | '75~'84.6 |
| ISUZU | ELF 150(1t~1.5t)- KA,NHR,WHR | Rear Wheel Inner | 9-09724-035-0 | 39.5*60*10 | MUSASHI | I3588 | '75~'84.6 |
| ISUZU | ELF 150(1t~1.5t)- KA,NHR,WHR | Rear Wheel Inner | 8-90336-314-0 | 77*102*9/19 | MUSASHI | I3585 | '77.9~'84.6 |
| ISUZU | ELF 150(1t~1.5t)- KA,NHR,WHR | Rear Wheel Inner | 8-90367-959-0 | 77*102*9/19 | MUSASHI | I3585 | '77.9~'84.6 |
| ISUZU | ELF 150(1t~1.5t)- KA,NHR,WHR | Rear Wheel Inner | 9-00924-241-0 | 77*93*10 | MUSASHI | I3537 | '75~'77.8 |

| CAR | MODEL | APPLICATION | OEM NO. | SIZE | DATA acc. | CODE | YEARS |
|-------|------------------------------------|-----------------------|----------------|----------------|-----------|--------|-----------|
| ISUZU | ELF 150(1t~1.5t)-KA,NHR,WHR | Rear Wheel Outer | 9-00924-242-0 | 46*94.4*8 | MUSASHI | I3538 | '75~'84.5 |
| ISUZU | ELF 150(1t~1.5t)-KA,NHR,WHR | Rear Wheel Outer | 9-09724-022-0 | 52*72*7.5 | MUSASHI | I3586 | '75~'84.6 |
| ISUZU | ELF 150(1t~1.5t)-KA,NHR,WHR | Steering Sector Shaft | 9-09924-451-0 | 30*42*8 | MUSASHI | I3563 | '75~'85.5 |
| ISUZU | ELF 150(1t~1.5t)-KA,NHR,WHR | Transmission Rear | 8-94223-026-0 | 35*49.2*12.5 | MUSASHI | I3901 | '75~'84.5 |
| ISUZU | ELF 150(1t~1.5t)-KA,NHR,WHR | Transmission Rear | 9-09724-032-0 | 40*68*11 | MUSASHI | I3584 | '75~'84.6 |
| ISUZU | ELF 150(1t~1.5t)-KA,NHR,WHR | Transmission Rear | 5-09625-017-0 | 40*68*11 | MUSASHI | I3584 | '75~'84.6 |
| ISUZU | ELF 250 NKR ALL | Front wheel | 894248-1170/71 | 73*90*8 | PAYEN | NJ 737 | |
| ISUZU | ELF 250 TL ALL | Front wheel | 909724-0230/31 | 65*85*10 | PAYEN | NJ 394 | |
| ISUZU | ELF 250 TL TL...except 44.54.64 | Differential pinion | 909724-0050/60 | 45*78*12/25.5 | PAYEN | NJ 570 | |
| ISUZU | ELF 250 WKR ALL | Transmission rear | 509625-0170 | 40*68*11 | PAYEN | NJ 423 | |
| ISUZU | ELF 350.450(3t~4t)-KS,NPR | Crank Shaft Front | 5-09625-054-0 | 60*82*12 | MUSASHI | I3545 | '71~ |
| ISUZU | ELF 350.450(3t~4t)-KS,NPR | Crank Shaft Front | 8-94373-765-0 | 60*82*12 | MUSASHI | I3545 | '71~ |
| ISUZU | ELF 350.450(3t~4t)-KS,NPR | Crank Shaft Rear | 8-94107-568-0 | 100*135*10 | MUSASHI | I3613 | '84.6~ |
| ISUZU | ELF 350.450(3t~4t)-KS,NPR | Crank Shaft Rear | 5-09625-014-1 | 100*135*15 | MUSASHI | I3560 | '71~'84.5 |
| ISUZU | ELF 350.450(3t~4t)-KS,NPR | Crank Shaft Rear | 5-09625-052-0 | 100*135*15 | MUSASHI | I3560 | '71~'84.5 |
| ISUZU | ELF 350.450(3t~4t)-KS,NPR | Drive Pinion | 9-09724-005-0 | 45*78*11/18 | MUSASHI | I3511 | '84.6~ |
| ISUZU | ELF 350.450(3t~4t)-KS,NPR | Drive Pinion | 9-09724-006-0 | 45*78*11/18 | MUSASHI | I3511 | '84.6~ |
| ISUZU | ELF 350.450(3t~4t)-KS,NPR | Drive Pinion | 8-94408-085-0 | 45*78*11/18 | MUSASHI | I3511 | '84.6~ |
| ISUZU | ELF 350.450(3t~4t)-KS,NPR | Drive Pinion | 8-94408-064-0 | 45*78*11/18 | MUSASHI | I3511 | '84.6~ |
| ISUZU | ELF 350.450(3t~4t)-KS,NPR | Drive Pinion | 8-94408-083-0 | 58*103*12/19.5 | MUSASHI | I3593 | '71~'84.6 |
| ISUZU | ELF 350.450(3t~4t)-KS,NPR | Drive Pinion | 9-09724-010-0 | 58*103*12/19.5 | MUSASHI | I3593 | '71~'84.6 |
| ISUZU | ELF 350.450(3t~4t)-KS,NPR | Drive Pinion | 9-09724-011-0 | 58*103*12/19.5 | MUSASHI | I3593 | '71~'84.6 |
| ISUZU | ELF 350.450(3t~4t)-KS,NPR | Fear Wheel Inner | 8-94336-316-0 | 80*113*12/20 | MUSASHI | I3513 | '71~'84.6 |
| ISUZU | ELF 350.450(3t~4t)-KS,NPR | Fear Wheel Inner | 8-94367-958-0 | 80*113*12/22 | MUSASHI | I3513 | '71~'84.6 |
| ISUZU | ELF 350.450(3t~4t)-KS,NPR | Fear Wheel Inner | 9-09724-018-0 | 80*113*12/22 | MUSASHI | I3513 | '71~'84.6 |
| ISUZU | ELF 350.450(3t~4t)-KS,NPR | Fear Wheel Inner | 8-94336-316-0 | 80*113*12/22 | MUSASHI | I3513 | '71~'84.6 |
| ISUZU | ELF 350.450(3t~4t)-KS,NPR | Front Wheel | 9-09724-023-0 | 65*85*10 | MUSASHI | I3515 | '71~'80.1 |
| ISUZU | ELF 350.450(3t~4t)-KS,NPR | Front Wheel | 8-94248-117-1 | 73*90*8 | MUSASHI | I3606 | '84.6~ |
| ISUZU | ELF 350.450(3t~4t)-KS,NPR | Rear Wheel Outer | 9-09724-019-0 | 49*100*8 | MUSASHI | I3514 | '71~'84.5 |
| ISUZU | ELF(1.5t)-NHS(4WD)...Disc Brake | Wheel Hub Front | 8-97211-082-0 | 65*93*8.5/18 | MUSASHI | I3639 | '91.7~ |
| ISUZU | ELF(2t) | Engine Injection Pump | | 20*31*7 | MUSASHI | I3646 | '84.6~ |

| CAR | MODEL | APPLICATION | OEM NO. | SIZE | DATA acc. | CODE | YEARS |
|-------|--|------------------------------|---------------------|----------------|-----------|--------|--------------|
| ISUZU | ELF(2t)- NKR,WKR...4JG2 | Engine Crank Shaft Front | 09283-50001 | 50*68*7/9 | MUSASHI | ※ | '93.4~ |
| ISUZU | ELF(2t)-NKS | Transmisssion Front Cover | | 34*48*8 | MUSASHI | I3650 | '90.5~ |
| ISUZU | ELF,Forward | Crank Shaft | 9-09924-433-0 | 100*135*15 | MUSASHI | | |
| ISUZU | Fargo -WFR,WFS | Crank Shaft Front | 8-84214-912-0 | 40*56*7 | MUSASHI | I3615 | '81.1~'88.11 |
| ISUZU | Fargo -WFR,WFS | Front Wheel | 8-94224-173-0 | 48*62/70*7/10 | MUSASHI | I3602 | '81.1~'82.4 |
| ISUZU | Fargo -WFR,WFS | Front Wheel | 8-94169-621-0 | 50*70*7/9.5 | MUSASHI | I3603 | '82~'82.5 |
| ISUZU | Fargo -WFR,WFS | Front Wheel | 5-42316-010-0 | 50*70*7/9.5 | MUSASHI | I3603 | '82~'82.5 |
| ISUZU | Fargo -WFR,WFS | Rear Wheel Outer | 9-09724-054-0 | 48*70*9.5 | MUSASHI | I3599 | '81.1~'88.10 |
| ISUZU | FCR.FDR | Differential Pinion | 1-09625-048-0 | 60*103*12/20 | MUSASHI | I3507 | '77~'84 |
| ISUZU | FCR.FDR | Front Wheel | 109625-0060 | 75*112*10/17.5 | PAYEN | NJ465 | 77-84 |
| ISUZU | FCR.FDR | Transmission | 109625-1730 | 60*77*12 | PAYEN | NJ477 | 76-84 |
| ISUZU | Forward 6BB1 6 CYL Diesel 5393 cc | Timing Cover | 509625-0150/540 | 60*82*12 | PAYEN | NJ 231 | |
| ISUZU | Forward 6BG1 6 CYL Diesel 6494 cc | | 109625-1120/1950 | 105*135*14 | PAYEN | NJ 596 | |
| ISUZU | Forward F FRD.FRR.FSD.FSR .FTR.MLD | | 109625-3570/9404411 | 40*56*6.5 | PAYEN | NJ 789 | |
| ISUZU | Forward (6t~7t)- FTR...6BD1,6BG1 | Engine Crank Shaft Front | | 60*82*12 | MUSASHI | I3664 | '87.11~'94 |
| ISUZU | Forward (6t~7t)- JBR,JCR,JDR,FTR | Engine Crank Shaft Front | | 104*137*13 | MUSASHI | | '90.4~ |
| ISUZU | Forward ,Isuzu Truck,Bus | Drive Pinion | 1-09625-017-0 | 68*124*11.5/27 | MUSASHI | I3504 | '81~'84.2 |
| ISUZU | Forward - TY,TR,SBR,SCR,S DR,FCR,FDR,JCR,J BR,JDR,FSR,FSD,F FR,FRD,NRR,FTR, SCS,FRS,FSS | Front Wheel | 9-09625-006-0 | 75*112*10/17.5 | MUSASHI | I3573 | '76~'84.2 |
| ISUZU | Forward - TY,TR,SBR,SCR,S DR,FCR,FDR,JCR,J BR,JDR,FSR,FSD,F FR,FRD,NRR,FTR, SCS,FRS,FSS | Rear Wheel Inner | 1-09625-043-0 | 95*132*12/21.5 | MUSASHI | I3575 | '76~'84.2 |
| ISUZU | Forward - TY,TR,SBR,SCR,S DR,FCR,FDR,JCR,J BR,JDR,FSR,FSD,F FR,FRD,NRR,FTR, SCS,FRS,FSS | Rear Wheel Outer | 1-09625-044-0 | 56*122*10.5 | MUSASHI | I3594 | '76~'84.2 |
| ISUZU | Forward - TY,TR,SBR,SCR,S DR,FCR,FDR,JCR,J BR,JDR,FSR,FSD,F FR,FRD,NRR,FTR, SCS,FRS,FSS | Rear Wheel Outer | 1-09625-331-0 | 56*122*10.5 | MUSASHI | I3594 | '76~'84.2 |
| ISUZU | Forward - TY,TR,SBR,SCR,S DR,FCR,FDR,JCR,J BR,JDR,FSR,FSD,F FR,FRD,NRR,FTR, SCS,FRS,FSS | Rear Wheel Outer | 9-09924-499-0 | 64*132.5*13 | MUSASHI | I3565 | '76~'84.6 |

| CAR | MODEL | APPLICATION | OEM NO. | SIZE | DATA acc. | CODE | YEARS |
|-------|--|-----------------------|---------------------|----------------|-----------|--------|-----------|
| ISUZU | Forward - TY,TR,SBR,SCR,S DR,FCR,FDR,JCR,J BR,JDR,FSR,FSD,F FR,FRD,NRR,FTR, SCS,FRS,FSS | Rear Wheel Outer | 9-09924-470-0 | 64*132.5*13 | MUSASHI | I3565 | '76~'84.6 |
| ISUZU | Forward - TY,TR,SBR,SCR,S DR,FCR,FDR,JCR,J BR,JDR,FSR,FSD,F FR,FRD,NRR,FTR, SCS,FRS,FSS | Rear Wheel Outer | 9-09924-468-0 | 64*132.5*13 | MUSASHI | I3565 | '76~'84.6 |
| ISUZU | Forward - TY,TR,SBR,SCR,S DR,FCR,FDR,JCR,J BR,JDR,FSR,FSD,F FR,FRD,NRR,FTR, SCS,FRS,FSS | Transmission Front | 1-09625-498-0 | 40*56*6.5 | MUSASHI | | '84.2~ |
| ISUZU | Forward - TY,TR,SBR,SCR,S DR,FCR,FDR,JCR,J BR,JDR,FSR,FSD,F FR,FRD,NRR,FTR, SCS,FRS,FSS | Transmission Front | 1-09625-357-0 | 40*56*6.5 | MUSASHI | | '84.2~ |
| ISUZU | FOWARD | Steering Sector | 9-09924-516-0 | 38*52*9 | MUSASHI | I3568 | |
| ISUZU | FOWARD | Steering Worm | 9-09924-360-0 | 20*35*8 | MUSASHI | | |
| ISUZU | FOWARD | Timing Cover | 9-09924-0 | 60*82*12 | MUSASHI | | |
| ISUZU | FOWARD | Timing Cover | 9-09924-324-0 | 60*82*12 | MUSASHI | | |
| ISUZU | FOWARD | Transmission | 9-09924-551-0 | 60*77*12 | MUSASHI | | |
| ISUZU | FOWARD | Transmission | 9-09924-404-0 | 60*77*12 | MUSASHI | I3544 | '82.5~'84 |
| ISUZU | FOWARD | Transmission | 1-09625-052-0 | 65*92*13 | MUSASHI | I3509 | |
| ISUZU | FRD.FRR.FSD.FSR (14.5 inch) | Differential Pinion | 109625-2060 | 60*103*12/20 | PAYEN | NJ469 | 2/84-on |
| ISUZU | FRD.FRR.FSD.FSR (14.5 inch) | Differential Pinion | 109625-2061 | 60*103*12/20 | PAYEN | NJ469 | 2/84-on |
| ISUZU | FRD.FRR.FSD.FSR (14.5 inch) | Differential Pinion | 109625-2050 | 60*103*12/20 | PAYEN | NJ469 | 2/84-on |
| ISUZU | FRD.FRR.FSD.FSR (15.5 inch) | Differential Pinion | 94025809 | 68*124*11.5/27 | PAYEN | NJ466 | 2/84-on |
| ISUZU | FRD.FRR.FSD.FSR (15.5 inch) | Differential Pinion | 109625-0170 | 68*124*11.5/27 | PAYEN | NJ466 | 2/84-on |
| ISUZU | FRD.FRR.FSD.FSR (15.5 inch) | Differential Pinion | 94025809 | 68*124*11.5/27 | PAYEN | NJ466 | 2/84-on |
| ISUZU | FRD.FRR.FSD.FSR .FTR MLD | Transmission Front | 94044119 | 40*56*6.5 | PAYEN | NJ789 | 2/84-on |
| ISUZU | G161Z 4 cyl (ohc) 1584 cc | Crank Shaft Rear | 94022595 | 82*105*13 | PAYEN | NJ060 | 73-75 |
| ISUZU | Gemini (R.W.D.)- PF50,60 | Drive Pinion | 8-11065-079-0 | 52*72*10 | MUSASHI | I3902 | '75~'87 |
| ISUZU | Gemini (R.W.D.)- PF50,60 | Front Wheel | 8-94216-107-0 | 38*52*6/14 | MUSASHI | I3900 | '75~'87 |
| ISUZU | Gemini 4FB1 4 CYL diesel 1817 cc | Crank Shaft Rear | 894214-930/9421491 | 95*118*10 | PAYEN | NJ322 | |
| ISUZU | Gemini G161Z 4 CYL (OHC) 1584 cc | Crank Shaft Rear | 909924-4490/9402259 | 82*105*13 | PAYEN | NJ 060 | |
| ISUZU | Gemini | Front wheel inner | 894108-6630/941086 | 50*64*6.5 | PAYEN | NJ 665 | |
| ISUZU | Gemini | Rear wheel | 894144-6140/941446 | 38*52*7/12 | PAYEN | NK 006 | |
| ISUZU | Gemini PF PF50.60 | Differential pinion | 811065-0790 | 52*72*10 | PAYEN | NJ 597 | |
| ISUZU | Gemini PF PF50.60 | Front Wheel | 894216-1070/942161 | 38*52*6/14 | PAYEN | NJ 679 | |
| ISUZU | Gemini PF PF50.60 | Transmission rear | 894223-0260 | 35*49.2*12.5 | PAYEN | NJ 453 | |

| CAR | MODEL | APPLICATION | OEM NO. | SIZE | DATA acc. | CODE | YEARS |
|-------|--|--------------------|----------------|----------------|-----------|--------|-------------|
| ISUZU | Gemini(RWD)-PF60...4FB1 | Engine Oil Pump | | 28*40*8 | MUSASHI | I3673 | '79.11~'87 |
| ISUZU | GRMINI (F.W.D.)- | Cam Shaft | 8-94482-157-0 | 40*52*6 | MUSASHI | | '86.4~ |
| ISUZU | GRMINI (F.W.D.)- | Cam Shaft | 8-94251-171-0 | 40*52*6 | MUSASHI | | '85.3~'86.3 |
| ISUZU | GRMINI (F.W.D.)- | Crank Shaft Front | 8-94468-654-0 | 40*52*6 | MUSASHI | | '85.~ |
| ISUZU | GRMINI (F.W.D.)- | Front Wheel Outer | 8-94137-233-0 | 42*64*6 | MUSASHI | I3907 | '85.3~'90 |
| ISUZU | GRMINI (F.W.D.)- | Front Wheel Outer | 8-94464-555-0 | 50*60*6 | MUSASHI | | '90.2~ |
| ISUZU | GRMINI (F.W.D.)- | Rear Wheel | 8-94144-614-0 | 38*52*7/12 | MUSASHI | I3908 | '85.3~'90 |
| ISUZU | IMPULSE 4XE1 CYL (OHC) 1588 cc | Timing Cover | 894105-9730/31 | 40*52*6 | PAYEN | NJ 449 | |
| ISUZU | Isuzu Bus | Final Drive Pinion | 1-09625-017-0 | 68*124*11.5/27 | MUSASHI | I3504 | '81~'84.2 |
| ISUZU | Isuzu Bus Journey- BL(Journey M).BE(Journey L)CCM.LR(Journey K).DBR.MR(Journey Q) | Drive Pinion | 8-94406-065-0 | 45*78*11/18 | MUSASHI | I3511 | '72~ |
| ISUZU | Isuzu Bus Journey- BL(Journey M).BE(Journey L)CCM.LR(Journey K).DBR.MR(Journey Q) | Drive Pinion | 1-09625-045-0 | 60*103*12/20 | MUSASHI | I3507 | '76~'84 |
| ISUZU | Isuzu Bus Journey- BL(Journey M).BE(Journey L)CCM.LR(Journey K).DBR.MR(Journey Q) | Drive Pinion | 1-09625-206-1 | 60*103*12/20 | MUSASHI | I3507 | '76~'84 |
| ISUZU | Isuzu Bus Journey- BL(Journey M).BE(Journey L)CCM.LR(Journey K).DBR.MR(Journey Q) | Drive Pinion | 8-09747-609-0 | 60*103*12/20 | MUSASHI | I3507 | '76~'84 |
| ISUZU | Isuzu Bus Journey- BL(Journey M).BE(Journey L)CCM.LR(Journey K).DBR.MR(Journey Q) | Drive Pinion | 1-09625-205-0 | 60*103*12/20 | MUSASHI | I3507 | '76~'87.1 |
| ISUZU | Isuzu Bus Journey- BL(Journey M).BE(Journey L)CCM.LR(Journey K).DBR.MR(Journey Q) | Front Wheel | 1-09625-006-0 | 75*112*10/17.5 | MUSASHI | I3573 | '77~'84 |
| ISUZU | Isuzu Bus Journey- BL(Journey M).BE(Journey L)CCM.LR(Journey K).DBR.MR(Journey Q) | Rear Wheel Inner | 9-09924-241-0 | 77*93*10 | MUSASHI | I3537 | '72~'77.8 |
| ISUZU | Isuzu Bus Journey- BL(Journey M).BE(Journey L)CCM.LR(Journey K).DBR.MR(Journey Q) | Rear Wheel Outer | 9-09924-242-0 | 46*94.4*8 | MUSASHI | I3538 | '72~ |

| CAR | MODEL | APPLICATION | OEM NO. | SIZE | DATA acc. | CODE | YEARS |
|-------|--|----------------------------|---------------|---------------|-----------|-------|--------------|
| ISUZU | Isuzu Bus Journey-BL(Journey M).BE(Journey L)CCM.LR(Journey K).DBR.MR(Journey Q) | Transmission Rear | 9-09924-501-0 | 60*77*12 | MUSASHI | I3544 | '70~'90.4 |
| ISUZU | Isuzu Bus-LT | Transmission Front Cover | | 40*55*7 | MUSASHI | ※ | '93.7~ |
| ISUZU | Isuzu Pick up.CHEV.LUV-KB,TFR,TFS | Final Drive Pinion (Front) | | 35*65*13 | MUSASHI | I3604 | '79~'89.9 |
| ISUZU | Isuzu PICKUP.CHEV.LUV-KB,TFR,TFS | Crank Shaft Rear | 5-09625-036-0 | 82*105*13 | MUSASHI | I3562 | '76~'84.5 |
| ISUZU | Isuzu PICKUP.CHEV.LUV-KB,TFR,TFS | Front Knuckle | 8-94200-603-0 | 48*64*14 | MUSASHI | I3623 | '81.3~'88 |
| ISUZU | Isuzu PICKUP.CHEV.LUV-KB,TFR,TFS | Front Wheel | 9-09924-149-0 | 48*62/70*7/10 | MUSASHI | I3602 | '76~'88 |
| ISUZU | Isuzu PICKUP.CHEV.LUV-KB,TFR,TFS | Front Wheel | 8-94433-718-0 | 50*67*9 | MUSASHI | I3638 | '88.5~ |
| ISUZU | Isuzu PICKUP.CHEV.LUV-KB,TFR,TFS | Front Wheel | 8-94433-718-0 | 50*67*9 | MUSASHI | I3638 | '88.5~ |
| ISUZU | Isuzu PICKUP.CHEV.LUV-KB,TFR,TFS | Front Wheel | 8-94407-711-0 | 59*75*10 | MUSASHI | I3632 | '88.5~ |
| ISUZU | Isuzu PICKUP.CHEV.LUV-KB,TFR,TFS Isuzu PICKUP.CHEV.LUV-KB,TFR,TFS | Crank Shaft Front | 5-09625-083-0 | 65*84*9 | MUSASHI | | '81.9~'88.8 |
| ISUZU | Isuzu Truck (2-2XD)-SSG...Single Speed Diff. | Final Drive Pinion | 1-09625-030-0 | 80*143*10/37 | MUSASHI | I3505 | '80.1~'89.10 |
| ISUZU | Isuzu Truck 6t~8t-TXD,TD,TP,TDJ,SLR,SMR,SJR,CVR | Front Wheel | 1-09625-041-0 | 120*140*10.5 | MUSASHI | I3574 | '73~'83.9 |
| ISUZU | Isuzu Truck 6t~8t-TXD,TD,TP,TDJ,SLR,SMR,SJR,CVR | Rear Wheel Inner | 9-09924-415-0 | 100*145*15/26 | MUSASHI | I3542 | '71~'84 |
| ISUZU | Isuzu Truck 6t~8t-TXD,TD,TP,TDJ,SLR,SMR,SJR,CVR | Rear Wheel Inner | 9-09924-416-0 | 100*145*15/26 | MUSASHI | I3542 | '71~'84 |
| ISUZU | Isuzu Truck 6t~8t-TXD,TD,TP,TDJ,SLR,SMR,SJR,CVR | Rear Wheel Inner | 9-09924-417-0 | 100*145*15/26 | MUSASHI | I3542 | '71~'84 |
| ISUZU | Isuzu Truck 6t~8t-TXD,TD,TP,TDJ,SLR,SMR,SJR,CVR | Rear Wheel Outer | 1-09625-444-0 | 78*163*16 | MUSASHI | I3591 | '80.1~'83.9 |
| ISUZU | Isuzu Truck 6t~8t-TXD,TD,TP,TDJ,SLR,SMR,SJR,CVR | Rear Wheel Outer | 1-09625-226-0 | 78*163*16 | MUSASHI | I3591 | '80.1~'83.9 |
| ISUZU | Isuzu Truck 6t~8t-TXD,TD,TP,TDJ,SLR,SMR,SJR,CVR | Transmission Front | 9-09924-561-0 | 40*55*9 | MUSASHI | I3570 | '73~'84 |
| ISUZU | Isuzu Truck 6t~8t-TXD,TD,TP,TDJ,SLR,SMR,SJR,CVR | Transmission Front | 1-09625-181-0 | 48*62*9 | MUSASHI | I3601 | '80.1~'89.10 |

| CAR | MODEL | APPLICATION | OEM NO. | SIZE | DATA acc. | CODE | YEARS |
|-------|---|---------------------------|---------------------|--------------|-----------|--------|--------------|
| ISUZU | Isuzu Truck 6t~8t-TXD,TD,TP,TDJ,SLR,SMR,SJR,CVR | Transmission Front | 1-09625-235-0 | 48*62*9 | MUSASHI | I3601 | '80.1~'89.10 |
| ISUZU | Isuzu Truck 6t~8t-TXD,TD,TP,TDJ,SLR,SMR,SJR,CVR | Transmission Front | 1-09625-497-0 | 48*62*9 | MUSASHI | I3601 | '80.1~'89.10 |
| ISUZU | Isuzu Truck 6t~8t-TXD,TD,TP,TDJ,SLR,SMR,SJR,CVR | Transmission Rear | 1-09625-173-0 | 60*77*12 | MUSASHI | I3544 | '70~'90.4 |
| ISUZU | Isuzu Truck 6t~8t-TXD,TD,TP,TDJ,SLR,SMR,SJR,CVR | Transmission Rear | 9-09924-322-0 | 60*77*12 | MUSASHI | I3544 | '70~'90.4 |
| ISUZU | Isuzu Truck(10t~12t)-Drive System 2-2XD SPG,SRG,SSG,SM | Transmission Rear | 1-09625-359-0 | 80*100*12 | MUSASHI | I3627 | '83.8~ |
| ISUZU | Isuzu Truck(10t~12t)-Drive System 2-2XD SPG,SRG,SSG,SM | Transmission Rear | 1-09625-472-0 | 80*100*12 | MUSASHI | I3627 | '83.8~ |
| ISUZU | Isuzu Truck(10t~12t)-Drive System 2XD-D SPZ,TMK-X,SRZ,SSZ,SQZ,T | Front Wheel | 1-09625-941-0 | 120*140*10.5 | MUSASHI | I3574 | '73~'83.8 |
| ISUZU | Journey M BL...left handle | | 509625-0290 | 70*90*10 | PAYEN | NJ 424 | |
| ISUZU | JR nink sus | Rear Wheel | 94450127 | 45*62*9 | PAYEN | NK007 | 5/88-on |
| ISUZU | JR nink sus | Rear Wheel | 894450-1270 | 45*62*9 | PAYEN | NK007 | 5/88-on |
| ISUZU | JR nink sus | Rear Wheel | 94450127 | 45*62*9 | PAYEN | NK007 | 5/88-on |
| ISUZU | JR nink sus | Rear Wheel | 894450-1270 | 45*62*9 | PAYEN | NK007 | 5/88-on |
| ISUZU | JROURNEY Q DBR | Transmission | 909924-3220/4040 | 60*77*12 | PAYEN | NJ 477 | |
| ISUZU | JT150.190.600 | Rear Wheel | 94144614 | 38*52*7/12 | PAYEN | NK006 | 3/85-90 |
| ISUZU | JT150.190.600 | Rear Wheel | 8941446140 | 38*52*7/12 | PAYEN | NK006 | 3/85-90 |
| ISUZU | JT150.600 w/0 | Front Wheel | 894137-2330 | 42*64*6 | PAYEN | NJ666 | 3/85-90 |
| ISUZU | KA(MSG) flat low | Transmission | 909924-5610 | 40*55*9 | PAYEN | NJ471 | 77-5/84 |
| ISUZU | KA(MSG) flat low | Transmission | 109625-1550 | 40*55*9 | PAYEN | NJ471 | 77-5/84 |
| ISUZU | KB4#,5# 4WD | Differential pinion front | 94027655 | 35*65*13 | PAYEN | NJ676 | 79-88 |
| ISUZU | KB4#,5# 4WD | Front Wheel | 94227048 | 54*70*7/9.5 | PAYEN | NJ625 | 82-88 |
| ISUZU | MBG | Transmission | 909924-5510 | 60*77*12 | PAYEN | NJ477 | 2/84-on |
| ISUZU | PF50.60 | Front Wheel | 94216107 | 38*52*6/14 | PAYEN | NJ679 | 75-on |
| ISUZU | PF50.60 | Front Wheel | 894216-1070 | 38*52*6/14 | PAYEN | NJ679 | 75-on |
| ISUZU | Piazza 4ZC1 4 CYL (OHC) 1994 cc | Cam Shaft | 894215-2200/9451522 | 30*45*8 | PAYEN | NJ 454 | |
| ISUZU | Piazza JR...nink sus | Rear wheel | 894146-2050 | 45*62*9 | PAYEN | NK 007 | |
| ISUZU | Piazza JR...nink sus | Rear wheel | 894146-2050 | 45*62*9 | PAYEN | NK 007 | |
| ISUZU | Piazza-JR | Crank Shaft Rear | 8-94111-750-0 | 82*105*13 | MUSASHI | I3562 | '81.5~'88.4 |
| ISUZU | Pick up 4ZD1 4 CYL (OHC) 2254 cc | Cam Shaft | 894215-2200/942152 | 30*45*8 | PAYEN | NJ 454 | |
| ISUZU | Pick up 4ZD1 4 CYL (OHC) 2544 cc | Timing Cover | 894214-9120/942149 | 40*56*7 | PAYEN | NJ 323 | |
| ISUZU | Pick up C223D 4 CYL Diesel 2238 cc | Crank Shaft Rear | 509625-0360/9402632 | 82*105*13 | PAYEN | NJ 265 | |
| ISUZU | Pick up KB KB4#,5#...4WD | Front wheel outer | 894227-0480/81 | 54*70*7/9.5 | PAYEN | NJ 625 | |
| ISUZU | Pick up TFR.TFS TFR...2WD | Front wheel | 894433-7180/944337 | 50*67*9 | PAYEN | NK 010 | |
| ISUZU | SLR | Front Wheel | 109625-0410 | 120*140*10.5 | PAYEN | NJ467 | 73-83 |
| ISUZU | SLR.MLE | Transmission | 909924-3380 | 68*90*12 | PAYEN | NJ500 | 73-83 |
| ISUZU | SLR.MLE | Transmission | 109625-0630 | 68*90*12 | PAYEN | NJ500 | 73-83 |

| CAR | MODEL | APPLICATION | OEM NO. | SIZE | DATA acc. | CODE | YEARS |
|-------|---------------------------------------|---------------------------|--------------------|----------------|-----------|--------|--------------|
| ISUZU | SLR MLE | Transmission | 94025810 | 68*90*12 | PAYEN | NJ500 | 73-83 |
| ISUZU | TFR 2WD | Front Wheel | 94433718 | 50*67*9 | PAYEN | NK010 | 5/88-on |
| ISUZU | TFS 4WD | Front Wheel | 94407711 | 59*75*10 | PAYEN | NK009 | 5/88-on |
| ISUZU | TFS 4WD | Front Wheel | 894407-7110 | 59*75*10 | PAYEN | NK009 | 5/88-on |
| ISUZU | Trooper UBS ALL | | 894407-7110/944077 | 59*75*10 | PAYEN | NK 009 | |
| ISUZU | Trooper.Big Horn | Engine Crank Shaft Front | | 65*84*9 | MUSASHI | I3644 | '81.9~'88 |
| ISUZU | Trooper.Big Horn- | Cam Shaft | 8-94334-845-0 | 30*45*7 | MUSASHI | | '88.9~ |
| ISUZU | Trooper.Big Horn- | Cam Shaft | 8-94327-062-0 | 30*45*7 | MUSASHI | | '88.9~ |
| ISUZU | Trooper.Big Horn- | Cam Shaft | 8-94215-220-0 | 30*45*8 | MUSASHI | | '86.11~'87.7 |
| ISUZU | Trooper.Big Horn- | Fear Wheel Inner | 8-94257-318-0 | 33*55*9.5 | MUSASHI | I3598 | '81.9~'87.10 |
| ISUZU | Trooper.Big Horn- | Fear Wheel Inner | 9-09724-063-0 | 33*55*9.5 | MUSASHI | I3598 | '81.9~'87.10 |
| ISUZU | Trooper.Big Horn- | Front Axle Knuckle | 8-94240-603-0 | 48*64*14 | MUSASHI | I3623 | '81.9~'86.10 |
| ISUZU | Trooper.Big Horn- | Rear Wheel Outer | 8-94441-817-1 | 48*70*13/18 | MUSASHI | I3637 | '87.8~'88.9 |
| ISUZU | Trooper.Big Horn- | Rear Wheel Outer | 9-09724-064-0 | 48*70*9.5 | MUSASHI | I3599 | '81.9~'87.7 |
| ISUZU | TRROPER UBS ALL | Differential pinion front | 509625-0020/21 | 35*65*13 | PAYEN | NJ 676 | |
| ISUZU | TRROPER UBS | | 8944418-8170/8171 | 48*70*13/18 | PAYEN | NJ 984 | |
| ISUZU | Truck & Bus 6BB1 6 CYL Diesel 5393 cc | Crank Shaft Rear | 509625-0140/41/520 | 100*135*15 | PAYEN | NJ 232 | |
| ISUZU | Truck C (6-8T) CVR...16.5 inch | Differential pinion | 109625-0170/940258 | 68*124*11.5/27 | PAYEN | NJ 466 | |
| ISUZU | Truck C (6-8T) CVR...16.5 inch | Differential pinion | 109625-0170/940258 | 68*124*11.5/27 | PAYEN | NJ 466 | |
| ISUZU | Truck T (6-8T) TXD | | 109625-0470/80 | 60*103*12/20 | PAYEN | NJ 469 | |
| ISUZU | Truck,Bus | Crank Shaft | 1-09625-051-0 | 120*153*15 | MUSASHI | | |
| ISUZU | Truck,Bus | Decomp Shaft | 1-09625-133-0 | 25*45*11 | MUSASHI | I3536 | |
| ISUZU | Truck,Bus | Decomp Shaft | 9-09924-209-0 | 25*45*11 | MUSASHI | | |
| ISUZU | Truck,Bus | Rear Wheel Inner | 9-09924-172-0 | 100*125*13 | MUSASHI | | |
| ISUZU | Truck,Bus | Steering Sector | 9-09924-563-0 | 45*60*9 | MUSASHI | | |
| ISUZU | Truck,Bus | Timing Cover | 9-09924-448-0 | 50*68*9 | MUSASHI | | |
| ISUZU | WFR ALL | Rear wheel outer | 909724-0640/940212 | 48*70*9.5 | PAYEN | NJ 100 | |
| ISUZU | | Cank Shaft Rear | 9-09924-356-0 | 105*135*14 | MUSASHI | I3552 | '76~'84 |
| ISUZU | | Cank Shaft Rear | 1-09625-195-0 | 105*135*14 | MUSASHI | I3552 | '76~'84 |
| ISUZU | | Cank Shaft Rear | 1-09625-396-0 | 128*148*14 | MUSASHI | | '86.4~ |
| ISUZU | | Cank Shaft Rear | 1-09625-441-0 | 128*148*14 | MUSASHI | | '86.4~ |
| ISUZU | | Crank Shaft Front | 8-94396-199-1 | 104*137*13 | MUSASHI | | '90.4~ |
| ISUZU | | Crank Shaft Front | 1-09625-200-0 | 120*153*15 | MUSASHI | I3620 | '78.4~'83 |
| ISUZU | | Crank Shaft Front | 1-09625-451-0 | 120*153*15 | MUSASHI | | '88.8~ |
| ISUZU | | Crank Shaft Front | 1-09625-438-0 | 60*82*12 | MUSASHI | | '87.11~ |
| ISUZU | | Crank Shaft Front | 9-09924-507-0 | 60*82*12 | MUSASHI | I3545 | '70~'84 |
| ISUZU | | Crank Shaft Front | 5-09625-015-0 | 60*82*12 | MUSASHI | I3545 | '70~'84 |
| ISUZU | | Crank Shaft Front | 1-09625-442-0 | 70*92*10/16 | MUSASHI | | '88.8~ |
| ISUZU | | Crank Shaft Front | 1-09625-128-0 | 70*92*12 | MUSASHI | I3546 | '71~'84 |
| ISUZU | | Crank Shaft Front | 9-09924-550-0 | 70*92*12 | MUSASHI | I3546 | '71~'84 |
| ISUZU | | Crank Shaft Front | 9-09924-327-0 | 70*92*12 | MUSASHI | I3546 | '71~'84 |
| ISUZU | | Crank Shaft Front | 9-09924-506-0 | 70*92*12 | MUSASHI | I3546 | '71~'84 |
| ISUZU | | Crank Shaft Rear | 1-09625-402-0 | 100*135*14 | MUSASHI | | '86.9~ |
| ISUZU | | Crank Shaft Rear | 1-09625-384-0 | 105*135*14 | MUSASHI | I3552 | '84.12~'86.3 |
| ISUZU | | Crank Shaft Rear | 9-09924-358-0 | 105*135*14 | MUSASHI | I3552 | '74.1~'79 |
| ISUZU | | Crank Shaft Rear | 9-09924-366-0 | 105*135*14 | MUSASHI | I3552 | '84.12~'86.3 |
| ISUZU | | Drive Pinion | 1-09625-047-0 | 60*103*12/20 | MUSASHI | I3507 | '76~'87.1 |
| ISUZU | | Drive Pinion | 1-09625-432-0 | 60*103*12/20 | MUSASHI | I3507 | '76~'87.1 |
| ISUZU | | Drive Pinion | 1-09625-484-0 | 60*103*12/20 | MUSASHI | I3507 | '76~'87.1 |
| ISUZU | | Drive Pinion | 1-09625-323-0 | 86*127*16/24 | MUSASHI | | '83.8~ |
| ISUZU | | Transmission | 9-09924-338-0 | 68*90*12 | MUSASHI | I3547 | '71~'83 |
| ISUZU | | Transmission | 1-09625-063-0 | 68*90*12 | MUSASHI | I3547 | '71~'83 |
| ISUZU | | | 94050718 | 100*135*14 | PAYEN | NK081 | |
| ISUZU | | | 109625-4020 | 100*135*14 | PAYEN | NK081 | |
| ISUZU | | | 894156-5890 | 14.8*32*7.5 | PAYEN | NK072 | |
| ISUZU | | | 115639-0120 | 17*28*6 | PAYEN | NJ792 | |

| CAR | MODEL | APPLICATION | OEM NO. | SIZE | DATA acc. | CODE | YEARS |
|--------|--|-----------------------------|--------------------|-----------------|-----------|--------|-------------|
| ISUZU | | | 981225-0710 | 20*30*6 | PAYEN | NJ805 | |
| ISUZU | | | 109625-3530 | 25*38*7 | PAYEN | NK080 | |
| ISUZU | | | 144139-0520 | 25*38*7 | PAYEN | NK080 | |
| ISUZU | | | 119158-0210 | 25*45*8 | PAYEN | NK071 | |
| ISUZU | | | 94053631 | 25*45*8 | PAYEN | NK071 | |
| ISUZU | | | 909924-4570 | 28.6*40*8 | PAYEN | NJ682 | |
| ISUZU | | | 94026061 | 28.6*40*8 | PAYEN | NJ682 | |
| ISUZU | | | 5-09625-062-1 | 38*49.21*9 | | | |
| ISUZU | | | 909924-5160 | 38*52*9 | PAYEN | NJ587 | |
| ISUZU | | | 109625-0520 | 65*92*12 | PAYEN | NJ584 | |
| ISUZKI | | | 119158-0180 | 25*45*8 | PAYEN | NK071 | |
| ISUZU | | | 92049-2076 | 15*25*6 | | | |
| ISUZU | ALL | Front Wheel | 8-94248-117-1 | 73*90*7.5 | PAYEN | NJ 737 | |
| ISUZU | FE311.315.317 dump | Front Wheel | MT009305 | 68*90*12 | PAYEN | NJ500 | 10/85-on |
| ISUZU | JBR.JCR.JDR | Transmission | 109625-4040 | 60*77*12 | PAYEN | NJ477 | 76-84 |
| ISUZU | JT150.190.600 | Front Wheel | 94108663 | 50*64*6.5 | PAYEN | NJ665 | 3/85-90 |
| ISUZU | TS125 | Front folk | 51153-48500 | 32*43*12.5 | | | |
| ISUZU | Isuzu Truck(10t~12t)- Drive System 2-2XD SPG,SRG,SSG,SM | Rear Wheel Outer | 1-09625-444-0 | 78*163*16 | MUSASHI | I3591 | '80.1~'83.8 |
| ISUZU | Isuzu Truck 6t~8t- TXD,TD,TP,TDJ,SL R,SMR,SJR,CVR | Rear Wheel Outer | 1-09625-226-0 | 78*163*16 | MUSASHI | I3591 | '80.1~'83.9 |
| ISUZU | Isuzu Truck (6t~8t)- CVR | Wheel Hub Rear Outer | | 78*163*16 | MUSASHI | I3591 | '83.9~ |
| ISUZU | 2XD Truck C (10- 12T) CXM.CXK.CXL | Rear wheel (front) outer | 109625-2260 | 78.5*105*163*16 | PAYEN | NJ 936 | |
| ISUZU | Truck S (6-8T) SMR361 | Rear wheel (front) outer | 909924-3920/940474 | 78.5*105*163*16 | PAYEN | NJ 936 | |
| ISUZU | Forward (4t~5t)- TY,TR,SBR,SCR,S DR,FCR,FDR,FRR, FRD,FSR,FSD,NRR ,SCS,FRS,FSS | Wheel Hub Front | | 75*112*10*17.5 | MUSASHI | I3573 | '76~'84.2 |
| ISUZU | Forward - TY,TR,SBR,SCR,S DR,FCR,FDR,JCR,J BR,JDR,FSR,FSD,F FR,FRD,NRR,FTR, SCS,FRS,FSS | Front Wheel | 9-09625-006-0 | 75*112*10*17.5 | MUSASHI | I3573 | '76~'84.2 |
| ISUZU | Isuzu Bus- CDM,ECM,EDM,LT, BA,BU,CRA,CSA,C Q,CH,CL,CJ,CP,LV | Front Wheel | 1-09625-006-0 | 75*112*10*17.5 | MUSASHI | I3573 | '82.5~'84 |
| ISUZU | FCR.FDR | Front Wheel | 109625-0060 | 75*112*10/17.5 | PAYEN | NJ465 | 77-84 |
| ISUZU | 2-2XD-D Truck S (10-12T) SMH.SSH | Front wheel rear | 109625-0060 | 75*112*10*17.5 | PAYEN | NJ 465 | |
| ISUZU | Bus C CDM | Front wheel | 109625-0060 | 75*112*10*17.5 | PAYEN | NJ 465 | |
| ISUZU | ELF(1.5t)- NHS(4WD)...Disc Brake | Wheel Hub Front | 8-97211-082-0 | 65*93*8.5/18 | MUSASHI | I3639 | '91.7~ |
| ISUZU | Fargo -WFR,WFS | Front Wheel | 5-42316-010-0 | 50*70*7/9.5 | MUSASHI | I3603 | '82~'82.5 |
| ISUZU | ISUZU FARGO WFR,WFS ◆4FC1,4 FD1,4FG1 | | 8-94227-475-0 | 20*31*7 | MUSASHI | I3646 | 85.12~96. |
| ISUZU | ELF(2t)- NKR,WKR...4JB1,4 JG2 | Engine Injection Pump | | 20*31*7 | MUSASHI | I3646 | '84.6~ |

| CAR | MODEL | APPLICATION | OEM NO. | SIZE | DATA acc. | CODE | YEARS |
|------------|--|---|--------------------|----------------|-----------|----------|-----------|
| ISUZU | Fargo - WFR,WFS...4FC,4F C,4FG | Engine Injection Pump | | 20*31*7 | MUSASHI | I3646 | '85.12~ |
| ISUZU | ISUZU ELF (1.5T) NHR,WHR,NHS 4 JA1,4JB1,4JG2 | Engine INJECTION PUMP | 8-94227-475-0 | 20*31*7 | MUSASHI | I3646 | 84.6~ |
| ISUZU | Trooper-Big Horn--UBS...4JB1,4JG2 | Engine Injection Pump | | 20*31*7 | MUSASHI | I3646 | '87.8~ |
| ISUZU | ISUZU TRUCK (2XD-D) CXZ,CYZ 4 REAR | | 9-09924-470-0 | 64*132.5*13 | MUSASHI | I3565 | 96.11~99. |
| ISUZU | Bus L LT...feel sus. | Rear wheel outer | 909924-4680/4700 | 64*132.5*13 | PAYEN | NJ 479 | |
| ISUZU | Pick up TFR.TFS TFR...2WD | Front wheel | 894433-7180/944337 | 50*67*9 | PAYEN | NK 010 | 5/88-on |
| ISUZU | Forward , LUV 1.6/2.3/Trooper | Steering Sector | 9-09924-261-0 | 34*48*8 | MUSASHI | | |
| ISUZU | Trooper 4ZE1 4 CYL (OHC) 2238 cc | Timing Cover | 509625-0280/0830 | 65*84*9 | PAYEN | NJ266 | 83-on |
| ISUZU | | | 109625-0520 | 65*92*12 | PAYEN | NJ584 | |
| ISUZU | ISUZU ELF (1.5T) NHR,WHR,NHS 4 JA1,4JB1,4JG2 | Engine INJECTION PUMP | 8-94227-475-0 | 20*31*7 | MUSASHI | I3646 | 84.6~ |
| ISUZU | Isuzu Truck 6t~8t-TXD,TD,TP,TDJ,SL R,SMR,SJR,CVR | Rear Wheel Inner | 9-09924-417-0 | 100*145*15/26 | MUSASHI | I3542 | '71~'84 |
| KIA | | | M50517335 | 40*53/72*12/30 | | | |
| ALFA ROMEO | 145 ; 146 1,7 16v 94 → | Gearbox / Gear Selection Shaft | 60612499 | 16*24*7 | CORTECO | 12015773 | |
| ALFA ROMEO | Alfa Sud 1,2 ; 1,3 ; 1,5 ; 1,7 | Front Axle / Wheel Hub | 60709430 | 55*70*8 | CORTECO | 12011182 | |
| ALFA ROMEO | Arna 1,2 ; 1,3 | Front Axle / Wheel Hub | 60501377 | 55*70*8 | CORTECO | 12010981 | |
| ALFA ROMEO | Arna 1,2 ; 1,3 | Gearbox / Gear Selection Shaft | 60502531 | 16*24*7 | CORTECO | 12015773 | |
| ALFA ROMEO | Giulia 1,3 ; 1,6 | Rear Axle / Wheel Hub 1°s. | 60751055 | 30*52*10 | CORTECO | 12010887 | |
| ALFA ROMEO | Giulietta 1,3 ; 1,6 ; 1,8 ; 2,0 ; 2,0 Turbo | Engine / AR / Front Crankshaft | 60507107 | 35*50*10 | CORTECO | 12010669 | |
| ALFA ROMEO | GTV 2,0 T.B.V6 12v 95→ | Engine / AR16202 / Camshaft | 60567604 | 32*47*10 | CORTECO | 12014699 | |
| ALFA ROMEO | GTV 2,5 V6 | Engine / Camshaft | 60507402 | 32*47*10 | CORTECO | 12014699 | |
| ALFA ROMEO | GTV 2,5 V6 | Gearbox / Gear Selection Shaft | 60521168 | 18*32*8 | CORTECO | 12011352 | |
| ALFA ROMEO | Spider 1,6 ; 2,0 90→ | Gearbox / Input Gearbox | 60516722 | 26*37*7 | CORTECO | 12011291 | |
| ALFA ROMEO | Spider 3000 V6 16v 95→ | Engine / AR16101 / Backstand | 60610985 | 32*47*10 | CORTECO | 12014699 | |
| AUDI | 80 AVANT QUATTRO 2,3 91→ | Gearbox / Output Differential | 016409399 B | 45*60*8 | CORTECO | 12017270 | |
| AUDI | QUATTRO 2,6 ; 2,8 91→ | Gearbox / Output Differential | 016409399B | 45*60*8 | CORTECO | 12017270 | |
| AUDI | 90 2,0 ; 2,2 84→ | Rear Axle / Wheel Hub | 621501641 | 40*52/58*7.5 | CORTECO | 12011153 | |
| LANCIA | Kappa coupe 3,0 V6 24v 96→ | Engine / 838B / Camshaft | 60812037 | 32*47*10 | CORTECO | 12014699 | |
| MERCEDE S | 510 | AUTOMATIC TRANSMISSION / 720.1 / Oil Pump | 109975047 | 43*58*7 | CORTECO | 1020045 | |

| CAR | MODEL | APPLICATION | OEM NO. | SIZE | DATA acc. | CODE | YEARS |
|--------------|--|---|------------|---------------|-----------|----------|-------|
| MERCEDE S | 0 309 B Bus | Engine / M 121 / Water Pupm | 6504022200 | 22*35*7 | CORTECO | 12010836 | |
| MERCEDE S | 200 76→80 W123 | Rear Axle / Inner Wheel Hub | 79973547 | 59*72*12/12.5 | CORTECO | 12012242 | |
| MERCEDE S | 230 S W111 | Front Axle / Wheel Hub | 39979346 | 40*62*10/12 | CORTECO | 1019288 | |
| MERCEDE S | 300 E 4Matic 7/89→ 7/93 W124 | AUTOMATIC TRANSMISSION / 722.3-5 / Input Gearbox | 109974747 | 43*58*7 | CORTECO | 1020045 | |
| MERCEDE S | 300 E 4Matic 7/89→ 7/93 W124 | Front Axle / Wheel Hub | 119975147 | 45*64*12 | CORTECO | 12012039 | |
| MERCEDE S | 300 E 9/89→10/92 W124 | Rear Axle / Axle Shaft | 209972047 | 37*78.3*8/12 | CORTECO | 1019475 | |
| MERCEDE S | 300 GE ; G 300 4WD 463.2 | Front Axle / Differential Bevelgear Outer Side | 169975347 | 40*70*8/15 | CORTECO | 12015262 | |
| MERCEDE S | 300 SE-SEL 85→ W126 | Front Axle / Wheel Hub | 119975547 | 50*70*13.5 | CORTECO | 12012696 | |
| MERCEDE S | 328 ; 911 | Front Axle / Wheel Hub | 9976347 | 75*95*13 | CORTECO | 12013987 | |
| MERCEDE S | 408 DG | Rear Axle / Wheel Hub | 9971446 | 75*100*13 | CORTECO | 12011411 | |
| MERCEDE S | E 250 TD 95→ W210 | Rear Axle / Differential Bevelgear | 1019477 | 37*61*10/14 | CORTECO | 1019477 | |
| MERCEDE S | O 405 GTZ Bus | Front Axle / 739.2 / Wheel Hub | 119973646 | 100*130*13 | CORTECO | 12000552 | |
| MERCEDE S | Sprinter 208 D ; 210-21 2D ; S308D ; 310-312D ; 408D ; 410-412D 4WD | Engine / OM 601- 602 / Rear Crankshaft | 119970647 | 93*114*13 | CORTECO | 12012249 | |
| MERCEDE S | Sprinter 214 ; 314 ; S314N ; 414 ; 4WD | Engine / M 111 / Front Crankshaft | 109973347 | 45*67*8 | CORTECO | 12012248 | |
| MERCEDE S | Sprinter 214 ; 314 ; S314N ; 414 ; 4WD | Engine / M 111 / Rear Crankshaft | 109979047 | 93*114*13 | CORTECO | 12012249 | |
| MERCEDE S | Vito V280 | Engine / M 104 / Camshaft | 189977947 | 30*40*7 | CORTECO | 12011131 | |
| OPEL | Kadett A/B/C 1,0 ; 1,1 ; 1,2 | Gearbox / Input Gearbox 1°s. | 714401 | 25*35*7 | CORTECO | 12011487 | |
| OPEL | Vectra 1,8 ; 2,0 9/88 → | Engine / OHC / Camshaft | 636838 | 35*48*7 | CORTECO | 20011244 | |
| PEUGEOT | 304 Diesel 1,6 80→ | Rear Axle / Wheel Hub | 372412 | 40*52*7 | CORTECO | 12010931 | |
| PEUGEOT | 305 GL ; GR ; SR ; GLS ; S ; 1,3 ; 1,5→ 83 | Front Axle / Inner Wheel Hub | 334522 | 54*81*10 | CORTECO | 12011180 | |
| PEUGEOT | 504 Benzina | Front Axle / Wheel Hub 2°s. | 372418 | 45*60*10 | CORTECO | 12010951 | |
| PEUGEOT | 505 Benzina 1,8 ; 2,0→82 | Rear Axle / Inner Wheel Hub 1° s. | 334517 | 54*72*10 | CORTECO | 12011179 | |
| PEUGEOT | Boxer 1,9 Diesel | Front Axle / Outer Wheel Hub | 334616 | 69*85*10 | CORTECO | 12012931 | |
| POLSKI | R19 Chamade 1,7 | Engine / F2N ; F3N / Auxiliary | 7700719273 | 30*40*7 | CORTECO | 12014403 | |
| POLSKI | R20 LS ; TS ; TX 2,0 ; 2,2 | Engine / 829 ; 851 / Auxiliary Shaft | 7700719273 | 30*40*7 | CORTECO | 12014403 | |
| RENAULT | Austin MONTEGO | Engine / Camshaft | ADU7358 | 40*52*7 | CORTECO | 12010931 | |

| CAR | MODEL | APPLICATION | OEM NO. | SIZE | DATA acc. | CODE | YEARS |
|----------------|---|--|---------------|--------------|-----------|----------|-------|
| RENAULT | Espace 2,0 16v 96 → | Gearbox / Output Differential | 7703087142 | 50*65*10 | CORTECO | 12017069 | |
| RENAULT | Express 1,6 Diesel 87→ | Engine / F8M / Auxiliary Shaft | 7703087189 | 30*40*7 | CORTECO | 12014403 | |
| RENAULT | Laguna 1,9 RT ; RTI ; RXE 96→ | Engine / N7Q / Rear Crankshaft | 7436842092 | 98*110*8.5 | CORTECO | 15510087 | |
| RENAULT | RENAULT 11 曲軸 | | 770-308-7087 | 36*54*7.5 | | | |
| RENAULT | Rover 216 1,6 | Engine / Front Crankshaft 1°s. | CAM5601 | 30*40*7 | CORTECO | 12010673 | |
| SAAB | Truck.Bus | Steering Sector | 6-045-8420-00 | 38*52*9 | MUSASHI | | |
| SAAB | | Differenter Left | 8067-27040 | 37*45*9 | | | |
| SEAT | Alhambra 1,9 DIESEL 3/96→ | Engine / 1Z / Front Crankshaft | 0618103085A | 32*47*10 | CORTECO | 12012709 | |
| SEAT | Furgonetta Terra 1,0 | Engine / Rear Crankshaft | 40000460 | 64*80*8 | CORTECO | 12011436 | |
| SEAT | Furgonetta Terra 1,0 | Engine / Rear Crankshaft | 40000460 | 64*80*8 | CORTECO | 12011436 | |
| SEAT | Inca 1,6 ; 1,9 DIESEL 11/95 → | Engine / 1F ; 1Y- AEY / Camshaft | 026103085E | 32*47*10 | CORTECO | 12012709 | |
| SEAT | Randa 1,7 Diesel L ; GL ; GLX 84 | Engine / FIAT / Auxiliary Shaft | 40000470 | 30*52*7 | CORTECO | 12011539 | |
| SKODA | 130 L | Engine / Front Crankshaft | 953042307 | 42*56*7 | CORTECO | 12010943 | |
| SKODA | Octavia 1,6 97→ | Engine / AEH / Camshaft | 026103085F | 32*47*10 | CORTECO | 1019928 | |
| BMW | M 535i mod.E12 4/80→ | Rear Axle / Inner Wheel Hub | 33413604181 | 42*62*7 | CORTECO | 1020381 | |
| CITROEN | GSA 1,3 | Front Axle / Inner Wheel Hub | ZC9612612U | 72*86*7 | CORTECO | 7011559 | |
| TALBOT | 1307 ; 1308 ; 1309 ; 1510 | Front Axle / Inner Wheel Hub | 17510800 | 54*72*10 | CORTECO | 12011179 | |
| VAUXHALL | Astra 1,6 81→ ; Astra 1,8 83→ | Engine / OHC / Camshaft | 636836 | 35*48*7 | CORTECO | 20011244 | |
| VOLKSWA GEN | Bora 1,9 Diesel 99 → | Engine / AGM ; ALK ; AHF / Camshaft | 068103085E | 32*47*10 | CORTECO | 12012709 | |
| VOLKSWA GEN | Corrado 1,8 88→93 | Rear Axle / Wheel Hub | 357501641B | 40*52/58*7.5 | CORTECO | 12011153 | |
| VOLKSWA GEN | Golf 1,8 GTI ; Cabrio 1,8 82→84 | Engine / Auxiliary Shaft | 056103085B | 32*47*10 | CORTECO | 12012709 | |
| VOLKSWA GEN | Golf 1,9 Diesel TD 1/92→ | Engine / 1Y ; AEY ; AAZ ; 1Z ; AFN / Auxiliary Shaft | 026103085F | 32*47*10 | CORTECO | 1019928 | |
| VOLKSWA GEN | Golf 1,9 Diesel TD 1/92→ | Engine / 1Y ; AEY ; AAZ ; 1Z ; AFN / Input Gearbox | 20311113 | 21.9*40*8 | CORTECO | 12017266 | |
| VOLKSWA GEN | Golf Variant 1,4 ; 1,6 ; 1,8 ; 2,0 92→ | Engine / ABO ; AAM ; ABS ; 1Y ; 2E / Front Crankshaft | 030103085A | 32*47*10 | CORTECO | 12012709 | |
| VOLKSWA GEN | Golf Variant Diesel ; TD 11/91→ | ; 1Y / Auxiliary Shaft | 068103085Q | 32*47*10 | CORTECO | 12012709 | |
| VOLKSWA GEN | Jetta 1,3 8/79→ | Rear Axle / Wheel Hub | 321501641 | 40*52/58*7.5 | CORTECO | 12011153 | |
| VOLKSWA GEN | Taro 1,8 ; 2,2 2WD ; 4WD 89→ | Engine / 2Y ; 4Y / Front Crankshaft | J9031142019 | 42*60*7 | CORTECO | 19015085 | |
| VOLKSWA GEN | Taro 2,4D 2WD ; 4WD 89→ | Front Axle / Wheel Hub Alternative | J9031162001 | 62*85*8/10 | CORTECO | 19015054 | |

| CAR | MODEL | APPLICATION | OEM NO. | SIZE | DATA acc. | CODE | YEARS |
|------------|-----------------------------------|--|-------------|------------|-----------|----------|-------|
| VOLKSWAGEN | Taro 2,4D 2WD ; 4WD 89→ | Front Axle / Wheel Hub Alternative | J9031166001 | 66*85*8/10 | CORTECO | 19019062 | |
| VOLKSWAGEN | Tipo 2 2,0 Vanagon-USA 8/79→ | Rear Axle / Wheel Hub | 211501317 | 48*72*7/9 | CORTECO | 12013894 | |
| VOLKSWAGEN | Transporter Syncro 2,4D ; 2,5 90→ | Gearbox / Left Output Differential | 016409399B | 45*60*8 | CORTECO | 12017270 | |
| VOLVO | 264 ; 265 79→ | Engine / B21F ; B32A / Rear Crankshaft | 430118 | 92*110*10 | CORTECO | 12013897 | |
| VOLVO | 264 ; 265 Diesel 79→ | Engine / D24 / Camshaft | 1257221 | 32*47*10 | CORTECO | 12012709 | |
| VOLVO | 740 GL/GLE 85→ | Engine / B19 ; B23A-E ; B200-230 / Rear | 1266604 | 92*110*10 | CORTECO | 12013897 | |
| VOLVO | 940 , 960 Turbo 2,0i ; 2,3i 16v | Engine / B200-230 / Rear Crankshaft | 3514312.2 | 92*110*10 | CORTECO | 12013897 | |
| VOLVO | S40 ; V40 1,8 ; 2,0 96→ | Engine / B6144S ; B4184S ; B4204S / Rear Crankshaft | 6842274 | 98*110*8.5 | CORTECO | 15510087 | |
| VOLVO | S40 ; V40 1,8 ; 2,0 96→ | Front Axle / Inner Wheel Hub | 30870411.3 | 54*82*8/11 | CORTECO | 12017298 | |
| IVECO | Gear Box /117/IVECO E-90 | output gearbox | 8833200 | 80*100*13 | CORTECO | 117 | |
| IVECO | Gear Box | output gearbox | 400002160 | 80*100*13 | CORTECO | 90 | |
| ZASTAVA | 600 D ; Z 750 ; Z 750/850 | Gearbox / Input Gearbox | 40001460 | 17*28*7 | CORTECO | 12011426 | |
| ZASTAVA | 600 D ; Z 750 ; Z 750/850 | Rear Axle / Wheel Hub | 40001740 | 38*52*10 | CORTECO | 12011499 | |
| ZUNDAPP | 3 UERSN | | 707150840 | 16*22*3 | | | |
| FIAT | 850 T ; 900 T ; 900E | Engine / Rear Crankshaft | 40000450 | 64*80*8 | CORTECO | 12011424 | |
| FIAT | 850 T ; 900 T ; 900E | Engine / Rear Crankshaft | 40000450 | 64*80*8 | CORTECO | 12011424 | |
| FIAT | Croma 2,5 I.E.V6 | Engine / 834G / Auxiliary Shaft | 60808083 | 32*47*10 | CORTECO | 12014699 | |
| FIAT | Ducato Diesel 2,0 TD 94→ | Front Axle / Outer Wheel Hub | 7657423 | 69*85*10 | CORTECO | 12012931 | |
| FIAT | Ducato R94 1930 DS-TD 10-14Q | Front Axle / Outer Wheel Hub | 12012931 | 69*85*10 | CORTECO | 12012931 | |
| FIAT | Marea 1,6 16v 96→ | Engine / 182A4-A6 / Auxiliary Shaft | 7794301 | 30*47*7 | CORTECO | 12015927 | |
| FIAT | Palio weekend Europa 1,6 97→ | Engine / 178B3 / Auxiliary Shaft | 40004960 | 30*47*7 | CORTECO | 12015927 | |
| FIAT | Panda 1000 4x4 Fire | Rear Axle / Axle Shaft | 5948044 | 26*47*7 | CORTECO | 12010867 | |
| FIAT | Strada 130 T.C. 85→ | Engine / Rear Crankshaft | 40004310 | 74*90*10 | CORTECO | 12001483 | |
| FIAT | Uno 70 IE 1,3 ; 1,4 ; 1,5 | Engine / Rear Crankshaft | 40004280 | 64*80*8 | CORTECO | 12001480 | |
| FIAT | Uno 70 IE 1,3 ; 1,4 ; 1,5 | Engine / Rear Crankshaft | 40004280 | 64*80*8 | CORTECO | 12001480 | |
| FORD | Escort Diesel 1,6 2/84→ | Rear Axle / Wheel Hub 1°s. | 1579665 | 40*55*8 | CORTECO | 12011157 | |
| FORD | Granada 1,6 ; 2,0 2/72→ | Front Axle / Wheel Hub | 1979665 | 40*55*8 | CORTECO | 12011157 | |
| FORD | Transit Diesel 2,4 1/78→86 | Engine / D24→ 3/84 ; D24TD 3/84 → / Injection Pump Drive Sha | 1549132 | 18*35*10 | CORTECO | 12010819 | |

| CAR | MODEL | APPLICATION | OEM NO. | SIZE | DATA acc. | CODE | YEARS |
|------------------------------|-----------------------------------|---------------------------------------|-------------------------|----------------------|-----------|----------|-------|
| FORD | Transit Diesel 2,4 1/78→86 | Rear Axle / Wheel Hub | 6048469 | 69.6*99.97*12.7/20.7 | CORTECO | 12012569 | |
| INNOCENT I | 990 Diesel | Engine / DAIHATSU / | 551010605 | 28*42*8 | CORTECO | 12011691 | |
| YAMAHA | DT100X | | 93101-17062 | 17*25*4 | | | |
| YAMAHA | DX100 | ENGINEENGINE SPROCKET | 93102-26042 | 26*38*5 | | | |
| YAMAHA | FR80 | | 93109-14005 | 14*24*6 | | | |
| YAMAHA | Minarelli | | 478-1508-40 | 17*28*5 | | | |
| YAMAHA | Minarelli | | 478-1508-40 | 20*30/34*5/6.1 | | | |
| YAMAHA | DT100X | | 5115308010, 13723-14501 | 30*40*10.5 | | | |
| YAMAHA | DT125E | | 2A623-14500 | 31*43*12.5 | | | |
| YAMAHA | Minarelli | | 478-1508-40 | 20*42/43*8/9 | | | |
| YAMAHA | | | 93101-10002 | 10*22*7 | | | |
| YAMAHA | YZ250(+97),WR200 (92)啓動軸 | | 93104-19082 | 20*30*5 | | | |
| YAMAHA | DX100 | | 93210-14104 | 8*18*5 | | | |
| YAMAHA | DT100X;YB125E | Front folk | 137-23145-01 | 30*40.5*10.5 | | | |
| KOMATSU | 6D125 | Crank Shaft Front | AE3963E | 92.07*120.65*12.7 | NOK | TONYCO | |
| KOMATSU | S6D105(for 6137- 9901) | Crank Shaft Rear | 6130-21-4231 | 105*135*18 | | | |
| PROPELLE R SHAFT | PROPELLER SHAFT | Propeller Shaft Support | 40002050 | 75*120*13 | CORTECO | 12011284 | |
| REAR | Rear Axle/388 | Differential | 40001040 | 62*100*12 | CORTECO | 388 | |
| FRONT AXLE | Front Axle | Outer Axle Shaft | 8576283 | 70*90*10 | CORTECO | 12011199 | |
| GEARBOX ES | Fuller RT 14609 | Gear Selection Shaft | 8193879 | 22*35*7 | CORTECO | 12002188 | |
| GEARBOX ES | ZF 16S-130 | Input Gearbox | 9981327 | 48*75*8 | CORTECO | 12011307 | |
| GEARBOX ES | ZF 16S-151 | Input Gearbox | 7982064 | 55*75*8 | CORTECO | 12011308 | |
| GEARBOX ES | ZF 4S-120 GP | Input Gearbox Inner Side (Altern.) | 42487132 | 60*85*12 | CORTECO | 12012578 | |
| GEARBOX ES | GEARBOX/131/ZF | input Gearbox outer side | 42493153 | 70*90*10 | CORTECO | 131 | |
| Engine | 8010 | Rear Crankshaft | 99457401 | 114*135*13 | CORTECO | 12014858 | |
| Engine | 8060.02 | Rear Crankshaft 1°s. | 40000720 | 95*120*13 | CORTECO | 12011314 | |
| Engine | 8060.04 | Rear Crankshaft | 40002810 | 110*135*13 | CORTECO | 12011317 | |
| Engine | 8060.05 | Injection Pump BOSCH | 79071380 | 20*31*7 | CORTECO | 12014600 | |
| Engine | 8060.06 | Rear Crankshaft 1°s. | 12011317 | 110*135*13 | CORTECO | 12011317 | |
| Engine | 8060.12 | Rear Crankshaft 1°s. | 70000720 | 95*120*13 | CORTECO | 12011314 | |
| Engine | 8060.24 | Injection Pump | 79045965 | 20*30*7 | CORTECO | 12001623 | |
| Engine | 8210.22 | Injection Pump | 12010846 | 25*35*7 | CORTECO | 12010846 | |
| Engine | 8210.42 | Rear Crankshaft | 40100600 | 140*165*15 | CORTECO | 12011323 | |
| Engine | 8280.02 | Injection Pump | 772333 | 25*35*7 | CORTECO | 12010846 | |
| Engine | 8280.22 | Injection Pump (Alternative) | 768343 | 25*35*7 | CORTECO | 12011122 | |
| Engine | 8040.05-25 | Injection Pump Drive Shaft | 79091380 | 20*31*7 | CORTECO | 12014600 | |
| Engine | 8060.45S | Front Crankshaft | 98488393 | 42*65*10 | CORTECO | 12016489 | |
| Engine | 806A | Rear Crankshaft | 40003760 | 74*90*10 | CORTECO | 12001483 | |
| Engine | 8340.04-05 | Injection Pump | 40000880 | 17*28*7 | CORTECO | 12011351 | |
| AUTOMATI CTRANSMI SSIO | AUTOMATIC TRANSMISSION/17 2 | input Gearbox outer side | 8836666 | 75*100*13 | CORTECO | 172 | |

| CAR | MODEL | APPLICATION | OEM NO. | SIZE | DATA acc. | CODE | YEARS |
|------------------------------|----------------------------------|-----------------------------------|--------------------------|---------------|-----------|------|-------|
| AUTOMATI CTRANSMI SSIO | AUTOMATIC TRANSMISSION17 3 | Rear main shaft outer side | 9981309 | 70*90*10 | CORTECO | 173 | |
| | AUTOMATIC TRANSMISSION/17 | output gearbox outer side | 40001900 | 90*110*13 | CORTECO | 172 | |
| | Engine/1/203H/61 | auxiliary shaft | 4587995 | 30*52*10 | CORTECO | 1 | |
| | Engine/2/220H | air compressor drive shaft | 40001820 | 38*50*7 | CORTECO | 2 | |
| | Engine/34/8140.27 | injection pump BOSCH | 79071380 | 20*31*7 | CORTECO | 34 | |
| | Engine/43/8180.97- 47 | injection pump BOSCH | 79023584 | 17*28*7 | CORTECO | 43 | |
| | Engine/61/8260.02 | injection pump (alternative) | 768343 | 25*35*7 | CORTECO | 61 | |
| | Engine/66/8340.04- 05 | injection pump ALTECNA | 773254 | 17*28*7 | CORTECO | 66 | |
| | Engine/67/8360.03- 04-05 | injection pump BOSCH | 1288064 | 17*28*7 | CORTECO | 67 | |
| | Engine/7/8040.02 | air compressor drive shaft | 40000560 | 25*47*10 | CORTECO | 7 | |
| | Engine/7/8040.02 | injection pump | 40000880 | 17*28*7 | CORTECO | 7 | |
| | Engine/7/8040.02 | rear crankshaft 2° | 40002810 | 110*135*13 | CORTECO | 7 | |
| | Engine/80/8460 | speed governor | 93190736 | 35*47*7 | CORTECO | 80 | |
| | Front Axle/197 | Out wheel hub | 8576283 | 70*90*10 | CORTECO | 197 | |
| | Front Axle/203 | Outer axle shaft | 3345907 | 45*65*10 | CORTECO | 203 | |
| | Front Axle/226 | wheel hub | 40001590 | 80*110*12 | CORTECO | 226 | |
| | Front Axle/228 | wheel hub | 40001880 | 75*100*13 | CORTECO | 228 | |
| | Front Axle/255 | wheel hub(alternative) | 40001030 | 110*130*13 | CORTECO | 255 | |
| | Front Axle/257 | wheel hub 1° s. | 4551424 | 110*130*13 | CORTECO | 257 | |
| | Front Axle/257 | wheel hub 2° s. | 4566349 | 125*150*13 | CORTECO | 257 | |
| | Intermediate | wheel hub | 40000480 | 145*170*13 | CORTECO | 273 | |
| | POWER TAKE OFF/464 | Shaft "PTO V50/047;069" | 42484578 | 55*80*10 | CORTECO | 464 | |
| | Rear Axle/317 | Wheel hub(altern) | 4008972 | 160*185*10 | CORTECO | 317 | |
| | Rear Axle/318 | Differential bevelgear(altern) | 40000750 | 70*112*12 | CORTECO | 318 | |
| | Rear Axle/318 | inner wheel hub(alternative) | 40001650 | 160*185*13 | CORTECO | 318 | |
| | Rear Axle/324 | axle shaft | 4459074 | 60*75*8 | CORTECO | 324 | |
| | Rear Axle/331 | wheel hub | 38510549 | 75*100*10 | CORTECO | 331 | |
| | Rear Axle/333 | wheel hub | 540727 | 80*110*13 | CORTECO | 333 | |
| | STEERING/488 | Worm screw | 2982310 | 25*40*7 | CORTECO | 488 | |
| | STEERING/491 | steering shaft | 1268104 | 35*47*7 | CORTECO | 491 | |
| | XL185 | Front folk | 91255-331-671 | 31*43*10.5 | | | |
| | | Front folk | 51153-08030, S0351-32000 | 30*42*10.5 | | | |
| | | Power Steering | AE8027E | 20*32.5*7/7.6 | NOK | | |
| | | power steering | | 19*38*7/8 | | | |
| | | power steering | | 20*35*8 | | | |
| | | power steering | | 20*40*7 | | | |
| | | power steering | | 22*35*8.5 | | | |
| | | power steering | | 22*36*7 | | | |
| | | power steering | AP1133G | 22*38*8 | NOK | | |
| | | power steering | | 22*38.5*8 | | | |
| | | power steering | BP2151E | 23*34*6.5 | NOK | | |
| | | power steering | | 23*35*6.5/7 | | | |
| | | power steering | | 23*37*9 | | | |
| | | power steering | | 23*40*9 | | | |
| | | power steering | | 23*41.2*8 | | | |
| | | power steering | | 24*34*7 | | | |

| CAR | MODEL | APPLICATION | OEM NO. | SIZE | DATA acc. | CODE | YEARS |
|-----|-------|------------------------|-----------------|--------------------|-----------|-----------|-------|
| | | power steering | AP8097G | 24*36*7 | NOK | | |
| | | power steering | | 24*36.5*8.5 | | | |
| | | power steering | | 24*38.2*8.5 | | | |
| | | power steering | | 24*40*7 | | | |
| | | power steering | | 24*40*8.5 | | | |
| | | power steering | BP2150I | 24*41*8.5 | NOK | | |
| | | power steering | BP2285E | 24*42*8.5 | NOK | | |
| | | power steering | | 24*43*7 | | | |
| | | power steering | | 25*35*8 | | | |
| | | power steering | | 25*37.5*7 | | | |
| | | power steering | | 25*38.5*8.5 | | | |
| | | power steering | | 25.5*39*8.5 | | | |
| | | power steering | | 25.5*41.1*8 | | | |
| | | power steering | | 25.5*42.5*8 | | | |
| | | power steering | | 25.5*44*8.5 | | | |
| | | power steering | | 26*45.2*7 | | | |
| | | power steering | | 27*41*8.5 | | | |
| | | power steering | | 27*42*7/10 | | | |
| | | power steering | | 27*42*9/10 | | | |
| | | power steering | | 27*43*8.5 | | | |
| | | power steering | | 27*46*13 | | | |
| | | power steering | | 28*39.9*4.2/6.5 | | | |
| | | power steering | | 28*44.5*9.5 | | | |
| | | power steering | | 30*42.5*8 | | | |
| | | power steering | | 30*46*8 | | | |
| | | power steering | | 30*48*8 | | | |
| | | power steering | | 35*50*8 | | | |
| | | Power Steering | | 17*32*7/8 | | | |
| | | Power Steering | | 18.5*30*5/5.7 | | | |
| | | Power Steering | | 19*29*5/6 | | | |
| | | Power Steering | BP6152E | 19*29*7.7/9 | NOK | | |
| | | Power Steering | BP0077G | 19*32*6.5/7 | NOK | | |
| | | Power Steering | | 20*36*7/8 | | | |
| | | Power Steering | BP6049E | 20.5*34.7*7/9 | NOK | | |
| | | Power Steering | BP6049E | 20.65*34.14*7/7.7 | NOK | | |
| | | Power Steering | | 22*32.5*5/5.5 | | | |
| | | Power Steering | BP4082E | 25*34*6/6.4 | NOK | | |
| | | Power Steering | | 25*35*5/6 | | | |
| | | Power Steering | | 25*36*5/5.5 | | | |
| | | Power Steering | | 32*40*7/8 | | | |
| | | Power Steering | MD-731708 | 39.5*52*10/11 | NOK | | |
| | | Power Steering | | 19*38*7/7.5 | | | |
| | | Power Steering | | 25*37.5/41.5*3/7.5 | | | |
| | | Power Steering | | 25*37.5/41.5*3/7.5 | | | |
| | | Power Steering | | 30*47*7 | | | |
| | | Power Steering | | 35*56*8 | | | |
| | | Power Steering | | 22*30*5/5.5 | | | |
| | | Power Steering | | 26*44*8.5 | | | |
| | | Power Steering | | 25*45*8 | | | |
| | | Power Steering | | 28*44.5*8.9 | | | |
| | | Power Steering | | 22*32*7 | NOK | AP1116-E0 | |
| | | Power Steering | | 27*42*8.5 | | | |
| | | Power Steering | 23711-01909-000 | 25*43*8 | | | |
| | | Power Steering | | 25*43*9 | | | |
| | | Power Steering | | 26*44*8 | | | |
| | | Power Steering | | 32*50*8.5 | | | |
| | | Power Steering | | 26*38*8.5 | | | |
| | | Power Steering | | 24*43*7.5 | | | |
| | | Power Steering | | 25*43*8 | | | |
| | | Spark Plug holder used | | 28.6*48.5*3.1/10.8 | | | |

| CAR | MODEL | APPLICATION | OEM NO. | SIZE | DATA acc. | CODE | YEARS |
|-------|------------------------------|-------------|-------------------------|----------------|-----------|------------|-------|
| | | | 09284-10002 | 10*17*5 | | | |
| | | | 116 997 02 46A | 100*124*13 | | | |
| | | | AP4063B0 | 100*125*13 | NOK | AP4063B0 | |
| | | | 8-09625-052-0 | 100*135/140*14 | NOK | AH7079R | |
| | | | BH2201-E | 101*116*8 | NOK | | |
| | | | AP 4153 H0 | 105*135*14 | NOK | AP 4153 H0 | |
| | | | BZ2374E | 108*180*17.5 | | | |
| | | | NB04885 | 11*25*3.5/9.2 | | | |
| | | | 91203-001-000 | 11.6*24*10 | | | |
| | | | AP4212G0 | 110*140*14 | NOK | AP4212G0 | |
| | | | AE 4221 E0 | 110*145*15 | NOK | AE4221E0 | |
| | | | BZ2524-E | 110*151*3/6.5 | NOK | | |
| | | | SE01-22-54 | 12*25*4.5 | | | |
| | | | AE0382A0 | 12*25*7 | NOK | AE0382A0 | |
| | | | 9640 003 1280 | 12*32*7 | | | |
| | | | AP4346B7 | 120*150*14 | NOK | AP4346B7 | |
| | | | 01735-BGE | 125*150*15 | | | |
| | | | AD 4399 A0 | 125*155*14 | NOK | AD 4399 A0 | |
| | | | W/BZ5333E | 133*157/165*18 | NOK | | |
| | | | 93104-14059 | 14*25*5 | | | |
| | | | 653G142507 | 14*25*7 | | | |
| | | | BR2227E | 14*26*12 | NOK | | |
| | | | 9283-15277 | 15*27*7 | | | |
| | | | SE01-15305 | 15*30*5 | | | |
| | | | 14658-43G00 | 15*30*7.5/8.5 | | | |
| | | | 90311-15327 | 15*32*7 | | | |
| | | | BW2410E | 152.4*180*17 | NOK | | |
| | | | 92049002 | 16*24*4 | | | |
| | | | 9828-01127 | 160*182*18 | | | |
| HONDA | NH80,起動軸,船外機,15/25HP,DT15,短軸 | | 48089-H5000 | 17*30*6 | | | |
| | | | AE0750E | 17*32*7 | NOK | | |
| | | | AW0751E | 17*32*8 | NOK | | |
| | | | AE0751G | 17*32*8 | NOK | | |
| | | | BH4243E | 18*33*6 | NOK | | |
| | | | AE 4943 E1 | 185*210*15 | NOK | AE 4943 E1 | |
| | | | DT193171 | 20*31*7.3 | | | |
| | | | 09283-20034 | 20*37*8 | | | |
| | | | BZ5179E | 22*34*6 | NOK | | |
| | | | F25-2301-0 | 23*35*6 | | | |
| | | | 12342-PM6-000 | 23.5*40.5*6.7 | | | |
| | | | BP5504E | 24*36*5.4/6.8 | NOK | | |
| | | | AD8851F | 24*36*6 | NOK | | |
| | | | AE1252E | 24*38*8 | NOK | | |
| | | | D350-1508-40 | 24*40*7 | | | |
| | | | 12342-PR3-000 | 25*36.5*6 | | | |
| | | | 48137-Z9005 | 25*38*7.5 | | | |
| | | | AE1315-FO | 25*40*10 | NOK | | |
| | | | AD 1314 F0 | 25*40*8 | NOK | AD 1314 F0 | |
| | | | AP1340E | 25*45*12.5 | NOK | AP1340E | |
| | | | 109-23145-00 | 26*36*10.5 | | | |
| | | | AE7479-P0 | 26*47*8 | NOK | | |
| | | | 11193-15010 | 26*48*10 | | | |
| | | | 90756118003, 2762314551 | 27*39*10.5 | | | |
| | | | 130536, 03100308 | 27*47*6 | | | |
| | | | AG1524P | 28*34*5 | NOK | | |
| | | | 2186-738-0350 | 30*40*8 | | | |
| | | | BH2825E | 30*41*8 | NOK | | |
| | | | 164-23145-01 | 30*42*11 | | | |
| | | | AP1709H | 30*50*11 | NOK | AP1709H | |

| CAR | MODEL | APPLICATION | OEM NO. | SIZE | DATA acc. | CODE | YEARS |
|-----|-------|-------------|--------------------|------------------------|-----------|------------|-------|
| | | | 91255-3331 | 31*43*10.5 | | | |
| | | | AC8176P | 31*65/80*15 | NOK | | |
| | | | BD1355F | 32*65*12 | NOK | | |
| | | | 481253-058142 | 34.5*75/76*11/12 | | | |
| | | | BD3298F | 34.7*65*12 | NOK | | |
| | | | 1T323-14500 | 35*48*11 | | | |
| | | | BH3290E | 35*50*11.5 | NOK | | |
| | | | AP 2085 G1 | 35*55*11 | NOK | AP 2085 G1 | |
| | | | 9828-37105 | 37*57*10 | PAYEN | NK114 | |
| | | | AP2240G | 38*58*11 | NOK | AP2240G | |
| | | | BH6045E | 38*63*9/15.5 | NOK | | |
| | | | G030-26-154A | 39*50*7 | | | |
| | | | AD2314E | 39.29*80.16*7.14/18.64 | NOK | | |
| | | | 3461793 | 40*52/62*8.5/7 | MUSASHI | | |
| | | | AP2378F | 40*60*12 | NOK | AP2378F | |
| | | | AP2388E | 40*62*11 | NOK | AP2388E | |
| | | | AE6831E | 40*62/72*13.5 | NOK | | |
| | | | BH6492E | 40*64*8/14.5 | NOK | | |
| | | | BH4989E | 40.08*57.15*7.95/17.07 | NOK | | |
| | | | BH6382E | 41*53*6 | NOK | | |
| | | | BH6332E | 41*74*11/18 | NOK | | |
| | | | AP 2507 H2 | 42*65*12 | NOK | AP 2507 H2 | |
| | | | AH7689E | 43.26*68.07*7.95 | NOK | | |
| | | | AP2653-E0 | 45*62*12 | NOK | AP2653-E0 | |
| | | | AP2659E | 45*65*12 | NOK | AP2659E | |
| | | | AP2668G | 45*68*12 | NOK | AP2668G | |
| | | | AE 2666 E0 | 45*68*9 | NOK | AE 2666 E0 | |
| | | | MT045A3 | 45*70*12/19 | | | |
| | | | BH5320E | 47*69*10/16.5 | NOK | | |
| | | | BE3683E | 47*84*9.5/17.5 | NOK | | |
| | | | 90311-47029T | 47.6*70.64*13.5 | | | |
| | | | 90311-48007/08 | 48*72*8 | | | |
| | | | BG4415E | 48*75*7.5/11.5 | NOK | | |
| | | | W029-261-57 | 49*56*8 | | | |
| | | | 09285-05004 | 5.5*16*8 | | | |
| | | | 02442-BAGE (Print) | 50*65.2*9.7/14 | | | |
| | | | AP2864I | 50*72*12 | NOK | AP2864I | |
| | | | AH2861E | 50*72*9/15.5 | NOK | | |
| | | | BH6493E | 50*80*11/18 | NOK | | |
| | | | 90313-54001 | 54*64*9/24 | | | |
| | | | UP0803E | 55*75*12 | NOK | UP0803E | |
| | | | AP3055F | 55*78*12 | NOK | AP3055F | |
| | | | BZ5051E | 55*78*12/16 | NOK | | |
| | | | | 56*71/77.7*6.5/14 | | | |
| | | | MB-633434 | 57*76*7/10 | | | |
| | | | 91201-324-013 | 6.5*14.5*7 | | | |
| | | | AP3222B | 60*82*12 | NOK | AP3222B | |
| | | | 9828-62103 AD3286 | 62*76*9 | | | |
| | | | BF1668F | 62*78*7/9.5 | NOK | | |
| | | | BD4996E | 62*83/92*6.5/17 | NOK | | |
| | | | | 68*90*13 | | | |
| | | | AP 3527 B9 | 70*95*13 | NOK | AP 3527 B9 | |
| | | | BH6133F | 73*89*8.5 | NOK | | |
| | | | BH6133E | 73.5*89*8.5 | NOK | | |
| | | | AP3618G | 75*100*13 | NOK | AP3618G | |
| | | | BH6249E | 75*107*8 | NOK | | |
| | | | 90311-75016 | 75*107*8 | | | |
| | | | BH5768E | 76*94*8.5 | NOK | | |
| | | | BH5704E | 79*99*8 | NOK | | |
| | | | AR0139-E | 8*17.4*5/7 | NOK | | |

| CAR | MODEL | APPLICATION | OEM NO. | SIZE | DATA acc. | CODE | YEARS |
|-----|-------|---------------------------------|---------------|-----------------------|-----------|--------------|-------|
| | | | 91203-292-005 | 8*34*8 | | | |
| | | | 006 99 79 047 | 8.5*16*13 | | | |
| | | | BH6381E | 83*103*8 | NOK | | |
| | | | BH5861F | 84*104*8.5 | NOK | | |
| | | | 103204-02890 | 87*98*6 | | | |
| | | | 103204-02880 | 87.5*98*6 | | | |
| | | | 103203-02220 | 88*98*6 | | | |
| | | | AP3932B(NOK) | 90*115*13 | NOK | AP3932B(NOK) | |
| | | | BZ5000 | 93*114*8/17 | NOK | | |
| | | | BF2991F | 93*154*8/11.4 | NOK | | |
| | | | BH5676E | 95*114*12 | NOK | | |
| | | | ME-202851 | 95*114*12 | | | |
| | | | | 10*18*5/8 | | | |
| | | | | 15*35*9.5/18 | | | |
| | | SHOCK ABSORBER | 92613-9547 | 18*30*10/15 | | | |
| | | SHOCK ABSORBER | | 20*30*10/15 | | | |
| | | SHOCK ABSORBER | 90313-20005 | 20*32*10/15 | | | |
| | | SHOCK ABSORBER | | 20*36*10/15 | | | |
| | | SHOCK ABSORBER | 90316-22003 | 22*34*10/15 | | | |
| | | SHOCK ABSORBER | 90316-20006 | 20*34*10/15 | NTK | | |
| | | SHOCK ABSORBER | | 22*36*7.5/11 | | | |
| | | SHOCK ABSORBER | | 22*36*7/10 | | | |
| | | SHOCK ABSORBER | | 25*37*10/15 | | | |
| | | SHOCK ABSORBER | AR1309-P | 25*38*10/15 | NOK | | |
| | | SHOCK ABSORBER | 90316-25016 | 25*38*10/15 | | | |
| | | SHOCK ABSORBER | | 28*38*10/15 | | | |
| | | SHOCK ABSORBER | | 22*33*10/15 | | | |
| | | | | 32*62*12 | | | |
| | | | | 1.125*1.494*0.25 | | | |
| | | | | 10*16*6 | | | |
| | | | AE0258-G0 | 10*20*5 | Simrit | | |
| | | | | 10*21*5 | | | |
| | | | | 10*21*5 | | | |
| | | | | 100*120*10 | | | |
| | | | | 100*125*8 | | | |
| | | | | 100.03*127*12.7 | | | |
| | | | | 101.6*127*12.7 | | | |
| | | | | 104*139*13 | | | |
| | | | | 105*140*12 | | | |
| | | | | 109*137*13 | | | |
| | | | | 11*17*4 | | | |
| | | | | 110*130*12 | | | |
| | | | | 110*135*13 | | | |
| | | | BA2784E | 110*136/165*12.5/26.5 | | | |
| | | | | 110*140*14 | | | |
| | | Concrete Mixer Gear Box User | 0750-12-169 | 110*180/202*12.5/49.5 | | | |
| | | | | 115*150*15 | | | |
| | | | | 117.48*152.4*27 | | | |
| | | | | 12*16*3/4 | | | |
| | | | | 12*18*5 | | | |
| | | | | 12*18*5 | | | |
| | | | | 12*18*5 | | | |
| | | | | 12*19*7 | | | |
| | | | | 12*21*7 | | | |
| | | | | 12*24*5 | | | |
| | | | AE8515-E0 | 12*24*5 | Simrit | | |
| | | | | 12*25*6 | | | |
| | | | AD0382A3 | 12*25*7 | NOK | | |
| | | | | 12*28*7 | | | |
| | | | | 12*28*7 | | | |

| CAR | MODEL | APPLICATION | OEM NO. | SIZE | DATA acc. | CODE | YEARS |
|-----|-------|-------------|---------------------|-----------------------------|-----------|------|-------|
| | | | | 12*32/36.5*12.6/15.3 | | | |
| | | | | 12.45*22*6 | | | |
| | | | | 12.7*25.4*6.35 | | | |
| | | Dodge-Fargo | | 12.7*28.58*7.14 | DBH | 5497 | |
| | | | | 12.7*28.58*7.14 | | | |
| | | | | 120*140*13 | | | |
| | | | | 120*165*10 | | | |
| | | | | 120.65*146.05*12.7 | | | |
| | | | | 13*19*4 | | | |
| | | | AD7164-E0;BDD964-A0 | 13*22*5.5 | Simrit | | |
| | | | | 13*30*7 | | | |
| | | | | 132*152*13 | | | |
| | | | | 135*175*15 | | | |
| | | | | 14*24*7/7.5 | | | |
| | | | AE0516-E0 | 14*24*8 | Simrit | | |
| | | | | 14*26*5 | | | |
| | | | | 14*27*7 | | | |
| | | | | 14*35*7 | | | |
| | | | | 14*35*7 | | | |
| | | | | 14.3*28.58*6.35 | | | |
| | | | | 14.3*28.58*6.35 | | | |
| | | | | 14.8*35*7.5/9 | | | |
| | | | | 145*170*13 | | | |
| | | | | 145*175*15 | | | |
| | | | | 145*180*12 | | | |
| | | | | 145*180*15 | | | |
| | | | | 145*190*16 | | | |
| | | | | 149.23*174.63*12.7 | | | |
| | | | | 15*24*6.5/7 | | | |
| | | | | 15*24*7 | | | |
| | | | | 15*25*5 | | | |
| | | | | 15*26*5.5/6.5 | | | |
| | | | | 15*26*6.5/7 | | | |
| | | | | 15*28*7 | | | |
| | | | | 15*30*5.5/5.9 | | | |
| | | | | 15*42*10 | | | |
| | | | | 15.88*25.4*6.35 | | | |
| | | | | 15.88*28.58*6.35 | | | |
| | | | | 150*190*15 | | | |
| | | | | 152.4*177.8*12.7 | | | |
| | | | | 16*24*5 | | | |
| | | | | 16*26*5 | | | |
| | | | | 16*27*6 | | | |
| | | | | 16*30*4.5 | | | |
| | | | | 16*38*8 | | | |
| | | | | 16*40*7 | | | |
| | | | | 16*40*7 | | | |
| | | | | 16.28*27.98*5.16 | | | |
| | | | | 16.4*30*5 | | | |
| | | | | 162*182*14 | | | |
| | | | | 165*200*15 | | | |
| | | | | 17*30*10 | | | |
| | | | | 17*30*7/7.5 | | | |
| | | | | 17*32*5 | | | |
| | | | | 17.48*28.58*7.95 | | | |
| | | | | 17.48*30.18*7.95 | | | |
| | | | | 17.86*27.79/34.92*4.37/6.76 | | | |
| | | | | 170*190*15 | | | |
| | | | | 18*26*4.5 | | | |
| | | | | 18*28*8 | | | |
| | | | | 18*30*7 | | | |

| CAR | MODEL | APPLICATION | OEM NO. | SIZE | DATA acc. | CODE | YEARS |
|-----|-------|-------------|------------|-------------------------|-----------|----------|-------|
| | | | | 18*32*6 | | | |
| | | | | 18*32*7.9 | | | |
| | | | | 19*25*6 | | | |
| | | | AE0875A0 | 19*35*8 | NOK | AE0875A0 | |
| | | | AE0875A0 | 19*35*8 | NOK | AE0875A0 | |
| | | | | 19*35*8 | | | |
| | | | | 19.05*41.28*6.35 | | | |
| | | | | 19.8*30*5 | | | |
| | | | FQ0014C0 | 20*28*4.5/6 | NOK | | |
| | | | | 20*28*5/7 | | | |
| | | | | 20*30*4.5 | | | |
| | | | | 20*30*6 | | | |
| | | | AW 1015 E0 | 20*35*10 | NOK | | |
| | | | | 20*36*10 | | | |
| | | | | 20*38*5/7 | | | |
| | | | | 20*40*8 | | | |
| | | | | 20*42*6 | | | |
| | | | | 20*50*10 | | | |
| | | | | 21*40*10 | | | |
| | | | | 21*45*10 | | | |
| | | | | 21*45*7 | | | |
| | | | | 21.6*35*7 | | | |
| | | | AD1116-E1 | 22*32*7 | Simrit | | |
| | | | | 22*32*8 | | | |
| | | | | 22*36.5*6.5 | | | |
| | | Industrial | | 22*48*10 | DBH | 9121 | |
| | | | | 23*34*7 | | | |
| | | | | 23*35/41*12/16 | | | |
| | | | | 23*37*7 | | | |
| | | | | 23*38*5 | | | |
| | | | | 23.43*29.77*3.96/6.76 | | | |
| | | | | 23.83*31.34/41.28*16.66 | | | |
| | | | | 24*36.5*6.5/9 | | | |
| | | | | 24*38*7 | | | |
| | | | | 24*40*7.3/9.5 | | | |
| | | | | 24.61*40.5/48.5*3.2/9 | | | |
| | | | | 25*32*4 | | | |
| | | | | 25*33*4 | | | |
| | | | | 25*35*6/9 | | | |
| | | | | 25*35*9/10 | | | |
| | | | | 25*38*6 | | | |
| | | | | 25*40*9 | | | |
| | | | | 25*42*7 | | | |
| | | | | 25*48*10/11 | | | |
| | | | | 25*50*10 | | | |
| | | | BCC159-A1 | 25*52*7 | NOK | | |
| | | | | 25.4*41.25*6.35 | | | |
| | | | | 25.4*47.63*9.52 | | | |
| | | | | 25.4*50.8*12.7 | | | |
| | | | | 25.81*34.92/42.47*16.2 | | | |
| | | | | 25.81*45.24*10.72 | | | |
| | | | | 250*280*15 | | | |
| | | | | 26*35*7 | | | |
| | | | | 27*33*4 | | | |
| | | | | 27*34*4 | | | |
| | | | | 27*35*4 | | | |
| | | PlusSeals | | 27*44*7.5/10.5 | | | |
| | | | | 27*49*10/11 | | | |
| | | | | 28*35*4 | | | |
| | | | | 28*38*7 | | | |
| | | | | 28*38.3*7.5 | | | |





| CAR | MODEL | APPLICATION | OEM NO. | SIZE | DATA acc. | CODE | YEARS |
|-----|------------------|--------------|-------------|------------------------------|-----------|--------|---------|
| | | | | 28*40*6/7 | | | |
| | | | | 28*42*6 | | | |
| | | | | 28*43*8 | | | |
| | | | | 28*48*6 | | | |
| | | | | 28*48*7 | | | |
| | | | | 28*60*10 | | | |
| | | | | 28.58*41.28*6.35 | | | |
| | | | | 28.58*41.28*6.35 | | | |
| | | | | 28.58*47.63*11.13 | | | |
| | | | | 28.58*50.8*6.35 | | | |
| | | | | 29*50*10 | | | |
| | | | | 290*330*18 | | | |
| | | | | 30*36*6 | | | |
| | | | | 30*37*6.5 | | | |
| | | | | 30*37*7 | | | |
| | | | | 30*38.5*6 | | | |
| | | | | 30*39*7 | | | |
| | | | | 30*40*5 | | | |
| | | | | 30*41*7 | | | |
| | | | | 30*43*7 | | | |
| | | | | 30*46*11 | | | |
| | | | | 30*47*10 | | | |
| | | | | 30*48*6 | | | |
| | | | | 30*50*10 | | | |
| | | | | 30*50*12 | | | |
| | | | | 30*70*10 | | | |
| | | | | 30.18*47.63*6.35 | | | |
| | | | | 30.96*44.45*7.95 | | | |
| | | | | 31.75*44.45*6.35 | | | |
| | | | | 31.75*44.45*6.35 | | | |
| | | | | 32*39*6/8 | | | |
| | | | | 32*40*7 | | | |
| | | | | 32*43*10.5 | | | |
| | CM80.85.86.87.90 | Transmission | 32219-Z5000 | 32*45*8 | PAYEN | NJ 416 | 5/85-on |
| | | | | 32*50*7 | | | |
| | | | | 32*50*8 | | | |
| | | | | 32*54*8 | | | |
| | | | | 32*55*6.5 | | | |
| | | | | 32*55*7 | | | |
| | | | | 32*57*8 | | | |
| | | | | 33*44*9 | | | |
| | | | | 33*46*8 | | | |
| | | | | 33*54*8 | | | |
| | | | | 34*45*8 | | | |
| | | | | 34*53*8 | | | |
| | | | | 34.92*50.8*6.35 | | | |
| | | | | 34.92*53.97*7.95 | | | |
| | | | | 34.93*54.91/61*9.12/14.68 | CR | 13750 | |
| | | | | 34.93*57.15/63.5*11.13/22.63 | CR | 13685 | |
| | | | | 35*100*10 | | | |
| | | | AF2028-E1 | 35*42*4 | Simrit | | |
| | | | | 35*42*5 | | | |
| | | | | 35*47*7 | | | |
| | | | | 35*47*8 | | | |
| | | | | 35*47*9 | | | |
| | | | | 35*48*11 | | | |
| | | | AD2048F0 | 35*48*8 | NOK | | |
| | | | AD2048F0 | 35*48*8 | NOK | | |
| | | | | 35*53*12 | | | |
| | | | | 35*54*8 | | | |
| | | | | 35*54*8 | | | |







| CAR | MODEL | APPLICATION | OEM NO. | SIZE | DATA acc. | CODE | YEARS |
|-----|-------|----------------|---------|------------------------------|-----------|----------|-------|
| | | | | 35*55*11 | | | |
| | | | | 35*55*11 | | | |
| | | | | 35*56*10 | | | |
| | | | | 35*56*7 | | | |
| | | | | 35*56/63.6*16 | CR | 14007 | |
| | | | | 35*57*8 | | | |
| | | | | 35*57/64*9.7/16 | CR | 13735 | |
| | | | | 35*58/67*11/19 | CR | 13757 | |
| | | | | 35*62*7/7.5 | | | |
| | | | | 35*67*12/20 | | | |
| | | | | 35*70*10 | | | |
| | | General Motors | | 35.53*58.21*13.2 | DBH | 5533 | |
| | | | | 35.53*63.09/67.87*8.14/13.08 | CR | 14393 | |
| | | | | 36*50*10 | | | |
| | | | | 36*52*8 | | | |
| | | | | 36*62*7 | | | |
| | | | | 36.5*50.8*7.9 | | | |
| | | | | 36.53*50.8*7.95 | | | |
| | | | | 36.53*50.8*7.95 | | | |
| | | | | 36.53*52.4*12.7 | | | |
| | | | | 37*50*11 | | | |
| | | | | 37*52*8 | | | |
| | | | | 38*54*12.5/27.5 | CR | 14234 | |
| | | | | 38*54*8 | | | |
| | | | | 38*72*8 | | | |
| | | | | 38*74*11 | | | |
| | | | | 38*74*11/18 | | | |
| | | | | 38.1*50.8*6.3 | | | |
| | | | | 38.1*50.8*7.95 | | | |
| | | | | 38.1*50.8*7.95 | | | |
| | | | | 38.1*60.33*11.91/16.66 | CR | 15015 | |
| | | | | 38.1*69.85*9.53 | | | |
| | | | | 38.71*67.46/76.2*10.77 | CR | 15306 | |
| | | | | 38.71*67.52/75.01*15.7 | CR | 15306 | |
| | | | | 39*50*10 | | | |
| | | | | 39*52*11 | | | |
| | | | | 39*52*7 | | | |
| | | | | 39*65*9/15 | | | |
| | | | | 39*71/80*6/16 | | | |
| | | | | 39*76.5*10.5/14 | | | |
| | | | | 39.29*53.57*8.33/23.42 | DBH | 99044 | |
| | | | | 39.29*62.12/68*11/14.68 | CR | 15629 | |
| | | | | 39.42*62.15*12.7/16.66 | CR | 15540 | |
| | | | | 39.42*68/80.26*7.1/17.6 | | | |
| | | | | 39.42*69.85*6.76/15.09 | CR | 15502 | |
| | | | | 39.5*72/78*11/14.5 | | | |
| | | | | 39.7*55.17/62.12*13.11 | CR | 15716 | |
| | | | | 4*12*5 | | | |
| | | | | 40*52*6/6.5 | | | |
| | | | | 40*52/58*7.6 | DBH | 01988BRG | |
| | | | | 40*53*7 | | | |
| | | | | 40*55/65*8.2 | | | |
| | | | | 40*57.15*10 | | | |
| | | | | 40*62*10 | | | |
| | | | | 40*72*8 | | | |
| | | | | 40*75*12/19 | CR | 15882 | |
| | | | | 40*75*8 | | | |
| | | | | 40*78/84.5*13.5/18 | | | |
| | | | | 40.01*58.17/64.1*9.14 | CR | 15750N | |
| | | | | 40.5*52.5*6.5 | | | |
| | | | | 41*53*8 | | | |







| CAR | MODEL | APPLICATION | OEM NO. | SIZE | DATA acc. | CODE | YEARS |
|-----|-------|-------------|-----------|------------------------------|-----------|----------|-------|
| | | | | 41*53*8 | | | |
| | | | | 41*58*9/12.7 | CR | 16015 | |
| | | | | 41.28*63.5*12.7 | | | |
| | | | | 42*54*10 | | | |
| | | | | 42*58*10 | | | |
| | | | | 42*60*9 | | | |
| | | | | 42*62*10/10.5 | | | |
| | | | | 42*65*12 | | | |
| | | | AP2507H2 | 42*65*12 | NOK | AP2507H2 | |
| | | | ME-240328 | 42*66*11.5/18.5 | | | |
| | | | | 42*76*10 | | | |
| | | | | 42.88*63.55/73.03*9.98/21.21 | CR | 16725 | |
| | | | | 42.88*66.62/80.16*13.46 | CR | 16805 | |
| | | | | 42.88*78.3/83*11.91/13.75 | CR | 17005 | |
| | | | | 42.88*78.63/87.91*13.89 | CR | 17037 | |
| | | | | 43*58*7 | | | |
| | | | | 43*58*8 | | | |
| | | | | 43*65*8 | | | |
| | | | | 44*60*10 | | | |
| | | | | 44*60*7 | | | |
| | | | | 44.04*59.13/66.8*7.95 | CR | 17815 | |
| | | | | 44.37*66.62/72.82*9.27 | CR | 17458 | |
| | | | | 44.45*60.3*11.13 | | | |
| | | | | 44.45*63.5*9.5 | | | |
| | | | | 44.45*65.1*7.95 | | | |
| | | | | 44.45*68.26*16.5 | | | |
| | | | | 44.45*69.85*7.93 | | | |
| | | | | 44.96*63.5/77.39*10.85 | CR | 17787 | |
| | | | | 45*100*10 | | | |
| | | | | 45*100*10 | | | |
| | | | | 45*52*4 | | | |
| | | | | 45*54*5.7/9 | DBH | 560361 | |
| | | | | 45*55*5 | | | |
| | | | | 45*55*7 | | | |
| | | | | 45*55*7 | | | |
| | | | | 45*60*6 | | | |
| | | | | 45*60*7 | | | |
| | | | | 45*60*8 | | | |
| | | | AP2653 | 45*62*12 | Simrit | AP2653 | |
| | | | | 45*63*7.5 | | | |
| | | | | 45*64*7 | | | |
| | | | | 45*65*7 | | | |
| | | | | 45*67*7 | | | |
| | | | | 45*68*8.5 | | | |
| | | | | 45.6*56*7 | | | |
| | | | | 45.95*59.97/72.82*9.53 | CR | 18009 | |
| | | | | 46*62*7 | | | |
| | | | | 46*62*8/14 | | | |
| | | | | 46.05*78.54/86.92*12.7/15.47 | CR | 18024 | |
| | | | | 47*80*10/16 | | | |
| | | | | 48*58*4 | | | |
| | | | | 48*64*12 | | | |
| | | | | 48*64*12/7.4 | | | |
| | | | | 48*65*10.3 | | | |
| | | | | 48*65*12 | | | |
| | | | | 48*65*8 | | | |
| | | | | 48*67*10 | | | |
| | | | AD2791A3 | 48*70*12 | NOK | | |
| | | | | 48*82*12/19 | | | |
| | | | | 48*90*10 | | | |
| | | | | 49.23*69.85*9.53 | | | |







| CAR | MODEL | APPLICATION | OEM NO. | SIZE | DATA acc. | CODE | YEARS |
|-----|-------|-------------|----------|-------------------------|-----------|----------|-------|
| | | | | 5*14*4 | | | |
| | | | | 5*18*7 | | | |
| | | | | 50*100*10 | | | |
| | | | | 50*100*12 | | | |
| | | | | 50*60*10 | | | |
| | | | | 50*60*5 | | | |
| | | | | 50*65*8 | | | |
| | | | | 50*66/75*9.3/14 | | | |
| | | | AE2857E0 | 50*70*12 | NOK | AE2857E0 | |
| | | | AE2862E1 | 50*72*10 | NOK | | |
| | | | | 50*72*12 | | | |
| | | | | 50*75*12 | | | |
| | | | | 50*75*9 | | | |
| | | | | 50*78*10 | | | |
| | | | | 50*80*7 | | | |
| | | | | 50*90*10 | | | |
| | | | | 50*90*13 | | | |
| | | | | 50.39*63.5*8.5 | | | |
| | | | | 50.8*66.68*6.35 | | | |
| | | | | 51*65*7 | | | |
| | | | | 52*112*10.5/15.5 | | | |
| | | | AW2969E | 52*75*14/20.5 | NOK | | |
| | | | | 53.97*76.2*9.53 | | | |
| | | | | 53.98*79.78*11.13/14.68 | | | |
| | | | | 53.98*79.98*9.9/12.7 | | | |
| | | | | 54*66*7 | | | |
| | | | | 54*73*10 | | | |
| | | | | 54*78*12 | | | |
| | | | | 55*110*10 | | | |
| | | | FD3033E1 | 55*69*8/11 | NOK | | |
| | | | | 55*72*10 | | | |
| | | | | 55*75*12 | | | |
| | | | | 55*90*12 | | | |
| | | | | 55.58*76.2*9.53 | | | |
| | | | | 55.58*84.15*13.11/14.3 | | | |
| | | | | 56*69*7.5/17.7 | | | |
| | | | | 56*80*8 | | | |
| | | | | 58*68*4 | | | |
| | | | | 58*72*9 | | | |
| | | | | 58*72*9 | | | |
| | | | | 58.72*79.37*9.5 | | | |
| | | | | 59.06*79.43*9.27 | | | |
| | | | | 6*19*4 | | | |
| | | | | 60*70*8 | | | |
| | | | | 60*74*10 | | | |
| | | | | 60*75*9/9.5 | | | |
| | | | | 60*80*10 | | | |
| | | | | 60*80*7/10 | | | |
| | | | | 60*82*11/14 | | | |
| | | | AD3222I0 | 60*82*12 | NOK | | |
| | | | | 60*85*13 | | | |
| | | | | 60.33*82.55*9.53 | | | |
| | | | | 60.33*85.73*12.7 | | | |
| | | | | 60.33*85.73*22.23 | | | |
| | | | | 62*77*9 | | | |
| | | | AD3297E0 | 62*85*12 | NOK | | |
| | | | | 62*85*12 | | | |
| | | | | 62*85*8 | | | |
| | | | | 63.5*76.2*12.7 | | | |
| | | | | 65*77*9 | | | |
| | | | | 68*85*10 | | | |







| CAR | MODEL | APPLICATION | OEM NO. | SIZE | DATA acc. | CODE | YEARS |
|-----|-------|-------------|----------|-------------------|-----------|---------|-------|
| | | | | 68*90*10 | | | |
| | | | | 69.85*89.99*10.31 | CR | 27292 | |
| | | | | 7.95*12.8*3.58 | | | |
| | | | | 70*105*10 | | | |
| | | | | 70*120*14 | | | |
| | | | | 70*125*12 | | | |
| | | | | 70*90*12 | | | |
| | | | | 72*105*12 | | | |
| | | | | 73.02*101.6*12.7 | | | |
| | | | | 73.02*98.43*12.7 | | | |
| | | | | 73.03*101.6*15.88 | | 28761 | |
| | | | | 74*90*10 | | | |
| | | | | 75*100*10 | | | |
| | | | | 75*100*12/13 | | | |
| | | | | 75*90*13 | | | |
| | | | | 75*95*12 | | | |
| | | | | 75*95*12 | | | |
| | | | AE3611E | 75*95*13 | NOK | AE3611E | |
| | | | | 76.2*107.95*11.13 | | | |
| | | | | 76.2*114.3*11.13 | | | |
| | | | | 8*12*4 | | | |
| | | | | 8*14*5 | | | |
| | | | | 8*18*5 | | | |
| | | | | 80*110*10 | | | |
| | | | | 80*110*12 | | | |
| | | | | 80*115*15 | | | |
| | | | | 80*98*7 | | | |
| | | | | 82*105*12 | | | |
| | | Industrial | | 82*110*12 | DBH | 8976 | |
| | | | | 82.55*107.95*9.53 | | | |
| | | | | 82.55*114.3*11.13 | | | |
| | | | | 85*105*13 | | | |
| | | | AD3842H1 | 85*110*13 | NOK | | |
| | | | | 87.33*120.65*12.7 | | | |
| | | | | 88*114*12 | | | |
| | | | | 88.9*122.99*22.96 | | | |
| | | | | 9*19*5 | | | |
| | | | | 90*110*10 | | | |
| | | | | 90*120*12 | | | |
| | | | | 90*125*13 | | | |
| | | | | 95*137/175*12/29 | CORTECO | 58709 | |
| | | | | 96.85*123.82*12.7 | | | |
| | | | | 98*116*10 | | | |
| | | | | 98*130*12 | | | |





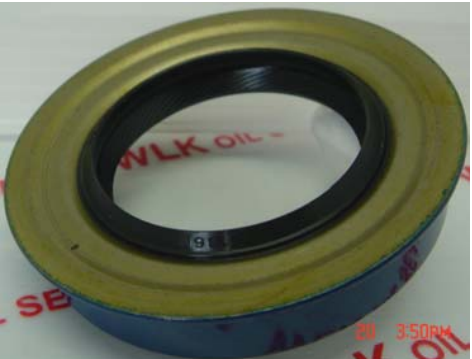

| CODE | TYPE | SIZE | PHOTO FRONT | PHOTO BACK |
|------|--------|------------------------|---|---|
| 2081 | TBP | 72.22*100.05*12.57 |  <p>Front view of oil seal #2081. The seal is black with a yellow outer ring and a red inner ring. It is shown against a white background with 'WLK OIL SEALS' printed in red. A timestamp '20 3:10PM' is visible in the bottom right corner.</p> |  <p>Back view of oil seal #2081. The seal is black with a yellow outer ring and a red inner ring. It is shown against a white background with 'WLK OIL SEALS' printed in red. A timestamp '20 3:10PM' is visible in the bottom right corner.</p> |
| 2689 | HTBG9W | 47.63*73.08*9.93/12.45 |  <p>Front view of oil seal #2689. The seal is black with a yellow outer ring. It is shown against a white background with 'WLK OIL SEALS' printed in red. A timestamp '17 1:25PM' is visible in the bottom right corner.</p> |  <p>Back view of oil seal #2689. The seal is black with a yellow outer ring. It is shown against a white background with 'WLK OIL SEALS' printed in red. A timestamp '17 1:26PM' is visible in the bottom right corner.</p> |

| CODE | TYPE | SIZE | PHOTO FRONT | PHOTO BACK |
|------|------|-----------------------|---|--|
| 4160 | KB9 | 61.47*76.2*7.14/9.93 |  A photograph showing the front view of a black oil seal with a red and yellow outer ring. The seal is placed on a white surface with red text that reads "OIL SEALS WLK". A timestamp "20 3:39PM" is visible in the bottom right corner. |  A photograph showing the back view of the same black oil seal with a red and yellow outer ring. The seal is placed on a white surface with red text that reads "OIL SEALS WLK". A timestamp "20 3:39PM" is visible in the bottom right corner. |
| 4250 | HTB5 | 63.5*83.90/90.88*9.53 |  A photograph showing the front view of a black oil seal with a yellow and red outer ring. The seal is placed on a white surface with red text that reads "OIL SEALS WLK". A timestamp "20 3:39PM" is visible in the bottom right corner. |  A photograph showing the back view of the same black oil seal with a yellow and red outer ring. The seal is placed on a white surface with red text that reads "OIL SEALS WLK". A timestamp "20 3:39PM" is visible in the bottom right corner. |
| 4316 | VAJR | 49.40*81.13*11.18 |  A photograph showing the front view of a white oil seal with a grey and red outer ring. The seal is placed on a white surface with red text that reads "OIL SEALS WLK". A timestamp "17 1:39PM" is visible in the bottom right corner. |  A photograph showing the back view of the same white oil seal with a grey and red outer ring. The seal is placed on a white surface with red text that reads "OIL SEALS WLK". A timestamp "17 1:39PM" is visible in the bottom right corner. |



| CODE | TYPE | SIZE | PHOTO FRONT | PHOTO BACK |
|------|------|-------------------------|---|--|
| 5121 | KB9 | 49.28*66.60*6.35/13.49 |  <p>A photograph showing the front view of a red oil seal with a black inner ring. The seal is placed on a white surface with red text that reads 'WALKER OIL SEALS'. A timestamp '20 3:30' is visible in the bottom right corner of the image.</p> |  <p>A photograph showing the back view of the same red oil seal with a black inner ring. The seal is placed on a white surface with red text that reads 'WALKER OIL SEALS'. A timestamp '20 3:30' is visible in the bottom right corner of the image.</p> |
| 5125 | Y | 50.8*66.62/76.99*16.13 |  <p>A photograph showing the front view of a red oil seal with a black inner ring and a gold-colored outer ring. The seal is placed on a white surface with red text that reads 'WALKER OIL SEALS'. A timestamp '20 3:30' is visible in the bottom right corner of the image.</p> |  <p>A photograph showing the back view of the same red oil seal with a black inner ring and a gold-colored outer ring. The seal is placed on a white surface with red text that reads 'WALKER OIL SEALS'. A timestamp '20 3:30' is visible in the bottom right corner of the image.</p> |
| 5778 | TB59 | 39.42*71.04/80.26*13.46 |  <p>A photograph showing the front view of a red oil seal with a black inner ring and a green outer ring. The seal is placed on a white surface with red text that reads 'WALKER OIL SEALS'. A timestamp '17 1:30PM' is visible in the bottom right corner of the image.</p> |  <p>A photograph showing the back view of the same red oil seal with a black inner ring and a green outer ring. The seal is placed on a white surface with red text that reads 'WALKER OIL SEALS'. A timestamp '17 1:30PM' is visible in the bottom right corner of the image.</p> |

| CODE | TYPE | SIZE | PHOTO FRONT | PHOTO BACK |
|------|-------|----------------------------|--|---|
| 6815 | KB5 | 49.28*63.5/68.66*6.35/7.14 |  A photograph showing the front view of a circular oil seal. It has a black inner lip, a yellowish-brown outer ring, and a red base. The seal is resting on a white surface with red text that reads "WLK OIL SEALS". A timestamp "20 3:46PM" is visible in the bottom right corner. |  A photograph showing the back view of the same oil seal. It features a black inner lip, a yellowish-brown outer ring, and a red base. The seal is resting on a white surface with red text that reads "WLK OIL SEALS W". A timestamp "20 3:46PM" is visible in the bottom right corner. |
| 8660 | SBP | 35.53*58.21*11.68 |  A photograph showing the front view of a circular oil seal. It has a black inner lip, a yellowish-brown outer ring, and a red base. The seal is resting on a white surface with red text that reads "SEALS". A timestamp "20 3:33P" is visible in the bottom right corner. |  A photograph showing the back view of the same oil seal. It features a black inner lip, a yellowish-brown outer ring, and a red base. The seal is resting on a white surface with red text that reads "SEALS". A timestamp "20 3:34P" is visible in the bottom right corner. |
| 9864 | HTA5W | 73.03*98.43*13.08 |  A photograph showing the front view of a circular oil seal. It has a black inner lip, a greyish-brown outer ring, and a red base. The seal is resting on a white surface with red text that reads "OIL SEALS WLK". A timestamp "20 3:27PM" is visible in the bottom right corner. |  A photograph showing the back view of the same oil seal. It features a black inner lip, a greyish-brown outer ring, and a red base. The seal is resting on a white surface with red text that reads "OIL SEALS WLK". A timestamp "20 3:27PM" is visible in the bottom right corner. |







| CODE | TYPE | SIZE | PHOTO FRONT | PHOTO BACK |
|-------|--------|---|--|---|
| 14002 | TB5Y | 35.53*58.17/63.91*12.7 |  A black oil seal with a green outer ring. The inner lip is visible. The text 'WLK OIL SEAL' is printed in red on the inner surface. A timestamp '20 4:00PM' is visible in the bottom right corner. |  A black oil seal with a green outer ring. The inner lip is visible. The text 'WLK OIL SEAL' is printed in red on the inner surface. A timestamp '20 4:0' is visible in the bottom right corner. |
| 15186 | HTB5L | 38.1*60.37/65.48*12.29 |  A black oil seal with a yellow-green outer ring. The inner lip is visible. The text 'WLK OIL SEAL' is printed in red on the inner surface. A timestamp '20 3:50PM' is visible in the bottom right corner. |  A black oil seal with a blue outer ring. The inner lip is visible. The text 'WLK OIL SEAL' is printed in red on the inner surface. A timestamp '20 3:50PM' is visible in the bottom right corner. |
| 16725 | HTB59L | 42.88*63.55/73.03*9.98/21.21 Blue Painting |  A black oil seal with a blue outer ring. The inner lip is visible. The text 'WLK OIL SEAL' is printed in red on the inner surface. A timestamp '21 1:17PM' is visible in the bottom right corner. |  A black oil seal with a blue outer ring. The inner lip is visible. The text 'WLK OIL SEAL' is printed in red on the inner surface. A timestamp '21 1:18PM' is visible in the bottom right corner. |

| CODE | TYPE | SIZE | PHOTO FRONT | PHOTO BACK |
|-------|------|-------------------------------------|--|---|
| 38776 | Y | 98.43*144.53*22.23 370023A |  |  |
| 47697 | Y | 121.06*160.3*15.47/28.58 370003A |  |  |
| 51098 | SBP | 38.1*63.55*11.10 |  |  |







| CODE | TYPE | SIZE | PHOTO FRONT | PHOTO BACK |
|--------|---------|------------------------------|---|---|
| 417492 | TA | 87.30*114.33*9.53 |  <p>A photograph showing the front view of a circular oil seal. The seal has a black rubber lip and a metal housing with a red-painted outer edge. It is placed on a white background with red text that reads 'WLK OIL SEALS'.</p> |  <p>A photograph showing the back view of the same oil seal. The metal housing is visible, showing a black inner ring and a red-painted outer ring. The background has red text 'WLK OIL SEALS'.</p> |
| 13685 | HTB59LY | 34.93*57.15/63.5*11.13/22.63 |  <p>A photograph showing the front view of a smaller oil seal. It features a black rubber lip and a metal housing with a red-painted outer edge. The background has red text 'WLK OIL SEALS'.</p> |  <p>A photograph showing the back view of the oil seal. The metal housing is visible, showing a black inner ring and a red-painted outer ring. The background has red text 'WLK OIL SEALS'.</p> |
| 13735 | TB5Y | 35*57/64*9.7/16 |  <p>A photograph showing the front view of an oil seal. It has a black rubber lip and a metal housing with a red-painted outer edge. The background has red text 'WLK OIL SEALS'.</p> |  <p>A photograph showing the back view of the oil seal. The metal housing is visible, showing a black inner ring and a red-painted outer ring. The background has red text 'WLK OIL SEALS'.</p> |







| CODE | TYPE | SIZE | PHOTO FRONT | PHOTO BACK |
|-------|--------|---|--|---|
| 13750 | HTA5 | 34.93*54.91/61*9.12/14.68 Green Painting |  |  |
| 13757 | HTBG59 | 35*58/67*11/19 |  |  |
| 13978 | HTC9R | 35*67*12/18 |  |  |





| CODE | TYPE | SIZE | PHOTO FRONT | PHOTO BACK |
|-------|-------|--|---|--|
| 13995 | DB5 | 35.53*58.22/69.85*13.89 W/sealant on OD |  A black oil seal with a red sealant band on the outer diameter. The seal is shown from a front perspective, revealing the inner lip and the outer ring. A timestamp '13 2:36PM' is visible in the bottom right corner. |  A black oil seal with a red sealant band on the outer diameter. The seal is shown from a back perspective, highlighting the outer ring and the sealant. A timestamp '13 2:36PM' is visible in the bottom right corner. |
| 14007 | TB59Y | 35*56/63.6*16 VITON BROWN |  A brown Viton oil seal. The seal is shown from a front perspective, showing the inner lip and the outer ring. A timestamp '11 10:16AM' is visible in the bottom right corner. |  A brown Viton oil seal. The seal is shown from a back perspective, showing the outer ring and the sealant. A timestamp '11 10:16AM' is visible in the bottom right corner. |
| 14234 | HTG9L | 38*54*12.5/27.5 |  A black oil seal with a threaded outer ring. The seal is shown from a front perspective, showing the inner lip and the outer ring. A timestamp '13 2:44PM' is visible in the bottom right corner. |  A black oil seal with a threaded outer ring. The seal is shown from a back perspective, showing the outer ring and the sealant. A timestamp '13 2:44PM' is visible in the bottom right corner. |





| CODE | TYPE | SIZE | PHOTO FRONT | PHOTO BACK |
|-------|-------|---|--|---|
| 14393 | TB59Y | 35.53*63.09/67.87*8.14/13.08 Brown NBR, Green Painting |  A photograph showing the front view of a green-painted oil seal with a brown NBR lip. The seal is resting on a white surface with red text that includes 'K OIL SEALS'. A timestamp '11 10:05AM' is visible in the bottom right corner. |  A photograph showing the back view of the same green-painted oil seal. The red text 'LK OIL SEALS' is visible on the white surface. A timestamp '11 10:03AM' is visible in the bottom right corner. |
| 14762 | TC9 | 40*72*11/18 |  A photograph showing the front view of a black oil seal. The seal is resting on a white surface with red text that includes 'SEALS WLK'. A timestamp '14 3:48PM' is visible in the bottom right corner. |  A photograph showing the back view of the same black oil seal. The red text 'SEALS WLK' is visible on the white surface. A timestamp '14 3:49PM' is visible in the bottom right corner. |
| 14790 | TBC5 | 38*51/58*13/15 |  A photograph showing the front view of a black oil seal with a yellow-green lip. The seal is resting on a white surface with red text that includes 'SEALS'. A timestamp '11 10:43AM' is visible in the bottom right corner. |  A photograph showing the back view of the same black oil seal with a yellow-green lip. The red text 'SEALS' is visible on the white surface. A timestamp '11 10:4' is visible in the bottom right corner. |

| CODE | TYPE | SIZE | PHOTO FRONT | PHOTO BACK |
|--------|--------|---|--|--|
| 14978 | HTB59L | 38.1*60.35/67.27*11.68/18.06 Blue Painting |  A photograph showing the front view of a blue-painted oil seal. It features a black outer ring and a green inner ring. The seal is placed on a white surface with red text that includes 'WLK' and 'OIL SEALS'. A red timestamp '20 10:10AM' is visible in the bottom right corner. |  A photograph showing the back view of the same blue-painted oil seal. It shows the internal components, including a black O-ring and a green inner ring. The seal is on a white surface with red text including 'WLK' and 'OIL SEALS'. A red timestamp '20 10:09AM' is visible in the bottom right corner. |
| 15015 | TBAY | 38.1*60.33*11.91/16.66 |  A photograph showing the front view of a dark grey/black oil seal. It has a thick, cylindrical shape. The seal is on a white surface with red text including 'WLK' and 'OIL SEALS'. A red timestamp '21 1:...' is visible in the bottom right corner. |  A photograph showing the back view of the dark grey/black oil seal. It shows the internal O-ring and the inner structure. The seal is on a white surface with red text including 'WLK' and 'OIL SEALS'. A red timestamp '21 1:...' is visible in the bottom right corner. |
| 15305P | TBC5 | 38.71*67.52/75.01*15.7 Blue Painting |  A photograph showing the front view of a blue-painted oil seal. It has a black outer ring and a green inner ring. The seal is on a white surface with red text including 'WLK' and 'OIL SEALS'. A red timestamp '11 9:34AM' is visible in the bottom right corner. |  A photograph showing the back view of the blue-painted oil seal. It shows the internal components, including a black O-ring and a green inner ring. The seal is on a white surface with red text including 'WLK' and 'OIL SEALS'. A red timestamp '11 9:26AM' is visible in the bottom right corner. |





| CODE | TYPE | SIZE | PHOTO FRONT | PHOTO BACK |
|-------|-------|---|--|---|
| 15306 | HTB5L | 38.71*67.46/76.2*10.77 Blue Painting |  |  |
| 15310 | TC9 | 39*57*11/17 |  |  |
| 15372 | TC9 | 39*59*11/17 |  |  |





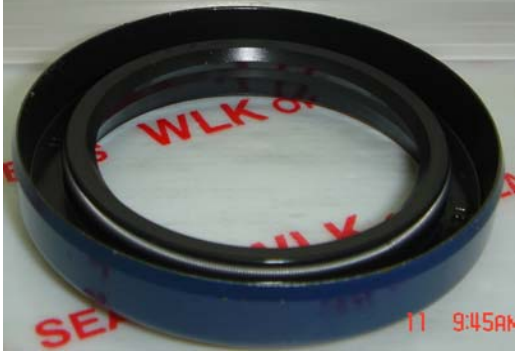

| CODE | TYPE | SIZE | PHOTO FRONT | PHOTO BACK |
|-------|---------|-------------------------|--|---|
| 15440 | TC9 | 39.42*62.15*12.7/16.66 |  |  |
| 15502 | HTB5W | 39.42*69.85*6.76/15.09 |  |  |
| 15629 | HTBC59Y | 39.29*62.12/68*11/14.68 |  |  |







| CODE | TYPE | SIZE | PHOTO FRONT | PHOTO BACK |
|--------|------|--------------------------------------|--|---|
| 15716 | HTA5 | 39.70*55.17/62.12*13.11 Red Painting |  |  |
| 15746 | KB59 | 40*55/65*8.2 Green Painting |  |  |
| 15750N | TB5 | 40.01*58.17/64.10*9.14 Blue Painting |  |  |





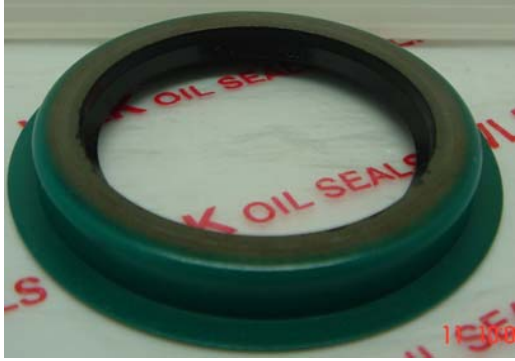

| CODE | TYPE | SIZE | PHOTO FRONT | PHOTO BACK |
|-------|--------|--|--|---|
| 15788 | TB59Y | 39.42*80.26/70.5*6.76/16.89 W/sealant |  |  |
| 15791 | TBA59Y | 39.42*80.26/71.04*13.46/16.6 6 |  |  |
| 15805 | TG35 | 40*52/58*7.6 NBR BROWN COLOR |  |  |





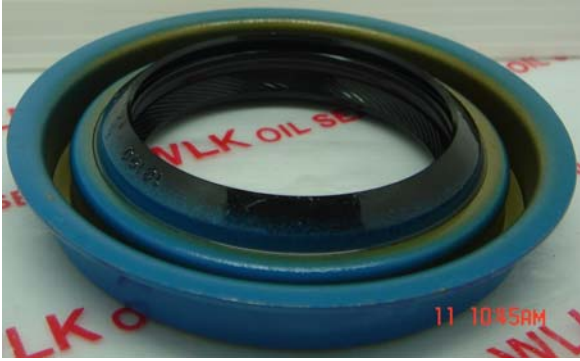

| CODE | TYPE | SIZE | PHOTO FRONT | PHOTO BACK |
|-------|-------|---------------|---|---|
| 15849 | TB9 | 40*64*12/17.5 |  A black oil seal with a double-lip design. The inner lip is wider and has a beveled edge. The outer lip is narrower. It is shown against a white background with red text. |  The back view of the oil seal 15849, showing the outer lip and the inner lip from the opposite side. The red text 'K OIL S' is visible on the white background. |
| 15882 | HTC9L | 40*75*12/19 |  A black oil seal with a double-lip design. The inner lip is wider and has a beveled edge. The outer lip is narrower. It is shown against a white background with red text. |  The back view of the oil seal 15882, showing the outer lip and the inner lip from the opposite side. The red text 'K OIL SEALS' is visible on the white background. |
| 15887 | TCY | 40*56/65*20 |  A black oil seal with a double-lip design. The inner lip is wider and has a beveled edge. The outer lip is narrower. It is shown against a white background with red text. |  The back view of the oil seal 15887, showing the outer lip and the inner lip from the opposite side. The red text 'K OIL S' is visible on the white background. |







| CODE | TYPE | SIZE | PHOTO FRONT | PHOTO BACK |
|-------|--------|---------------------------------------|---|--|
| 16015 | TB9Y | 41*58*9/12.7 |  <p>Front view of oil seal 16015, showing a blue outer ring and a black inner ring. The seal is placed on a white surface with red text 'WLK OIL SEALS' and a timestamp '11 9:41'.</p> |  <p>Back view of oil seal 16015, showing the blue outer ring and black inner ring. The seal is placed on a white surface with red text 'WLK OIL SEALS' and a timestamp '11 9:45AM'.</p> |
| 16805 | HTB5R | 42.88*66.62/80.16*13.46 Blue Painting |  <p>Front view of oil seal 16805, showing a blue outer ring with yellow-green inner rings. The seal is placed on a white surface with red text 'WLK OIL SEALS' and a timestamp '11 9:53AM'.</p> |  <p>Back view of oil seal 16805, showing the blue outer ring and yellow-green inner rings. The seal is placed on a white surface with red text 'WLK OIL SEALS' and a timestamp '11 9:52'.</p> |
| 17005 | HTB59Y | 42.88*78.3/83*11.91/13.75 |  <p>Front view of oil seal 17005, showing a green outer ring with yellow-green inner rings. The seal is placed on a white surface with red text 'WLK OIL SEALS' and a timestamp '11 10:08AM'.</p> |  <p>Back view of oil seal 17005, showing the green outer ring and yellow-green inner rings. The seal is placed on a white surface with red text 'WLK OIL SEALS' and a timestamp '11 10:07'.</p> |







| CODE | TYPE | SIZE | PHOTO FRONT | PHOTO BACK |
|-------|-------|--|--|--|
| 17037 | TB5 | 42.88*78.63/87.91*13.89 Blue Painting |  A photograph showing the front view of a blue-painted oil seal. The seal has a black rubber lip and a metal housing. The text 'WLK OIL SEALS' is visible in red on the white background behind the seal. A timestamp '11 9:58AM' is in the bottom right corner. |  A photograph showing the back view of the same blue-painted oil seal. The text 'WLK OIL SEALS' is visible in red on the white background. A timestamp '11 9:58AM' is in the bottom right corner. |
| 17190 | HTB5R | 44.17*71.42/83.06*8.31/15.06 Blue Painting |  A photograph showing the front view of a blue-painted oil seal with a yellow-green lip. The text '#17190' is in the top left corner. The text 'WLK OIL SEALS' is visible in red on the white background. A timestamp '09 3:53PM' is in the bottom right corner. |  A photograph showing the back view of the same blue-painted oil seal with a yellow-green lip. The text 'WLK OIL SEALS' is visible in red on the white background. A timestamp '09 3:52PM' is in the bottom right corner. |
| 17458 | HSB5R | 44.37*66.62/72.82*9.27 Green Painting |  A photograph showing the front view of a green-painted oil seal. The seal has a black rubber lip and a metal housing. The text 'WLK OIL SEALS' is visible in red on the white background. A timestamp '11 10:02AM' is in the bottom right corner. |  A photograph showing the back view of the same green-painted oil seal. The text 'WLK OIL SEALS' is visible in red on the white background. A timestamp '11 10:01AM' is in the bottom right corner. |

| CODE | TYPE | SIZE | PHOTO FRONT | PHOTO BACK |
|-------|-------|---|--|---|
| 17787 | HTB5R | 44.96*63.5/77.39*10.85 silicon, Green Painting |  A photograph showing the front view of a circular oil seal. It features a grey outer ring and a red inner ring. The seal is placed on a white surface with red text that reads "WLK OIL SEALS". A timestamp "11 9:51 AM" is visible in the bottom right corner. |  A photograph showing the back view of the same oil seal. It features a green outer ring and a red inner ring. The seal is placed on a white surface with red text that reads "WLK OIL SEALS". A timestamp "11 9:51" is visible in the bottom right corner. |
| 17815 | VB5 | 44.04*59.13/66.8*7.95 |  A photograph showing the front view of a circular oil seal. It features a grey outer ring and a green inner ring. The seal is placed on a white surface with red text that reads "WLK OIL SEALS". A timestamp "11 9:51" is visible in the bottom right corner. |  A photograph showing the back view of the same oil seal. It features a grey outer ring and a green inner ring. The seal is placed on a white surface with red text that reads "WLK OIL SEALS". A timestamp "11 9:51" is visible in the bottom right corner. |
| 18009 | KB59 | 45.95*59.97/72.82*9.53 |  A photograph showing the front view of a circular oil seal. It features a yellow-green outer ring and a black inner ring. The seal is placed on a white surface with red text that reads "WLK OIL SEALS". A timestamp "13 2:43 PM" is visible in the bottom right corner. |  A photograph showing the back view of the same oil seal. It features a blue outer ring and a black inner ring. The seal is placed on a white surface with red text that reads "WLK OIL SEALS". A timestamp "13 2:42" is visible in the bottom right corner. |

| CODE | TYPE | SIZE | PHOTO FRONT | PHOTO BACK |
|-------|--------|---|--|---|
| 18024 | TB59Y | 46.05*78.54/86.92*12.7/15.47 W/sealant |  A photograph showing the front view of a yellow-green oil seal with a black inner ring. The seal is placed on a white surface with red text. A timestamp '11 9:42AM' is visible in the bottom right corner. |  A photograph showing the back view of the same yellow-green oil seal. The black inner ring is clearly visible. A timestamp '11 9:41AM' is visible in the bottom right corner. |
| 18190 | HTB5R | 46.05*70.64/78.97*11.51/13.8 9 Blue Painting |  A photograph showing the front view of a blue oil seal with a black inner ring. The seal is placed on a white surface with red text. A timestamp '11 10:45AM' is visible in the bottom right corner. |  A photograph showing the back view of the same blue oil seal. The black inner ring is clearly visible. A timestamp '11 10:44' is visible in the bottom right corner. |
| 18999 | HTB5LR | 47.88*68.58/76.2*14.89 |  A photograph showing the front view of a green oil seal with a black inner ring. The seal is placed on a white surface with red text. A timestamp '20 4:03PM' is visible in the bottom right corner. |  A photograph showing the back view of the same green oil seal. The black inner ring is clearly visible. A timestamp '20 4:02PM' is visible in the bottom right corner. |

| CODE | TYPE | SIZE | PHOTO FRONT | PHOTO BACK |
|-------|------|---|--|---|
| 19753 | VBP | 50.8*65.07*5.94 Green Painting NBR80 |  |  |
| 24670 | UM | 62.84*90.02*7.24 |  |  |
| 27292 | HSGL | 69.85*89.99*10.31 |  |  |

| CODE | TYPE | SIZE | PHOTO FRONT | PHOTO BACK |
|--------|------|-------------------------|---|--|
| 560361 | KB9 | 45*54*5.7/9 |  A black oil seal with a yellowish-green outer ring, shown from a top-down perspective. The seal is placed on a white surface with red text that reads "OIL SEALS" and "WL". A red timestamp "11 10:4" is visible in the bottom right corner. |  A black oil seal with a yellowish-green outer ring, shown from a top-down perspective. The seal is placed on a white surface with red text that reads "OIL SEALS" and "WL". A red timestamp "11 10:46A" is visible in the bottom right corner. |
| 6808N | TB5 | 47.63*71.04/80.26*14.27 |  A black oil seal with a yellowish-green outer ring and a red inner ring, shown from a top-down perspective. The seal is placed on a white surface with red text that reads "OIL SEALS" and "WL". A red timestamp "20 3:3" is visible in the bottom right corner. |  A black oil seal with a yellowish-green outer ring and a red inner ring, shown from a top-down perspective. The seal is placed on a white surface with red text that reads "OIL SEALS" and "WL". A red timestamp "20" is visible in the bottom right corner. |
| 99044 | RGA | 39.29*53.57*8.33/23.42 |  A black oil seal with a flared top and a threaded bottom, shown from a top-down perspective. The seal is placed on a white surface with red text that reads "OIL SEALS" and "WL". A red timestamp "11" is visible in the bottom right corner. |  A black oil seal with a flared top and a threaded bottom, shown from a top-down perspective. The seal is placed on a white surface with red text that reads "OIL SEALS" and "WL". A red timestamp "11 10:46A" is visible in the bottom right corner. |

| CODE | TYPE | SIZE | PHOTO FRONT | PHOTO BACK |
|------|---------|--------------------------------|--|---|
| 9934 | SBP | 25.4*41.25*6.35 Green Painting |  |  |
| | HTB59RY | 48*71/80.2*14/20.5 |  |  |
| KB5Y | | 50.8*63.09/69.85*5.59/6.45 |  |  |

USO AGRÍCOLA



| BRAND | MODEL | 用處 | APPLICATION | Part No. | Oil Seals Size |
|---------------|-------------------|-------------|--|----------|----------------|
| CARRARO 三馬 | | 體 | Rear Wheel(Outer) | | 75*110*12/16.5 |
| CARRARO 三馬 | 61000/71000/81000 | 前輪,原車襯套不用拆 | Front Wheel | 5126465 | 130*160*15/16 |
| CARRARO 三馬 | 61000/71000/81000 | 後輪(內) | Rear Wheel(Inner) | | 60*100*13 |
| CHII FA 兩和 | CF168單輪 | | | | 13*22*5 |
| CHII FA 兩和 | CF168單輪 | | | | 21*31*7 |
| CHII FA 兩和 | CF168單輪 | | | | 25*35*5 |
| CHII FA 兩和 | CF168單輪 | | | | P10 |
| CHII FA 兩和 | CF168單輪 | | | | P15 |
| CHII FA 兩和 | CF168單輪 | | | | P17 |
| CHII FA 兩和 | CF168單輪 | | | | P20 |
| CHII FA 兩和 | CF168單輪 | | | | 封閉墊圈8MM |
| CHII FA 兩和 | CF168單輪 | 尾輪 | Idler | | 15*35*4 |
| CHII FA 兩和 | CF168單輪 | 耕耘軸 | Rotary | | 20*47*12/14 |
| CHII FA 兩和 | CF168單輪 | 輪軸 | Wheel Shaft | | 25*52*12 |
| CHII FA 兩和 | CF670雙輪 | 耕耘部鍊條箱 | Rotary System Chain Case | | 20*42*8 |
| CHII FA 兩和 | CF670雙輪 | 耕耘部鍊條箱 | Rotary System Chain Box | | 10*18.5*2 |
| CHII FA 兩和 | CF670雙輪 | 耕耘部鍊條箱 | Rotary System Chain Box | | 12.3*22*2/3 |
| CHII FA 兩和 | CF670雙輪 | 耕耘部鍊條箱 | Rotary System Chain Box | | 8*18.2*2 |
| CHII FA 兩和 | CF670雙輪 | 耕耘部鍊條箱 | Rotary System Chain Box | | P10 |
| CHII FA 兩和 | CF670雙輪 | 耕耘部鍊條箱 | Rotary System Chain Box | | P10 |
| CHII FA 兩和 | CF670雙輪 | 耕耘部鍊條箱 | Rotary System Chain Box | | P8 |
| CHII FA 兩和 | CF670雙輪 | 耕耘部鍊條箱(耕耘軸) | Rotary System Chain Case (Rotary) | | 30*55*8/15 |
| CHII FA 兩和 | CF670雙輪 | 齒輪變速箱 | Gear Speed Changing Case | | 12*22*7 |
| CHII FA 兩和 | CF670雙輪 | 齒輪變速箱 | Gear Speed Changing Box | | 10*18.5*2 |
| CHII FA 兩和 | CF670雙輪 | 齒輪變速箱 | Gear Speed Changing Box | | 38*10 |
| CHII FA 兩和 | CF670雙輪 | 齒輪變速箱 | Gear Speed Changing Box | | P10 |
| CHII FA 兩和 | CF670雙輪 | 齒輪變速箱 | Gear Speed Changing Box | | P20 |
| CHII FA 兩和 | CF670雙輪 | 齒輪變速箱(輪軸) | Gear Speed Changing Case (Wheel Shaft) | | 40*60*12 |
| DA DI LIN 大地菱 | 2850 | 六齒車心 | Transmission Shaft 6T | | 40*62/72*13.5 |
| DA DI LIN 大地菱 | 2850 | 六齒車心 | Transmission Shaft 6T | | 30*40*21 |
| DA DI LIN 大地菱 | 2850 | 離合器傳動軸 | ClutchTransmission Shaft | | 45*62*9 |
| DA DI LIN 大地菱 | 2850 | 鏈仔輪 | Chain Wheel | | 40*7 |
| DA DI LIN 大地菱 | TPA3252 | | | | 62/72*10 |
| DA DI LIN 大地菱 | TPH 3252/2850 | 六齒車心 合體 | Transmission Shaft 6T | | 40*62/72*13.5 |
| DA DI LIN 大地菱 | TPH 3252/2850 | 六齒車心 合體 | Transmission Shaft 6T | | 30*40*18 |
| DA DI LIN 大地菱 | TPH 3252/2850 | 曲軸 | Crank Shaft | | 70*90*12 |

WLK Agriculture Machine Used Products.

DATE : 2014/01/03

| BRAND | MODEL | 用處 | APPLICATION | Part No. | Oil Seals Size |
|---------------|-------------------------------------|---------------------|-----------------------------------|-----------|-----------------|
| DA DI LIN 大地菱 | TPH 3252/2850 | 尾輪 | Idler | | 25*62*11/16 |
| DA DI LIN 大地菱 | TPH 3252/2850 | 尾輪 | Idler | BQ1577E | 25*62*10.5/17 |
| DA DI LIN 大地菱 | TPH 3252/2850 | 尾輪 合體 | Idler | | 35*62*7/13 |
| DA DI LIN 大地菱 | TPH 3252/2850 | 尾輪 合體 | Idler | | 25*35*16 |
| DA DI LIN 大地菱 | TPH 3252/2850 | 尾輪 合體 | Idler | | 35*52*12 |
| DA DI LIN 大地菱 | TPH 3252/2850 | 尾輪 合體 | Idler | | 25*35*18 |
| DA DI LIN 大地菱 | TPH 3252/2850 | 車心新型 | Transmission Shaft new Type | | 30*62*12/18 |
| DA DI LIN 大地菱 | TPH 3252/2850 | 滾輪 | Track Roller | BQ4096E | 25*52*11/18 |
| DA DI LIN 大地菱 | TPH 3252/2850 | 滾輪 中輪 | Track Roller | | 25*52*12 |
| DA DI LIN 大地菱 | 搬運車(4WD) | 前輪轉向節 | Front Wheel Steering Section | | 50*72*12 |
| FIAT | | 曲軸 CS (S) | Crank Shaft CS (S) | →40101341 | 114*135*13 |
| FIAT | (60-90) | 後輪 | Rear Wheel | | 85*110*12/18 |
| FIAT | | | Front Wheel Transmission Shaft | | 42*62*10 |
| FIAT | 100.115.50° | 前輪傳動軸 | Auxiliary Oil Seals | | 50*65*10 |
| FIAT | 100-110 | 補助油封 | Front Wheel | | 165*190*15/21 |
| FIAT | 100-90 | 前輪 | Front Wheel Transmission Shaft | | 55*90*10 |
| FIAT | 100-90 | 前輪傳動軸 | Front Wheel (New Type) | 5137109 | 165*190*15/21 |
| FIAT | 100-90DT | 前輪(新型) | Front Wheel Shaft | | 40*62*5 |
| FIAT | 100-90DT | 前輪軸 | Front Wheel Shaft | | 40*62*9 |
| FIAT | 100HP/110HP/130/140/ 160 | 車尾 PTO (S)內 | PTO (S) Inner | 5105891 | 68*90*10 |
| FIAT | 100HP/160HP/140HP/1 30HP | 前輪(油封厚度須修 短 4MM) | width shorter for 4MM) | AQ3074E | 55*85*13/19 |
| FIAT | 110HP | 前輪 | Front Wheel | 5136003 | 110*130*15/16 |
| FIAT | 130 HP/140/160 | 後輪 | Rear Wheel | 5126465 | 130*160*15/16 |
| FIAT | 130HP | 車尾 PTO (S) | PTO (S) | 5105891 | 68*90*10 |
| FIAT | 130HP/140HP/160HP | 前輪 | Front Wheel | | 189*220*15/26 |
| FIAT | 140HP 160HP | 改前輪 | Revised Front Wheel | | 55*85*12 |
| FIAT | 60/65/45DT | 前輪軸 | Front Wheel Shaft | | 30*42*7 |
| FIAT | | | Front Wheel Transmission Shaft | | 30*72*10 |
| FIAT | 60DT/65DT/45DT(4WD) /65-90/80-76 | 前輪 FW (S) | Front Wheel FW (S) | 5135387 | 90*120*13 |
| FIAT | 65-90 | 傳動PTO改裝用 | Transmission PTO Revised | AQ3020P | 54*80*13.5/15.8 |
| FIAT | 65-90DT | 改前輪接頭 | Revised Front Wheel Connector | | 85*110*12/18 |
| FIAT | 80 HP (4WD) | 前輪110HP | Front Wheel 110HP | | 165*190*15/21 |
| FIAT | 80 HP(80-90) | 車尾 PTO (S) | PTO (S) | 5119203 | 55*80*10 |
| FIAT | 80/65/45HP/85HP/60HP | 感應桿 | Sensor Rod | | 24.3*37.35*9 |
| FIAT | 80-90 | 傳動PTO改裝用 | Transmission PTO Revised | | 54*80*13.5/15.8 |
| FIAT | 8606 | 耕耘軸小 | Rotary Small | | 55*82*10.5/17 |
| FIAT | EX2500 | | | | 45*62*9 |
| FORD | | 迴轉台 | Rotation Base | | 17.5*28.5*8 |
| FORD | | 迴轉台 | Rotation Base | | 24*34.2*6.5 |
| FORD | | 迴轉台 | Rotation Base | | 58.72*79.37*9.5 |
| FORD | | 煞車 | Brake | | PL11 |
| FORD | 7610 / 6610 | 前輪(改裝) | Front Wheel (Alternated) | | 52*75*16 |
| HINOMOTO | | | | | 35*52*9 |
| HINOMOTO | 1600 | 尾輪 | Idler | | 35*47*7 |
| HINOMOTO | 1600 | 尾輪 | Idler | | 25*35*18 |
| HINOMOTO | 1600 | 前輪 | Front Wheel | | P 168 * 2 |

WLK Agriculture Machine Used Products.

DATE : 2014/01/03

| BRAND | MODEL | 用處 | APPLICATION | Part No. | Oil Seals Size |
|----------|-------------------|-------------------|----------------------------------|---------------|-----------------|
| HINOMOTO | 1600 | 前擔輪 | Front Wheel | | 30*52*9.5/12 |
| HINOMOTO | 1600/2100 | 後輪/E410耕耘軸 大,強 | Rear Wheel/E410Rotary Big | AQ2671E | 45*68*11/17 |
| HINOMOTO | 203 | | | | 170*186*7.5/10 |
| HINOMOTO | 2304 | 後輪 | Rear Wheel | | 50*90*12/21 |
| HINOMOTO | 2304 | 耕耘軸大 | Rotary Big | AQ2407E | 40*65*11/18 |
| HINOMOTO | 2304 | 傳動 PTO | Transmission PTO | SL35,40/49,18 | 35*60*12/18 |
| HINOMOTO | 2800D | 尾輪 | Idler | | 35*47*7 |
| HINOMOTO | 2800D | 尾輪 | Idler | | 25*35*18 |
| HINOMOTO | 2800D | 前輪 | Front Wheel | AQ8313P | 35*62*13/15.5 |
| HINOMOTO | 2800D | 前輪(有珠式)大黃 消 | Front Wheel (Bearing) Bearing | | 150*170 |
| HINOMOTO | 2800D | 前擔轉輪 | Front Shift Wheel | AE8190E | 170*186*7.5/10 |
| HINOMOTO | 2800D | 前擔轉輪 | Front Shift Wheel | | P 160 * 2 |
| HINOMOTO | 2800D | 後傳動 PTO | Rear Transmission PTO | | 35*72/80*13 |
| HINOMOTO | 2800D | 耕耘軸 | Rotary | | 40*65*11/18 |
| HINOMOTO | 2800D | 耕耘軸小 | Rotary Small | AQ2110E | 35*60*12/18 |
| HINOMOTO | 2800D | 傳動 PTO | Transmission PTO | | 35*62*13/15.5 |
| HINOMOTO | 2800D(28HP) | 前輪下面 | Front Wheel Lower | | 20*30*7 |
| HINOMOTO | 322 | 傳動 PTO | Transmission PTO | | 35*62*13/18 |
| HINOMOTO | E1500D | | | | 39/46*10 |
| HINOMOTO | E1500D | 前輪 | Front Wheel | AQ8181P | 45*85*15.5/18.5 |
| HINOMOTO | E1500D | 前擔輪 | Front Shift Wheel | | 30*52*9.5/12 |
| HINOMOTO | E1500D | 前擔轉輪 | Front Shift Wheel | | 170*186*7.5/10 |
| HINOMOTO | E1500D | 前擔轉輪 | Front Shift Wheel | | P 168 * 2 |
| HINOMOTO | E1500D | 耕耘軸大 | Rotary Big | | 30*55*11.5/19 |
| HINOMOTO | E322 | 前擔轉輪 | Front Shift Wheel | | P 190 * 2 |
| HINOMOTO | E322 | 後輪 | Rear Wheel | AQ8166P | 50*90*12/21 |
| HINOMOTO | E322 | 後輪煞車軸 | Rear Wheel Brake Shaft | AE2359L | 40*55*8 |
| HINOMOTO | E322 | 耕耘軸大 | Rotary Big | AQ2671E | 45*68*11/17 |
| HINOMOTO | E322 | 耕耘軸大,小 | Rotary Big, Small | AQ2881E | 50*78*10/17 |
| HINOMOTO | E322 E522 | 前輪 (有珠型) | (Bearing) | | 166MM小型,新型*190 |
| HINOMOTO | E322 E522 | 前擔轉輪 | Front Shift Wheel | | 190*206*9.2 |
| HINOMOTO | E410 | 前輪 | Front Wheel | | 45*70*12 |
| HINOMOTO | E410 | 前輪站軸 | Front Wheel Vertical Shaft | AE8288P | 190*209*9.2 |
| HINOMOTO | E410 | 軸 | Shaft | AP8096E | 19*32*7 |
| HINOMOTO | E410(41HP) | 把手 | Handle | | 19*32*7 |
| HINOMOTO | E410(41HP) | 前輪 | Front Wheel | AQ8305P | 45*70*12/17 |
| HINOMOTO | E410(41HP) | 前輪 | Front Wheel | | 39/46*10 |
| HINOMOTO | E410(41HP) | 前擔轉輪 | Front Shift Wheel | AE8288P | 190*206*9.2 |
| HINOMOTO | E410(41HP) | 前擔轉輪 | Front Shift Wheel | | P 190 * 2 |
| HINOMOTO | E410(41HP) | 後傳動 PTO | Rear Transmission PTO | | 35*72/80*13 |
| HINOMOTO | E410(41HP) | 後輪 | Rear Wheel | AQ8890P | 60*110*12.5/21 |
| HINOMOTO | E410(41HP) | 耕耘軸大 | Rotary Big | AQ2671E | 45*68*11/17 |
| HINOMOTO | E410(41HP) | 耕耘軸小 | Rotary Small | AQ2110E | 35*60*12/18 |
| HINOMOTO | E410(41HP) | 傳動 PTO出力軸 | Transmission PTO Output Shaft | AQ8168P | 35*62*13/18 |
| HINOMOTO | E410(41HP)/MF2204 | 前輪 | Front Wheel | | 166mm |
| HINOMOTO | E522 | 耕耘軸大 | Rotary Big | AQ3563E | 72*100*13/17 |
| HINOMOTO | E522 | 耕耘軸小 | Rotary Small | AQ7242E | 60*90*12/18 |
| HINOMOTO | TA 417 | 傳動 PTO 合體 | Transmission PTO | | 35*40*17 |
| HINOMOTO | TA 527 | 傳動 PTO 合體 | Transmission PTO | | 40*72*12 |
| ISEKI | | | | | 8*18/26*16.5 |

WLK Agriculture Machine Used Products.

DATE : 2014/01/03

| BRAND | MODEL | 用處 | APPLICATION | Part No. | Oil Seals Size |
|-------|----------------|----------------------|---|---------------|--------------------|
| ISEKI | | | | | 16*28*6 |
| ISEKI | | | | | 20*35*10 |
| ISEKI | | | | V74212-238060 | 22*38*6 |
| ISEKI | | | | V74412-538070 | 25*38*7 |
| ISEKI | | | | V74012-53808 | 25*38*8 |
| ISEKI | | | | V74412-545100 | 25*45*10 |
| ISEKI | | 13-32 播手防泥 | 13-32 Planting Arm Scraper | | 8*18*7 |
| ISEKI | | 13-4動力傳動部播手厚 | 13-4 Power Transmission System Planting Arm 厚 | | 14*30*13 |
| ISEKI | | 2-17 | 2-17 | V74211-730050 | 17*30*5 |
| ISEKI | | 2-4 | 2-4 | V74211-525040 | 15*25*4 |
| ISEKI | | 8-32 | 8-32 | | 12*25*5 |
| ISEKI | | 9-29 | 9-29 | | 17*30*8 |
| ISEKI | | 井關(插)迴轉箱 *AE1013A通用* | Rotation Case | AE1013J | 20*35*8 |
| ISEKI | | 防震 | Shock Absorbor | | 8*17*4.5 |
| ISEKI | | 秧盤 | | | 22*38*8 |
| ISEKI | | 插秧機(新) | Planter (New) | | 14*30*6 |
| ISEKI | | 播手防泥 | Planting Arm Scraper | | 8*18*5.7 |
| ISEKI | | 播手側面 傳動 | Planting Arm Side - Transmission | | 30*35*11 |
| ISEKI | 1000 | 曲軸 | Crank Shaft | | 35*55*8 |
| ISEKI | 1000 | 滾輪 | Track Roller | | 30*47*10 |
| ISEKI | 1000 | 滾輪 | Track Roller | | 25*30*14 |
| ISEKI | 1000 700 | 滾輪 | Track Roller | | 25*47*7 |
| ISEKI | 2000 | 滾輪 | Track Roller | | 30*42*8 |
| ISEKI | 287 | 前輪橫軸 | Front Wheel Horizontal Shaft | BQ3119E | 45*70*10 |
| ISEKI | 28HP/35 HP | 耕耘軸大 | Rotary Big | AQ3074E | 55*85*13/19 |
| ISEKI | 32 HP | 後輪 | Rear Wheel | | 60*100*14/26 |
| ISEKI | 3360 | 滾輪 | Track Roller | | 25*52*16 |
| ISEKI | 3365 | 七齒車軸 | 7T Axle | | 35*48*8 |
| ISEKI | 41 HP | 耕耘軸小 | Rotary Small | AQ2688E | 45*72*13/20 |
| ISEKI | 417 | 前輪 | Front Wheel | BQ3160E1 | 55*82*10 |
| ISEKI | 41HP | 耕耘軸小 | Rotary Small | AQ2685E | 45*72*13/20 |
| ISEKI | 41HP/45HP | 前輪 | Front Wheel | AQ2407E | 40*65*11/18 |
| ISEKI | 41HP/45HP | 後輪 | Rear Wheel | AE8876E | 90*160/170.5*20/21 |
| ISEKI | 4500(45 HP) | 傳動 PTO | Transmission PTO | TL4500 | 45*60*9 |
| ISEKI | 4500(45 HP) | 傳動 PTO | Transmission PTO | TL4100 | 35*45*17 |
| ISEKI | 45HP | 前輪站 | Front Wheel Vertical Shaft | | 62/72*10/13 |
| ISEKI | 45HP | 耕耘軸小 | Rotary Small | AQ2688E | 45*72*13/20 |
| ISEKI | 5000/7000 | 前輪 | Front Wheel | BQ1674E | 70*89*11/18 |
| ISEKI | 6010 | 前輪 | Front Wheel | BQ4059E | 80*110*12 |
| ISEKI | 6010 | 耕耘軸大// 6010大王消直座 | Rotary Big. 6010 Bearing Vertical Base | AQ8943E | 65*95*12 |
| ISEKI | 65 HP/(7000舊型) | 耕耘軸大/小 | Rotary Big/ Small | AQ7021E | 65*100*11/18 |
| ISEKI | 700 | | | | 25*35*7 |
| ISEKI | 700 | | | | 20*35*7 |
| ISEKI | 700 | | | | 20*35*8 |
| ISEKI | 700 | | | | 27*37*7 |
| ISEKI | 700 | | | | 27*37*5 |

WLK Agriculture Machine Used Products.

DATE : 2014/01/03

| BRAND | MODEL | 用處 | APPLICATION | Part No. | Oil Seals Size |
|-------|------------------|------------|---|-----------------|----------------|
| ISEKI | 700 | | | | 25*40*7 |
| ISEKI | 700 | | | | 17*40*8 |
| ISEKI | 700 | 滾輪 | Track Roller | | 30*40*5 |
| ISEKI | 9520 | 傳動 PTO | Transmission PTO | | 40*45*21 |
| ISEKI | HA50 | HST幫浦 | HST Hydraulic Pump | | 25*45*10 |
| ISEKI | HA50/HA50G/HA60G | 滾輪/尾輪 | Track Roller /Idler | AG2118E | 35*62*10 |
| ISEKI | HA50/HA50G炮管 | 滾輪 合體 | Track Roller | 3642-172-003-00 | 35*62*10 |
| ISEKI | HA50/HA60 | 滾輪/尾輪 | Track Roller /Idler | | 30*62*8/14.5 |
| ISEKI | HA60 | 滾輪 | Track Roller | | 36*62*11/14 |
| ISEKI | HA60/HA50 | | | | 20*30*12.6 |
| ISEKI | HA60/HA50 | | | 3621-170-003-00 | 20*30*12.6 |
| ISEKI | HA60/HA50 | | | | 30*35*13 |
| ISEKI | HA60/HA50 | ?動推桿 | Push Rod | | 28*40*8 |
| ISEKI | HA60/HA50 | 活動輪 | Equalizer | 3621-170-003-00 | 20*30*12.6 |
| ISEKI | HA60/HA50 | 浮動輪(上面) | Carry Roller (Upper) | 3740-124-003-00 | 30*47*10 |
| ISEKI | HA60/HA50 | 浮動輪張力臂上面 | Carry Roller Tension Arm Upper | | 30*52*10 |
| ISEKI | HA60/HA50 | 浮動輪張力臂上面 | Carry Roller Tension Arm Upper | 3740-123-005-00 | 25*30*14 |
| ISEKI | HA60/HA50 | 搖動推桿 | Push Rod | | 17*35*8 |
| ISEKI | HA60G(炮管) | (原裝型) 尾輪 " | Idler (Original) | 3642-172-004-00 | 30*35*13 |
| ISEKI | HL2500(25 HP) | 尾輪 | Idler | | 35*62*10 |
| ISEKI | HL2500(25 HP) | 尾輪 | IDLER | | 25*35*16 |
| ISEKI | HL2500(25 HP) | 尾輪 | IDLER | | 30*35*15 |
| ISEKI | HL2500(25 HP) | 起動車心 | Starting | | 30*42*8 |
| ISEKI | HL2500(25 HP) | 起動車心 | Starting | | 30*42*4.5 |
| ISEKI | HL2500(25 HP) | 滾輪 | Track Roller | | 30*52*11 |
| ISEKI | HL2500(25 HP) | 滾輪 | Track Roller | | 25*30*14 |
| ISEKI | HL3700/HL4500 | 七齒車心 | Transmission Shaft 7T | | 40*52*5 |
| ISEKI | HL3700/HL4500 | 七齒車心 | Transmission Shaft 7T | | 40*52*8 |
| ISEKI | HL3700/HL4500 | 脫谷車鏈齒輪 | Threshing input Shaft | | 25*35*7 |
| ISEKI | HL3700/HL4500 | 脫谷變速箱(皮帶輪) | Threshing Drum Speed Changing Case (Pulley) | | 25*45*10 |
| ISEKI | HL3700/HL4500 | 割刀軸心 | Reaping Shaft | | 25*47*6 |
| ISEKI | HL3700/HL4500 | 滾輪, 尾輪 | Track Roller , Idler | | 30*62*16/18 |
| ISEKI | HL3700/HL4500 | 滾輪和尾輪 | Track Roller & Idler | | 35*62*10 |
| ISEKI | HL3700/HL4500 | 導輪 | Carry Roller | | 20*28*11 |
| ISEKI | HL3700/HL4500 | 螺旋桿 | Scroll Rod | | 17*47*8 |
| ISEKI | HL3700/HL4500 | 螺旋桿接頭 | Scroll Rod Connector | | 20*32*8 |
| ISEKI | LX2000 | 耕耘軸小 | Rotary Small | | 55*82*10.5/17 |
| ISEKI | NIPP01 | 耕耘軸大 | Rotary Big | AQ8943E | 65*95*11/18 |
| ISEKI | PA | | | | 25*40*6/8 |
| ISEKI | PA | 播手防泥(有彈簧) | Planting Arm Scraper (W/spring) | | 8*18*17 |
| ISEKI | PA60 | 插植桿(怪手) | Planting Arm | | 15*35*8 |
| ISEKI | PA60(6種) | 送苗移動桿 | Feeding Rod | | 12*22*7 |
| ISEKI | PA60/PA600 | 插植手 | Planting Arm | | 15*30*8 |
| ISEKI | PA80/PA83 | 前輪站軸 | Front Wheel Vertical Shaft | | 30*50*8 |
| ISEKI | PA80/PA83 | 後輪軸 | Rear Wheel Shaft | AE2668A | 45*68*12 |

WLK Agriculture Machine Used Products.

DATE : 2014/01/03

| BRAND | MODEL | 用處 | APPLICATION | Part No. | Oil Seals Size |
|-------|--------------------|---------------|---------------------------------------|-----------------|--------------------|
| ISEKI | PA80/PA83 | 後輪軸(改裝型)原倉 | Rear Wheel Shaft(Revised Type) | | 45*68*11/17 |
| ISEKI | PA80/PA83 | 插植桿,插植臂上面(新型) | Planting Arm Upper (New) | 2142-736-236-00 | 12*17*11 |
| ISEKI | PA80/PA83 | 插植桿凸輪 | Planting Arm Cam | V740-115-240-70 | 15*24*7 |
| ISEKI | PA80/PA83 | 插植桿防泥 | Planting Arm Scraper | 2161-738-221-00 | 8*18/23*19 |
| ISEKI | PA80/PA83 | 播手 | Planting Arm | AE1013J | 20*35*5/7 |
| ISEKI | T10510 | 出力軸PTO | Output Shaft PTO | | 50*68*10 |
| ISEKI | T10510 | 傳動 PTO | Transmission PTO | (有兩種) | 45*68*12 |
| ISEKI | T5000 | 前輪站軸 | Front Wheel Vertical Shaft | | 70*89*11/18 |
| ISEKI | T5000/T 7000 | 傳動 PTO 合體 | Transmission PTO | | 45*58*8 |
| ISEKI | T5000/T6500 | 耕耘軸大 2米1 | Rotary Big 2.1M | AQ7021E | 65*100*11/18 |
| ISEKI | T7000 | 前站輪 | Front Vertical Wheel | | 100*125*8 |
| ISEKI | T7000 | 前站橫輪 | Front Vertical Shaft Horizontal Wheel | | 100*125*13 |
| ISEKI | T7000 | 前輪橫軸 (2WD) | Front Wheel Horizontal Shaft (2WD) | | 65*82*12 |
| ISEKI | T7000 | 前輪橫軸 (2WD) | Front Wheel Horizontal Shaft (2WD) | | 45*60*20 |
| ISEKI | T7000 | 耕耘軸小 | Rotary Small | AQ7021E | 65*100*11/18 |
| ISEKI | T9000 | 前輪 | Front Wheel | | 51.5*77*11 |
| ISEKI | T9000 | 耕耘軸大 | Rotary Big | | 75*110*23/25 |
| ISEKI | T9000 | 耕耘軸小 | Rotary Small | | 60*92*22 |
| ISEKI | T9000 | 傳動 PTO 合體 | Transmission PTO | | 40*45*21 |
| ISEKI | T9000/T7000 | 後輪 合體 | Rear Wheel | AE8876E | 90*160/170.5*20/21 |
| ISEKI | T9000/T7000 | 後輪 合體 | Rear Wheel | | 75*90*21 |
| ISEKI | TA287(28HP) | 前輪 | Front Wheel | AQ2110E | 35*60*12/18 |
| ISEKI | TA287(28HP) | 後輪(牛腳) | Rear Wheel | | 60*100*14/26 |
| ISEKI | TA287(28HP) | 耕耘軸大 | Rotary Big | AQ3074E | 55*85*13/19 |
| ISEKI | TA287(28HP) | 耕耘軸小 | Rotary Small | AQ2407E | 40*65*11/18 |
| ISEKI | TA287(28HP),TL4500 | 傳動 PTO 合體 | Transmission PTO | | 45*60*9 |
| ISEKI | TA287(28HP),TL4500 | 傳動 PTO 合體 | Transmission PTO | | 35*45*17 |
| ISEKI | TA417 | 耕耘軸小 | Rotary Small | AQ2688E | 45*72*13/20 |
| ISEKI | TA417/41 HP | 耕耘軸大 | Rotary Big | AQ3067E | 55*82*10.5/17 |
| ISEKI | TL2800 | | | AE3527E | 70*95*13 |
| ISEKI | TL4100 | 後輪 | Rear Wheel | | 75*90*21 |
| ISEKI | TL4500 | 耕耘軸大 | Rotary Big | AE1723F | 60*90*10 |
| ISEKI | TL4500(45HP) | 耕耘軸大 | Rotary Big | AQ7242E | 60*90*12/18 |
| ISEKI | TS3110F(4WD) | 前輪站軸 | Front Wheel Vertical Shaft | | 55*72*9 |
| ISEKI | TS3110F(4WD) | 前輪橫軸 | Front Wheel Horizontal Shaft | | 55*78*10 |
| ISEKI | TS3110F(4WD) | 後輪(牛腳) | Rear Wheel | | 60*100*14/26 |
| ISEKI | TS3110F(4WD) | 耕耘軸大 | Rotary Big | AQ3074E | 55*85*13/19 |
| ISEKI | TS3110F(4WD) | 耕耘軸小 | Rotary Small | AQ2407E | 40*65*11/18 |
| ISEKI | TS3110F(4WD) | 傳動 PTO 合體 | Transmission PTO | | 45*60*9 |
| ISEKI | TS3110F(4WD) | 傳動 PTO 合體 | Transmission PTO | | 35*45*17 |
| ISEKI | TS3510(35HP) | 前輪 | Front Wheel | | 48*65*9 |
| ISEKI | TS3510(35HP) | 前輪(2WD) | Front Wheel (2WD) | | 35*40*17 |
| ISEKI | TS3510(35HP) | 後輪 牛腳 | Rear Wheel | | 60*100*14/26 |
| ISEKI | TS3510(35HP) | 耕耘軸大 | Rotary Big | AQ3074E | 55*85*13/19 |
| ISEKI | TS3510(35HP) | 耕耘軸小 | Rotary Small | | 35*60*12/18 |

WLK Agriculture Machine Used Products.

DATE : 2014/01/03

| BRAND | MODEL | 用處 | APPLICATION | Part No. | Oil Seals Size |
|------------|----------------------|--------------------------|---|-------------|-----------------|
| ISEKI | TS3510(35HP) | 傳動 PTO 合體 | Transmission PTO | | 40*60*10 |
| ISEKI | TS3510(35HP) | 傳動 PTO 合體 | Transmission PTO | | 45*60*9 |
| ISEKI | TS3510(35HP) | 傳動 PTO 合體 | Transmission PTO | | 35*40*17 |
| ISEKI | 太郎 | | | | 15*35*7 |
| ISEKI | 太郎 | | | | 15*35*8 |
| ISEKI | 太郎 | | | | 30*43*9 |
| ISEKI | 太郎 | | | | 20*47*12 |
| ISEKI | 太郎 | | | | 20*47*9 |
| ISEKI | 太郎 | | | | 32*48*8 |
| ISEKI | 太郎 | | | | 40*62*12 |
| JOHN DEERE | | 前輪 | Front Wheel | | 165*190*15/21 |
| JOHN DEERE | 1750 | 前驅入力軸 | Front Transmission Intake Shaft | | 45*68*12 |
| JOHN DEERE | 1750 " | 前輪 | Front Wheel | | 125*150*14 |
| JOHN DEERE | 1750 " | 前輪傳動軸 | Front Wheel Transmission Shaft | | 36*52*15 |
| JOHN DEERE | 2140 | 後輪 | Rear Wheel | | 76*118*17/20 |
| JOHN DEERE | 2140/3350 | 傳動PTO(1000轉) | Transmission PTO (1000rpm) | | 35*52*11 |
| JOHN DEERE | 3140 | 方向油壓 | Steering Hydraulic | | AS251 |
| JOHN DEERE | 3140 | 前輪 | Front Wheel | | 165*190*15/21 |
| JOHN DEERE | 3140 | 後輪 | Rear Wheel | | 90*140*17/20 |
| JOHN DEERE | 3350 | 傳動PTO | TransmissionPTO | AQ2671E | 45*68*11/17 |
| JOHN DEERE | 3640/3140 | 前輪(4WD) | Front Wheel (4WD) | | 145*170*17/21.5 |
| JOHN DEERE | 6400/8400PTO | 所有前輪 | Front Wheel | AQ8275P | 70*95*12/18 |
| JOHN DEERE | 6800/7800 Series | 傳動PTO(改裝) | TransmissionPTO(Alternated) | | 65*95*11/18 |
| KOBASHI 小橋 | | KS/ KT/KA/KSD輕型耕軸小.三(曳)4 | KS/ KT/KA/KSD Light Type Rotary Small | AQ7242E | 60*90*12/18 |
| KOBASHI 小橋 | | KT/KA 輕型 耕軸大,野馬5000耕 | KT/KA Light Type Rotary Big | AQ3563E | 72*100*13/17 |
| KOBASHI 小橋 | 1.5米 | 耕軸大 | Rotary Big | AQ2881P | 50*78*10/17 |
| KOBASHI 小橋 | 1.7米 | 耕軸大 | Rotary Big | AQ8177P | 60*90*10/17 |
| KOBASHI 小橋 | 1.7米 | 耕軸小 | Rotary Small | | 50*80*10/17 |
| KOBASHI 小橋 | 1.7米 | 橫軸 | Horizontal Shaft | | 55*72*9 |
| KOBASHI 小橋 | 1.9米 | 耕軸大 | Rotary Big | AQ3563E | 72*100*13/17 |
| KOBASHI 小橋 | 1.9米 | 耕軸小 | Rotary Small | AQ7242E | 60*90*12/18 |
| KOBASHI 小橋 | 260 /280 | 橫向傳動軸 | Horizontal Transmission Shaft | 93546809012 | 68*90*12 |
| KOBASHI 小橋 | KS 200 / 240 | 入力軸 PTO | Intake Shaft PTO | 92504006212 | 40*62*12 |
| KOBASHI 小橋 | 280/240/260 | 耕軸大 | Rotary Big | 93597511020 | 75*110*12/20 |
| KOBASHI 小橋 | KSD 241TA | 代用 | Replacement | | 40*62*12 |
| KOBASHI 小橋 | KSD 241TA | 入力軸 PTO | Intake Shaft PTO | 93504006212 | 40*62*12 |
| KOBASHI 小橋 | KSD 241TA | 耕軸大 | Rotary Big | 93597511020 | 75*110*12/20 |
| KOBASHI 小橋 | KSD 241TA | 耕軸小 | Rotary Small | 93596009018 | 60*90*12/18 |
| KOBASHI 小橋 | KSD 241TA | 橫向傳動軸 | Horizontal Transmission Shaft | 93546809012 | 68*90*12 |
| KOBASHI 小橋 | KSD240/260/280 | 耕軸小 | Rotary Small | 93596009018 | 60*90*12/18 |
| KOBASHI 小橋 | KT 180KT 200KT/KA | (AQ3563E) | Big(AQ3563E) | 93597210017 | 72*100*13/17 |
| KOBASHI 小橋 | KT 180KT 200KT/KA | 耕軸小 | Rotary Small | 93596009018 | 60*90*12/18 |
| KOBASHI 小橋 | KT 180KT 200KT/KA | 橫向傳動軸 | Horizontal Transmission Shaft | 93529012013 | 90*120*13 |
| KOBASHI 小橋 | KT 180KT 200KT/KA | 橫向傳動軸(舊型) | Horizontal Transmission Shaft(Old Type) | | 60*82*12 |
| KOBASHI 小橋 | KT 180KT 200KT/KA 通用 | 入力軸 PTO | Intake Shaft PTO | 93504006212 | 40*62*12 |
| KOBASHI 小橋 | KT200 | 耕軸大,小 | Rotary Big, Small | | 60*90*12/18 |

WLK Agriculture Machine Used Products.

DATE : 2014/01/03

| BRAND | MODEL | 用處 | APPLICATION | Part No. | Oil Seals Size |
|------------|--------------------------|--------------|-------------------------------------|-------------|----------------|
| KOBASHI 小橋 | M141ST , M151ST , M161ST | 入力軸 PTO | Intake Shaft PTO | 93564006212 | 40*62*12 |
| KOBASHI 小橋 | M141ST , M151ST , M161ST | 耕耘軸大,小 | Rotary Big, Small | 93585007816 | 50*78*10/17 |
| KOBASHI 小橋 | M141ST , M151ST , M161ST | 輪軸 | Wheel Shaft | 93543505008 | 35*50*8 |
| KOBASHI 小橋 | M171ST | 入力軸 PTO | Intake Shaft PTO | 93544006214 | 40*62*12 |
| KOBASHI 小橋 | M171ST | 耕耘軸大,小 | Rotary Big, Small | 93586009018 | 60*90*12/18 |
| KOBASHI 小橋 | M171ST | 輪軸 | Wheel Shaft | 93543505008 | 35*50*8 |
| KUBOTA | | | | AE0683E | 16*28*5.5/6.5 |
| KUBOTA | | | | AE0742I | 17*30*7 |
| KUBOTA | | | | AE1314R | 25*40*7 |
| KUBOTA | | | | | 5尺6加油線 Cable |
| KUBOTA | | 分解HST泵(油泵) | HST(Oil Pump) | 04811-00110 | P11 |
| KUBOTA | | 分解HST泵(油泵) | HST(Oil Pump) | 04810-00140 | P14 |
| KUBOTA | | 分解HST泵(油泵) | HST(Oil Pump) | 04810-00180 | P18 |
| KUBOTA | | 分解HST泵(馬達) | HST(Motor) | 04810-00110 | P11 |
| KUBOTA | | 分解HST泵(馬達) | HST(Motor) | 04810-00120 | P12 |
| KUBOTA | | 分解油壓泵 | HST(Oil Pump) | 04810-50500 | G50 |
| KUBOTA | | 扶起變速箱 | Speed Changing Case | 04811-00120 | P12 |
| KUBOTA | | 油箱 | Oil Tank | 04811-50300 | G30 |
| KUBOTA | | 油箱 | Oil Tank | 04811-00160 | P16 |
| KUBOTA | | 油壓 幫浦 | Hydraulic Pump | 04810-00220 | P20 |
| KUBOTA | | 油壓 幫浦 | Hydraulic Pump | 04810-00050 | P5 |
| KUBOTA | | 油壓 幫浦 | Hydraulic Pump | 04811-10500 | S50 |
| KUBOTA | | 油壓油冷卻器 | cooler | 04811-00380 | P38 |
| KUBOTA | | 油壓管 | Hydraulic Pipe | 04811-06170 | P18 |
| KUBOTA | | 油壓管 | Hydraulic Pipe | 04811-00180 | P18 |
| KUBOTA | | 油壓管 | Hydraulic Pipe | 04811-10850 | S85 |
| KUBOTA | | 活塞 曲軸 | Valve Crank Shaft | 04811-10300 | S30 |
| KUBOTA | | 傳動外部 | Transmission | 04815-50650 | G65 |
| KUBOTA | | 裝配HST泵 | HST Pump | 04811-10700 | S70 |
| KUBOTA | | 閥整件 | Valve Kit | 04811-00140 | P14 |
| KUBOTA | | 閥整件 | Valve Kit | 04810-00080 | P8 |
| KUBOTA | | 閥整件 | Valve Kit | 04811-00080 | P8 |
| KUBOTA | | 閥整件 | Valve Kit | 04811-00090 | P9 |
| KUBOTA | | 齒輪箱 | Gear Box | 04811-00200 | P20 |
| KUBOTA | | 燃油箱 | Fuel Tank | 04811-00710 | P71 |
| KUBOTA | 17HP | 軸心油封 | Crank Shaft | | 50*70*8 |
| KUBOTA | 17HP | 軸心油封 | Crank Shaft | | 45*55*27 |
| KUBOTA | 2000 | 後輪 | Idler | | 35*62*10 |
| KUBOTA | 2000 | 滾輪 | Track Roller | | 30*52*11 |
| KUBOTA | 2000 | 滾輪 | Track Roller | | 25*30*14 |
| KUBOTA | 2000 2200 | 碗輪蓋 | Track Roller | | 47/54*9.5 |
| KUBOTA | 2000 2200 | 碗輪蓋 | Track Roller | | 52/60*8.5 |
| KUBOTA | 22/26/42/45H | 耕耘軸小 | Rotary Small | AQ7963P | 38*65*14/17 |
| KUBOTA | 25HP鐵牛用 | | | | 尺 |
| KUBOTA | 2750 | 車軸 | Axle | BQ2999E | 40*80*12 |
| KUBOTA | 2750/3550 | 滾輪 | Track Roller | AQ1749E | 30*62*11 |
| KUBOTA | 2800/3000/3500 | 滾輪 尾輪通用 | Track Roller & Idler used | | 25*62*10.5/17 |
| KUBOTA | 4500/5500(4WD) | 大王消(兩片式, 2-1 | Front Wheel Bearing (2pcs type, 2-1 | BW2436E | 55*85*10 |
| KUBOTA | 4500/5500(4WD) | 前輪 | Front Wheel | AE3513F | 70*90*12 |
| KUBOTA | 4550 | 前輪帶動下面 | Front Wheel Transmission Lower | | 45*75*13/19 |
| KUBOTA | 4550 | 後輪 | Rear Wheel | 36200-48251 | 70*95*12/18 |
| KUBOTA | 4550 | 耕耘軸大 | Rotary Big | 32218-55352 | 45*75*14/17 |

WLK Agriculture Machine Used Products.

DATE : 2014/01/03

| BRAND | MODEL | 用處 | APPLICATION | Part No. | Oil Seals Size |
|--------|-----------------|--------------------------|---|---------------|-----------------|
| KUBOTA | 4550 | 傳動 PTO 合體 | Transmission PTO | | 38*56*11 |
| KUBOTA | 4550 | | | | 32*38*14 |
| KUBOTA | 5500 | 前輪橫軸 | Front Wheel Horizontal Shaft | AQ3408E | 65*90*12/18 |
| KUBOTA | 5500 7500 | 前輪(舊型) | Front Wheel (Old Type) | AQ3408E | 65*90*12/18 |
| KUBOTA | 5500/7500 | 久保(曳)5500/7500 變速箱內 | Speed Changing Case Inner | AE2250E | 38*62*11 |
| KUBOTA | 5500/7500 | 後輪 | Rear Wheel | AQ8124P | 85*110*12 |
| KUBOTA | 5500/7500 (4WD) | 前輪舊型(6030/80) | Front Wheel Old Type (6030/80) | AQ3408E | 65*90*12 |
| KUBOTA | 5500/7500/8900 | 後輪 | Rear Wheel | AQ8142P | 85*110*12 |
| KUBOTA | 6030/8030共用 | 前輪 | Front Wheel | | 70*90*12 |
| KUBOTA | 725 | 曲軸後油封 | Crank Shaft | AH3734E | 80*100*13 |
| KUBOTA | 7500 | 前輪新型 | Front Wheel New Type | AQ8275P | 70*95*12/18 |
| KUBOTA | 7500 | 傳動 PTO | Transmission PTO | AQ7745E | 35*58*11.4/17 |
| KUBOTA | 7500 | 傳動 PTO/L2202前輪/L2202~L1- | Transmission PTO/L2202Front Wheel /L2202~L1- | AQ7745E | 35*58*11.4/17 |
| KUBOTA | 7500 5500 | 前輪(舊型) | Front Wheel (Old Type) | AQ3408E | 65*90*12/18 |
| KUBOTA | 7500 5500 | 後輪 | Rear Wheel | AQ8124P | 85*110*12/18 |
| KUBOTA | 7500 5500 | 耕耘軸大 | Rotary Big | AQ7242E | 60*90*12/18 |
| KUBOTA | 7500 5500 | 耕耘軸小 | Rotary Small | 32218-55352 | 45*75*14/17 |
| KUBOTA | 7500 5500 | 傳動 PTO | Transmission PTO | | 38*58*11 |
| KUBOTA | 7500,M1 Series | 前輪 | Front Wheel | BQ3916E | 70*95*12/18 |
| KUBOTA | 7500/8900 | 時規油封 | Timing Oil Seals | AH2507P | 42*65*12 |
| KUBOTA | 7500/8900 (4WD) | 大王消.立腿油封 (2WD) | Front Wheel Bearing. Vertical Shaft Oil Seals (2WD) | AW3232E | 60*85*10 |
| KUBOTA | 8 HP | 眼頭 | Planting Arm Cam Shaft | | 15*35*9 |
| KUBOTA | 8500 | 前輪橫軸 | Front Wheel Horizontal Shaft | BQ3519E | 70*95*12/18 |
| KUBOTA | 8950(2WD) | 前輪 | Front Wheel | AQ2890E | 50*80*10/17 |
| KUBOTA | 8950(2WD) | 前輪(新型) | Front Wheel (New Type) | AQ3020P | 54*80*13.5/15.8 |
| KUBOTA | 8950(2WD) | 前輪下面 (有擔) | Front Wheel Lower (有擔) | | 70*95*12/18 |
| KUBOTA | 8950(2WD) | 耕耘軸大 | Rotary Big | | 50*80*10 |
| KUBOTA | 8950(4WD) | 前輪橫軸 | Front Wheel Horizontal Shaft | BQ3519E | 70*95*12/18 |
| KUBOTA | ER1 LC-14 | 曲軸 | Crank Shaft | 09035-07010 | 50*70*10 |
| KUBOTA | ER17(KMS) | | | AQ8305P | 45*70*12/17 |
| KUBOTA | ER17(KMS) | | | 09505-07210 | 50*72*10 |
| KUBOTA | ER17(KMS) | 主齒輪箱 | Main Gear Case | | 45*70*8.5 |
| KUBOTA | ER17(KMS) | 主齒輪箱, 車軸 | Main Gear Case , Axle | 09230-45705 | 45*70*5 |
| KUBOTA | ER17(KMS) | 主齒輪箱, 車軸 | Main Gear Case , Axle | 09504-57012 | 45*70*12 |
| KUBOTA | ER17(KMS) | 耕耘軸大 | Rotary Big | 09505-372102B | 53*72*10 |
| KUBOTA | ER17(KMS) | 耕耘軸大 | Rotary Big | | 45*53*30.5 |
| KUBOTA | ER17(KMS),20 HP | 耕耘軸 | Rotary | 09500-35529 | 35*52*9 |
| KUBOTA | ER17(KMS),20 HP | 副齒輪箱部 | Auxiliary Gear Case System | 09230-30525 | 30*52*5 |
| KUBOTA | ER17,20 HP | 曲軸 | Crank Shaft | 09560-54768 | 54*76*8 |
| KUBOTA | ER17HP | | | | 邊皮 |

WLK Agriculture Machine Used Products.

DATE : 2014/01/03

| BRAND | MODEL | 用處 | APPLICATION | Part No. | Oil Seals Size |
|--------|--------------|---------------|-----------------------------------|-------------|----------------|
| KUBOTA | ER17HP,ER20 | 橫向傳動軸 | Horizontal Transmission Shaft | 09230-35616 | 35*61*6 |
| KUBOTA | ER20HP | | | | 20*35*7 |
| KUBOTA | ER20HP | | | | 10*18.5*2 |
| KUBOTA | ER20HP | | | | 12*22*2 |
| KUBOTA | ER20HP | | | | 邊皮 |
| KUBOTA | ER20HP | 主離合器 | Main Clutch | 09230-13264 | 13*26*4 |
| KUBOTA | ER20HP | 主離合器 | Main Clutch | 64135-11311 | 6*13.5*2 |
| KUBOTA | ER20HP | 主煞車 | Main Brake | 09400-20306 | 20*30*6 |
| KUBOTA | ER20HP | 主齒輪箱部 車軸 | Main Gear Case System Axle | 09230-50725 | 50*72*5 |
| KUBOTA | ER20HP | 主齒輪箱部 車軸 | Main Gear Case System Axle | 09505-07212 | 50*72*12 |
| KUBOTA | ER20HP | 主齒輪箱部 輪軸 | Main Gear Case System Wheel Shaft | | 45*72*5 |
| KUBOTA | ER20HP | 主齒輪箱部 輪軸 | Main Gear Case System Wheel Shaft | | 45*72*12 |
| KUBOTA | ER20HP | 主離合器 | Main Clutch | 09400-22357 | 22*35*7 |
| KUBOTA | ER20HP | 曲軸 | Crank Shaft | | 50*70*12 |
| KUBOTA | ER20HP | 曲軸 (引擎用) | Crank Shaft (Engine Used) | 14941-23551 | 48*70*12 |
| KUBOTA | ER20HP | 尾輪 | Idler | | 20*47*12 |
| KUBOTA | ER20HP | 尾輪 | Idler | | 20*47*10 |
| KUBOTA | ER20HP | 尾輪 | Idler | | 20*52*10 |
| KUBOTA | ER20HP | 油杯 P 38.1X3.2 | Oil Cup P 38.1X3.2 | | P 39*3.3 |
| KUBOTA | ER20HP | 耕耘軸大 | Rotary Big | | 53*72*10 |
| KUBOTA | ER20HP | 耕耘軸大 | Rotary Big | | 45*53*30.5 |
| KUBOTA | ER20HP | 耕耘軸小 | Rotary Small | 09500-38529 | 38*52*9 |
| KUBOTA | ER20HP | 耕耘軸小 | Rotary Small | 64135-92791 | 30*38*28.5 |
| KUBOTA | ER20HP | 起動 | Starting | 09550-27407 | 27*40*7 |
| KUBOTA | ER20HP | 起動 | Starting | 14311-62451 | 22*27*12 |
| KUBOTA | ER20HP | 傳動(後) | Transmission (Rear) | 64135-32231 | 8*18.2*2 |
| KUBOTA | ER20HP | 輪軸 | Wheel Shaft | AQ2869E | 50*72*12 |
| KUBOTA | ER40 , ER50 | 曲軸主軸部 | Crank Shaft Main Shaft System | | 35*48*8 |
| KUBOTA | ER40HP | 曲軸 | Crank Shaft | | 33*48*8 |
| KUBOTA | ER5HP | 油杯 P 38.1X3.2 | Oil Cup P 38.1X3.2 | | P 39*3.3 |
| KUBOTA | ER8HP(KR850) | | | | 操向鋼索(新型) |
| KUBOTA | ER8HP(KR850) | 曲軸主軸箱 | Crank Shaft Main Shaft Case | | 40*62*8 |
| KUBOTA | ER8HP(KR850) | 油杯 P 38.1X3.2 | Oil Cup P 38.1X3.2 | | P 39*3.3 |
| KUBOTA | ER8HP(KR850) | 後傳動部 耕耘軸 | Rear Transmission System Rotary | | 32*40*20 |
| KUBOTA | ER8HP(KR850) | 耕耘軸 | Rotary | | 40*55*8 |
| KUBOTA | ER8HP(KR850) | 耕耘軸(2齒) | Rotary (2T) | | 30*40*23/25 |
| KUBOTA | ER8HP(KR850) | 起動 | Starting | | 25*32*6.5 |
| KUBOTA | ER8HP(KR850) | 輪軸(新型) | Wheel Shaft (New Type) | | 35*72/80*13 |
| KUBOTA | ER8HP(KR850) | 輪軸(新型) | Wheel Shaft (New Type) | | 40*80/88*12.5 |
| KUBOTA | ER8HP(KR850) | 輪軸(舊型) | Wheel Shaft (Old Type) | | 40*62/72*13.5 |
| KUBOTA | GA70 | Collar | Collar | 1430162452 | 22*27*12 |
| KUBOTA | GA70 | 曲軸 CRANK | Crank Shaft | 0956035488 | 35*48*8 |
| KUBOTA | GA70 | 起動 STARTING | Starting | 09550-27407 | 27*40*7 |
| KUBOTA | GL | ROTARY | ROTARY | 63313-32540 | 浮動油封 |

WLK Agriculture Machine Used Products.

DATE : 2014/01/03

| BRAND | MODEL | 用處 | APPLICATION | Part No. | Oil Seals Size |
|--------|----------------------------|---------------------------|---|--------------|--------------------|
| KUBOTA | GL33/GL53 | 前傳動軸(由變速箱傳出的) | Front Transmission Shaft(From Speed Changing Case Output) | AE1307E | 25*38*8 |
| KUBOTA | GL33/GL53/L1-45 | 前曲軸 | Front Crank Shaft | AH2483E | 40*55*9 |
| KUBOTA | GL53 | 倍速軸 | Speed Shaft | AE0997E | 20*32*8 |
| KUBOTA | HA 900 | 後輪 | Idler | | 30*45*8 |
| KUBOTA | HXD 7 | 曲軸 | Crank Shaft | | 63*80*9 |
| KUBOTA | HXD 7 | 傳動 | Transmission | | 35*55*11 |
| KUBOTA | HXD 7 | 傳動 | Transmission | | 40*62*12 |
| KUBOTA | HXD 7 | 傳動軸 合體 | Transmission Shaft | | 40*62/72*13.5 |
| KUBOTA | HXD 7 | 傳動軸 合體 | Transmission Shaft | | 30*40*23/25 |
| KUBOTA | HXD 7 | 滾輪 | Track Roller | | 25*47*10 |
| KUBOTA | K120 | 耕耘軸 | Rotary | 63633-3134-1 | 30*62/72*21 |
| KUBOTA | K120,KO232, | 輪軸(Angle) | Wheel Shaft (Angle) | 63681-17170 | 50*68*12.5 |
| KUBOTA | K120,KO290 | 耕耘軸 | Rotary | 63633-3134-1 | 30*62/72*21 |
| KUBOTA | K75(GA70 引擎) | 曲軸 | Crank Shaft | 09560-35488 | 35*48*8 |
| KUBOTA | K75(GA70 引擎) | 起動 | Starting | | 15*30*7 |
| KUBOTA | K75(GA70 引擎) | 起動 | Starting | 09550-27407 | 27*40*7 |
| KUBOTA | K75(GA70 引擎) | 起動 | Starting | 14311-6245-1 | 22*27*12 |
| KUBOTA | K75(GA70) | | | | 22*35*8 |
| KUBOTA | K75(GA70) | | | 09400-24408 | 24*40*8 |
| KUBOTA | K75(GA70) | | | 09400-25457 | 25*45*7 |
| KUBOTA | K75(GA70) | | | | 20*45*8 |
| KUBOTA | K75(GA70),KO232, | 輪軸(Angle) | Wheel Shaft (Angle) | 63681-17170 | 50*68*12.5 |
| KUBOTA | K75(GA70),KO290 | 耕耘軸 ROTARY | Rotary ROTARY | 63633-3134-1 | 30*62/72*21 |
| KUBOTA | L1-455 | 引擎 | Engine | | 20*30*8 |
| KUBOTA | L1-455 | 引擎 | Engine | | 32*46*8 |
| KUBOTA | L1-455 | 油壓幫浦 | Hydraulic Pump | AP0598A | 15*30*7 |
| KUBOTA | L1-455 | 前輪橫軸 | Front Wheel Horizontal Shaft | 31393-43530 | 45*75*14/17 |
| KUBOTA | L1-455 | 耕耘軸大 | Rotary Big | | 45*75*14/17 |
| KUBOTA | L1500 | ROTARY | ROTARY | AZ7449E | 50*90*12/21 |
| KUBOTA | L1500DT | BRAKE | BRAKE | AE1748I | 30*62*10 |
| KUBOTA | L1500DT/L1501 | CTR.DRIVE ROT. | CTR.DRIVE ROT. | AZ7449E | 50*90/98*12.7/14.5 |
| KUBOTA | L1501 | ROTARY | ROTARY | AZ7913E | 65*100*12/19 |
| KUBOTA | L2202 | 前輪下面 | Front Wheel Lower | 37650-43530 | 35*58*11.4/17 |
| KUBOTA | L2202 | 耕耘軸小 | Rotary Small | | 38*65*14/17 |
| KUBOTA | L2202、L2200 | 耕耘軸大 | Rotary Big | AQ2693E | 45*75*14/17 |
| KUBOTA | L2202、L2000,L1501 | 後輪 | Rear Wheel | AQ7747E | 52*85*16/19 |
| KUBOTA | L2202/(4202舊車)/L1-45 | 耕耘軸大,久 | Rotary Big | AQ2693E | 45*75*14/17 |
| KUBOTA | L2202/3001/4202/26HP/L1-45 | 耕耘軸 | Rotary | AQ7963P | 38*65*14/17 |
| KUBOTA | L2602 | FRT.WHEEL SPINDLE UPR LWR | FRT.WHEEL SPINDLE UPR LWR | AG1524P | 28*34*5 |
| KUBOTA | L3001DT | 曲軸 | Crank Shaft | 15221-04461 | 80*100*13 |
| KUBOTA | L3001DT | 前輪 | Front Wheel | AQ8136P | 45*75*13/19 |
| KUBOTA | L3001DT | 前輪下面 | Front Wheel Lower | 37300-11431 | 35*62*13/15.5 |
| KUBOTA | L3001DT | 前輪上面 | Front Wheel Upper | 37300-11161 | 42*55/63*12 |
| KUBOTA | L3001DT | 後輪 | Rear Wheel | 37300-27561 | 65*100*17/19 |
| KUBOTA | L3001DT | 後輪 | Rear Wheel | AQ7984P | 65*100*12/19 |
| KUBOTA | L3001DT | 耕耘軸大 | Rotary Big | 705365-5131 | 55*82*10.5/17 |
| KUBOTA | L3001DT | 耕耘軸小 | Rotary Small | 705365-5231 | 38*65*14/17 |
| KUBOTA | L3001DT | 傳動 PTO | Transmission PTO | | 35*55*11 |
| KUBOTA | L3001DT | | | | 30*35*15 |
| KUBOTA | L4202DT | 前輪下 | Front Wheel 下 | AQ2422E | 40*72*13/16 |
| KUBOTA | L4202DT | 前輪下面 | Front Wheel Lower | 36200-48250 | 40*72*15/16 |

WLK Agriculture Machine Used Products.

DATE : 2014/01/03

| BRAND | MODEL | 用處 | APPLICATION | Part No. | Oil Seals Size |
|--------|-------------------------|------------------|------------------------------------|--------------|------------------|
| KUBOTA | L4202DT | 前輪下面 | Front Wheel Lower | AQ8699P | 40*72*13/16 |
| KUBOTA | L4202DT | 前輪帶動下面 | Front Wheel Transmission Lower | AQ8136P | 45*75*13/19 |
| KUBOTA | L4202DT | 後傳動 | Rear Transmission | | 35*55*8 |
| KUBOTA | L4202DT | 後輪 | Rear Wheel | 36200-48251 | 70*95*12/18 |
| KUBOTA | L4202DT | 耕耘軸大 | Rotary Big | 32218-55352 | 45*75*14/17 |
| KUBOTA | L4202DT | 耕耘軸大 | Rotary Big | | 72*100*13/17 |
| KUBOTA | L4202DT | 耕耘軸小 | Rotary Small | 70536-55230 | 38*65*14/17 |
| KUBOTA | L4202DT | 耕耘軸小 | Rotary Small | | 55*82*10.5/17 |
| KUBOTA | L4202DT | 耕軸大 | Rotary Big | AQ8177P | 60*90*10 |
| KUBOTA | L4202DT | 傳動 PTO 合體 | Transmission PTO | | 38*56*11 |
| KUBOTA | L4202DT | | | | 32*38*14 |
| KUBOTA | L4202DT(4WD)/L1-45/GL53 | 前輪軸 | Front Wheel Shaft | AQ8136P | 45*75*13/19 |
| KUBOTA | L4202DT/4500/L45/GL53 | 後輪 //5500/75 | Rear Wheel //5500/75 | BQ3519E | 70*95*12/18 |
| KUBOTA | M1 Series | 前輪通用 | Front Wheel Used | BQ3916E | 70*95*12/18 |
| KUBOTA | M4000DT | | | AQ7021E | 65*100*11/18 |
| KUBOTA | PRO481 | 水平活動座 | Horizontal Equalizer | | 35*45*7 |
| KUBOTA | PRO481 | 導輪座 | Conduct Wheel Base | | 16*25*7 |
| KUBOTA | PRO481M | | | | 30*42*8 |
| KUBOTA | PRO481M | (佩輪)炮管 | Carry Roller | 51601-1595-0 | 20*47*12/14 |
| KUBOTA | PRO481M | V2203DIC1引擎汽門 | V2203DIC1Engine Valve | 15221-1315-0 | 8*13/15.3*7.5/10 |
| KUBOTA | PRO481M | 補助輪上面 | Carry Roller Upper | 52200-23330 | 20*42*9/12 |
| KUBOTA | PRO481M | 導輪 | Carry Roller | | 28*42*8 |
| KUBOTA | PRO481M | 導輪 | Carry Roller | | 20*30*12.6 |
| KUBOTA | PRO601 | | | | 60*68*5/6.5 |
| KUBOTA | PRO601 | 2 號軸鏈條 | No. 2 Shaft Chain | 09500-30478 | 30*47*8 |
| KUBOTA | PRO601 | 2 號驅動箱 | No. 2 Transmission Case | 09230-25405 | 25*40*5 |
| KUBOTA | PRO601 | F2803DIC引擎曲軸 | F2803DICEngineCrank Shaft | | 42*55*9 |
| KUBOTA | PRO601 | HST幫浦(高壓力) | HST Hydraulic Pump (High Pressure) | 58700-1129-0 | 25*40*7 |
| KUBOTA | PRO601 | No. 1 輸送軸 | No. 1 Transit Shaft | 09500-30528 | 30*52*8 |
| KUBOTA | PRO601 | No. 1 輸送軸,2 號軸鏈條 | No. 1Transit Shaft,No. 2 Chain | 09500-25477 | 25*47*7 |
| KUBOTA | PRO601 | 可動輪軸(佩輪) | Carry Roller | 51601-1595-0 | 20*47*12/14 |
| KUBOTA | PRO601 | 尾輪 | Idler | 55611-24220 | 25*62*10.5/17 |
| KUBOTA | PRO601 | 尾輪 改裝 | Idler Alternated | | 25*62*11/16 |
| KUBOTA | PRO601 | 尾輪 改裝 | Idler Alternated | | 40*62/72*13.5 |
| KUBOTA | PRO601 | 汽門 | Valve | 15221-1315-0 | 8*13/15.3*7.5/10 |
| KUBOTA | PRO601 | 炮管螺旋軸 | Transit Scroll Shaft | 09500-25478 | 25*47*8 |
| KUBOTA | PRO601 | 割刀曲柄 | Reaping Shaft | 59700-5836-0 | 47/56*5/18 |
| KUBOTA | PRO601 | 割刀曲軸 | Reaping Shaft | 52500-2195-0 | 25*35*7 |
| KUBOTA | PRO601 | 割刀曲軸 | Harvesting Blade Shaft | 67121-5674-0 | 35*52*8 |
| KUBOTA | PRO601 | 滾輪(改裝) | Track Roller (Alternated) | | 25*52*16 |
| KUBOTA | PRO601 | 滾輪(改裝) | Track Roller (Alternated) | | 30*62*11/17 |
| KUBOTA | PRO601 | 滾輪(改裝) | Track Roller (Alternative) | | 62/72*10 |
| KUBOTA | PRO601 | 導輪(補助輪) | Carry Roller | 52200-2333-0 | 20*42*9/12 |
| KUBOTA | PRO601 | 機油箱內部 | Oil Case Inner | 52200-1275-0 | 35*72*10 |
| KUBOTA | PRO601 | 機油箱內部 | Oil Tank Inner | 54617-2283-0 | 30*35*15 |
| KUBOTA | PRO601(R9101G) | 螺旋軸(2番) | Scroll Shaft(NO 2) | 09500-20358 | 20*35*8 |

WLK Agriculture Machine Used Products.

DATE : 2014/01/03

| BRAND | MODEL | 用處 | APPLICATION | Part No. | Oil Seals Size |
|--------|------------------------|--------------|-------------------------------------|--------------|------------------|
| KUBOTA | PRO601(R9101G) | 變速箱 | Speed Changing Case | 52200-1642-0 | 25*40*8 |
| KUBOTA | PRO601(R9101G) | 變速箱 | Speed Changing Case | 52200-1542-0 | 28*47*8 |
| KUBOTA | PRO601(R9101G)/PRO481M | 螺旋軸(2重) | Scroll Shaft (2nd Step) | 09500-22358 | 22*35*8 |
| KUBOTA | PRO601(R9101G)/SR75 | HST幫浦(高壓力) | HST Hydraulic Pump (High Pressure) | 58700-1133-0 | 25*35*7 |
| KUBOTA | PRO601/PRO481M | | | | 30*35*15 |
| KUBOTA | PRO601/PRO481M | 2號驅動箱 | No. 2 Transmission Case | 09230-25405 | 25*40*5 |
| KUBOTA | PRO601/PRO481M | 水平座 | Horizontal Base | | 40*55*8 |
| KUBOTA | PRO601/PRO481M | 仰穀軸箱2號驅鏈條 | Lifting Device, No. 2 Transit Chain | 09500-30478 | 30*47*8 |
| KUBOTA | PRO601/PRO481M | 仰穀軸箱2號驅鏈條 | Lifting Device, No. 2 Transit Chain | 09500-25477 | 25*47*7 |
| KUBOTA | PRO601/PRO481M | 尾輪(改裝) | Idler (Alternated) | | 30*62*11 |
| KUBOTA | PRO601/PRO481M | 尾輪(改裝) | IDLER (Alternated) | | 62*72*10 |
| KUBOTA | PRO601/PRO481M | 尾輪(新型) | Idler (New Type) | | 30*72*14/16.3 |
| KUBOTA | PRO601/PRO481M | 尾輪(舊型改裝) | Idler (Old Type Alternated) | 55611-24220 | 25*62*10.5/17 |
| KUBOTA | PRO601/PRO481M | 車心(七齒) | Transmission Shaft 7T | 55611-1715-0 | 40*80*18.5/20.5 |
| KUBOTA | PRO601/PRO481M | 活動輪(佩輪)副輪 | Carry Roller | 23-20-130 | 20*47*12 |
| KUBOTA | PRO601/PRO481M | 補助輪 | Carry Roller | 52200-23330 | 20*42*9/12 |
| KUBOTA | PRO601/PRO481M | 滾輪 | Track Roller | 68741-2135-0 | 浮動式油封 |
| KUBOTA | PRO601/PRO481M | 滾輪(改裝型) | Track Roller (Alternated Type) | | 30*62*11/17 |
| KUBOTA | PRO601/PRO481M | 機油箱內部 | Oil Case Inner | 52200-1275-0 | 35*62*10 |
| KUBOTA | PRO601/PRO481M | 機油箱內部 | Oil Case Inner | 09503-06210 | 30*62*10 |
| KUBOTA | PRO601/PRO481M | 機油箱內部 | Oil Tank Inner | 54617-2283-0 | 30*35*15 |
| KUBOTA | PRO601/PRO481M | 螺旋軸(2重) | Step) | 09500-20358 | 20*35*8 |
| KUBOTA | R1-43 | | | | 17*35*7 |
| KUBOTA | R1-43 | | | | 17*40*7 |
| KUBOTA | R1-43 | | | | 20*42*8 |
| KUBOTA | R1-43 | | | | 35*62*10 |
| KUBOTA | R1-43 | | | | 30*62*8 |
| KUBOTA | R1-43 | | | | 40*7 |
| KUBOTA | R1-43 | | | | 42*7 |
| KUBOTA | R1-43 | 1番輸送軸 | No. 1Transit Shaft | 09500-25477 | 25*47*7 |
| KUBOTA | R1-43 | V2203DIC引擎曲軸 | V2203DIC EngineCrank Shaft | 19202-0414-0 | 42*55*9 |
| KUBOTA | R1-43 | V2203DIC引擎汽門 | V2203DIC Engine Valve | 15221-1315-0 | 8*13/15.3*7.5/10 |
| KUBOTA | R1-43 | 二號輸送軸 | No. 2 Transit Shaft | 09500-25458 | 25*45*8 |
| KUBOTA | R1-43 | 可動輪 | Carry Roller | 51601-1595-0 | 20*47*12/14 |
| KUBOTA | R1-43 | 可動輪座 | Equalizer | 09500-25356 | 25*35*6 |
| KUBOTA | R1-43 | 可動輪座(通用) | Equalizer | 52500-2195-0 | 25*35*7 |
| KUBOTA | R1-43 | 曲軸 | Crank Shaft | 19202-0446-0 | 85*102*12 |
| KUBOTA | R1-43 | 曲軸 | Crank Shaft | 04811-10300 | S30 |
| KUBOTA | R1-43 | 尾輪(改裝) | Idler (Alternated) | | 30*62*11/17 |
| KUBOTA | R1-43 | 尾輪(原裝型) 合體 | Idler (Original Type) | | 35*62*7/13 |
| KUBOTA | R1-43 | 尾輪(原裝型) 合體 | Idler (Original) | | 25*35*16 |
| KUBOTA | R1-43 | 型 | IdlerOriginal Type | | 28*62*11/17 |
| KUBOTA | R1-43 | 改) | Axle | | 35*72*12/14 |
| KUBOTA | R1-43 | 制限 | Limit | 04811-00060 | P6 |
| KUBOTA | R1-43 | 承油盤 | Oil Pan | 04811-00160 | P16 |
| KUBOTA | R1-43 | 承油盤 | Oil Pan | 17111-3641-0 | 檢油尺 |
| KUBOTA | R1-43 | 油箱內部2 | Oil Tank Inner 2 | 52791-1237-0 | 油封68 |

WLK Agriculture Machine Used Products.

DATE : 2014/01/03

| BRAND | MODEL | 用處 | APPLICATION | Part No. | Oil Seals Size |
|--------|-----------------|-----------|--------------------------------------|--------------|----------------|
| KUBOTA | R1-43 | 油箱內部3 | Oil Case Inner3 | 09500-30528 | 30*52*8 |
| KUBOTA | R1-43 | 氣缸頭蓋,油壓油箱 | Valve Cover , Hydraulic Oil Tank | 04811-50300 | G30 |
| KUBOTA | R1-43 | 無段變速油壓 | Non-Step Speed Changing Hydraulic | | 32*52*8 |
| KUBOTA | R1-43 | 補助輪 | Carry Roller | | 17*47*8 |
| KUBOTA | R1-43 | 補助輪 | Carry Roller | | 47/54*9.5 |
| KUBOTA | R1-43 | 滾輪 | Track Roller | | 25*62*11/16 |
| KUBOTA | R1-43 | 滾輪 | Track Roller | | 30*62*11/17 |
| KUBOTA | R1-43 | 滾輪(原裝型) | Track Roller (Original Type) | | 25*52*16 |
| KUBOTA | R1-43 | 滾輪(原裝型) | Track Roller (Original) | | 52*60*8.5 |
| KUBOTA | R1-43 | 齒輪箱 | Gear Box | 04811-00150 | P15 |
| KUBOTA | R1-43 | 齒輪箱 | Gear Box | 04811-00360 | P36 |
| KUBOTA | R1-43 | 變速箱內部1 | Speed Changing Case Inner1 | 09500-25478 | 25*47*8 |
| KUBOTA | R1-43 | 變速箱內部1 | Speed Changing Case Inner1 | 52500-1545-0 | 25*52*6 |
| KUBOTA | R1-43 | 變速箱內部2 | Speed Changing Case Inner2 | 52200-1567-0 | 20*30*7 |
| KUBOTA | R1-43 | 變速箱內部2 | Speed Changing Case Inner2 | 09504-06012 | 40*60*12 |
| KUBOTA | R1-43 | 變速箱外部 | Speed Changing Case Outer | 04815-50650 | G65 |
| KUBOTA | ROTOVATOR L2000 | | | AQ2693E | 40*75*14/17 |
| KUBOTA | RX2450D | 車軸(七齒) | Axle(7T) | | 35*72*20 |
| KUBOTA | RX2450D | 後輪 | Idler | | 35*72*14/19.5 |
| KUBOTA | RX2750D | | | 09500-20477 | 20*47*7 |
| KUBOTA | RX2750D | | | 09500-35528 | 35*52*8 |
| KUBOTA | RX2750D | 車心(牛腳) | Transmission Shaft | 58813-1645-0 | 40*80*12/18.5 |
| KUBOTA | RX2750D | 碗輪蓋 | Track Roller | | 55*70*10 |
| KUBOTA | RX2750D | 碗輪蓋 | Track Roller | | 55*70*8 |
| KUBOTA | RX2750D | 碗輪蓋 | Track Roller | | 45*55*27 |
| KUBOTA | RX2750D | 補助輪 | Carry Roller | | 17*35*12 |
| KUBOTA | RX2750D | 補助輪 | Carry Roller | 09500-17357 | 17*35*7 |
| KUBOTA | RX2750D | 補助輪上面 | Carry Roller Upper | | 35*42*10 |
| KUBOTA | RX2750D | 滾輪 | Track Roller | | 25*52*16 |
| KUBOTA | RX2750D | 滾輪 | Track Roller | AQ1749E | 30*62*11/17 |
| KUBOTA | RX2750D | 滾輪 | Track Roller | EZ2228A | 62/72*10/13 |
| KUBOTA | RX2750D | 滾輪(輪下) | Track Roller | | 52*60*8.5 |
| KUBOTA | RX2750D | 滾輪蓋 | Track Roller Cover | | 62*72*10 |
| KUBOTA | RX2750D/3550 | 補助輪 | Carry Roller | | 17*35*12 |
| KUBOTA | RX2750D/3550 | 補助輪 | Carry Roller | | 35*42*10 |
| KUBOTA | S 280 | 動力傳動部 | Power Transmission System | 09402-54707 | 25*47*7 |
| KUBOTA | S 280 | 插植部 | Planting Arm System | 09231-01425 | 10*14*2.5 |
| KUBOTA | S 280 | 插植部 | Planting Arm System | 41011-51612 | 16*28*6 |
| KUBOTA | S 280 | 傳動軸外蓋 | Transmission Shaft Cover | | 35*42*10 |
| KUBOTA | S 280 | 傳動箱內部 | Transmission Case Inner | 41011-41664 | 14*32*7.5 |
| KUBOTA | S 280 | 播手防泥 | Planting Arm Scraper | 41051-85512 | 8*18*7 |
| KUBOTA | S 280 | 播手防泥 | Planting Arm Scraper | 41051-85523 | 8*18*5.7 |
| KUBOTA | S 280 | 播手搖動軸 | Planting Arm Cam Push | BE3797 | 16*28*5.5/6.5 |
| KUBOTA | S 280 | 齒輪箱內部 | Gear Case Inner | 09502-54007 | 25*40*7 |
| KUBOTA | S 402 | | | | 47*54*9.5 |
| KUBOTA | S 402 | 合體 | | | 16*19*8 |

WLK Agriculture Machine Used Products.

DATE : 2014/01/03

| BRAND | MODEL | 用處 | APPLICATION | Part No. | Oil Seals Size |
|--------|--------------|-------------|---------------------------------------|--------------|----------------|
| KUBOTA | S 402 | 傳動箱內部 | Transmission Case Inner | | 17*35*9 |
| KUBOTA | S 402 | 新制成附帶 | Planting Arm Cam Push | 41011-41331 | 21*35/45*9 |
| KUBOTA | S 402 | 新制成附帶 | Planting Arm Cam Push | | 17*21*11.5 |
| KUBOTA | S 402 | 播手防泥 | Planting Arm Scraper | | 8*18*17 |
| KUBOTA | S 402 | 播手防泥(內部) | Planting Arm Scraper (Inner) | 41051-85512 | 8*18*7 |
| KUBOTA | S 402 | 播手防泥(外部) | Planting Arm Scraper (Outter) | | 8*18/26*16.5 |
| KUBOTA | S1-65 | | | | 8*14/20*7/15 |
| KUBOTA | S1-65 | 播手防泥(內部) | Planting Arm Scraper (Inner) | | 8*14*4 |
| KUBOTA | S1-65 | 輪軸 | Wheel Shaft | | 25*45*10 |
| KUBOTA | S1-650R | 35*39*18 SL | 35*39*18 SL | TCX439.52.11 | 35*52*11/18 |
| KUBOTA | S1-650R | 皮帶輪組 | Pulley Set | 45623-80160 | 40*50*4 |
| KUBOTA | S1-650R | 皮帶輪組 | Pulley Set | 45623-80340 | 45*55*4 |
| KUBOTA | S1-650R | 前輪軸 | Front Wheel Shaft | 44512-2397-0 | 25*47*12/14.8 |
| KUBOTA | S1-650R | 後輪軸 | Rear Wheel | 63733-1715-0 | 35*52/64*11/12 |
| KUBOTA | S1-6HD S1-65 | 單播手搖動軸 | Single Planting Arm Cam Shaft | | 28*8/11 |
| KUBOTA | S1-6HD S1-65 | 播手 | Planting Arm | | 8*18*7 |
| KUBOTA | S1-6HD S1-45 | 注油蓋(新型) | Oil Filling Cover (New) | | 12*17*11 |
| KUBOTA | S1-6HD(6行) | | | | 28*8/11 |
| KUBOTA | S1-6HD(6行) | 防泥(內) 6/4 | Scraper (Inner) 6/4 | 41051-8552-0 | 8*18*9 |
| KUBOTA | S1-6HD(6行) | 防泥(外) 6/4 | Scraper 6/4 | 41092-5137-0 | 8*18/26*16.5 |
| KUBOTA | S1-6HD(6行) | 播手軸 6/4 | Planting Arm Shaft 6/4 | 41332-5161-9 | 16*28*5.5/6.5 |
| KUBOTA | S1-800 | 送苗單向軸承 | Feeding Single way Bearing | | 16*22*3 |
| KUBOTA | S1-800R | 後輪 | Rear Wheel | | 40*52*5 |
| KUBOTA | S1-800R | 後輪 | Rear Wheel | | 40*52*7 |
| KUBOTA | S1-800RUDM | 前/後輪 | Front/Rear Wheel | AE2074E | 35*52/64*11/12 |
| KUBOTA | S1-800RUDM | 後傳動軸 | Rear Transmission Shaft | | 20*47*7 |
| KUBOTA | S1-800RUDM | 插植臂 | Planting Arm | AG0994E | 20*32*5 |
| KUBOTA | S1-800RUDM | 播手內部緩衝橡膠 | Planting Arm Inner Absorber | 45403-5157-0 | D 39 |
| KUBOTA | S1-800RUDM | 播手凸輪軸 | Planting Arm Cam Shaft | 45403-5159-0 | 12*28*7 |
| KUBOTA | S1-800RUDM | 播手防泥(內部) | Planting Arm Scraper (Inner) | 45403-5166-0 | 8*14*4 |
| KUBOTA | S1-800RUDM | 播手防泥(外部) | Planting Arm Scraper (Outter) | 45403-5164-2 | 8*14/20*7/15 |
| KUBOTA | S1-800RUDM | 播手注油塞(新型) | Planting Arm Oil Filling Cap (New) | | 12*17*11 |
| KUBOTA | S1-800RUDM | 播手旋轉軸 迴轉箱 | Planting Case Rotating Shaft | 45403-5128-0 | 20*35*5/7 |
| KUBOTA | S1-800RUDM | 播手旋轉軸 迴轉箱 | Planting Case Rotating Shaft | 45403-5129-0 | 25*40*6/8 |
| KUBOTA | SPA-85(D) | 送苗單向軸承 | Feeding Single way Bearing | | 16*22*3 |
| KUBOTA | SPA-85(D) | 迴轉箱 | Rotation Case | | 17*25*4 |
| KUBOTA | SPA85/SPA85D | 前輪站軸 | Front Wheel Vertical Shaft | | 60*68*5/6.5 |
| KUBOTA | SR75 | 1號輸送軸 | No. 1 Transit Shaft | 09500-30528 | 30*52*8 |
| KUBOTA | SR75 | 1號輸送軸,2號軸鏈箱 | No. 1 Feeding Shaft, No. 2 Chain Case | 09500-25477 | 25*47*7 |

WLK Agriculture Machine Used Products.

DATE : 2014/01/03

| BRAND | MODEL | 用處 | APPLICATION | Part No. | Oil Seals Size |
|---------|-------------------------------|-----------------|--|--------------|------------------|
| KUBOTA | SR75 | 2號軸鏈箱 | No. 2 Chain Case | 09500-25407 | 25*40*7 |
| KUBOTA | SR75 | 2號軸鏈箱 | No. 2 Chain Case | 09500-30478 | 30*47*8 |
| KUBOTA | SR75 | 2號輸送軸 | No. 2 Transit Shaft | 09500-22358 | 22*35*8 |
| KUBOTA | SR75 | 2號輸送軸 | No. 2 Transit Shaft | 09500-20358 | 20*35*8 |
| KUBOTA | SR75 | F2503TCC引擎汽門 | F2503TCC Engine Valve | 15221-1315-0 | 8*13/15.3*7.5/10 |
| KUBOTA | SR75 | F2503TCC引擎齒輪箱曲軸 | F2503TCC Engine Gear Case Crank Shaft | 19202-0414-0 | 42*55*9 |
| KUBOTA | SR75 | 分解HST泵(油泵) | HST(Oil Pump) | 58700-1129-0 | 25*40*7 |
| KUBOTA | SR75 | 可動轉輪(左) | Carry Roller (L) | 51601-1595-0 | 20*47*12/14 |
| KUBOTA | SR75 | 尾輪 | Idler | 51840-1563-2 | 30*72*14/16.3 |
| KUBOTA | SR75 | 卸穀機箱 | Deloading Case | 09500-25478 | 25*47*8 |
| KUBOTA | SR75 | 割刀曲柄 | Reaping Shaft | 59700-5836-0 | 47/56*5/18 |
| KUBOTA | SR75 | 割刀曲柄(左) | Reaping Shaft (Left) | 52500-2195-0 | 25*35*7 |
| KUBOTA | SR75 | 割取軸箱 | Reaping Shaft case | 09500-20407 | 20*40*7 |
| KUBOTA | SR75 | 傳動變速 | Transmission Speed Changing | 52270-1734-0 | 20*47*8 |
| KUBOTA | SR75 | 導輪 | Carry Roller | 52200-2333-0 | 20*42*9/12 |
| KUBOTA | SR75 | 機油箱內部油壓箱 | Oil Case Inner Hydraulic Case | 52200-1275-0 | 35*72*10 |
| KUBOTA | SR75 | 機油箱內部油壓箱 | Oil Tank inner Hydraulic case | 54617-2283-0 | 30*35*15 |
| KUBOTA | SR75 | 驅動皮帶輪 | Transmission Pulley | 09503-06210 | 30*62*10 |
| KUBOTA | SR75 | 變速箱內部(側離合器) | Speed Changing Case Inner(Side Clutch) | 09500-00025 | 17*30*6 |
| KUBOTA | SR75 | 變速箱內部(割取) | Speed Changing Case Inner(Reaping) | 52200-1542-0 | 28*47*8 |
| KUBOTA | ZB600/Z600/ ZB660 | | | | 58*72*9 |
| KUBOTA | 三輪車用 | | | | 坐椅 |
| LANDINI | | | | | 165*190*15/21 |
| LANDINI | " | 耕耘軸小 | Rotary Small | | 60*90*12/18 |
| LANDINI | 10000/13000/14500 | 前輪(2WD) | Front Wheel (2WD) | | 65*95*10 |
| LANDINI | 13000 /14000 | 前輪 | Front Wheel (4WD) | | 189*220*15/26 |
| LANDINI | 3095 / 5860 | 傳動 PTO 新型 | Transmission PTO New Type | | 50*78*10/17 |
| LANDINI | 58/68/88/98通用 | 前輪傳動傘型齒輪軸 | Front Wheel Transmission Bevel Gear Shaft | | 53*72*10 |
| LANDINI | 5830 | 耕耘軸大 | Rotary Big | AQ3563E | 72*100*13/17 |
| LANDINI | 5830/5860/8830/8860 | | | | 40*45*80 |
| LANDINI | 5830/5860/8830/8860 | 後輪 | Rear Wheel | | 浮動油封 |
| LANDINI | 5830/6830/8830 | 傳動 PTO 小型改良外面 | Transmission PTO Small Type Revised Outer | | 35*62*13/15.5 |
| LANDINI | 5830/6830/8830(4WD) | 傳動 PTO 舊型(標準型) | Transmission PTO Old Type (Standard Type) | | 50*70*10/17 |
| LANDINI | 5880/6880/8860/9880 Series | 車母PTO內新型 | PTO Inner New Type | | 50*75*9/17 |
| LANDINI | 5880/6880/8860/9880系 | 車母PTO外新型 | Type | AQ8305P | 45*70*12/17 |
| LANDINI | 5880/6880/8860/9880系 | 車母PTO外新型 | Type | | 35*45*17 |
| LANDINI | 6830/8830/4WD | 傳動 PTO 新型改良內面 | Transmission PTO New Type Revise Inner | | 50*75*9/17 |
| LANDINI | 8730/5830 | 前輪 | Front Wheel | 395527MI | 145*170*17/21.5 |
| LANDINI | 8830/8860/5830/5860/9880/5860 | 前輪 | Front Wheel | | 52*85*10 |

WLK Agriculture Machine Used Products.

DATE : 2014/01/03

| BRAND | MODEL | 用處 | APPLICATION | Part No. | Oil Seals Size |
|-----------------|-----------------------------|---------------|--------------------------------|----------|------------------|
| LANDINI | 8890/8860/9880 | 前輪轉向軸 | Front Wheel Steering Shaft | | P57*3.5 |
| LANDINI | 9880(4WD) | | | | 40*55*10 |
| LANDINI | 9880(4WD) | | | | 40*68*12 |
| LANDINI | 9880(4WD) | 前輪 | Front Wheel | | 45*68*12 |
| LANDINI | 9880(4WD) | 前輪 | Front Wheel | | 40*45*21 |
| LANDINI | 9880(舊型) | 後輪(舊型) | Rear Wheel(Old Type) | | 85*110*12/18 |
| LANDINI | 9880/8860 | 前輪 | Front Wheel | | 165*190*15/21 |
| LANDINI | 9880/8860 | 煞車 | Brake | | PL11 |
| LANDINI | 9880/8860(4WD) | 前輪(代用品) | Front Wheel (Replacement) | | 40*45*32 |
| LANDINI | 全車系通用 | 煞車 | Brake | | PL11 |
| Massey-Ferguson | 1114(4WD) | 前輪 | Front Wheel | | 170*200*15 |
| Massey-Ferguson | 1114/1134 | 前輪(2WD) | Front Wheel (2WD) | | 65*95*10 |
| Massey-Ferguson | 150/210HP(2WD) | 前輪橫軸 | Front Wheel Horizontal Shaft | (2WD) | 70*90*10 |
| Massey-Ferguson | 165/1114/1134/290/185 | 煞車 | Brake | | PL11 |
| Massey-Ferguson | 174,194 | 後輪 (舊型) | Rear Wheel (Old Type) | | 170*205*25/28 |
| Massey-Ferguson | 185/290/285/265165/1135 | 3821 | 3821 | | P 60 * 3.5 |
| Massey-Ferguson | 185/290/285/265165/1135 | 3822 | 3822 | | 四角型 P134*3.5 |
| Massey-Ferguson | 185/290/285/265165/1135 | 後傳動軸 | Rear Transmission Shaft | | 65*82*12 |
| Massey-Ferguson | 185/290/285/265165/1135 | 後傳動軸 | Rear Transmission Shaft | | 60*65*27.5 |
| Massey-Ferguson | 185/290/285/265165/1135 | 傳動 PTO | Transmission PTO | | 59*79.5*9.5 |
| Massey-Ferguson | 185/290/285/265165/1135 | 傳動 PTO (新型) | Transmission PTO (New Type) | | 60*79.5*12/20 |
| Massey-Ferguson | 185/290/295/285/265/165/135 | 後輪 | Rear Wheel | | 73*101.6*11.5/18 |
| Massey-Ferguson | 185/290/399/3095/265 | 前輪(2WD) | Front Wheel (2WD) | | 60*86*13 |
| Massey-Ferguson | 194 | 車母 PTO | PTO | | 35*62*13/15.5 |
| Massey-Ferguson | 194 | 前輪 內 (舊型) | Front Wheel Inner (Old Type) | | 40*55*7 |
| Massey-Ferguson | 194 | 前輪接頭 | Front Wheel Connector | 392108X1 | 35*50*7 |
| Massey-Ferguson | 194 | 前輪傳動軸 | Front Wheel Transmission Shaft | | 30*62*7 |
| Massey-Ferguson | 194 | 前輪傳動軸 | Front Wheel Transmission Shaft | | 45*72*10 |
| Massey-Ferguson | 194 265 | 前輪 | Front Wheel | 395521X1 | 145*170*17/21.5 |
| Massey-Ferguson | 194 399 | 後輪 (新型) | Rear Wheel (New Type) | | 189*220*15/26 |
| Massey-Ferguson | 194(4WD)290/265/ | 前輪 | Front Wheel | | 145*170*17/21.5 |
| Massey-Ferguson | 194,174 | 車母 PTO (舊型) | PTO (Old Type) | | 50*70*10/17 |
| Massey-Ferguson | 194/394/374 | 車母 PTO 外 | PTO Outer | AQ8305P | 45*70*12/17 |
| Massey-Ferguson | 194/394/374 | 車母 PTO 外 | PTO Outer | | 35*45*17 |
| Massey-Ferguson | 194/394/374/194/174 | 車母 PTO 內 (新型) | PTO Inner (New Type) | | 50*75*9/17 |
| Massey-Ferguson | 2095(4WD) | 前輪 | Front Wheel | | 189*220*15/26 |
| Massey-Ferguson | 2204 | 前輪 | Front Wheel | AQ8305P | 45*70*12 |
| Massey-Ferguson | 2204 | 前輪站軸 | Front Wheel Vertical Shaft | | 190*209*9.2 |
| Massey-Ferguson | 2204 | 耕耘軸大 | Rotary Big | | 50*76*8/16.5 |
| Massey-Ferguson | 2304 | 前輪 | Front Wheel | AQ8313P | 35*62*13/15.5 |
| Massey-Ferguson | 265 | 代用 | Replacement | | 44.45*63.5*12.7 |

WLK Agriculture Machine Used Products.

DATE : 2014/01/03

| BRAND | MODEL | 用處 | APPLICATION | Part No. | Oil Seals Size |
|-----------------|-------------------------------|-----------------------|--|---------------|-------------------|
| Massey-Ferguson | 265 | 後輪 (舊型) | Rear Wheel (Old Type) | | 170*205*25/28 |
| Massey-Ferguson | 265/3645/3655/3680/3690 | 後輪(外殼) 代用 | Rear Wheel | | 101.6*152.4*20 |
| Massey-Ferguson | 285 | 前輪車軸, 橫軸 | Front Wheel Axle, Horizontal Shaft | AQ8305P | 45*70*12/17 |
| Massey-Ferguson | 285 | 前擔輪 | Front Wheel | | P 190 * 2 |
| Massey-Ferguson | 285 | 後傳動 | Rear Transmission | | 35*72/80*13 |
| Massey-Ferguson | 285 | 後輪 | Rear Wheel | AQ8166P | 50*90*12/21 |
| Massey-Ferguson | 285 | 耕耘軸大 | Rotary Big | | 45*68*11/17 |
| Massey-Ferguson | 285 | 耕耘軸大(新型) | Rotary Big(New Type) | | 50*76*8/16.5 |
| Massey-Ferguson | 285 | 耕耘軸小 | Rotary Small | AQ2110E | 35*60*12/18 |
| Massey-Ferguson | 285 | 傳動 PTO | Transmission PTO | AQ8168P | 35*62*13/18 |
| Massey-Ferguson | 290 | (4WD)前輪 | (4WD)Front Wheel | | 145*170*17/21.5 |
| Massey-Ferguson | 3000 Series | 傳動 PTO | Transmission PTO | AQ3067E | 55*82*10.5/17 |
| Massey-Ferguson | 3000/3100/6140 | 傳動PTO | TransmissionPTO | AQ2881E | 50*78*10/17 |
| Massey-Ferguson | 3065(4WD) | 前輪(舊型)六支螺絲,(新型)一粒大螺絲母 | Front Wheel (Old Type) 6pcs Screw ,(New Type) 1pcs Big Screw Nuts | 194尾批車 | 165*190*15/21 |
| Massey-Ferguson | 3090 | 前輪 (新型) | Front Wheel (New Type) | | 189*220*15/26 |
| Massey-Ferguson | 3095 , MF151 | 傳動PTO | TransmissionPTO | 2-3330006140 | 50*78*10/17 |
| Massey-Ferguson | 3120 | 前輪 (新型) | Front Wheel (New Type) | | 189*220*15/26 |
| Massey-Ferguson | 3125(4WD) | 前輪 | Front Wheel | | 189*220*15/26 |
| Massey-Ferguson | 3250 | 前擔輪 | Front Wheel | | 48*70*12/17 |
| Massey-Ferguson | 3615/3125/3630/3095/3655/3680 | 後輪 | Rear Wheel | | 101.6*152.4*20 |
| Massey-Ferguson | 374(2WD)394 | 前輪 | Front Wheel | | 52*85*10 |
| Massey-Ferguson | 390/290 | (4WD)後輪 | (4WD)Rear Wheel | | 73*101.6*11.5/18 |
| Massey-Ferguson | 394F | 前輪傳動軸 | Front Wheel Transmission Shaft | | 35*52*8 |
| Massey-Ferguson | 394F | 前輪傳動軸(改裝1) | Front Wheel Transmission Shaft (Revised 1) | | 35*40*17 |
| Massey-Ferguson | 394F | 前輪傳動軸(改裝2) | Front Wheel Transmission Shaft(Alternated 2) | | 40*52*8 |
| Massey-Ferguson | 4050 | 前輪 舊型 | Front Wheel Old Type | M60X82X16 | 60*82*16 |
| Massey-Ferguson | 6140 | 前輪 | Front Wheel | | 165*190*15/21 |
| Massey-Ferguson | 6140(2WD) | 前輪橫軸 | Front Wheel Horizontal Shaft | | 60*86*13 |
| Massey-Ferguson | 8160 | 出力輪PTO | Output Wheel PTO | AQ2881E | 50*78*10/17 |
| Massey-Ferguson | PARKINGS Engine | 曲軸 SILICON | SILICON | | 133.85*158.7*12.7 |
| Massey-Ferguson | PARKINGS Engine | 曲軸 SILICON | SILICON | | 59.06*79.43*9.27 |
| MITSUBISHI | | | | | 加油線 Cable 8 尺 |
| MITSUBISHI | | P.T.O齒輪變速箱 2 | P.T.OGear Speed Changing Box 2 | 08300500100 | 10 ORING |
| MITSUBISHI | | 三菱(插) | Planter | BF3736E | 60*78*9/11 |
| MITSUBISHI | | 水平控制 1 | Horizontal Control 1 | 08300500600 | 60 ORING |
| MITSUBISHI | | 交叉進料 1 | Feeding 1 | 08300100070 | 7 ORING |
| MITSUBISHI | | 前輪 3 | Front Wheel 3 | 08300100630 | 63 ORING |
| MITSUBISHI | | 前輪 3 | Front Wheel 3 | 08300200700 | 70 ORING |
| MITSUBISHI | | 後輪 1 | Rear Wheel 1 | 08300500500 | 50 ORING |
| MITSUBISHI | | 後輪軸 5,指示器 2 | Rear Wheel 5, Indicator 2 | 0830-0100-200 | 20 ORING |
| MITSUBISHI | | 指示器 2 | Indicator 2 | 08300500120 | 12 ORING |

WLK Agriculture Machine Used Products.

DATE : 2014/01/03

| BRAND | MODEL | 用處 | APPLICATION | Part No. | Oil Seals Size |
|------------|-------------------|-----------------------|--|---------------|----------------|
| mitsubishi | | 動力方向機 2 | Power Steering 2 | 08300100220 | 22 ORING |
| mitsubishi | | 動力方向機 4 | Power Steering 4 | 08300100101 | 10 ORING |
| mitsubishi | | 液壓控制 1 | Hydraulic Control 1 | 08300100140 | 14 ORING |
| mitsubishi | | 插植迴轉臂 1 | Planting Rotative Arm 1 | 08300500220 | 22 ORING |
| mitsubishi | | 插植迴轉臂 2 | Planting Rotative Arm 2 | 08300500060 | 6 ORING |
| mitsubishi | | 插植箱 1 | Planting Case 1 | 8300100080 | 8 ORING |
| mitsubishi | | 無離合器控制 1,指示器 1,齒輪變速 2 | Non-Clutch Control 1, Indicator 1, Gear Speed Changing 2 | 08301100180 | 18 ORING |
| mitsubishi | | 齒輪變速 2 | Gear Speed Changing 2 | 08300100090 | 9 ORING |
| mitsubishi | 13H~26H | 耕耘軸小 | Rotary Small | | 30*62*16/18 |
| mitsubishi | 16HP(TT220)18HP | | | A932519N | 22*35*7 |
| mitsubishi | 16HP(TT220)18HP | | | H50011 | 20*40*7 |
| mitsubishi | 16HP(TT220)18HP | | | A932-519E | 30*50*11 |
| mitsubishi | 16HP(TT220)18HP | 曲軸 | Crank Shaft | | 52*75*12 |
| mitsubishi | 16HP(TT220)18HP | 尾輪 | Idler | | 15*35*11 |
| mitsubishi | 16HP(TT220)18HP | 車心(牛腳) | Transmission Shaft | A932538E | 45*62*5 |
| mitsubishi | 16HP(TT220)18HP | 車心(牛腳) | Transmission Shaft | | 45*62*9 |
| mitsubishi | 16HP(TT220)18HP | 車心(牛腳) | Transmission Shaft | A932522W | 45*62*12 |
| mitsubishi | 16HP(TT220)18HP | 車心(牛腳) | Transmission Shaft | | 40*45*32 |
| mitsubishi | 16HP(TT220)18HP | 耕耘軸 | Rotary | A932522W | 40*62*12 |
| mitsubishi | 16HP(TT220)18HP | 耕耘軸大接頭新式 | Rotary Big Connector New Type | | 45*62*9 |
| mitsubishi | 16HP(TT220)18HP | 耕耘軸大接頭新式 | Rotary Big Connector New Tyep | | 40*45*21 |
| mitsubishi | 16HP(TT220)18HP | 耕耘軸小 | Rotary Small | A9325-538E | 45*62*9 |
| mitsubishi | 16HP(TT220)18HP | 耕耘軸小 | Rotary Small | | 30*40*21 |
| mitsubishi | 16HP(TT220)18HP | 起動 | Starting | | 32*48*8 |
| mitsubishi | 16HP(TT220)18HP | 離合器 | Clutch | A923-523E | 30*52*5 |
| mitsubishi | 1900 | 滾輪 合體 | Track Roller | | 35*52*12 |
| mitsubishi | 1900 | 滾輪 合體 | Track Roller | | 25*35*22 |
| mitsubishi | 1900 2850 | 尾輪 合體 | Idler | | 35*52*12 |
| mitsubishi | 1900 2850 | 尾輪 合體 | IDLER | | 25*35*18 |
| mitsubishi | 20 HP | 耕耘軸 | Rotary | | 45*62*9 |
| mitsubishi | 20 HP | 耕耘軸(需修長度) | Rotary | | 40*45*30 |
| mitsubishi | 2201 | 耕耘軸大 | Rotary Big | | 55*85*13/19 |
| mitsubishi | 2201 | 耕耘軸小 | Rotary Small | | 38*65*14/17 |
| mitsubishi | 2204 | 耕耘軸小 | Rotary Small | AQ2110E | 35*60*12/18 |
| mitsubishi | 2204 | 傳動 PTO | Transmission PTO | AQ8168P | 35*62*13/18 |
| mitsubishi | 25 HP | 前輪 | Front Wheel | | 38*65*14/17 |
| mitsubishi | 26 HP | 輪軸 | Wheel Shaft | | 48*62*5 |
| mitsubishi | 26 HP | 輪軸 | Wheel Shaft | | 48*62*12 |
| mitsubishi | 26 HP | 輪軸 | Wheel Shaft | | 40*48*29.5 |
| mitsubishi | 2850 | 六齒車心 合體 | Transmission Shaft 6T | 0841-2406-215 | 40*62/72*13.5 |
| mitsubishi | 2850 | 六齒車心 合體 | Transmission Shaft 6T | | 30*40*18 |
| mitsubishi | 2850 | 曲軸 | Crank Shaft | | 70*92*12 |
| mitsubishi | 2850 | 尾輪 | Idler | BQ1577E | 25*62*10.5/17 |
| mitsubishi | 2850 | 車心新型 | Transmission Shaft New Type | | 30*62*12/18 |
| mitsubishi | 2850 | 後輪 合體 | Idler | | 35*52*12 |
| mitsubishi | 2850 | 滾輪 | Track Roller | BQ4096E | 25*52*11/18 |
| mitsubishi | 2850 | 滾輪 中輪 | Track Roller | | 25*52*12 |
| mitsubishi | 2850 5000 | 尾輪 | Idler | | 25*62*11/16 |

WLK Agriculture Machine Used Products.

DATE : 2014/01/03

| BRAND | MODEL | 用處 | APPLICATION | Part No. | Oil Seals Size |
|------------|-------------|--------------------------|---|---------------|----------------|
| mitsubishi | 2850 5000 | 尾輪 " | IDLER | | 25*35*16 |
| mitsubishi | 2850 5000 | 尾輪 合體 | Idler | | 35*62*7/13 |
| mitsubishi | 3201 | 軸 | Front Crank Shaft | AE2668U | 45*68*12 |
| mitsubishi | 3201/MT33 | 前擔輪 ? | Front Wheel | AQ8648E | 48*70*12/17 |
| mitsubishi | 3201無水平 | | | | 55*78*10 |
| mitsubishi | 3250 | 耕軸大/小, //4050傳動PTO //250 | Rotary Big/Small , 4050Transmission PTO //250 | AQ2881E | 50*78*10/17 |
| mitsubishi | 3250 | 傳動 PTO | Transmission PTO | AQ8313P | 35*62*12 |
| mitsubishi | 3250FD | 曲軸 | Crank Shaft | | 45*68*12 |
| mitsubishi | 3250FD | 油壓 | Hydraulic | | P 60 * 5.8 |
| mitsubishi | 3250FD | 前站輪 | Front Vertical Wheel | | 50*58*8 |
| mitsubishi | 3250FD | 前擔輪 | Front Wheel | AQ8648E | 48*70*12/17 |
| mitsubishi | 3250FD | 耕耘軸 大/小通用 | Rotary Big/ Small used | AQ2881E | 50*78*10/17 |
| mitsubishi | 3250FD | 傳動 PTO | Transmission PTO | AQ8313P | 35*62*13/15.5 |
| mitsubishi | 4050 | 油壓 | Hydraulic | | P 75 * 5.8 |
| mitsubishi | 4050 | 前輪 新 | Front Wheel New | 1181-2066-000 | 60*82*17/19 |
| mitsubishi | 4050 | 前輪(舊型) | Front Wheel (Old Type) | | 60*82*16 |
| mitsubishi | 4050 | 前輪//3201前輪站軸 | Front Wheel //3201Front Wheel Vertical Shaft | AE3193F | 60*75*9 |
| mitsubishi | 4050 | 前輪橫軸 新型 | Front Wheel Horizontal Shaft New Type | AQ7977P | 60*82*17/19 |
| mitsubishi | 4050 | 後輪 | Rear Wheel | | 70*95*13 |
| mitsubishi | 4050 | 後輪 | Rear Wheel | | 70*95*9 |
| mitsubishi | 4050 | 耕耘軸大,小 | Rotary Big, Small | AQ7242E | 60*90*12/18 |
| mitsubishi | 4050 | 傳動 PTO | Transmission PTO | | 55*70*10 |
| mitsubishi | 4050 | 煞車軸 | Brake Shaft | AE3222A | 60*82*12 |
| mitsubishi | 410 660/650 | | | | 8*18*17 |
| mitsubishi | 410 660/650 | 19-22播手防泥新型 | 19-22Planting Arm Scraper New Type | | 8*18/26*16.5 |
| mitsubishi | 4250 | 滾輪(原裝型) | Track Roller (Original Type) | | 25*52*16 |
| mitsubishi | 4501 | 前輪站軸 | Front Wheel Vertical Shaft | | 60*75*9 |
| mitsubishi | 4501 | 前輪橫軸 | Front Wheel Horizontal Shaft | AQ3225F | 60*82*17/19 |
| mitsubishi | 4501 | 耕耘軸大 | Rotary Big | AQ3074E | 55*85*13/19 |
| mitsubishi | 4501 2501 | 耕耘軸小 | Rotary Small | AQ7963P尾批車 | 38*65*14/17 |
| mitsubishi | 4501(有水平) | 耕耘軸大 | Rotary Big | 705365-5131 | 55*82*10.5/17 |
| mitsubishi | CA32 | 補助輪 | Carry Roller | | 28*47*8 |
| mitsubishi | CA32 | 補助輪 | Carry Roller | | 20*28*11 |
| mitsubishi | MC42 | | | | 35*40*17 |
| mitsubishi | MC42 | 尾輪 (菱祥) | Idler | 35212261000 | 30*72*12/17 |
| mitsubishi | MC42 | 補助輪 | Carry Roller | | 15*35*7 |
| mitsubishi | MC42 | 滾輪 | Track Roller | BQ4096E | 25*52*11/18 |
| mitsubishi | MC42 , 45 | 尾輪 | Idler | | 40*72*12 |
| mitsubishi | MC42 , 45 | 尾輪 | IDLER | | 30*40*19 |
| mitsubishi | MC42/MC45 | 七齒車軸 | 7T Axle | | 50*72*12 |
| mitsubishi | MC45 | 滾輪 | Track Roller | AQ8313P | 35*62*13/15.5 |
| mitsubishi | MC5000 | 七齒車心 | Transmission Shaft 7T | | 35*72*20 |
| mitsubishi | MC5000 | 滾輪 | Track Roller | | 25*62*11/16 |

WLK Agriculture Machine Used Products.

DATE : 2014/01/03

| BRAND | MODEL | 用處 | APPLICATION | Part No. | Oil Seals Size |
|------------|----------------|-------------------|---------------------------------------|---------------|----------------|
| MITSUBISHI | MC5000 | 滾輪 合體 | Track Roller | | 35*62*7/13 |
| MITSUBISHI | MC5000 | 滾輪 合體 | Track Roller | | 25*35*16 |
| MITSUBISHI | MC5000 45, 486 | 尾輪 (菱祥) | Idler | 3515-1519-000 | 35*72*12/22 |
| MITSUBISHI | MC5000 , 45 | 六齒車心(菱祥) | Transmission Shaft 6T | 3521-2302-200 | 30*72*12/17 |
| MITSUBISHI | MC5000改裝用 | 七齒車軸 | 7T Axle | | P 35 * 3 (G35) |
| MITSUBISHI | MC65 | 滾輪 | Track Roller | 3559-2257-000 | 46*66*20 HDDF |
| MITSUBISHI | MP410C | 16-5 (MP660 19-4) | 16-5 (MP660 19-4) | 0840-1015-307 | 15*30*7 |
| MITSUBISHI | MP410C | 19-21 | 19-21 | 0840-1012-309 | 12*30*9 |
| MITSUBISHI | MP410C | 19-32 | 19-32 | 0840-1015-329 | 15*32*9 |
| MITSUBISHI | MP410C | 19-51播手防泥(外) | 19-51Planting Arm Scraper (Outer) | 2761-3727-000 | 8*18*5.7 |
| MITSUBISHI | MP410C | 19-52播手防泥(內) | 19-52Planting Arm Scraper (Inner) | 2761-3728-000 | 8*18*7 |
| MITSUBISHI | MP410C | 22-7 | 22-7 | 0840-1012-257 | 12*25*7 |
| MITSUBISHI | MP410C | 5-7 | 5-7 | 0840-1020-328 | 20*32*8 |
| MITSUBISHI | MP410C | 6-16 | 6-16 | 2772-1259-000 | 25*52*12 |
| MITSUBISHI | MP410C | 8-16 | 8-16 | 0840-0014-245 | 14*24*5 |
| MITSUBISHI | MP60/MP40 | 水平軸 | Horizontal Shaft | | 22*28*4 |
| MITSUBISHI | MP-601行走式 | 輪軸 | Wheel Shaft | | 52*62*8 |
| MITSUBISHI | MP660 | 播手防泥(內) | Planting Arm Scraper(Inner) | | 8*18*9 |
| MITSUBISHI | MP660 | 19-4 播手 | 19-4 Planting Arm | 0840-1015-307 | 15*30*7 |
| MITSUBISHI | MP660 | 608-31 播手防泥(外) | 608-31 Planting Arm Scraper (Outer) | | 8*18*17 |
| MITSUBISHI | MP660 | 輪仔包用 輪軸 | Wheel Shaft | | 25*40*12 |
| MITSUBISHI | MP660/MP600 | 前輪軸 | Front Wheel Shaft | | 25*40*12 |
| MITSUBISHI | MPR605 | P.T.O齒輪變速箱 2 | P.T.O Gear Speed Changing Case 2 | 27571411000 | 20*42*8 |
| MITSUBISHI | MPR605 | 引擎 | Engine | 54610034000 | 8*14*5 |
| MITSUBISHI | MPR605 | 曲軸 | Crank Shaft | 54610033000 | 35*52*8 |
| MITSUBISHI | MPR605 | 後輪 2,動力方向機 2 | Rear Wheel 2,Power Steering 2 | 08401020428 | 20*42*8 |
| MITSUBISHI | MPR605 | 後輪 3 | Rear Wheel 3 | 08412356212 | 35*62*12 |
| MITSUBISHI | MPR605 | 後輪 4 | Rear Wheel 4 | | 40*62/72*13.5 |
| MITSUBISHI | MPR605 | 後輪 4 | Rear Wheel 4 | | 35*40*17 |
| MITSUBISHI | MPR605 | 後輪 5,差速控制 2 | Rear Wheel 5,differential Conductor 2 | 08401020307 | 20*30*7 |
| MITSUBISHI | MPR605 | 插植迴轉臂 3 | Planting Arm 3 | 27564606000 | 25*35*6 |
| MITSUBISHI | MPR605 | 傳動齒輪變速箱 | Transmission Gear Speed Changing Box | 08340047080 | 47*8 |
| MITSUBISHI | MPR605 | 齒輪箱 | Gear Case | 54610302000 | 30*46*8 |
| MITSUBISHI | MPR605 | 驅動箱 4 | Transmission Case 4 | 08401012257 | 12*25*7 |
| MITSUBISHI | MPR605/MP410C | 液壓線 | Hydraulic System | 08401017357 | 17*35*7 |
| MITSUBISHI | MPR605/MP410C | 幫浦 | Pump | 08401012227 | 12*22*7 |
| MITSUBISHI | MPR65H | | | | 15*30*7 |
| MITSUBISHI | MPR65H | 前輪站軸 | Front Wheel Vertical Shaft | BE3736E | 60*78*9/11 |
| MITSUBISHI | MPR65H | 後輪軸 5 | Rear Wheel Shaft 5 | | 20*30*7 |

WLK Agriculture Machine Used Products.

DATE : 2014/01/03

| BRAND | MODEL | 用處 | APPLICATION | Part No. | Oil Seals Size |
|------------|-----------------|-----------------------|---|---------------|----------------|
| MITSUBISHI | MPR65H | 插植迴轉臂 3 | Planting Arm 3 | | 25*35*6 |
| MITSUBISHI | MPR805 | 後輪 1 | Rear Wheel 1 | 08331001000 | M10 WASHER |
| MITSUBISHI | MPR805 | 後輪 2 | Rear Wheel 2 | 08401020428 | 20*42*8 |
| MITSUBISHI | MPR805 | 後輪軸 4 | Rear Wheel Shaft 4 | 08412356212 | 35*62*12 |
| MITSUBISHI | MPR805 | 後輪軸 5 | Rear Wheel Shaft 5 | 08401020307 | 20*30*7 |
| MITSUBISHI | MPR805 | 動力方向機 3 | Power Steering 3 | 08340047080 | 47*8 |
| MITSUBISHI | MPR805 | 插植迴轉臂 1 | Planting Arm 1 | 27564606000 | 25*35*6 |
| MITSUBISHI | MPR805 | 傳動齒輪變速箱 2 | Transmission Gear Speed Changing Case 2 | 27571411000 | 20*42*8 |
| MITSUBISHI | MPR805 | 齒輪箱 | Gear Case | 54610033000 | 35*52*8 |
| MITSUBISHI | MPR805(全車系) | 前輪 2(25*40*12 TC6Y代用) | Front Wheel 2(25*40*12 TC6YReplacement) | 27481639000 | 25*40*12 |
| MITSUBISHI | MPR805/MPR605 | 後輪 1 | Rear Wheel 1 | 08340020070 | 20*7 |
| MITSUBISHI | MPR805/MPR605 | 傳動齒輪變速箱 | Transmission Gear Speed Changing Case | 08401020358 | 20*35*8 |
| MITSUBISHI | MPR85H/MPR65H | 後輪軸 | Rear Wheel Shaft | | 35*62*13/15.5 |
| MITSUBISHI | MT 5201/4501 | 前輪(曳) | Front Wheel | | 60*82*17/19 |
| MITSUBISHI | MT16T | 耕耘軸大 | Rotary Big | | 55*82*10 |
| MITSUBISHI | MT2501 | | | | 35*52/64*11/12 |
| MITSUBISHI | MT2501 | 前輪 | Front Wheel | BQ4096E | 25*52*11/18 |
| MITSUBISHI | MT2501 | 前輪軸公司改 | Front Wheel Shaft | 0841-2355-212 | 35*52*11/18 |
| MITSUBISHI | MT33HP /30 | 耕耘軸大 | Rotary Big | AQ3067E | 55*82*10.5/17 |
| MITSUBISHI | MT33HP /30 | 耕耘軸小 | Rotary Small | AQ7963P | 38*65*14/17 |
| MITSUBISHI | TRP-4AS | | | | 8*18*5.7 |
| MITSUBISHI | TRP-4AS | 播手爪 | Planting Arm Scraper | | 8*18*7 |
| MITSUBISHI | VG65 | 七齒車軸 | 7T Axle | | 50*72*9 |
| MITSUBISHI | VG65 | 七齒車軸 | 7T Axle | | 45*75*14/17 |
| MITSUBISHI | 菜園 | 耕耘軸 | Rotary | | 65*95*11/18 |
| NIPLO 松山 | | | | | 45*62*12 |
| NIPLO 松山 | | 入力軸PTO | Intake ShaftPTO | | 40*62*16 |
| NIPLO 松山 | | 耕耘軸小 | Rotary Small | 1261111000B | 55*82*10.5/17 |
| NIPLO 松山 | | 耕耘軸小 | Rotary Small | AQ7320E | 60*95*12/19 |
| NIPLO 松山 | | 耕耘軸小蓋子 | Rotary Small Cap | | S100(99.5*2) |
| NIPLO 松山 | | 耕耘軸小蓋子 | Rotary Small Cap | | S110(109.5*2) |
| NIPLO 松山 | " | 耕耘軸大 | Rotary Big | 1331129000B | 60*90*12/18 |
| NIPLO 松山 | " | 耕耘軸大 | Rotary Big | 1172122000B | 65*95*11/18 |
| NIPLO 松山 | " | 耕耘軸大,小 | Rotary Big, Small | 0210681018B | 65*100*11/18 |
| NIPLO 松山 | " | 耕耘軸小 | Rotary Small | AQ2688E | 45*72*13/20 |
| NIPLO 松山 | " N 新型 | 耕耘軸大 | Rotary Big | AQ8177E | 60*90*10/17 |
| NIPLO 松山 | " N 新型 | 耕耘軸小 | Rotary Small | | 55*82*10.5/17 |
| NIPLO 松山 | 1700/1800 | 入力軸 PTO | Intake Shaft PTO | 0250355511 | 35*55*11 |
| NIPLO 松山 | 用 | 耕耘軸大 | Rotary Big | 1261111000B | 55*82*10.5/17 |
| NIPLO 松山 | 1800N(A)/1800N | 入力軸 PTO | Intake Shaft PTO | 0250406211B | 40*62*12 |
| NIPLO 松山 | 2000N/1900N(A) | 入力軸 PTO | Intake Shaft PTO | 0250406211B | 40*62*12 |
| NIPLO 松山 | 2300(V) 2400(V) | 橫向傳動軸 | Horizontal Transmission Shaft | 0260709007B | 70*92*7 |
| NIPLO 松山 | 2300N/2200N | 入力軸 PTO | Intake Shaft PTO | 0250406211B | 40*62*11 |
| NIPLO 松山 | 2400N | 橫向傳動軸 | Horizontal Transmission Shaft | 0260709207B | 70*92*7 |
| NIPLO 松山 | 95年 | 耕耘軸小 | Rotary Small | AQ7242E | 60*90*12/18 |
| NIPLO 松山 | CX/MX/LX通用 | 耕耘軸小 | Rotary Small | 0210457132 | 45*72*13/20 |
| NIPLO 松山 | DC2300 | 耕耘軸大 | Rotary Big | | 75*110*23/25 |
| NIPLO 松山 | DC2300 | 耕耘軸小 | Rotary Small | | 60*92*22 |
| NIPLO 松山 | DX | 代用 | Replacement | | P190*2.0 |

WLK Agriculture Machine Used Products.

DATE : 2014/01/03

| BRAND | MODEL | 用處 | APPLICATION | Part No. | Oil Seals Size |
|-------------|----------------------------|-------------|---|-------------|-----------------|
| NIPLO 松山 | DX | 耕耘軸鏈側板 | Rotary Chain Side Cover | | S135 |
| NIPLO 松山 | DX | 橫向傳動軸 | Horizontal Transmission Shaft | | P200*2.0 |
| NIPLO 松山 | DX 2.2M | 耕耘軸小 | Rotary Small | 1331142000B | 45*72*13/20 |
| NIPLO 松山 | DX 2200(V) | 入力軸 PTO | Intake Shaft PTO | 0250406211B | 40*62*11 |
| NIPLO 松山 | DX 2201N(95年),6310 新型重型 | 耕耘軸大 | Rotary Big | AQ8178P | 75*110*12/20 |
| NIPLO 松山 | DX 2400 新型 | 耕耘軸小 | Rotary Small | AQ7242E | 60*90*12/18 |
| NIPLO 松山 | DX2.4M | 耕耘軸小 | Rotary Small | | 45*72*13/20 |
| NIPLO 松山 | DX2.4米 | 耕耘軸小 | Rotary Small | | 45*72*13/20 |
| NIPLO 松山 | DX2201N(同FX) | 耕耘軸小 | Rotary Small | 1331129000 | 60*90*12/18 |
| NIPLO 松山 | EX2500NV | 入力軸 PTO | Intake Shaft PTO | 0250456209 | 45*62*9 |
| NIPLO 松山 | EX2501N(1000轉(3軸)) | 耕耘軸大 | Rotary Big | 1501120000 | 75*110*12/20 |
| NIPLO 松山 | HA1800(B)2000(B) | 入力軸 PTO | Intake Shaft PTO | 0250406211C | 40*62*11 |
| NIPLO 松山 | LE 2100NF | 入力軸 PTO | Intake Shaft PTO | 0250406211B | 40*62*11 |
| NIPLO 松山 | N→PTO 540轉(2 軸) | 耕耘軸大 | Rotary Big | 1501120000B | 75*110*12/20 |
| NIPLO 松山 | PE1600/PE1900 | 入力軸 PTO | Intake Shaft PTO | 0240456812B | 45*68*12 |
| NIPLO 松山 | SX 1500/1600 | 輪軸 | Wheel Shaft | 0250032528 | 32*52*8 |
| NIPLO 松山 | SX1500NA1600NA | 入力軸 PTO | Intake Shaft PTO | 0250355511B | 35*55*11 |
| NIPLO 松山 | 舊型輕型 | 耕耘軸大 | Rotary Big | AQ3563E | 72*100*13/17 |
| SAME | 100/110 | 後輪 | Rear Wheel | | 85*110*12 |
| SAME | 100LASER | 後輪(改裝) | Rear Wheel(Alternated) | | 130*160*15 |
| SAME | 110 | 後輪 | Rear Wheel | | 145*170*17/21.5 |
| SAME | 110HP/100 | 傳動PTO | TransmissionPTO | AQ8124 | 85*110*12/18 |
| SAME | 150 | 後輪 | Rear Wheel | | 145*170*17/21.5 |
| SAME | 150原裝 | CORTECO | CORTECO | | 140*170*15 |
| SAME | 2WD | 前輪橫軸(曳) | Front Wheel Horizontal Shaft | | 65*90*13 |
| SAME | 60 | 前輪 | Front Wheel | 395527MI | 145*170*17/21.5 |
| SAME | 60 | 前輪軸 | Front Wheel Shaft | AE2651E | 45*62*9 |
| SAME | 80 | 後輪 | Rear Wheel | | 75*110*12/16.5 |
| SAME | 80 | 後輪內部 | Rear Wheel Inner | | 60*85*10 |
| SHIBAURA 芝浦 | | | | | 40*65*9 |
| SHIBAURA 芝浦 | | 後輪 | Rear Wheel | | 70*95*17 |
| SHIBAURA 芝浦 | 25 HP | 油壓 | Hydraulic | | P 62 * 5.6 |
| SHIBAURA 芝浦 | 25 HP | 油壓 大 | Hydraulic Big | | P 62 * 5.3 |
| SHIBAURA 芝浦 | 25 HP | 油壓 小 | Hydraulic Small | | P 58 * 6.3 |
| SHIBAURA 芝浦 | 25 HP | 後輪 | Rear Wheel | | 52*75*16 |
| SHIBAURA 芝浦 | 25 HP | 耕耘軸大 | Rotary Big | BQ1100E | 55*80*13/18 |
| SHIBAURA 芝浦 | 25 HP | 耕耘軸大 | Rotary Big | BQ1100EO | 55*80*13/18 |
| SHIBAURA 芝浦 | 25 HP | 耕耘軸小 | Rotary Small | | 40*75*14/17 |
| SHIBAURA 芝浦 | 28HP | 耕耘軸小 | Rotary Small | | 60*90*12/18 |
| SHIBAURA 芝浦 | 3040新型 | 後輪 | Rear Wheel | AQ7549P | 55*80*13/18 |
| SHIBAURA 芝浦 | 31 HP | 耕耘軸 | Rotary | | 45*75*14/17 |
| SHIBAURA 芝浦 | 32 HP | 後輪 | Rear Wheel | | 55*80*13/18 |
| SHIBAURA 芝浦 | 4000 | 曲軸,時規蓋 | Crank Shaft , Timing Cover | AE2369E | 40*58*8 |
| SHIBAURA 芝浦 | 4000 | 前輪/D28F前輪橫軸 | Front Wheel /D28FFront Wheel Horizontal Shaft | M52X75X15 | 52*75*15 |
| SHIBAURA 芝浦 | 4000 | 耕耘軸大舊型 | Rotary Big Old Type | AQ2890E | 50*80*10 |
| SHIBAURA 芝浦 | 4000(40HP) | 曲軸 | Crank Shaft | | 50*72*12 |
| SHIBAURA 芝浦 | 4000(40HP) | 曲軸小 | Crank Shaft Small | AE2369E | 40*58*8 |
| SHIBAURA 芝浦 | 4000(40HP) | 前輪 | Front Wheel | | 52*75*16 |
| SHIBAURA 芝浦 | 4000(40HP) | 後傳動 PTO | Rear Transmission PTO | | 35*55*11 |
| SHIBAURA 芝浦 | 4000(40HP) | 後輪 | Rear Wheel | | 65*90*17/18 |

WLK Agriculture Machine Used Products.

DATE : 2014/01/03

| BRAND | MODEL | 用處 | APPLICATION | Part No. | Oil Seals Size |
|-------------|------------------------------|---------------|---|-----------------|-----------------|
| SHIBAURA 芝浦 | 4000(40HP) | 耕耘軸大,小(新型) | Rotary Big, Small(New Type) | | 60*90*10/17 |
| SHIBAURA 芝浦 | 4000(40HP) | 耕耘軸小 舊型 | Rotary Small Old Type | AQ7242P,AQ8177P | 60*90*10/17 |
| SHIBAURA 芝浦 | 4000(40HP) | 起動 | Starting | | 40*58*8 |
| SHIBAURA 芝浦 | 4000(40HP) | 傳動 PTO | Transmission PTO | | 40*62*12 |
| SHIBAURA 芝浦 | 4000(40HP) | 傳動 PTO | Transmission PTO | | 35*40*17 |
| SHIBAURA 芝浦 | 40HP | 曲軸後油封 | Crank Shaft Rear | AE2864A | 50*72*12 |
| SHIBAURA 芝浦 | 40HP | 傳動PTO | TransmissionPTO | AE2085E | 35*55*11 |
| SHIBAURA 芝浦 | 445(40HP) | 前輪站軸 | Front Wheel Vertical Shaft | | 55*78*16 |
| SHIBAURA 芝浦 | 45/50/53 HP | 耕耘軸大 | Rotary Big | AQ8673P | 65*100*12 |
| SHIBAURA 芝浦 | 53/63 | 前送 | Front Transmission | AE1679H | 30*45*8 |
| SHIBAURA 芝浦 | 53HP | 曲軸後 | Crank Shaft Rear | AE3204E | 60*78*9 |
| SHIBAURA 芝浦 | 63/83 | 曲軸後 | Crank Shaft Rear | AE3618A | 75*100*13 |
| SHIBAURA 芝浦 | 83HP | 前驅軸(後) | F/W Shaft(Rear) | | 40*62*12 |
| SHIBAURA 芝浦 | 83HP(8340) | 前曲軸 | Front Crank Shaft | AH3618H | 75*100*13 |
| SHIBAURA 芝浦 | D28F | 前輪橫軸 | Front Wheel Horizontal Shaft | | 52*75*16 |
| SHIBAURA 芝浦 | M4000DT,L2000,25HP | 耕耘軸大 | Rotary Big | AQ2427E | 40*75*14/17 |
| SHIBAURA 芝浦 | SE5340(53HP) | 前輪 | Front Wheel | AQ8251P | 115*145*12.5*24 |
| SHIBAURA 芝浦 | SE5340(53HP) | 前輪,前輪驅動軸(後) | Front Wheel ,Front Wheel Transmission Shaft(Rear) | | 100*125*17 |
| SHIBAURA 芝浦 | SE5340(53HP) | 前輪驅動軸(前) | Front Wheel Transmission Shaft | | 70*95*17 |
| SHIBAURA 芝浦 | SE5340(53HP) | 後輪 | Rear Wheel | | 70*95*12/18 |
| SHIBAURA 芝浦 | SE5340(53HP) | 耕耘軸大 | Rotary Big | AQ8673P | 65*100*12/19 |
| SHIBAURA 芝浦 | SE5340(53HP) | 耕耘軸小 | Rotary Small | AQ7242E | 60*90*12/18 |
| SHIBAURA 芝浦 | SE5340/SE5346/SE6340/73(4WD) | 前輪 | Front Wheel | AQ8251P | 115*145*12.5/24 |
| SHIBAURA 芝浦 | SE5346(53HP) | 引擎曲軸 | EngineCrank Shaft | | 60*78*9 |
| SHIBAURA 芝浦 | SE5346(53HP) | 前驅支架 | Front Transmission Supporting-Arm | | 70*95*17 |
| SHIBAURA 芝浦 | SE5346(53HP) | 後輪輪軸 | Rear Wheel Wheel Shaft | | 70*95*17 |
| SHIBAURA 芝浦 | SE5346(53HP) | 耕耘軸大 (4WD) | Rotary Big (4WD) | | 65*100*12/19 |
| SHIBAURA 芝浦 | SE5346(53HP) | 耕耘軸小 | Rotary Small | | 60*90*12/18 |
| SHIBAURA 芝浦 | SE5346(53HP) | 離合器後軸 | Clutch Rear Shaft | | 40*52*8 |
| SHIBAURA 芝浦 | SE6340(63HP) | 引擎曲軸 (HTBL) | EngineCrank Shaft (HTBL) | AH7513P | 110*135*13 |
| SHIBAURA 芝浦 | SE6340(63HP) | 前輪 | Front Wheel | AQ8251P | 115*145*12.5*24 |
| SHIBAURA 芝浦 | SE6340(63HP) | 耕耘軸大 | Rotary Big | | 72*100*13/17 |
| SHIBAURA 芝浦 | SE6340(63HP) 28 HP | 耕耘軸小 | Rotary Small | | 60*90*12/18 |
| SHIBAURA 芝浦 | SE8340 | 引擎前曲軸 | Engine Front Crank Shaft | AH3618H | 75*100*13 |
| SHIBAURA 芝浦 | SE8340 | 曲軸(後) | Crank Shaft (Rear) | AH7513 | 110*135*13 |
| SHIBAURA 芝浦 | SE8340(83HP) | 耕耘軸小 | Rotary Small | | 60*92*22 |
| SHIBAURA 芝浦 | V 80F | 傳動 PTO | Transmission PTO | | 35*65*9/15.5 |
| SHIBAURA 芝浦 | V52 | 耕耘軸大 | Rotary Big | | 60*90*10/17 |
| SHIBAURA 芝浦 | V52 | 耕耘軸小 | Rotary Small | | 45*72*13/20 |
| SHIBAURA 芝浦 | V52F(4WD) | 前輪 舊型 | Front Wheel Old Type | 9031130115 | 60*82*16 |
| SHIBAURA 芝浦 | V52F(4WD) | 前輪站軸 | Front Wheel Vertical Shaft | | 55*78*16 |
| SHIBAURA 芝浦 | V52F(4WD) | 後輪 | Rear Wheel | | 70*95*12/18 |
| SHIBAURA 芝浦 | V52F(4WD) | 輪軸 ?2095.12前輪 | Wheel Shaft ?2095.12Front Wheel | | 60*82*17/19 |

WLK Agriculture Machine Used Products.

DATE : 2014/01/03

| BRAND | MODEL | 用處 | APPLICATION | Part No. | Oil Seals Size |
|-------------|-----------------------------|---------------------|-----------------------------------|--------------------|------------------|
| SHIBAURA 芝浦 | V52F(4WD) 45HP | 前輪 ?60X82X12 | Front Wheel ?60X82X12 | | 65*95*11/18 |
| SHIBAURA 芝浦 | V70 | 前輪站軸 | Front Wheel Vertical Shaft | | 60*82*16 |
| SHIBAURA 芝浦 | V80F | 後輪 | Rear Wheel | | 70*95*17 |
| STAR 星牌 | 1807/2007 | 耕耘軸大 | Rotary Big | AQ7534P | 75*105*12.5*18.5 |
| STAR 星牌 | 1808/2008 | 中型耕耘軸小 | Rotary Small | AQ7320E | 60*95*12/19 |
| STAR 星牌 | 1900 | 耕耘軸大 | Rotary Big | AQ7534P | 75*105*12.5*18.5 |
| STAR 星牌 | 1900(中型) | 耕耘軸小 | Rotary Small | AQ7320E | 60*95*12/19 |
| STAR 星牌 | RFT 2008/ 2609/2308 | 耕耘軸大 | Rotary Big | QLF75110125 205 | 75*110*12/20 |
| STAR 星牌 | RFT 2008/2308 | 耕耘軸小 | Rotary Small | QLF60901219 5 | 60*90*12/18 |
| STAR 星牌 | RFT 2609 | 入力軸 PTO | Intake Shaft PTO | PJ406211 | 40*62*11 |
| STAR 星牌 | RFT 2609 | 輪軸 | Wheel Shaft | 34206 | 35*55*11 |
| STAR 星牌 | RFT2008/2308 | 入力軸 PTO | Intake Shaft PTO | PJ406211 | 40*62*11 |
| STAR 星牌 | RFT2008/2308 | 輪軸 | Wheel Shaft | 34206 | 35*55*11 |
| STAR 星牌 | RHT 1807 | 橫向傳動軸 | Horizontal Transmission Shaft | PJ659013 | 65*90*13 |
| STAR 星牌 | RHT 1807/ 2008/2508/2308 | 耕耘軸小 | Rotary Small | QLF60951219 5 | 60*95*12/19 |
| STAR 星牌 | RHT 2008/ 2308 /2508 | 橫向傳動軸 | Horizontal Transmission Shaft | PJ709513 | 70*95*13 |
| STAR 星牌 | RHT 2309/ 2509 /2609 | 耕耘軸大 | Rotary Big | QLF75110125 205 | 75*110*12/20 |
| STAR 星牌 | RHT1807/2008/2308/25 08 | 入力軸 PTO | Intake Shaft PTO | PJ406211 | 40*62*11 |
| STAR 星牌 | 中型 | 耕耘軸大 | Rotary Big | AQ7534P | 75*105*12.5*18.5 |
| STEYR | 8090 | 前輪(12支螺絲)(不 用外套) | Front Wheel (12pcs Screw Nuts) | | 165*190*15/21 |
| TA SOON 大順 | | | | | 12*32*7 |
| TA SOON 大順 | | | | | 20*34*7 |
| TA SOON 大順 | | | | | 15*35*4 |
| TA SOON 大順 | | | | | 25*35*5 |
| TA SOON 大順 | | | | | 20*40*8 |
| TA SOON 大順 | | | | | 17*40*8 |
| TA SOON 大順 | | | | | 25*45*10 |
| TA SOON 大順 | | | | | 20*47*10 |
| TA SOON 大順 | | | | | 30*50*11 |
| TA SOON 大順 | | | | | 35*55*5 |
| TA SOON 大順 | | | | | 45*62*9 |
| TA SOON 大順 | | | | | 42*65*9 |
| TA SOON 大順 | | | | | 50*70*10 |
| TA SOON 大順 | | | | | 35*72/80*13 |
| TA SOON 大順 | | | | | 30*72*11 |
| TA SOON 大順 | | | | | 30.5 |
| TA SOON 大順 | | | | 600-02110- 000 | 5*14.5*22 |
| TA SOON 大順 | | | | | P 10 * 2 |
| TA SOON 大順 | | | | | P 15 * 2.5 |
| TA SOON 大順 | | | | | P 8 * 2 |
| TA SOON 大順 | | | | | P 9 * 2 |
| TA SOON 大順 | | | | | P 9.8 * 2.4 |
| TA SOON 大順 | | KE 型主齒輪箱 | KE Type Main Gear Box | P10 | P10 |
| TA SOON 大順 | | KE 型主齒輪箱 | KE Type Main Gear Box | P20 | P20 |
| TA SOON 大順 | | 主變速與耕耘變速 | Main & Rotary Speed Changing | P20 | P20 |
| TA SOON 大順 | | 車軸鏈箱 | Chain Case | P17 | P17 |

WLK Agriculture Machine Used Products.

DATE : 2014/01/03

| BRAND | MODEL | 用處 | APPLICATION | Part No. | Oil Seals Size |
|------------|---------------|--------------|-------------------------------------|-----------------|-----------------|
| TA SOON 大順 | | 變速箱 | Speed Changing Case | P10 | P10 |
| TA SOON 大順 | | 變速箱 | Speed Changing Case | P15 | P15 |
| TA SOON 大順 | TS528/TS628單輪 | 單輪式(新型) | Wheel Shaft (New Type) | | 25*52*16 |
| TA SOON 大順 | TS528/TS628單輪 | 主變速與耕耘變速 | Main & Rotary Speed Changing | SC13225 | 13*22*5 |
| TA SOON 大順 | TS528/TS628單輪 | 主變速與耕耘變速 | Main & Rotary Speed Changing | 20.47.12 | 20*47*12/14 |
| TA SOON 大順 | TS528/TS628單輪 | 主變速與耕耘變速 | Main & Rotary Speed Changing | | 8*18.2*2 |
| TA SOON 大順 | TS528/TS628單輪 | 車軸鏈箱 | Chain Case | TA4-03040000 | 長方型 67 MM (RCA) |
| TA SOON 大順 | TS528/TS628單輪 | 車軸鏈箱 (舊型單輪) | Chain Case (Old Type Single wheel) | | 20*47*12/14 |
| TA SOON 大順 | TS528/TS628單輪 | 車軸鏈箱,輪軸 | Chain Case , Wheel Shaft | SC255212 | 25*52*12 |
| TA SOON 大順 | TS528/TS628單輪 | 高覆蓋 | Cover | SC15.35.4 | 15*35*4 |
| TA SOON 大順 | TS528/TS628單輪 | 輪軸 | Wheel Shaft | 20.47.12 | 20*47*12 |
| TA SOON 大順 | TS528/TS628單輪 | 輪軸 | Wheel Shaft | | 25*52*12 |
| TA SOON 大順 | TS528/TS628單輪 | 操作控制系統 | Operation control System | 601-10150000 | 加油索 4.2尺 |
| TA SOON 大順 | TS528/TS628單輪 | 操作控制系統 | Operation control System | 600-10160000 | 加油開關(小) |
| TA SOON 大順 | TS528/TS628單輪 | 操作控制系統 | Operation control System | TA-04140000 | 常閉式張力輪鋼索 |
| TA SOON 大順 | TS528/TS628單輪 | 操作控制系統 | Operation control System | 610-06200000 | 離合把手 |
| TA SOON 大順 | TS528/TS628單輪 | 變速箱 | Speed Changing Case | SC25355 | 25*35*5 |
| TA SOON 大順 | TS528/TS628單輪 | 變速箱 | Speed Changing Case | | 加油頭(小) |
| TA SOON 大順 | TS528/TS628單輪 | 變速箱,皮帶輪 | Speed Changing Case , Pulley | SC21317 | 21*31*7 |
| TA SOON 大順 | TS700雙輪 | KE 型主齒輪箱 | KE Type Main Gear Case | TC12.22.7 | 12*22*7 |
| TA SOON 大順 | TS700雙輪 | KE 型主齒輪箱 | KE Type Main Gear Case | SL22.42.8 | 22*42*8 |
| TA SOON 大順 | TS700雙輪 | KE 型主齒輪箱 | KE Type Main Gear Case | SL20.42.8 | 20*42*8 |
| TA SOON 大順 | TS700雙輪 | KE 型主齒輪箱 | KE Type Main Gear Case | TC28.43.8 | 28*43*8 |
| TA SOON 大順 | TS700雙輪 | KE 型主齒輪箱 | KE Type Main Gear Box | 600-01430000 | 10*18.5*2 |
| TA SOON 大順 | TS700雙輪 | KE 型主齒輪箱 | KE Type Main Gear Box | 610-02130000 | 12*22*2 |
| TA SOON 大順 | TS700雙輪 | KE 型主齒輪箱 | KE Type Main Gear Box | 600-01220000 | 43*10 |
| TA SOON 大順 | TS700雙輪 | KE 型主齒輪箱 | KE Type Main Gear Box | 630-10110000 | 上下(左右)鋼索 |
| TA SOON 大順 | TS700雙輪 | KE 型主齒輪箱 | KE Type Main Gear Box | 630-1014000 | 主變速鋼索 |
| TA SOON 大順 | TS700雙輪 | KE 型主齒輪箱 | KE Type Main Gear Box | 601-10150000 | 加油索A19-1 |
| TA SOON 大順 | TS700雙輪 | KE 型主齒輪箱 | KE Type Main Gear Box | 600-10160000 | 加油開關(小) |
| TA SOON 大順 | TS700雙輪 | KE 型主齒輪箱 | KE Type Main Gear Box | 600-10170000 | 轉向把手 |
| TA SOON 大順 | TS700雙輪 | KE 型主齒輪箱 | KE Type Main Gear Box | 630-10120000 | 轉向離合器鋼索 |
| TA SOON 大順 | TS700雙輪 | KE 型主齒輪箱,耕耘軸 | KE Type Main Gear Case ,Rotary | SL30.35.62.14.5 | 30*62*8/14.5 |

WLK Agriculture Machine Used Products.

DATE : 2014/01/03

| BRAND | MODEL | 用處 | APPLICATION | Part No. | Oil Seals Size |
|------------|---------------|--------------|--------------------------------------|-----------------|-----------------|
| TA SOON 大順 | TS700雙輪 | KE 型主齒輪箱,輪軸 | KE Type Main Gear Case , Wheel Shaft | SL35.40.62.15.5 | 35*62*13/15.5 |
| TA SOON 大順 | TS700雙輪 | 輪軸(改) | Wheel Shaft (Alternated) | | 35*65*8/14.5 |
| VALMET | 6000/8000 | 傳動PTO | TransmissionPTO | | 80*100*12 |
| WEN FON 文豐 | | | | | 17*32*6 |
| WEN FON 文豐 | | | | 09400-20358 | 20*35*8 |
| WEN FON 文豐 | | | | | 20*42*12 |
| WEN FON 文豐 | | | | 0481100070 | P007(6.8*1.9) |
| WEN FON 文豐 | | | | 19820-16121 | P20 |
| WEN FON 文豐 | SC126A履帶式搬運車 | | | | 30*35*3 |
| WEN FON 文豐 | SC126A履帶式搬運車 | | | | 25*43.5*10 |
| WEN FON 文豐 | SC126A履帶式搬運車 | | | | AS221(36*3.5) |
| WEN FON 文豐 | SC126A履帶式搬運車 | 滾輪 | Track Roller | G45 | G045(44.4*3.1) |
| WEN FON 文豐 | WR652雙輪 | | | 09400-13225 | 13*22*5 |
| WEN FON 文豐 | WR652雙輪 | | | | 14*24*8 |
| WEN FON 文豐 | WR652雙輪 | | | | 19*38*7 |
| WEN FON 文豐 | WR652雙輪 | 代用25X43.5X10 | Replacement25X43.5X10 | | 25*44*9 |
| WEN FON 文豐 | WR652雙輪 | 耕耘部鏈條箱及聯結箱 | Chain Case & Counter Case | 09400-20355 | 25*35*5 |
| WEN FON 文豐 | WR652雙輪 | 耕耘部鏈條箱及聯結箱 | Chain Case & Counter Case | 09500-22388 | 22*38*8 |
| WEN FON 文豐 | WR652雙輪 | 耕耘部鏈條箱及聯結箱 | Chain Case & Counter Case | 12652-18741 | 30*55*8/15 |
| WEN FON 文豐 | WR652雙輪 | 耕耘部鏈條箱及聯結箱 | Chain Case & Counter Case | 04718-01200 | 12*22*2 |
| WEN FON 文豐 | WR652雙輪 | 耕耘部鏈條箱及聯結箱 | Chain Case & Counter Case | 12652-16711 | 38*10 |
| WEN FON 文豐 | WR652雙輪 | 耕耘部鏈條箱及聯結箱 | Chain Case & Counter Case | 04718-00600 | 6*13.5*2 |
| WEN FON 文豐 | WR652雙輪 | 耕耘部鏈條箱及聯結箱 | Chain Case & Counter Case | 04811-01050 | 9.8*2.4(P010A) |
| WEN FON 文豐 | WR652雙輪 | 耕耘部鏈條箱及聯結箱 | Chain Case & Counter Case | 04811-00200 | P 20 * 2 |
| WEN FON 文豐 | WR652雙輪 | 輪軸 | Wheel Shaft | 12652-16831 | 35*62*13/19 |
| WEN FON 文豐 | WR652雙輪 | 齒輪箱系統 | Gear Case System | 09500-12227 | 12*22*7 |
| WEN FON 文豐 | WR652雙輪 | 齒輪箱系統 | Gear Case System | 12652-06731 | 35*62*13/15.5 |
| WEN FON 文豐 | WR652雙輪 | 齒輪箱系統 | Gear Box System | 04718-01000 | 10*18.5*2 |
| WEN FON 文豐 | WR652雙輪 | 齒輪箱系統 | Gear Box System | 12652-16711 | 38*10 |
| WEN FON 文豐 | WR652雙輪 | 齒輪箱系統 | Gear Box System | 04718-00800 | 8*18.2*2 |
| WEN FON 文豐 | WR652雙輪 | 齒輪箱系統 | Gear Box System | 04811-00200 | P 20 * 2.5 |
| WEN FON 文豐 | WR652雙輪 | 齒輪箱系統 | Gear Box System | 04911-00100 | P10*2.5 |
| WEN FON 文豐 | WR652雙輪 | 操作控制系統 | Operation control System | 12652-11021 | 主把手上下左右鋼索 |
| WEN FON 文豐 | WR652雙輪 | 操作控制系統 | Operation control System | 12652-11071 | 加油索 |
| WEN FON 文豐 | WR652雙輪 | 操作控制系統 | Operation control System | 12652-11061 | 加油開關(小) |
| WEN FON 文豐 | WR652雙輪 | 操作控制系統 | Operation control System | 12652-11091 | 張力輪鋼索 |
| WEN FON 文豐 | WR652雙輪 | 操作控制系統 | Operation control System | 12652-11041 | 轉向離合器手柄 |
| WEN FON 文豐 | WR652雙輪 | 操作控制系統 | Operation control System | 12652-11052 | 轉向離合鋼索 |
| WEN FON 文豐 | WR652雙輪 | 操作控制系統 | Operation control System | 12652-11082 | 變速鋼索 |
| WEN FON 文豐 | WR858/WR501單輪 | 正逆轉耕耘部系統 | F/R Rotary System | 09500-28288 | 28*38*7 |
| WEN FON 文豐 | WR858/WR501單輪 | 正逆轉耕耘部系統 | F/R Rotary System | 04718-01200 | 12*22*2 |
| WEN FON 文豐 | WR858/WR501單輪 | 正逆轉耕耘部系統 | F/R Rotary System | 04811-00200 | P 20 * 2.5 |

WLK Agriculture Machine Used Products.

DATE : 2014/01/03

| BRAND | MODEL | 用處 | APPLICATION | Part No. | Oil Seals Size |
|------------|---------------|--------------------|--------------------------------|--------------|----------------|
| WEN FON 文豐 | WR858/WR501單輪 | 正逆轉耕耘部系統 (中耕機用) | F/R Rotary System | 04811-01050 | 9.8*2.4(P010A) |
| WEN FON 文豐 | WR858/WR501單輪 | 正逆轉耕耘部系統/ 齒輪箱 | F/R Rotary System /Gear Box | 04718-01000 | 10*18.5*2 |
| WEN FON 文豐 | WR858/WR501單輪 | 耕耘部系統 | Rotary System | 04718-01000 | 12*22*2 |
| WEN FON 文豐 | WR858/WR501單輪 | 耕耘部系統 | Rotary System | 04718-00600 | 6*13.5*2 |
| WEN FON 文豐 | WR858/WR501單輪 | 耕耘部系統 | Rotary System | 04811-01050 | 9.8*2.4(P010A) |
| WEN FON 文豐 | WR858/WR501單輪 | 耕耘部系統 | Rotary System | 04811-00200 | P 20 * 2.5 MM |
| WEN FON 文豐 | WR858/WR501單輪 | 耕耘部系統(皮帶 軸) | Rotary System (Pulley) | 09500-28388 | 28*38*7 |
| WEN FON 文豐 | WR858/WR501單輪 | 耕耘部系統(耕耘 軸) | Rotary System (Rotary) | 09502-54715 | 25*47*12/14.8 |
| WEN FON 文豐 | WR858/WR501單輪 | 輪軸 | Wheel Shaft | 09502-54715 | 25*47*12/14.8 |
| WEN FON 文豐 | WR858/WR501單輪 | 齒輪箱 | Gear Box | 12652-16711 | 38*10 |
| WEN FON 文豐 | WR858/WR501單輪 | 齒輪箱 | Gear Box | 04811-00100 | 9.8*1.9(P010) |
| WEN FON 文豐 | WR858/WR501單輪 | 操控系統 | Operation control System | 12501-11021 | 主把手上下左右鋼索 |
| WEN FON 文豐 | WR858/WR501單輪 | 操控系統 | Operation control System | 12652-11071 | 加油索 4.2 尺 |
| WEN FON 文豐 | WR858/WR501單輪 | 操控系統 | Operation control System | 12652-11061 | 加油開關(小) |
| WEN FON 文豐 | WR858/WR501單輪 | 操控系統 | Operation control System | 12501-11131 | 張力輪手柄 |
| WEN FON 文豐 | WR858/WR501單輪 | 操控系統 | Operation control System | 12501-11141 | 張力輪鋼索 |
| YANMER | | | | AE1306K | 25*38*7 |
| YANMER | | | | AE1666F | 30*42*8 |
| YANMER | | | | | 45*72*10 |
| YANMER | | | | | 17*30/40*9 |
| YANMER | | | | 4564-7314-6 | 45*64/73*14.5 |
| YANMER | | | | | 50*68*14.3 |
| YANMER | | | | | 50*68*12.5 |
| YANMER | | | | | 35*45*17 |
| YANMER | | | | 24321-000300 | G30 |
| YANMER | | | | 24321-000350 | G35 |
| YANMER | | | | 24321-000500 | G50 |
| YANMER | | | | 24321-000750 | G75 |
| YANMER | | | | 24321-000950 | G95 |
| YANMER | | | | 24311-240100 | P10A |
| YANMER | | | | 24311-000150 | P15 |
| YANMER | | | | 24312-000150 | P15 |
| YANMER | | | | 24311-000160 | P16 |
| YANMER | | | | 24314-000180 | P18 |
| YANMER | | | | 24311-000220 | P22 |
| YANMER | | | | 24311-000240 | P24 |
| YANMER | | | | 24311-000360 | P36 |
| YANMER | | | | 24311-000070 | P7 |
| YANMER | | | | 24311-000080 | P8 |
| YANMER | | | | 24311-000090 | P9 |
| YANMER | | | | 24341-000112 | S11.2 |
| YANMER | | | | 24341-000150 | S15 |
| YANMER | | | | 24341-000180 | S18 |
| YANMER | | | | 24341-000260 | S26 |
| YANMER | | | | 24341-000480 | S48 |
| YANMER | | | | 24341-000500 | S50 |
| YANMER | | | | 24341-000670 | S67 |
| YANMER | | | | 24341-000900 | S90 |
| YANMER | | | | | 伸縮防泥像皮(七唇) |
| YANMER | | | | | 推板,跑道(白塑膠型) |
| YANMER | | | | | 緩衝像皮 |

WLK Agriculture Machine Used Products.

DATE : 2014/01/03

| BRAND | MODEL | 用處 | APPLICATION | Part No. | Oil Seals Size |
|--------|-----------|---------------|------------------------------|--------------|------------------------|
| YANMER | | | | | 轉輪(白塑膠型) |
| YANMER | | F.D. 噴射 | F.D. Inject | 119000-51410 | S18 |
| YANMER | | F.D. 噴射 | F.D. Inject | 129155-51280 | S6 |
| YANMER | | 七齒軸 | 7T Axle | 24321-000400 | G40 |
| YANMER | | 引擎 | Engine | 24311-000320 | P32 |
| YANMER | | 引擎 | Engine | 24341-001350 | S135 |
| YANMER | | 引擎 | Engine | 24341-000240 | S24 |
| YANMER | | 主變速 | Changing | 24321-000700 | G70 |
| YANMER | | 主變速 | Changing | 24311-000140 | P14 |
| YANMER | | 油壓 (1) | Hydraulic (1) | 24311-000200 | P20 |
| YANMER | | 油壓 (1) | Hydraulic (1) | 24341-000800 | S80 |
| YANMER | | 油壓 (2) | Hydraulic (2) | 24321-000250 | G25 |
| YANMER | | 油壓 (2) | Hydraulic (2) | 24311-000100 | P10 |
| YANMER | | 油壓 (2) | Hydraulic (2) | 24341-000290 | S29 |
| YANMER | | 前輪 | Front Wheel | AE7451G | 57*80*12 |
| YANMER | | 活動滾輪 | Roller | 24311-000250 | P25 |
| YANMER | | 活動滾輪4個 | Roller | 1E8080-73430 | 50*72*18 |
| YANMER | | 耕耘軸大 | Rotary Big | | 55*85*13/19 |
| YANMER | | 配管 | Pipe | 24311-000180 | P18 |
| YANMER | | 副變速 | Auxiliary Speed Changing | 24311-000125 | P12.5 |
| YANMER | | 補助輪 | Carry Roller | 1E6460-73160 | 25*30*14 |
| YANMER | | 縱搬送 | Horizontal Transit | 24321-000600 | G60 |
| YANMER | 1300 | | | | 加油線 Cable 8尺 8 |
| YANMER | 1400 | | | | 加油線 Cable 11尺 2 |
| YANMER | 1800 | 車軸 | Axle | AQ7444E | 40*80*18.5/20.5 |
| YANMER | 1800 | 脫穀管 | Threshing Pipe | | Threshing Pipe 0.5/0.7 |
| YANMER | 1800 | 滾輪 | Track Roller | | 25*47*12/14.8 |
| YANMER | 1800 2200 | | | | 加油線 Cable 9尺 5 |
| YANMER | 1800 2200 | | | 1E6030-41230 | 17*35*7 |
| YANMER | 1800 2200 | | | 19419-28290 | 30*42*8 |
| YANMER | 1800 2200 | | | 1E7030-53160 | 30*45*8 |
| YANMER | 1800 2200 | | | 1E6030-34220 | 25*45*10 |
| YANMER | 1800 2200 | | | 1A1040-28820 | 30*52*8 |
| YANMER | 1800 2200 | 曲軸(搖輪) | Crank Shaft | | 70*88*12 |
| YANMER | 1800 2200 | 尾輪 | Idler | | 20*47*10 |
| YANMER | 1800 2200 | 車軸(牛腳) | Transmission Shaft | 1E6030-53290 | 40*80*18.5/20.5 |
| YANMER | 1800 2200 | 脫穀筒 | Threshing Drum | 1E6030-53130 | 25*40*8 |
| YANMER | 1800 2200 | 脫穀筒 | Threshing Drum | 1E6140-41420 | 20*40*7 |
| YANMER | 1800 2200 | 滾輪軸 | Track Roller Shaft | 1E6210-73230 | 25*47/54*13 |
| YANMER | 1800 2200 | 輸送軸 | Transit Shaft | 1E6150-41330 | 20*35*7 |
| YANMER | 1800 2200 | 輸送軸 | Transit Shaft | | 15*20*11 |
| YANMER | 1800/2710 | 滾輪 | Track Roller | | 25*52*12 |
| YANMER | 24 HP | 耕耘軸小 | Rotary Small | | 40*72*10/16 |
| YANMER | 24HP | 後輪*AQ2967E通用* | Rear Wheel*AQ2967E | AE7450F | 57*75*12 |
| YANMER | 24HP/265 | 耕耘軸小 | Rotary Small | | 35*60*12/18 |
| YANMER | 265.24 | 前輪橫軸 | Front Wheel Horizontal Shaft | | 62*80*12 |
| YANMER | 2710 | 吸取驅動 | Suction Transmission | | 20*40*7 |
| YANMER | 2710 | 吸取驅動 煞車器 | Suction Transmission Brake | 24421-203507 | 20*35*7 |
| YANMER | 2710 | 尾輪 | Idler | 1E6210-73230 | 25*47/54*13 |
| YANMER | 2710 | 尾輪 | Idler | | 20*47*10 |
| YANMER | 2710 | 脫穀桶 驅動 | Threshing Drum Transmission | 1E6021-36270 | 25*47*8 |
| YANMER | 2710 | 脫穀輸入齒輪 | Threshing Input Gear | | 30*42*8 |
| YANMER | 2710 | 脫穀輸入齒輪 | Threshing Input Gear | | 20*30*12.6 |
| YANMER | 2710 | 割取離合器 | Clutch | 24421-173507 | 17*35*7 |

WLK Agriculture Machine Used Products.

DATE : 2014/01/03

| BRAND | MODEL | 用處 | APPLICATION | Part No. | Oil Seals Size |
|--------|-------------|-------------------------|-------------------------------------|--------------|-----------------|
| YANMER | 2710 | 報投驅動 | Transmission | 1E6030-53130 | 25*40*8 |
| YANMER | 2710 | 滾輪 | Track Roller | 24421-254708 | 25*47*10 |
| YANMER | 2710 | 輸送軸 | Transit Shaft | 1E6050-19190 | 15*25*7 |
| YANMER | 2710 | 輸送軸 | Transit Shaft | 1E6030-41280 | 17*30*8 |
| YANMER | 2710 465 | 穀粒輸送 | Grain Transit | | 20*35*5/7 |
| YANMER | 2710 465 | 穀粒輸送 | Grain Transit Shaft | | 15*20*11 |
| YANMER | 2710/1800 | 尾輪 | Idler | | 25*47*12/14.8 |
| YANMER | 2710/1800 | 尾輪 | Idler | | 28*47*8 |
| YANMER | 2710/1800 | 尾輪 | Idler | | 30*52*10 |
| YANMER | 2710/1800 | 尾輪 | IDLER | | 20*28*11 |
| YANMER | 2710/1800 | 尾輪 | IDLER | | 25*30*14 |
| YANMER | 2710/1800 | 滾輪 | Track Roller | | 25*52*12 |
| YANMER | 2710/3310 | 車軸(七齒) | Axle(7T) | 1E6030-53290 | 40*80*18.5/20.5 |
| YANMER | 3000 | 曲軸後 | Crank Shaft Rear | | 75*100*13 |
| YANMER | 3000 | 後輪*BE1687E同一組*,套:60*75* | Rear Whee | AG3613A | 75*100*7 |
| YANMER | 3000 4300 | 前輪上面站軸 | Front Wheel Vertical Shaft Upper | | 60*80*13/28 |
| YANMER | 3000 4300 | 前輪上面鐵蓋(防草蓋) | Front Wheel Upper Cover | 8409 | 68*79*11.5 |
| YANMER | 3000DP | 前輪站軸 | Front Wheel Vertical Shaft | 194321-13930 | 60*75*6 |
| YANMER | 3000DP | 前輪站軸 | Front Wheel Vertical Shaft | 194321-13920 | 60*75*9 |
| YANMER | 3000DP | 前輪站軸 新型 | Front Wheel Vertical Shaft New Type | | 60*75*13/26 |
| YANMER | 3000DP | 後傳動部 | Rear Transmission | 22311-355505 | 35*55*5 |
| YANMER | 3000DP | 後傳動部 | Rear Transmission | 22311-355511 | 35*55*11 |
| YANMER | 3000DP | 傳動 PTO | Transmission PTO | 194130-26350 | 42*60*9 |
| YANMER | 3000DP | 傳動 PTO | Transmission PTO | 194130-33452 | 35*42*13 |
| YANMER | 3000DP | 煞車 | Brake | 194145-32660 | 55*78*12 |
| YANMER | 3000DP 4300 | 前擔輪橫4WD | Front Wheel Horizontal 4WD | 194321-13960 | 53*88*8.5 |
| YANMER | 3000DP 4300 | 前擔輪橫4WD | Front Wheel Horizontal Shaft 4WD | | 45*53*23 |
| YANMER | 3000DP 4300 | 後輪軸 | Rear Wheel Shaft | 194145-32740 | 75*100*7 |
| YANMER | 3000DP 4300 | 後輪軸 | Rear Wheel Shaft | 194145-32730 | 75*100*13 |
| YANMER | 3000DP 4300 | 耕耘軸大4WD | Rotary Big4WD | 22311-608010 | 60*80*10 |
| YANMER | 3000DP 4300 | 耕耘軸大4WD | Rotary Big 4WD | | 45*60*30 |
| YANMER | 3000DP 4300 | 耕耘軸小4WD | Rotary Small4WD | 22321-557010 | 55*70*10 |
| YANMER | 3000DP 4300 | 耕耘軸小4WD | Rotary Small 4WD | | 45*55*27 |
| YANMER | 3310 | 滾輪 | Track Roller | | 25*47*8 |
| YANMER | 3500 | 尾輪 | Idler | | 25*62*12/22 |
| YANMER | 3500 | 滾輪 | Track Roller | BQ4096E | 25*52*11/18 |
| YANMER | 4,6 行 | | | | 分離針(鐵板型) |
| YANMER | 4300 | 前輪 | Front Wheel | BQ3163E | 60*80*13/28 |
| YANMER | 45/465 | 活動座 | Equalizer Shaft | | 45*72*12 |
| YANMER | 45/465 | 活動座 | Equalizer | | 35*45*17 |
| YANMER | 45/465 | 滾輪活動座 | Equalizer | 1E8255-73060 | 40*62*12 |
| YANMER | 45/465 | 滾輪活動座 | Track Roller (Equalizer) | | 30*40*18 |
| YANMER | 450 | 前後滾輪(原裝) | Track Roller (Original) | 1E8255-73060 | 40*62*12 |
| YANMER | 450/465 | 固定座 | Roller | | 40*62*12 |
| YANMER | 450/465 | 固定座 | Roller | | 30*40*18 |
| YANMER | 450/465 | 活動座 | Equalizer | | 30*62*11/17 |
| YANMER | 450/465 | 活動座(原裝) | Equalizer (Original) | 1E8255-73060 | 40*62*12 |

WLK Agriculture Machine Used Products.

DATE : 2014/01/03

| BRAND | MODEL | 用處 | APPLICATION | Part No. | Oil Seals Size |
|--------|-----------------|----------|-------------------------------------|--------------|------------------|
| YANMER | 450/465 | 活動座(原裝) | Equalizer (Original) | 1E8255-73070 | 30*40*18 |
| YANMER | 450/465 | 活動座蓋 | Equalizer Cover | 1E8080-54460 | 62/72*10 |
| YANMER | 450/465 | 滾輪 (原裝) | Track Roller (Original) | 1E6820-73230 | 25*52*10 |
| YANMER | 450/465/415/525 | 補助輪(改裝) | Carry Roller (Revised) | | 20*47*12/14 |
| YANMER | 450/465/475 | 尾輪 | Idler | | 25*52*10 |
| YANMER | 450/465/475 | 尾輪(原裝) | Idler (Original) | 1E6690-73890 | 20*47*10 |
| YANMER | 450/465/475/525 | (補助輪) | (Carry Roller) | | 20*42*8/14.5 |
| YANMER | 450/465/475/525 | 尾輪 | Idler | | 20*47*10 |
| YANMER | 450/465/475/525 | 尾輪 | Idler | | 25*52*12 |
| YANMER | 450/465/475/525 | 尾輪 | Idler | | 25*52*16 |
| YANMER | 450/465/475/525 | 尾輪(原裝) | Idler (Original) | | 20*47*10/12 |
| YANMER | 450/465/475/525 | 前後滾輪(原裝) | Track Roller (Original) | | 30*62*11/17 |
| YANMER | 450/465/475/525 | 活動輪 | Equalizer | | 25*52*10 |
| YANMER | 450/465/475/525 | 補助輪 | Carry Roller | 1E6570-73880 | 25*42*8 |
| YANMER | 450/465/475/525 | 滾輪 | Track Roller | | 25*52*16 |
| YANMER | 450/465/525/475 | 滾輪 | Track Roller | | 25*52*12 |
| YANMER | 450/465/525/475 | 滾輪 | Track Roller | | 30*62*11/17 |
| YANMER | 465 | 前後滾輪(原裝) | F/R Track Roller (Original) | 1E8255-73070 | 30*40*18 |
| YANMER | 465 | 補助輪(原裝) | Carry Roller (Original) | | 20*42*8/14.5 |
| YANMER | 465/450 | 固定座(原裝) | Equalizer Track Roller (Original) | | 30*62*11/17 |
| YANMER | 465/450 | 固定座滾輪 | Roller | | 25*52*16 |
| YANMER | 475 | 耕耘軸大 | Rotary Big | | 75*105*12.5*18.5 |
| YANMER | 475/465 | 補助輪 | Carry Roller | 1E6750-73880 | 25*42*8 |
| YANMER | 475/525 | 固定座(原裝) | Equalizer Shaft (Original) | | 35*72*14/19.5 |
| YANMER | 475/525 | 固定座滾輪 | Roller | | 25*52*16 |
| YANMER | 475/525 | 活動座(原裝) | Equalizer Shaft (Original) | | 35*72*14/19.5 |
| YANMER | 475-465 | 補助輪(代用) | Carry Roller (Replacement) | 1E6570-73880 | 30*42*8 |
| YANMER | 475-465 | 補助輪(代用) | Carry Roller (Replacement) | 1E6570-73880 | 25*30*14 |
| YANMER | 5000 | | | | 80*105*15 |
| YANMER | 5000 | 引擎曲軸 | Engine Crank Shaft | | 90*115*13 |
| YANMER | 5000 | 前輪 | Front Wheel | BQ1393E | 75*105*13 |
| YANMER | 5000 | 後輪 | Rear Wheel | AE3746G | 65*105*15/25.7 |
| YANMER | 5000 | 耕耘軸大 | Rotary Big | | 72*100*13/17 |
| YANMER | 5000 | 耕耘軸大.小 | Rotary Big. Small | | 60*90*12/18 |
| YANMER | 5000 4300 | 傳動 PTO | Transmission PTO | AQ2110E | 35*60*12/18 |
| YANMER | 525 | 脫谷輪 | Threshing Drum Wheel | | 30*42*8 |
| YANMER | 525/450/475 | 前後滾輪(原裝) | Track Roller (Original) | | 30*62*11/17 |
| YANMER | 525/475 | 固定座 | Equalizer Shaft | | 35*72*20 |
| YANMER | 525/475 | 活動座 | Equalizer Shaft | | 35*72*14/19.5 |
| YANMER | 6 行 | | | | 導板(新型) |
| YANMER | 7 行 | | | | 分離針左,右一組 |
| YANMER | 7 行 | | | | 推苗桿(有螺絲牙)舊型 |
| YANMER | 750 1300 | 尾輪 | Idler | | 20*47*12 |
| YANMER | 750 1300 | 車軸(牛腳) | Transmission Shaft | | 35*72*14/19.5 |
| YANMER | 750 1300 | 脫穀桶 | Threshing Drum | 1E6021-36170 | 25*47*8 |
| YANMER | 750 1300 | 滾輪 | Track Roller | 1E6031-73370 | 28*47*8 |
| YANMER | 750 1300 | 滾輪 | Track Roller | 1E6031-73363 | 20*28*11 |

WLK Agriculture Machine Used Products.

DATE : 2014/01/03

| BRAND | MODEL | 用處 | APPLICATION | Part No. | Oil Seals Size |
|--------|------------------------|----------------|--|--------------|-----------------|
| YANMER | 750 1300 | 滾輪 | Track Roller | | 20*28*14 |
| YANMER | 750 1300 | 輸送軸 | Transit Shaft | | 15*25*4 |
| YANMER | 750 1300 | 輸送軸 | Transit Shaft | 1E6030-41280 | 17*30*8 |
| YANMER | AP60 | | | | 15*25*7 |
| YANMER | AP60 | | | | 12*25*7 |
| YANMER | AP60 | | | | 扶站正導板(壓嘴板) |
| YANMER | AP60 | 10-18 | 10-18 | 6080-14770 | 25*52*7 |
| YANMER | AP60 | 11-11 | 11-11 | 123644-34530 | 13*28*6 |
| YANMER | AP60 | 19-9 角牙 | 19-9 Cross Feed | 6220-35130 | 14*28*10 |
| YANMER | AP60 | 21-8 | 21-8 | 6220-32150 | 20*47*7 |
| YANMER | AP60 | 25-14圖 | 25-14 Drawing | 6053-32360 | 28/34*6 |
| YANMER | AP60 | 2-8 | 2-8 | 122650-42310 | 20*35*7 |
| YANMER | AP60 | 29-4 播手 | 29-4 Planting Arm | 6054-95600 | 8*18*7 |
| YANMER | AP60 | 29-6 圖 | 29-6 Drawing | 6054-95610 | 8*18*5.7 |
| YANMER | AP60 | 62-6圖 播手防泥 | 62-6 Drawing Planting Arm Scraper | | 8*18/26*16.5 |
| YANMER | AP60 | 9-32 | 9-32 | 6081-13470 | 30*47*8 |
| YANMER | AP60 | 9-44 播手 | 9-44 Planting Arm | 1C6220-13350 | 25*40*12 |
| YANMER | AP60 | 播手,25-9 圖 | Planting Arm ,25-9 Drawing | 6054-32350 | 16*28*5.5/6.5 |
| YANMER | AP60 | 播手防泥(內) | Planting Arm Scraper (Inner) | | 8*18*9 |
| YANMER | AP600 | AXLE CASE | AXLE CASE | | 25*40*12 |
| YANMER | AP600 | AXLE CASE | AXLE CASE | | 20*47*7 |
| YANMER | AP600 | & | CHANGE SHAFT & | 24421-203208 | 20*32*8 |
| YANMER | AP600 | MAIN SHAFT | MAIN SHAFT | 24421-153007 | 15*30*7 |
| YANMER | AP600 | PLANTING CIUTC | PLANTING CIUTC | 24421-173007 | 17*30*7 |
| YANMER | AP600 | 播手 | Planting Arm | AE0526A | 14*28*7 |
| YANMER | AP600/ AP400 | 播手曲軸 | Planting Arm Crank Shaft | | 16*30*10 |
| YANMER | AP600/SI800 | 後輪 | Rear Wheel | AE2074E | 35*52/64*11/12 |
| YANMER | CA32 | | | | 20*28*11 |
| YANMER | CA32 | 尾輪 | Idler | | 28*47*8 |
| YANMER | CA32 | 後輪 | Idler | | 30*52*10 |
| YANMER | CA32 | 後輪 | Idler | | 25*30*14 |
| YANMER | CA32 | 脫穀齒輪 B相 | Threshing Drum Gear B | | 30*42*8 |
| YANMER | CA32 | 滾輪 | Track Roller | | 25*52*12 |
| YANMER | CA45/CA465/CA475/CA525 | 七齒車軸,(| 7T Axle,(| AQ3020P | 54*80*10 |
| YANMER | CA450/465 | 車軸(七齒) | Axle(7T) | 1E6740-55490 | 54*80*13.5/15.8 |
| YANMER | CA465 | 補助輪 | Carry Roller | | 20*47*12/14 |
| YANMER | CA465 EX | 六齒軸心 | Transmission Shaft 6T | 1E6740-55490 | 54*80*13.5/15.8 |
| YANMER | CA465EXN | 車軸(七齒) | Axle(7T) | 1E6740-55490 | 54*80*13.5/15.8 |
| YANMER | CA465EXN/525 | 滾輪(活動座) | Track Roller (Equalizer) | | 30*62*12/18 |
| YANMER | CA475G/CA450 | 活動座? | Equalizer | | 62*72*10 |
| YANMER | CA525 | | | | 20*35*8 |
| YANMER | CA525 | | | | 30*40*18 |
| YANMER | CA525 | 各機型 前後滾輪 通用 | F/R Track Roller all models used | 1E8255-73070 | 30*40*18 |
| YANMER | CA525 | 尾輪 | Idler | | 25*52*16 |
| YANMER | CA525 | 尾輪(原裝) | Idler (Original) | 1E8255-73060 | 40*62*12 |
| YANMER | CA525 | 尾輪(改裝) | Idler (Alternated) | | 25*52*16 |
| YANMER | CA525 | 尾輪(原裝) | Idler (Original) | | 40*62*12 |
| YANMER | CA525 | 活動座(原裝) | Track Roller Equalizer (Original) | | 30*62*11/17 |

WLK Agriculture Machine Used Products.

DATE : 2014/01/03

| BRAND | MODEL | 用處 | APPLICATION | Part No. | Oil Seals Size |
|--------|-------------|--------------------|--|--------------|-----------------|
| YANMER | CA525 | 脫穀齒輪箱 | Threshing Drum Gear Case | 24411-203508 | 20*35*8 |
| YANMER | CA525 | 脫穀齒輪箱 | Threshing Drum Gear Case | 24411-204007 | 20*40*7 |
| YANMER | CA525 | 脫穀齒輪箱 | Threshing Drum Gear Case | 24411-304208 | 30*42*8 |
| YANMER | CA525 | 脫穀齒輪箱 | Threshing Drum Gear Case | 1E8230-35100 | 32*52*7 |
| YANMER | CA525 | 補助輪 | Carry Roller | | 20*47*12 |
| YANMER | CA525 | 滾輪 | Track Roller | | 25*52*16 |
| YANMER | CA525D | 前割取部 | Front Reaping Shaft | 1E6720-91960 | 40*7 |
| YANMER | CA525DC | | | 24421-152507 | 15*25*7 |
| YANMER | CA525DC | | | 24421-254708 | 25*47*8 |
| YANMER | CA525DC | CONVEY ROLLER R | CONVEY ROLLER R | 21-152507UPP | 15*25*7 |
| YANMER | CA525DC | CARRIER ROLLER補助輪 | CARRIER ROLLERCarry Roller | 1E6570-73880 | 25*42*8 |
| YANMER | CA525DC | COUNTER SHAFT | COUNTER SHAFT | 24421-203507 | 20*35*7 |
| YANMER | CA525DC | DRUM DRIVE SHAFT | DRUM DRIVE SHAFT | 304508 | 30*45*8 |
| YANMER | CA525DC | DRUM DRIVE SHAFT | DRUM DRIVE SHAFT | 385508 | 38*55*8 |
| YANMER | CA525DC | FEED CHAIN SHAFT | FEED CHAIN SHAFT | 24411-203508 | 20*35*8 |
| YANMER | CA525DC | FEED CHAIN SHAFT | FEED CHAIN SHAFT | 24411-304208 | 30*42*8 |
| YANMER | CA525DC | IDLER 尾輪 | IDLER Idler | 1E6690-73890 | 20*47*10/12 |
| YANMER | CA525DC | IDLER 尾輪 | IDLER Idler | 1E8255-73060 | 40*62*12 |
| YANMER | CA525DC | IDLER 尾輪 | IDLER | 1E8255-73070 | 30*40*18 |
| YANMER | CA525DC | SHAFT | ING INPUT SHAFT | 230-35100 | 32*52*7 |
| YANMER | CA525DC | NG EDGE DRIVE | NG EDGE DRIVE | 740-37620 | 25*47*6 |
| YANMER | CA525DC | OIL SUMP | OIL SUMP | 124411-01780 | 95*115*10 |
| YANMER | CA525DC | P.T.O. SHAFT | P.T.O. SHAFT | 24421-253807 | 25*38*7 |
| YANMER | CA525DC | ROLLER | ROLLER | 1E8255-73060 | 40*62*12 |
| YANMER | CA525DC | ROLLER | ROLLER | 1E8255-73070 | 30*40*18 |
| YANMER | CA525DC | SPROCKET SHAFT車軸七齒 | SPROCKET SHAFT Axle 7T | 1E6740-55490 | 54*80*13.5/15.8 |
| YANMER | CA525DC | 尾輪 | Idler | 1E8255-73060 | 40*62*12 |
| YANMER | CA525DC | 和滾輪通用 | Track Roller | | 30*40*18 |
| YANMER | CA525DC | 活動座 | Equalizer | 1E6680-73040 | 35*45*17 |
| YANMER | CA525DC | 活動座? | Equalizer | 1E8080-54460 | 62/72*10 |
| YANMER | CA525DC | 活動座滾輪 | Roller | 1E6820-73230 | 25*52*10 |
| YANMER | CA525DC | 割刀管 | Reaping Pipe | | 40*7 |
| YANMER | CA525DC | 補助輪 | Carry Roller | | 28*47*8 |
| YANMER | CA525DC | 補助輪代用 | Carry Roller Replacement | | 20*30*12.6 |
| YANMER | CA525DC | 補助輪代用(原裝型) | Carry Roller Replacement(Original Type) | | 30*42*8 |
| YANMER | CA525DC | 導輪 | Carry Roller | | 20*28*14 |
| YANMER | CA525新型 | 補助輪 | Carry Roller | | 25*42*8 |
| YANMER | F 475 | 前輪站軸上面 | Front Wheel Vertical Shaft Upper | | 68*90*12 |
| YANMER | F 475 46 HP | 前輪 | Front Wheel | | 60*95*12/19 |
| YANMER | F 475(4WD) | 前輪站軸上面 | Front Wheel Vertical Shaft Upper | AE3746G | 80*105*15 |
| YANMER | F 475(4WD) | 前輪站軸上面 | Front Wheel Vertical Shaft Upper | | 65*80*26 |
| YANMER | F 475(4WD) | 前輪橫軸 | Front Wheel Horizontal Shaft | | 55*82*10.5/17 |

WLK Agriculture Machine Used Products.

DATE : 2014/01/03

| BRAND | MODEL | 用處 | APPLICATION | Part No. | Oil Seals Size |
|--------|--------------------|-----------------|---------------------------------------|---------------|------------------|
| YANMER | GC85 | | | AE1322F | 25*42*8 |
| YANMER | GC85 | | | AE1692E | 30*47*8 |
| YANMER | GC85EX(EXC)1998/07 | | | 24421-253807 | 25*38*7 |
| YANMER | GC85EX(EXC)1998/07 | | | 24421-204007 | 20*40*7 |
| YANMER | GC85EX(EXC)1998/07 | | | 24421-304208 | 30*42*8 |
| YANMER | GC85EX(EXC)1998/07 | | | 24421-355008 | 35*50*8 |
| YANMER | GC85EX(EXC)1998/07 | | | 24421-355511 | 35*55*11 |
| YANMER | GC85EX(EXC)1998/07 | | | 1E8540-01200 | 防震擊 (引擎) |
| YANMER | GC85EX(EXC)1998/07 | HST高壓幫浦 | HST Hydraulic Pump | | 30*50*11 |
| YANMER | GC85EX(EXC)1998/07 | T/M驅動 | T/MTransmission | 194190-32370 | 45*72*12 |
| YANMER | GC85EX(EXC)1998/07 | 七齒軸 | 7T Shaft | 1E6740-55490 | 54*80*13.5/15.8 |
| YANMER | GC85EX(EXC)1998/07 | 入力 | Intake | 24421-305208 | 30*52*8 |
| YANMER | GC85EX(EXC)1998/07 | 入力 | Intake | 24421-406212 | 40*62*12 |
| YANMER | GC85EX(EXC)1998/07 | 入力 | Intake | 1E62310-53480 | 30*40*18 |
| YANMER | GC85EX(EXC)1998/07 | 上搬送 R後 | Upper Convey Rear | 24421-152507 | 15*25*7 |
| YANMER | GC85EX(EXC)1998/07 | 引擎 橫 驅動 | Engine Horizontal Transmission 2 | 1E8080-54460 | 62/72*10 |
| YANMER | GC85EX(EXC)1998/07 | 引擎 縱 驅動2 | Engine Vertical Transmission 2 | 1E6452-13950 | 12*18*5 |
| YANMER | GC85EX(EXC)1998/07 | 引擎 縱 驅動2 | Engine Vertical Transmission 2 | 24430-203506 | 20*35*6 |
| YANMER | GC85EX(EXC)1998/07 | 引擎(左內)(右內46-23) | Engine(Left Inner)(Right Inner 46-23) | 24421-152507 | 15*25*7 |
| YANMER | GC85EX(EXC)1998/07 | 方向機 (2) | Steering (2) | 24421-173508 | 17*35*8 |
| YANMER | GC85EX(EXC)1998/07 | 曲軸 | Crank Shaft | 124411-01780 | 95*115*10 |
| YANMER | GC85EX(EXC)1998/07 | 尾輪 | IDLER | 1E8420-55460 | 30*40*18 |
| YANMER | GC85EX(EXC)1998/07 | 撥室 | | 27260-320001 | 32 |
| YANMER | GC85EX(EXC)1998/07 | 撥胴驅動 | Thrushing DrumTransmission Shaft | 194190-22370 | 45*72*12 |
| YANMER | GC85EX(EXC)1998/07 | 撥胴驅動軸 | Thrushing DrumTransmission Shaft | 24421-304508 | 30*45*8 |
| YANMER | GC85EX(EXC)1998/07 | 撥胴驅動軸 | Thrushing DrumTransmission Shaft | 24423-385508 | 38*55*8 |
| YANMER | GC85EX(EXC)1998/07 | 前後滾輪 | F/R Track Roller | 1E8050-73260 | 60*86*20 |
| YANMER | GC85EX(EXC)1998/07 | 活動滾輪 | Equalizer Track Roller | 172637-37400 | ES764-466620浮動油封 |
| YANMER | GC85EX(EXC)1998/07 | 活動滾輪 | Roller | 24311-000250 | P25 |
| YANMER | GC85EX(EXC)1998/07 | 耕 搬送 (1) | | 24421-152507 | 15*25*7 |
| YANMER | GC85EX(EXC)1998/07 | 割刀軸動 | Reaping Shaft | | 25*35*5 |
| YANMER | GC85EX(EXC)1998/07 | 割刀軸動 | Reaping Shaft | | 47/54*9.5 |
| YANMER | GC85EX(EXC)1998/07 | 割刀驅動 | Reaping Shaft | 24430-254005 | 25*40*6 |
| YANMER | GC85EX(EXC)1998/07 | 割刀驅動 | Reaping Shaft | 1E6740-37620 | 25*47*6 |
| YANMER | GC85EX(EXC)1998/07 | 割刀驅動 R | Reaping Shaft | 24430-254005 | 25*40*6 |
| YANMER | GC85EX(EXC)1998/07 | 割刀驅動 R | Reaping Shaft | 1E6740-37620 | 25*47*6 |
| YANMER | GC85EX(EXC)1998/07 | 割刀驅動 R | Reaping Shaft R | 27260-470001 | 47/54*9.5 |
| YANMER | GC85EX(EXC)1998/07 | 割取軸C | Reaping Shaft | 24421-254208 | 25*42*8 |
| YANMER | GC85EX(EXC)1998/07 | 割取驅動軸 | Reaping Shaft | 24421-386209 | 38*62*9 |
| YANMER | GC85EX(EXC)1998/07 | 割取驅動軸 | Reaping Shaft | 194990-59630 | 25*38*18 |
| YANMER | GC85EX(EXC)1998/07 | 補助輪 (下) | Carry Roller (Lower) | 1E8080-73430 | 50*72*18 |
| YANMER | GC85EX(EXC)1998/07 | 補助輪 (上) | Carry Roller (Upper) | 1E6460-73160 | 25*30*14 |
| YANMER | GC85EX(EXC)1998/07 | 駐車 | | 24421-203208 | 20*32*8 |
| YANMER | GC85EX(EXC)1998/07 | 選別驅動 | Alternative Transmission | 24421-304708 | 30*47*8 |
| YANMER | K22 | 車心 耕耘軸 | Transmission Shaft / Rotary | | 48*70*12 |

WLK Agriculture Machine Used Products.

DATE : 2014/01/03

| BRAND | MODEL | 用處 | APPLICATION | Part No. | Oil Seals Size |
|--------|---------|--------------|--|--------------|----------------|
| YANMER | K22 | 車心 耕耘軸 | Transmission Shaft / Rotary | | 40*48 *29.5 |
| YANMER | K22 | 車心 耕耘軸, 大小一樣 | Transmission Shaft / Rotary , Big & Small used. | | 48*70*9 |
| YANMER | KLT-750 | 牛腳 | Axle | | 40*65*5 |
| YANMER | KLT-750 | 牛腳 | Axle | | 40*65*14 |
| YANMER | KLT-750 | 牛腳新型 | Axle New Type | | 40*65*9 |
| YANMER | KLT-750 | 耕耘軸大,小,車心 | Transmission Shaft / Rotary , Big & Small used. | AQ2407E | 40*65*11/18 |
| YANMER | KLT-750 | 起動 | Starting | | 30*40*5 |
| YANMER | KLT-750 | 起動 | Starting | | 30*40*7 |
| YANMER | NT65 | 耕耘軸 | Rotary | | 35*55*5 |
| YANMER | NT65 | 耕耘軸大 | Rotary Big | | 35*55*8 |
| YANMER | NT65 | 耕耘軸大 | Rotary Big | | 28*35*22 |
| YANMER | NT65 | 耕耘軸小 | Rotary Small | | 35*55*11 |
| YANMER | NT65 | 耕耘軸小 | Rotary Small | | 25*35*22 |
| YANMER | NT65 | 變速軸 | Speed Changing Shaft | | 12*22*7 |
| YANMER | RR800P | | | | 30*47*8 |
| YANMER | RR800P | | | 24421-204007 | 20*40*7 |
| YANMER | RR800P | ? 驅動軸油壓幫? | Transmission Shaft Hydraulic Pump | 24421-173007 | 17*30*7 |
| YANMER | RR800P | M-主變速,副變速操作 | M- Main Speed Changing, Auxiliary Speed Changing Conductor | 1C6560-17140 | 17*26*6 |
| YANMER | RR800P | 入力軸 | Intake Shaft | 1C6560-13040 | 35*52*8 |
| YANMER | RR800P | 方向盤驅動 | Steering Transmission | 24430-304005 | 30*40*5 |
| YANMER | RR800P | 前傳動軸 | Front Transmission Shaft | 1C6660-22100 | 20*47*10 |
| YANMER | RR800P | 後傳動軸 | Rear Transmission Shaft | 24421-306210 | 30*62*10 |
| YANMER | RR800P | 施肥機驅動軸 | Transmission Shaft | 24421-152507 | 15*25*7 |
| YANMER | RR800P | 施肥機驅動軸 | Transmission Shaft | 24421-122507 | 12*25*7 |
| YANMER | RR800P | 株間變速,出力軸 | Speed Changing, Output Shaft | 24421-173507 | 17*35*7 |
| YANMER | RR800P | 株間變速操作 | Speed Changing Controller | 24421-122207 | 12*22*7 |
| YANMER | RR800P | 旋轉主軸 | Planting Case Rotating Shaft | 1C6560-66130 | 30*42*6.5 |
| YANMER | RR800P | 減行離合軸 | Speed Reducer Clutch Shaft | 1C6054-95130 | 10*20*7 |
| YANMER | RR800P | 橫送?切換 | Horizontal Feeding Shift | 1C6560-63220 | 12*20*5 |
| YANMER | RR800P | 橫送?驅動角牙 | Horizontal Transmission Cross Feed | 24411-223207 | 22*32*7 |
| YANMER | RS27 | 耕耘軸小 | Rotary Small | AQ2890E | 50*80*10 |
| YANMER | RS33 | 耕耘軸大 | Rotary Big | AQ3067E | 55*82*10.5/17 |
| YANMER | RS33 | 耕耘軸小 | Rotary Small | EZ2228A | 62/72*10/13 |
| YANMER | UAR1 | 前輪下面 | Front Wheel Lower | AQ2422E | 40*72*13/16 |
| YANMER | US36 | 後輪 合體 | Rear Wheel | | 75*100*13 |
| YANMER | US40 | 後輪 合體 | Rear Wheel | | 60*75*26 |
| YANMER | US40通用 | 傳動 PTO | Transmission PTO | | 58*80*12 |
| YANMER | US46 | 前輪車軸 | Front Wheel Axle | | 80*105*15 |

WLK Agriculture Machine Used Products.

DATE : 2014/01/03

| BRAND | MODEL | 用處 | APPLICATION | Part No. | Oil Seals Size |
|--------|------------|--------------|----------------------------------|--------------|----------------|
| YANMER | US46加turbo | 前輪站軸上面 | Front Wheel Vertical Shaft Upper | 194171-13870 | 68*90*12 |
| YANMER | US50 | 耕耘軸小 | Rotary Small | | 40*72*15/16 |
| YANMER | US50 | 傳動 PTO | Transmission PTO | AQ2110E | 35*60*12/18 |
| YANMER | USR 1800 | 耕耘軸小 | Rotary Small | 1A1080-48250 | 40*72*15/16 |
| YANMER | USR 2000 | 入力軸 PTO | Intake Shaft PTO | 24421-456209 | 45*62*9 |
| YANMER | USR 2000 | 前輪站軸 | Front Wheel Vertical Shaft | | 50*68*12.5 |
| 力虎 | | | | | 15*30*8 |
| 力虎 | | | | | 32*6 |
| 力虎 | | 1-30 播手防泥 | 1-30 Planting Arm Scraper | 90S08180716 | 8*18*7 |
| 力虎 | | 1-31 播手防泥 | 1-31 Planting Arm Scraper | 90S08180517 | 8*18*5.7 |
| 力虎 | | A-46/A-10 | A-46/A-10 | 90S17350702 | 15*35*7 |
| 力虎 | | B-5 | B-5 | 90S25521208 | 25*52*12 |
| 力虎 | | D-28 | D-28 | 90S15300702 | 15*30*7 |
| 力虎 | | D-8 | D-8 | 90S18350702 | 18*35*7 |
| 力虎 | | H-54 橫直,內鍊三軸 | Planting Arm Cam Shaft | 90S14351459 | 14*35*11/14.5 |
| 力虎 | | H-70 | H-70 | 90S14301313 | 14*30*13 |
| 力虎 | | T-42 | T-42 | 90R06000 | 15*21*3 |
| 力虎 | | T-61 | T-61 | 90U30400600 | 30*40*6 |
| 力虎 | | U-17 | U-17 | 90S30400500 | 30*40*5 |
| 力虎 | | V-15 | V-15 | 90S12180500 | 12*28*5 |
| 力虎 | | W-4 | W-4 | 90U12200500 | 12*20*5 |
| 力虎 | | W-9 | W-9 | 90S12225717 | 12*22*7 |
| 力虎 | | 正農用 | | | 39*46*10 |
| 力虎 | | 蝸桿 | Scroll Rod | | 17*25*4 |
| 力虎 | | 輪軸 | Wheel Shaft | | 20*35*10 |
| 力虎 | MC10 | 輪軸 | Wheel Shaft | 01-01-005 | 20*42*7 |
| 力虎 | MCA1單輪 | 皮帶輪 | Pulley | | 17*35*7 |
| 力虎 | MCA1單輪 | 耕耘軸 | Rotary | 90S25470704 | 25*47*7 |
| 力虎 | MCA1單輪 | 操控 | Control | E123115010 | 主克拉子手柄 |
| 力虎 | MCA1單輪 | 操控 | Control | 1160815002 | 主克拉子鋼索 |
| 力虎 | MCA1單輪 | 操控 | Control | 1160618000 | (頭) |
| 力虎 | MCA1單輪 | 操控 | Control | C381313000 | 加油索 3.6 尺 |
| 力虎 | MCA1單輪 | 操控 | Control | E320256020 | 加油頭(小) |
| 力虎 | MCA1單輪 | 變速齒輪箱 | Speed Changing Gear Case | 90S15350702 | 15*35*7 |
| 力虎 | MCA1單輪 | 變速齒輪箱 | Speed Changing Gear Case | 90S20470702 | 20*47*7 |
| 力虎 | MCA2單輪 | | | | 38*10 |
| 力虎 | MCA2單輪 | | | | 52/60*8.5 |
| 力虎 | MCA2單輪 | 操控 | Control | E123115010 | 主克拉子手柄 |
| 力虎 | MCA2單輪 | 操控 | Control | 1160815002 | 主克拉子鋼索 |
| 力虎 | MCA2單輪 | 操控 | Control | 1160618000 | 主把手上下鋼索組(附彈頭) |
| 力虎 | MCA2單輪 | 操控 | Control | C381313000 | 加油索 3.6尺 |
| 力虎 | MCA2單輪 | 操控 | Control | 01-01-003 | 加油線 Cable 3尺6 |
| 力虎 | MCA2單輪 | 操控 | Control | E320256020 | 加油頭(小) |
| 力虎 | MCA2單輪 | 鏈箱 輪軸 | Chain Case | | 19*38*7 |
| 力虎 | MCA2單輪 | 鏈箱 輪軸 | Chain Case | 20-47-12/14 | 20*47*12/14 |
| 力虎 | MCA2單輪 | 變速齒輪 | Speed Changing Gear | 90S15350702 | 15*35*7 |
| 力虎 | MCA2單輪 | 變速齒輪 | Speed Changing Gear | | 17*40*8 |
| 力虎 | MCA2單輪 | 變速齒輪 | Speed Changing Gear | 90S20470702 | 20*47*7 |

WLK Agriculture Machine Used Products.

DATE : 2014/01/03

| BRAND | MODEL | 用處 | APPLICATION | Part No. | Oil Seals Size |
|-------|---------------|-----------|-----------------------------------|-------------|----------------|
| 力虎 | MCA2單輪 | 變速齒輪, 耕耘軸 | Speed Changing Gear , Rotary | 20-47-12/14 | 20*47*12/14 |
| 力虎 | MCA2單輪 | 變速齒輪, 皮帶輪 | Speed Changing Gear , Pulley | | 17*47*8 |
| 力虎 | MCA4 | 耕耘軸 | Rotary | 01-01-004 | 25*52*10/16 |
| 力虎 | SRV4D雙輪 | 耕刀 | Transmission Shaft | AQ1754E | 30*62*13/15.5 |
| 力虎 | SRV4D雙輪 | 耕耘軸 | Rotary | 90S30621415 | 30*62*8/14.5 |
| 力虎 | SRV4D雙輪 | 輪軸 | Wheel Shaft | AQ2127E | 35*62*13/18 |
| 力虎 | SRV4D雙輪 | 變速齒輪 | Speed Changing Gear | 90S12180500 | 12*18*5 |
| 力虎 | SRV4D雙輪 | 變速齒輪 | Speed Changing Gear | 90S17400802 | 17*40*8 |
| 力虎 | SRV4D雙輪 | 變速齒輪 | Speed Changing Gear | 90S20470702 | 20*47*7 |
| 力虎 | SRV4D雙輪 | 變速齒輪 | Speed Changing Gear | 90S35470702 | 35*47*7 |
| 力虎 | SRV4D雙輪 | 變速齒輪, 輪軸 | Speed Changing Gear , Wheel Shaft | 90S35621914 | 35*62*13/15.5 |
| 力虎 | 力虎履帶車 | 滾輪 | Track Roller | | 25*52*11/18 |
| 大田 | | | | | 20*35*8 |
| 大田 | | | | | 20*35*5.5 |
| 大田 | " | 耕耘軸大 | Rotary Big | | 45*60*30 |
| 大田 | 30 HP | 耕耘軸小 | Rotary Small | | 45*55*27 |
| 大田 | 30 HP三角車心 | 耕耘軸小 | Rotary Small | | 55*70*10 |
| 大田 | 30.50HP TR150 | 耕耘軸大 | Rotary Big | | 60*80*10 |
| 大田 | 50 HP | 耕耘軸小 | Rotary Small | | 70*90*10 |
| 大田 | TF22/TF26 | 耕耘軸大 | Rotary Big | | 35*55*8 |
| 大田 | TF22/TF26 | 耕耘軸大加長型 | Rotary Big Extend Type | | 35*55*8 |
| 大田 | TF22/TF26 | 耕耘軸小 | Rotary Small | | 45*62*9 |
| 大田 | TF22/TF26 | 耕耘軸小(代用) | Rotary Small(Replacement) | | 45*62*9 |
| 大田 | TF22/TF26 | 耕耘軸小2 | Rotary Small2 | | 35*55*8 |
| 大田 | TF22/TF26 | 輪軸 | Wheel Shaft | AQ8305P | 45*70*12/17 |
| 大田 | TF22/TF26 | 輪軸1 | Wheel Shaft 1 | | 45*55*27 |
| 大田 | TF22/TF26 | 輪軸2 | Wheel Shaft 2 | | 55*70*10 |
| 大田 | TR-150,TR-155 | | | | 55*70*10 |
| 大田 | TR-155 | 入力軸PTO | Intake ShaftPTO | | 35*55*8 |
| 大田 | TR-160,TR-165 | | | | 45*55*27 |
| 大田 | TR-165 | 耕耘軸 | Rotary | | 50*65*9 |
| 大田 | TR-185 | 耕耘軸 | Rotary | | 60*80*10 |
| 大田 | TR-185 | 耕耘軸 | Rotary | | 45*60*30 |
| 大田 | TRH181 | | | | 45*70*5 |
| 大田 | TRH191 | 入力軸 | Intake Shaft | | 45*70*12 |
| 大田 | TRH191 | 耕耘軸大 | Rotary Big | | 70*90*10 |
| 大田 | TRH201 | 第二軸)耕耘軸小 | 2nd Shaft Rotary Small | | 55*72*10 |
| 大田 | TRH201 | 第四軸)耕耘軸大 | 4th Shaft Rotary Big | | 60*80*10 |
| 大田 | TRH201 | 第四軸)耕耘軸大 | 4th Shaft Rotary Big | | 45*60*30 |
| 大田百力 | | 72V耕耘軸大 | 72VRotary Big | AQ3241E1 | 60*90*12 |
| 大田百力 | 2.5米 | 耕耘軸大 | Rotary Big | BQ1393Q | 75*105*13 |
| 大象 | | 耕耘軸大 | Rotary Big | | G135 |
| 大橋 | 551/651 | | | 23114-304-0 | 20*38*8 |
| 大橋 | 551/651 | 耕耘軸 | Rotary | 23113-105-0 | 35*55*8 |
| 大橋 | 551/651 | 輪軸 | Wheel Shaft | 23213-107-0 | 40*62*12 |
| 大橋 | AR600/AR700雙輪 | 操作控制系統 | Operation control System | | 主把手上下鋼索組 |
| 大橋 | AR600/AR700雙輪 | 車軸 | Axle | | 35*62*13/19 |

WLK Agriculture Machine Used Products.

DATE : 2014/01/03

| BRAND | MODEL | 用處 | APPLICATION | Part No. | Oil Seals Size |
|-------|---------------|-------------|------------------------------|-----------|----------------|
| 大橋 | AR600/AR700雙輪 | 耕耘軸 | Rotary | | 30*55*8/15 |
| 大橋 | AR600/AR700雙輪 | | | | 主克拉子手柄 |
| 大橋 | AR600/AR700雙輪 | | | | 主克拉子鋼索 |
| 大橋 | AR600/AR700雙輪 | | | | 加油索 |
| 大橋 | AR600/AR700雙輪 | | | | 加油頭 |
| 小牛 | 小牛303 | 輪軸 | Wheel Shaft | | 25*38*8 |
| 小牛 | 小牛無輪碎石機 | 耕耘軸/輪軸 | Rotary / Wheel Shaft | | 25*38*7 |
| 中農 | 14.5HP | 耕耘軸/輪軸 | Rotary / Wheel Shaft | AQ2407E | 40*65*11/18 |
| 佳農 | CN168單輪 | 1-03 操縱部 | 1-03 Control System | 72-001-03 | 加油線 Cable 4尺2 |
| 佳農 | CN168單輪 | 1-04 " | 1-04 " | 72-001-04 | 張力輪手柄組 |
| 佳農 | CN168單輪 | 1-05 " | 1-05 " | 72-001-05 | 張力輪鋼索 |
| 佳農 | CN168單輪 | 2-20 變速齒輪箱 | 2-20 Gear Speed Changing Box | 72-002-20 | 防油華司 |
| 佳農 | CN168單輪 | 2-22 " | 2-22 " | 72-002-22 | P 9 * 2 |
| 佳農 | CN168單輪 | 2-34 " | 2-34 " | 72-002-34 | P 13 * 2 |
| 佳農 | CN168單輪 | 2-40 | 2-40 | 72-002-40 | 17*32*7 |
| 佳農 | CN168單輪 | 2-50 | 2-50 | 72-002-50 | 25*36*5 |
| 佳農 | CN168單輪 | 2-87 " | 2-87 " | 72-002-87 | P 21 * 2 |
| 佳農 | CN168單輪 | 5-15 耕耘部鏈條箱 | 5-15 Chain Case | 72-005-15 | 防油墊片 |
| 佳農 | CN168單輪 | 5-20 代用 | 5-20 Replacement | | 20*47*12/14 |
| 佳農 | CN168單輪 | 6-04 代用 | 6-04 Replacement | | 30*55*8/15 |
| 佳農 | CN168單輪 | 6-04車輪鏈條箱 | 6-04 Chain Case | 72-006-04 | 30*55*10 |
| 春風 | 800/1000型 | 輪軸 | Wheel Shaft | | 35*62*13/15.5 |
| 展農 | | | | | 40*47*4 |
| 展農 | 103單輪 | | | 2-94 | 28*38*5.5 |
| 展農 | 103單輪 | 耕耘軸 輪軸 | Rotary Wheel Shaft | | 25*47*12/14.8 |
| 展農 | 103單輪 | 輪軸 | Wheel Shaft | | 20*47*12/14 |
| 展農 | 103單輪 | 輪軸 | Wheel Shaft | | 25*52*16 |
| 展農 | 103單輪 | 齒輪箱 | Gear Case | 2-40,2-78 | 25*47*8 |
| 展農 | 103單輪 | 操作控制系統 | Operation control System | 1-20 | 張力輪鋼索 |
| 展農 | 103單輪 | | | 1-28 | 主把手上下鋼索組 |
| 展農 | 103單輪 | | | 1-29 | 主把手左右鋼索組 |
| 展農 | 103單輪 加大馬力 | 輪軸 | Wheel Shaft | | 25*52*11/18 |
| 展農 | 206雙輪 | | | | 25*47*7 |
| 展農 | 206雙輪 | | | | 25*52*10 |
| 展農 | 206雙輪 | | | | 25*52*8 |
| 展農 | 206雙輪 | | | 3-51 | 28*38*5.5 |
| 展農 | 206雙輪 | | | 3-26 | 20*42*7 |
| 展農 | 206雙輪 | | | 6-6 | 20*38*8 |
| 展農 | 206雙輪 | 耕耘軸 | Rotary | 6-15 | 25*47*7 |
| 展農 | 206雙輪 | 副馬達機 | Auxiliary Motor | 3-8 | 20*38*7 |
| 展農 | 206雙輪 | 輪軸 | Wheel Shaft | 2-43 | 30*52*8 |
| 展農 | 206雙輪 | 齒輪箱 皮帶輪 | Gear Case Pulley | 2-12 | 28*38*5.5 |
| 展農 | 206雙輪 | 操作控制系統 | Operation control System | 5-22 | 變速鋼索 |
| 展農 | 206雙輪 | | | 5-29,5-30 | 主把手上下(左右)鋼索 |
| 展農 | 206雙輪 | | | 5-35 | 加油索 |
| 展農 | 206雙輪 | | | 5-34 | 加油頭 |
| 展農 | 206雙輪 | | | 5-23 | 張力輪鋼索 |
| 展農 | 206雙輪 | | | 5-32 | 轉向差速鋼索 |
| 展農 | 206雙輪 | | | 5-33 | 轉向控制把手 |
| 展農 | 割樁機 | | | | 30*46*8 |
| 裕農 | YP-650 | 安全開關 支架 | Switch Supporting-Arm | | 15*30*8 |
| 裕農 | YP-650 | 播手曲軸 | Planting Arm Crank Shaft | | 14*30*13 |
| 農州 | 農州 | 皮帶輪軸 | Pulley Shaft | | 20*34*7 |
| 農州 | 農州 | 耕耘軸 | Rotary | | 30*46*7 |

WLK Agriculture Machine Used Products.

DATE : 2014/01/03

| BRAND | MODEL | 用處 | APPLICATION | Part No. | Oil Seals Size |
|-------|-------|----------|------------------------|----------|----------------|
| 農州 | 農州 | 輪軸 | Wheel Shaft | | 25*40*7 |
| 寶島 | | 後輪 | Rear Wheel | | 20*52*8 |
| 寶島 | | 耕耘軸大 | Rotary Big | | 45*70*5 |
| 寶島 | | 耕耘軸大 | Rotary Big | | 45*70*12 |
| 寶島 | | 耕耘軸大(上面) | Rotary Big(Upper) | | 30*55*11 |
| 寶島 | | 耕耘軸小 | Rotary Small | | 35*55*5 |
| 寶島 | | 張力輪 | Tension Pulley | | 20*30*5 |
| 寶島 | | 傳動尺輪箱 | Transmission Gear Case | | 30*50*8 |

HUO SHIN ENTERPRISE CO.,
 NO. 15, ALLEY 221, LANE 23, SEC 2, DIN CHAO RD.,
 LUKANG, CHANGHWA, TAIWAN
WLK Engine Used Oil Seals.

DATE : 2014/01/03

| BRAND | MODEL | 用處 | APPLICATION | Part No. | Oil Seals Size |
|----------|-------------|--------|-------------|-------------|----------------|
| B/S | B/S 3HP(汽油) | | | | 22*32*5 |
| B/S | B/S 9HP(汽油) | | | | 30*43.3*10 |
| B/S | B/S 9HP(汽油) | | | | 33*47.3*10 |
| HONDA | F210 | 曲軸 | Crank Shaft | | 20*40*8 |
| HONDA | G150/200 | | | | 25*41*6 |
| HONDA | G200 | | | | 25*41*6 |
| HONDA | G300 | | | | 25*41*6 |
| HONDA | G300 | | | | 30*46*7 |
| HONDA | G350 | | | | 20*30*8 |
| HONDA | G40/42 | | | | 20*52*8 |
| HONDA | G40/42 | | | | 30*65*10 |
| HONDA | G400 | | | | 30*46*7 |
| HONDA | G65 | | | | 30*75*9 |
| HONDA | G65 | | | | 30*77*9 |
| HONDA | GX120 | 曲軸 | Crank Shaft | | 22*35*6 |
| HONDA | GX120 | 曲軸 | Crank Shaft | | 22*41.25*7 |
| HONDA | GX140 | 曲軸 | Crank Shaft | | 25*41.25*6 |
| HONDA | GX160 | 曲軸 | Crank Shaft | | 25*41*6 |
| HONDA | GX160 | 曲軸 | Crank Shaft | | 25*41.25*6 |
| HONDA | GX240 | 曲軸 | Crank Shaft | | 30*45*8 |
| KAWASAKI | KF34 | | | | 20*35*7 |
| KAWASAKI | KF53 | | | | 22*35*7 |
| KAWASAKI | KF53 | | | | 25*40*7 |
| KAWASAKI | KF64 | | | | 25*35*7 |
| KAWASAKI | KF64 | | | | 30*50*8 |
| KOHLER | K91 | | | | 22*41.3*6 |
| KUBOTA | ER100 | 曲軸 | Crank Shaft | | 54*76*8 |
| KUBOTA | ER100 | 起動 | Starting | | 27*37*7 |
| KUBOTA | ER100 | 起動 | Starting | 09550-27407 | 27*40*7 |
| KUBOTA | ER100 | 起動 | Starting | 14301-62452 | 22*27*12 |
| KUBOTA | ER13HP | 曲軸 | Crank Shaft | | 50*70*10 |
| KUBOTA | ER17 | 曲軸 | Crank Shaft | | 54*76*8 |
| KUBOTA | ER20 HP | | | | 防震螺絲 |
| KUBOTA | ER2000 | 曲軸 | Crank Shaft | | 48*70*12 |
| KUBOTA | ER2000 | 曲軸 | Crank Shaft | | 50*72*12 |
| KUBOTA | ER2200 | 曲軸 | Crank Shaft | | 48*70*12 |
| KUBOTA | ER2200 | 起動 | Starting | 09550-27407 | 27*40*7 |
| KUBOTA | ER2500 | 曲軸 | Crank Shaft | | 48*70*12 |
| KUBOTA | ER50 | 曲軸 | Crank Shaft | 09560-40628 | 40*62*8 |
| KUBOTA | ER50 | 起動 | Starting | 14301-62452 | 22*27*12 |
| KUBOTA | ER600 | 曲軸 | Crank Shaft | | 38*55*8 |
| KUBOTA | ER600 | 起動 | Starting | | 25*35*7 |
| KUBOTA | ER65 | 曲軸 | Crank Shaft | 09560-40628 | 40*62*8 |
| KUBOTA | ER65 | 起動 | Starting | 09550-27407 | 27*40*7 |
| KUBOTA | ER65 | 起動 | Starting | 14301-62052 | 22*27*12 |
| KUBOTA | ER75 | 曲軸 | Crank Shaft | | 50*70*10 |
| KUBOTA | ER-8 | Collar | Collar | 14301-62452 | 22*27*12 |
| KUBOTA | ER80 | 曲軸 | Crank Shaft | | 50*72*9 |
| KUBOTA | ER900 | 曲軸 | Crank Shaft | | 38*55*8 |

WLK Engine Used Oil Seals.

DATE : 2014/01/03

| BRAND | MODEL | 用處 | APPLICATION | Part No. | Oil Seals Size |
|------------|--------------|-----|-------------------|-------------|----------------|
| KUBOTA | ER900 | 起動 | Starting | | 25*35*7 |
| KUBOTA | GA100 | 曲軸 | Crank Shaft | | 40*62*8 |
| KUBOTA | GA120 | 起動 | Starting | 09550-27407 | 27*40*7 |
| KUBOTA | GA80 | 曲軸 | Crank Shaft | | 40*62*8 |
| KUBOTA | KND 70-90 | 起動 | Starting | | 25*37*8 |
| KUBOTA | KND105 | 曲軸 | Crank Shaft | | 38*55*8 |
| KUBOTA | KND105 | 起動 | Starting | | 25*35*7 |
| KUBOTA | KND180 | 曲軸 | Crank Shaft | | 50*72*12 |
| KUBOTA | KND180 | 起動 | Starting | 09550-27407 | 27*40*7 |
| KUBOTA | KND220 | 曲軸 | Crank Shaft | | 50*72*12 |
| KUBOTA | KND220 | 起動 | Starting | 09550-27407 | 27*40*7 |
| KUBOTA | KND3 | 曲軸 | Crank Shaft | | 35*52*9 |
| KUBOTA | KND3-50 | 起動 | Starting | | 22*35*7 |
| KUBOTA | KND40 | 曲軸 | Crank Shaft | | 40*62*12 |
| KUBOTA | KND50 | 起動 | Starting | | 22*35*7 |
| KUBOTA | KND5B | 曲軸 | Crank Shaft | | 40*62*8 |
| KUBOTA | KND5B | 起動 | Starting | | 22*35*7 |
| KUBOTA | KND70 | 曲軸 | Crank Shaft | | 50*70*10 |
| KUBOTA | KND70 | 起動 | Starting | | 25*37*8 |
| KUBOTA | KND70A | 曲軸 | Crank Shaft | | 38*55*8 |
| KUBOTA | KND70A | 起動 | Starting | | 25*35*7 |
| KUBOTA | KND80 | 起動 | Starting | | 25*35*7 |
| KUBOTA | KND90 | 曲軸 | Crank Shaft | | 50*70*10 |
| KUBOTA | KND90 | 起動 | Starting | | 25*37*8 |
| KUBOTA | KNT5B | 曲軸 | Crank Shaft | 09560-40628 | 40*62*8 |
| KUBOTA | KNT70 | 曲軸 | Crank Shaft | | 50*70*10 |
| KUBOTA | KNT70 | 起動 | Starting | | 25*37*8 |
| KUBOTA | PK125 | 曲軸 | Crank Shaft | | 40*55*8 |
| KUBOTA | RK50 = ER600 | 曲軸 | Crank Shaft | | 38*55*8 |
| KUBOTA | RK50 = ER600 | 起動 | Starting | | 25*35*7 |
| mitsubishi | 23 HP | 曲軸 | Crank Shaft | | 48*70*12 |
| mitsubishi | 7 HP 75L | 曲軸 | Crank Shaft | | 42*60*9 |
| mitsubishi | NM110 | 曲軸 | Crank Shaft | | 44*65*6.5/9 |
| mitsubishi | NM110 | 起動 | Starting | | 27*38*6 |
| mitsubishi | NM110 BIG | 曲軸 | Crank Shaft | | 44*65*10 |
| mitsubishi | NM130 | 曲軸 | Crank Shaft | GJ7422P | 48*72*9 |
| mitsubishi | NM130 | 起動 | Starting | | 48*70*12 |
| mitsubishi | NM155 | 曲軸 | Crank Shaft | | 35*48*8 |
| mitsubishi | NM155 | 曲軸 | Crank Shaft | | 52*75*12 |
| mitsubishi | NM155 | 起動 | Starting | | 32*48*8 |
| mitsubishi | NM160 | 曲軸 | Crank Shaft | | 52*75*12 |
| mitsubishi | NM180 | 曲軸 | Crank Shaft | | 52*75*12 |
| mitsubishi | NM180 | 起動 | Starting | | 32*48*8 |
| mitsubishi | NM5.5L | 曲軸 | Crank Shaft | GJ2068E | 35*52*9 |
| mitsubishi | NM5.5L | 曲軸外 | Crank Shaft Outer | | 35*48*8 |
| mitsubishi | NM5.5L | 起動 | Starting | | 27*38*6 |
| mitsubishi | NM55 | 曲軸 | Crank Shaft | | 35*48*8 |
| mitsubishi | NM55 | 曲軸 | Crank Shaft | GJ7536P | 35*52*9 |
| mitsubishi | NM55 | 起動 | Starting | | 27*38*6 |
| mitsubishi | NM65 | | | GJ2361Q | 44*65*6.5/9 |
| mitsubishi | NM65 | 曲軸 | Crank Shaft | | 40*52*8 |
| mitsubishi | NM65 | 曲軸 | Crank Shaft | GJ7536P | 40*55*9 |

WLK Engine Used Oil Seals.

DATE : 2014/01/03

| BRAND | MODEL | 用處 | APPLICATION | Part No. | Oil Seals Size |
|------------|--------------|-----------------|--------------------|------------|------------------|
| mitsubishi | NM65 | 起動 | Starting | | 24*40*8 |
| mitsubishi | NM75 | 曲軸 | Crank Shaft | 42X60X8-TC | 42*60*9 |
| mitsubishi | NM75 | 起動 | Starting | | 27*38*6 |
| mitsubishi | NM85 / M85 | 曲軸 | Crank Shaft | GJ2361Q | 44*65*6.5/9 |
| mitsubishi | NM85 / M85 | 曲軸 | Crank Shaft | | 44*65*10 |
| mitsubishi | NM85 / M85 | 起動 | Starting | | 27*38*6 |
| mitsubishi | NM85/110 | 曲軸 | Crank Shaft | GJ7422P | 44*65*6.5/9 |
| mitsubishi | NM90 | 曲軸 | Crank Shaft | | 44*65*10 |
| mitsubishi | NM90 SMALL | 起動 | Starting | | 27*38*6 |
| mitsubishi | NM90L | 曲軸 | Crank Shaft | GJ7422P | 44*65*6.5/9 |
| mitsubishi | SD10 | | | | 52*75*12 |
| ROBIN | | | | | 20*30*7 |
| ROBIN | EY13 | 曲軸 | Crank Shaft | | 22*35*7 |
| ROBIN | EY13 | 曲軸 | Crank Shaft | | 22*41.25*7 |
| ROBIN | EY14 | 曲軸 | Crank Shaft | | 20*30*7 |
| ROBIN | EY14 | 曲軸 | Crank Shaft | | 22*41.25*7 |
| ROBIN | EY15 | 曲軸,BIG | Crank Shaft ,BIG | | 25*41.25*7 |
| ROBIN | EY15 | 曲軸,SMALL | Crank Shaft ,SMALL | | 25*38*7 |
| ROBIN | EY18 | 曲軸 | Crank Shaft | | 25*38*7 |
| ROBIN | EY18 | 曲軸 | Crank Shaft | | 25*41.25*7 |
| ROBIN | EY20 | 曲軸 | Crank Shaft | | 25*38*7 |
| ROBIN | EY20 | 曲軸 | Crank Shaft | | 25*41.25*7 |
| ROBIN | EY25 | 曲軸 | Crank Shaft | | 31*42*8 |
| ROBIN | EY25 | 曲軸 | Crank Shaft | | 30*45*8 |
| STIHL | | | | | 18*30*7 |
| STIHL | | | | | 12*32*7 |
| YAMAHA | MT110/ET1500 | 曲軸 | Crank Shaft | | 25*41.25*7 |
| YANMER | | Valve Stem Seal | Valve Stem Seal | | 14*19/22*19.7/23 |
| YANMER | | 曲軸 | Crank Shaft | | 35*47*5 |
| YANMER | | 曲軸 | Crank Shaft | | 38*55*10.5 |
| YANMER | | 曲軸 | Crank Shaft | | 55*72*12 |
| YANMER | | 起動 | Starting | | 28*40*5 |
| YANMER | 12 HP | 曲軸 | Crank Shaft | | 65*88*12 |
| YANMER | 16 HP | 曲軸 | Crank Shaft | | 58*90*11 |
| YANMER | 24 HP | 曲軸 | Crank Shaft | | 60*90*11 |
| YANMER | 33 HP | 曲軸 | Crank Shaft | | 70*90*12 |
| YANMER | F10 | 曲軸 | Crank Shaft | | 58*80*12 |
| YANMER | F10 | 曲軸 | Crank Shaft | | 58*80*13 |
| YANMER | F10 | 起動 | Starting | | 26*40*5 |
| YANMER | F12 | 曲軸 | Crank Shaft | | 75*105*15 |
| YANMER | F4 | 曲軸 | Crank Shaft | | 45*57*5/7.5 |
| YANMER | F4 | 起動 | Starting | | 20*35*4.5 |
| YANMER | F5 | 曲軸 | Crank Shaft | | 48*66*13 |
| YANMER | F5 | 起動 | Starting | | 20*35*4.5 |
| YANMER | F6 | 曲軸 | Crank Shaft | | 52*75*13 |
| YANMER | F6 | 起動 | Starting | | 26*40*5 |
| YANMER | F7 | 曲軸 | Crank Shaft | | 58*80*13 |
| YANMER | F7/F8/F9 | 曲軸 | Crank Shaft | | 58*80*12 |
| YANMER | F7/F8/F9 | 曲軸 | Crank Shaft | | 57*80*13 |
| YANMER | F7/F8/F9 | 曲軸 | Crank Shaft | | 56*80*13 |
| YANMER | F8 | 曲軸 | Crank Shaft | | 58*80*13 |
| YANMER | N15Y | | | | 68*90*13 |

WLK Engine Used Oil Seals.

DATE : 2014/01/03

| BRAND | MODEL | 用處 | APPLICATION | Part No. | Oil Seals Size |
|--------|--------------|---------------|-----------------------|--------------|----------------|
| YANMER | N22Y | | | | 70*90*12 |
| YANMER | N22Y | CRANKSHAFT | CRANKSHAFT | | 88*115*13 |
| YANMER | NT110 | 曲軸 | Crank Shaft | | 68*90*12 |
| YANMER | NT65 | 曲軸 | Crank Shaft | GJ7422P | 45*57*5/7.5 |
| YANMER | NT65 | 起動 | Starting | | 20*35*4.5 |
| YANMER | NT70 | 曲軸 | Crank Shaft | | 48*66*13 |
| YANMER | NT70 | 起動 | Starting | | 20*35*4.5 |
| YANMER | NT75 | 曲軸 | Crank Shaft | | 52*75*13 |
| YANMER | NT75 | 起動 | Starting | | 26*35*5 |
| YANMER | NT85 | 曲軸 | Crank Shaft | | 58*80*13 |
| YANMER | NT85 | 起動 | Starting | | 26*40*5 |
| YANMER | NT95 | 曲軸 | Crank Shaft | | 58*80*13 |
| YANMER | NT95 | 起動 | Starting | | 26*40*5 |
| YANMER | TF160 | 曲軸合銅 | Crank Shaft | | 58*72*9 |
| YANMER | TF160 | 起動 | Starting | | 25*35*5 |
| YANMER | TS105 | 曲軸合銅 | Crank Shaft | | 52*70*9 |
| YANMER | TS105 | 起動 | Starting | | 25*35*5 |
| YANMER | TS105C | 曲軸珠 | Crank Shaft (Bearing) | | 50*68*9 |
| YANMER | TS105C | 起動 | Starting | | 25*35*5 |
| YANMER | TS105M | | | 103338-02220 | 52*70*9 |
| YANMER | TS130 | 曲軸合銅 | Crank Shaft | | 56*70*9 |
| YANMER | TS130 | 起動 | Starting | | 28*45*6 |
| YANMER | TS130C | 曲軸珠 | Crank Shaft (Bearing) | | 55*72*9 |
| YANMER | TS130C | 起動 | Starting | | 28*45*6 |
| YANMER | TS155 | 曲軸合銅 | Crank Shaft | | 58*75*9 |
| YANMER | TS155 | 起動 | Starting | | 32*45*6 |
| YANMER | TS155C | 曲軸珠 | Crank Shaft (Bearing) | | 58*75*9 |
| YANMER | TS155C | 起動 | Starting | | 32*45*6 |
| YANMER | TS180 | 曲軸合銅 | Crank Shaft | | 58*72*9 |
| YANMER | TS180 | 起動 | Starting | | 26*40*6 |
| YANMER | TS180C | 曲軸珠 | Crank Shaft (Bearing) | | 58*75*9 |
| YANMER | TS180C | 起動 | Starting | | 26*40*6 |
| YANMER | TS190 | 曲軸合銅 | Crank Shaft | | 58*75*9 |
| YANMER | TS190C | 曲軸合銅 | Crank Shaft | | 58*75*9 |
| YANMER | TS200 | 曲軸 | Crank Shaft | | 50*72*12 |
| YANMER | TS220 | 曲軸珠 | Crank Shaft (Bearing) | | 70*92*12 |
| YANMER | TS220 | 起動 | Starting | | 32*45*5 |
| YANMER | TS230 | 曲軸合銅 | Crank Shaft | | 62*80*9 |
| YANMER | TS230 | 起動 | Starting | | 32*45*6 |
| YANMER | TS230C | 曲軸 | Crank Shaft | | 62*80*9 |
| YANMER | TS50 | CRANK SHAFT | Crank Shaft | 104100-02220 | 42*58*8 |
| YANMER | TS50 | 起動(STARTING) | Starting | 104200-76500 | 25*35*5 |
| YANMER | TS50C | 起動 | Starting | | 25*35*5 |
| YANMER | TS50C 有培林 | 曲軸珠 | Crank Shaft (Bearing) | 40X62X8-TC | 40*62*8 |
| YANMER | TS60 | 曲軸合銅(BUSH) | Crank Shaft | 104200-02220 | 44*60*9 |
| YANMER | TS60 | 起動(STARTING) | Starting | 104200-76500 | 25*35*5 |
| YANMER | TS60 ~ TS180 | 油杯仔用 | Oil Cup Used | | P 33 * 2 |
| YANMER | TS60 ~ TS180 | 油杯仔用 | Oil Cup Used | | P 45 * 2 |
| YANMER | TS60C | 曲軸珠 曲軸(RACER) | Crank Shaft (Bearing) | | |
| YANMER | TS60C | 曲軸珠 曲軸(RACER) | Crank Shaft | 104200-02220 | 45*62*9 |
| YANMER | TS60C | 起動(STARTING) | Starting | 104200-76500 | 25*35*5 |
| YANMER | TS70 | 曲軸合銅 | Crank Shaft | 103288-02220 | 50*68*9 |

WLK Engine Used Oil Seals.

DATE : 2014/01/03

| BRAND | MODEL | 用處 | APPLICATION | Part No. | Oil Seals Size |
|--------|--------------|---------------|--------------------------------------|--------------|-----------------|
| YANMER | TS70 | 起動 起動 | Starting | | 25*35*5 |
| YANMER | TS70C | 曲軸珠 曲軸 | Crank Shaft (Bearing) Crank Shaft | | 50*68*9 |
| YANMER | TS70C | 起動 起動 | Starting | | 25*35*5 |
| YANMER | TS80 | 曲軸合銅 | Crank Shaft | | 50*68*9 |
| YANMER | TS80 | 起動 起動 | Starting | | 25*35*5 |
| YANMER | TS80C | 曲軸珠 曲軸 | Crank Shaft (Bearing) Crank Shaft | | 50*68*9 |
| YANMER | TS80C | 起動 起動 | Starting | | 25*35*5 |
| YANMER | TS80M | | | 103288-02220 | 50*68*9 |
| | 1SM | | | AQ8270P | 60*80/90*11 |
| | 2S | THRUST SHAFT | THRUST SHAFT | | 50*72*12 |
| | 2S | 曲軸 | Crank Shaft | AC8176P | 55*78*12 |
| | 2T/3T | C.W. PUPM | C.W. PUPM | | 35*47*5 |
| | 2T/3T | Cam Shaft | Cam Shaft | | 38*55/63.5*10.5 |
| | 2T/3T | R. GEAR SHAFT | R. GEAR SHAFT | | 58*90*11 |
| | 2T/3T | THRUST SHAFT | THRUST SHAFT | | 60*90*11 |
| | 2T/3T | 曲軸 | Crank Shaft | | 65*88*12 |
| | 3/4 AHU | THRUST SHAFT | THRUST SHAFT | | 75*100*13 |
| | 3ES | C.W. PUPM | C.W. PUPM | | 45*60*6 |
| | 3ES (105-31) | | | | 55*78*12 |
| | 3ES (108-24) | | | | 80*105*13 |
| | 3ES (7-15) | | | | 38*50*8 |
| | 3ES (8-43) | | | | 70*95*13 |
| | 45 AHU | | | | 14*24*7 |
| | 45 AHU | | | | 12*25*7 |
| | 5/6 AHU | THRUST SHAFT | THRUST SHAFT | | 90*115*13 |
| | 5/6 AHU | THRUST SHAFT | THRUST SHAFT | | 100*125*13 |
| | 5/6 AHU | THRUST SHAFT | THRUST SHAFT | | 115*145*14 |
| | 6LDF | | | | 100*125*13 |
| | AEL | 曲軸 | Crank Shaft | | 45*70*12 |
| | AL2 | 曲軸 | Crank Shaft | | 45*68*12 |
| | D850 | Crank Shaft | Crank Shaft | | 63*80*9 |
| | D950 | Crank Shaft | Crank Shaft | | 30*44*5 |
| | DF195 | 曲軸 | Crank Shaft | | 50*80*12 |
| | DF195 | 起動 | Starting | | 35*58*12 |
| | E300 | | | | 15*24*5 |
| | EM500 | | | | 15*24*5 |
| | EM500 | | | | 17*30*6 |
| | EMG | | | | 52*72/82*11 |
| | EP500 | | | | 6*12*4 |
| | EP500 | | | | 20*30*7 |
| | ES | THRUST SHAFT | THRUST SHAFT | | 45*60*6 |
| | ES | THRUST SHAFT | THRUST SHAFT | | 55*78*12 |
| | ES | 曲軸 | Crank Shaft | | 70*95*13 |
| | GA70 | OIL INDICATOR | OIL INDICATOR | 14431-3330-1 | 5*12*3.5 |
| | IDVA(船用) | | | | 35*46*7 |
| | IDVA(船用) | | | | 28*48*11 |
| | IDVA(船用) | | | | 48*70/94*12.5 |
| | K4 | | | | 22*41.3*6 |
| | K7 | | | | 28*38*7 |
| | K7 | | | | 28*41*6 |
| | K7 | AXLE SEALS | AXLE SEALS | | 50*66/75*9.3/14 |
| | K91 | | | | 22*41.3*6 |
| | KD | THRUST SHAFT | THRUST SHAFT | | 58*80*12 |
| | L40 | | | | 25*41.3*8 |

WLK Engine Used Oil Seals.

DATE : 2014/01/03

| BRAND | MODEL | 用處 | APPLICATION | Part No. | Oil Seals Size |
|-------|-------------------|--------------|--------------|--------------|--------------------|
| | LDF | | | | 80*105*13 |
| | LDF | | | | 90*115*13 |
| | LDF | | | | 80*125*13 |
| | LDF | | | | 100*125*13 |
| | LDF | BILGE PUPM | BILGE PUPM | | 28*40*6 |
| | M11 | 曲軸 | Crank Shaft | | 48*70*12 |
| | M11 | 起動 | Starting | | 32*45*8 |
| | M130 | 曲軸 | Crank Shaft | | 48*70*12 |
| | MF150 | | | | 25*35*7 |
| | MF150 | | | | 25*40*5 |
| | MF180 | | | | 25*35*7 |
| | MF180 | | | | 25*40*5 |
| | N12 | 曲軸 | Crank Shaft | | 30*50*10 |
| | N12 | 曲軸 | Crank Shaft | | 30*55*10 |
| | NN2 | 曲軸 | Crank Shaft | | 30*45*8 |
| | PF195 | | | | 50*80*13 |
| | PMY4 | 曲軸 | Crank Shaft | | 48*66*13 |
| | PMY5 | | | | 50*65/75*9/5 |
| | PMY5 | 曲軸 | Crank Shaft | | 58*80*13 |
| | RK50 | | | | 38*55*8 |
| | SM | Cam Shaft | Cam Shaft | | 60*80*12 |
| | SM | THRUST SHAFT | THRUST SHAFT | | 60*78*9 |
| | SM | 曲軸 | Crank Shaft | | 55*72*12 |
| | SM1586 | Cam Shaft | Cam Shaft | | 65*90*13 |
| | SS4 | 曲軸 | Crank Shaft | | 58*80*12 |
| | ST95 | THRUST SHAFT | THRUST SHAFT | | 45*61*9 |
| | ST95 | 曲軸 | Crank Shaft | | 58*80*12 |
| | SUZUE | ROTARY | ROTARY | | 30*50*15 |
| | YZC | | | 1A1280-48820 | 30*45*8 |
| | YZC | COVER | COVER | AQ8176P | 31*65/80*15 |
| | YZC | HOLDER | HOLDER | 1A1030-23680 | 30*40*17/24.5 |
| | YZC | ROTARY | ROTARY | 1A1280-48450 | 30*55*11.5/19 |
| | YZC(YC60) , 03-41 | 輪軸心國 | Wheel Shaft | 1A1030-28680 | 45*64/73*14.5 |
| | ZB600 | | | | 65*80*9 |
| | | | | AZ8137P | 40*78/84.5*13.5/18 |
| | | | | 90S12180500 | 12*18*5 |
| | | | | | 60.33*85.73*22.23 |
| | | | | | 38.1*50.8*6.3 |
| | | | | | 75*100*10 |
| | | | | | 44.45*68.26*16.5 |
| | | | | | 45*80/91.5*10/18 |

APLICACIONES DEL HOGAR

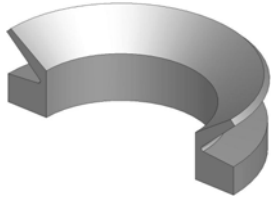
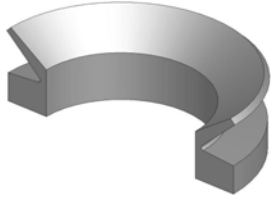
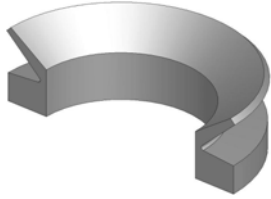
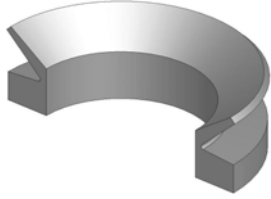
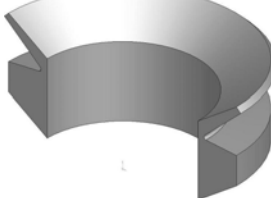
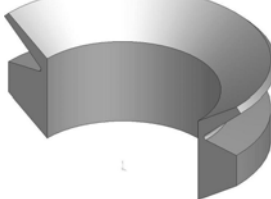
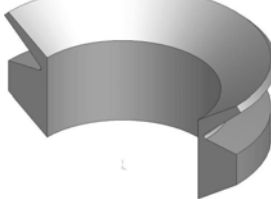

| SIZE | Application Reference | 3D Drawing |
|--------------------------------|--|---|
| H-12DAP CERAMIC / CARBON / NBR | Coat seal bearing and mirror bakelite set General Screw Candy, Whirlpool , Philips, Ignis UNIVERSALE |  |
| VA020 | |  |
| VA022 | INDESIT |  |
| VA025 | INDESIT |  |
| VA028 | |  |
| VA030 | |  |

| SIZE | Application Reference | 3D Drawing |
|-------|---|---|
| VA035 | |  |
| VA038 | |  |
| VA040 | Bauknecht, Whirlpool washing machine V ring |  |
| VA050 | INDESIT |  |
| VS020 | |  |
| VS025 | |  |
| VS035 | |  |

| SIZE | Application Reference | 3D Drawing |
|-----------------|-----------------------------------|---|
| VS080 | |  |
| 4.5*16*7 | Zanussi, Varie Marche, Electrolux |  |
| 4.5*16*7 | Zanussi, Varie Marche, Electrolux |  |
| 4.5*16/57*7 | Sole, GORENJE |  |
| 4.5*16/57*7/8.5 | Sole, Zanussi, Ariston, Gorenje |  |
| 5*18*7 | |  |
| 5*18*7 | |  |
| 6*19*7 | Hoover |  |

| SIZE | Application Reference | 3D Drawing |
|------------------|--|---|
| 6*20*6 | |  |
| 10*20*7 | |  |
| 12*20*7 | |  |
| 12*21*7 | |  |
| 5*21/54.5*9 | Selni |  |
| 6*21/53*8 | Copreci |  |
| 6*21.5/55*12 | Plaset |  |
| 15.88*21.63*8.74 | LMB-000/721-0362 MABE Inferior Medium |  |

| SIZE | Application Reference | 3D Drawing |
|------------------|--|---|
| 15.47*21.82*5.16 | |  |
| 5*22/53*11 | Plaset |  |
| 6*22*7 | Universale Elettropompa Doppio |  |
| 6*22*7 | Universal |  |
| 6*22/59*8/11.5 | Plaset, Philips Bauknecht |  |
| 6*22/67*8/10 | Plaset, San Giorgio, Ariston, Varie |  |
| 8*22*7 | C.G.E. |  |

| SIZE | Application Reference | 3D Drawing |
|---------|--------------------------------|---|
| 9*22*7 | |  |
| 10*22*7 | Universale |  |
| 11*22*7 | Ariston, Indesit |  |
| 12*22*7 | Ariston, Indesit, Światowid |  |
| 12*23*9 | |  |
| 10*24*7 | Deawoo |  |
| 12*24*7 | Castor |  |
| 15*24*7 | Varie Marche, Universale |  |

| SIZE | Application Reference | 3D Drawing |
|----------------------|--------------------------------------|---|
| 11*25*7 | |  |
| 12*25*7 | Romo |  |
| 13*25*12.7 | |  |
| 14*25*7 | |  |
| 15.88*25.4*7.95/9.53 | LMB-002/721-0355 MABE Upper Large |  |
| 10*26*7 | Universal |  |
| 5*26.5/31.5*8 | Hanning Universale |  |

| SIZE | Application Reference | 3D Drawing |
|----------------|-------------------------------|---|
| 6*28/54.5*10.2 | Siemens, Bosch, Constructa |  |
| 12*28*7 | |  |
| 17*28*7 | Varie Marche, Universale |  |
| 14*30*7 | San Giorgio |  |
| 15*30*7 | Universale |  |
| 17*30*7 | Universal |  |
| 18*30*8 | |  |
| 20*30*7 | |  |

| SIZE | Application Reference | 3D Drawing |
|----------|--|---|
| 15*35*7 | |  |
| 25*35*7 | Varie Marche, Universale |  |
| 20*40*7 | San Giorgio, Ariston, ARDO |  |
| 20*40*10 | San Giorgio, Ariston |  |
| 20*40*10 | WHIRLPOOL |  |
| 21*40*7 | Ardo Merloni, Blomberg, Bendix, Servis |  |
| 22*40*8 | INDESIT |  |

| SIZE | Application Reference | 3D Drawing |
|-----------------|---|---|
| 22*40*8.5 | Ariston, Merloni, INDESIT, ZANUSSI |  |
| 22*40*8/11.5 | Zanussi, Castor, ELECTROLUX, UNIVERSALE |  |
| 22*40*8/11.5 | Zanussi, Castor, ELECTROLUX, UNIVERSALE |  |
| 22*40*10 | Fagor, CANDY |  |
| 22*40*10/11.5 | Balay, WHIRLPOOL, FAGOR |  |
| 22*40/51*8/12 | Zanussi Rex, ELECTROLUX |  |
| 22*40/66*9/14.5 | Zanussi Rex, ELECTROLUX, Quelle, Zanker |  |

| SIZE | Application Reference | 3D Drawing |
|-------------|------------------------------|---|
| 30*40*7 | Universale |  |
| 22*42*11/12 | BALAY, BOSCH, SIEMENS |  |
| 25*42*7 | Ignis, Philips |  |
| 25*42*7 | Ignis, Philips |  |
| 22*45*9 | Whirlpool, Philips, Ignis |  |
| 25*46*7 | Ariston, Universal |  |
| 25*46*7 | INDESIT |  |

| SIZE | Application Reference | 3D Drawing |
|-------------|--|---|
| 23*47*10 | Candy, Zerowatt |  |
| 25*47*7 | Candy, Ariston, Riber, Universal |  |
| 25*47*8 | Indesit Crociera, CANDY |  |
| 25*47*8.7 | Candy, Zerowatt |  |
| 25*47*10 | Merloni, Ariston, Candy |  |
| 25*47*10 | Indesit, Ariston, Merloni, Universal, Doppia Molla |  |
| 25*47*10/12 | Candy, Zerowatt |  |

| SIZE | Application Reference | 3D Drawing |
|-----------------|-------------------------|---|
| 25*47/54*12.5 | Gorenje |  |
| 25*47/64*7/10.5 | Ariston Merloni Indesit |  |
| 26*47*10 | Universale, Wiatka |  |
| 27*47*7 | Elinda |  |
| 27*47*10 | |  |
| 30*47*6 | Candy, Zerowatt |  |
| 30*47*7 | Zerowatt |  |

| SIZE | Application Reference | 3D Drawing |
|-------------|---|---|
| 30*47*7 | Zerowatt |  |
| 30*47*10 | Zerowatt |  |
| 25*49*10/15 | Philco, Ariston Merloni, Philco Smeg |  |
| 24.5*50*9 | Whirlpool, Philips, Ignis |  |
| 25*50*10 | Ariston, INDESIT, Beko, Whirlpool |  |
| 25*50.55*10 | |  |
| 25*52*7 | Varie Marche, Ardo |  |

| SIZE | Application Reference | 3D Drawing |
|----------------|---------------------------------------|---|
| 25*52*8/11.5 | Tricity Bendix, Zanussi, Universal |  |
| 25*52/103*8/24 | ELECTROLUX 1247806001, Zanussi |  |
| 28*52*6 | Zerowatt, Candy |  |
| 28*52*7 | Candy |  |
| 28*52*10 | Bosch, Siemens, Zerowatt |  |
| 28*52*9/11.5 | BOSCH, 00124097, Siemens |  |
| 30*52*7 | Universale |  |

| SIZE | Application Reference | 3D Drawing |
|------------------|---|---|
| 30*52*7 | EXPORT ENGLAND |  |
| 30*52*10 | Zanussi Castor Riber Smeg, Creda 17000 Series, Hotpoint 18, 95, 97, 99, WD, WM Series , ELECTROLUX, INDESIT |  |
| 30*52*10/12 | Electrolux, Tricity Bendix, Zanussi Castor |  |
| 30*52/60*11/15 | Candy 2W |  |
| 30*52/62*8/12 | Electrolux, Zanker, Zanussi |  |
| 30*52/65*7/10 | INDESIT, Ariston A1124UK/1134UK |  |
| 30*52/66*12/16.5 | Bosch, Electrolux, Siemens, Zanussi Rex |  |

| SIZE | Application Reference | 3D Drawing |
|-----------------|---|---|
| 31*52*7 | Bauknecht, Ignis, Philips, Whirlpool, Zanussi, CASTOR |  |
| 32*52*7 | Zoppas, Candy, Siltal, Triplex, UNIVERSALE |  |
| 32*52*10 | Bosch, Mastercook, Siemens |  |
| 32*52/78*8/14.8 | Bosch, Siemens, Universal, BALAY |  |
| 35*52*7 | Varie Marche, Universale |  |
| 35*52*11.8 | Indesit(Doppio Labbro) |  |
| 35*52*12 NBR 85 | Universal, INDESIT, ARISTON |  |

| SIZE | Application Reference | 3D Drawing |
|------------------|--|---|
| 35*52/65*8/10 | Ariston, Merloni, Indesit, Scholtes, Universal |  |
| 36*52*11 | |  |
| 38*52*7 | Indesit, Ariston Merloni |  |
| 40*52*7 | Ariston, Indesit, Emerald, Magnadine |  |
| 30*53/60*10/13 | Candy 2W, Zerowatt, Candy Charm, Miele |  |
| 30*53/63*10.5/15 | AEG, Electrolux |  |
| 30*53.5*9/14 | Gorenje |  |

| SIZE | Application Reference | 3D Drawing |
|---------------|---|---|
| 30*53.5*10/14 | Zanussi DL, Bendix, Crosslee, Indesit, Philco, ELECTROLUX |  |
| 24*55*10/12 | Candy, S Georgia |  |
| 24*55*10/12 | San Giorgio 95 Ocean |  |
| 25*55/68*8/11 | Polar SL, Sital, Eskimo, UNIVERSALE |  |
| 30*55*7 | Bauknecht, Fagor, S Georgia, Ocean |  |
| 30*55*9 | Whirlpool |  |
| 30*55*10 | Amica, Bauknecht, Candy, Whirlpool, Zerowatt |  |

| SIZE | Application Reference | 3D Drawing |
|---------------|---|---|
| 30*55*10/12 | Ocean, S Georgia |  |
| 30*55/68*8/11 | Polar SL346, Siltal, Whirlpool |  |
| 35*55*9 | |  |
| 35*55*10 | San Giorgio, CANDY |  |
| 38*55*7 | Ariston, Indesit |  |
| 38*55*8 | Indesit |  |
| 32*56*10 | AEG, Ardo, Polar Diana, Merloni, Polar P565 |  |

| SIZE | Application Reference | 3D Drawing |
|--------------------|--|---|
| 40*56*8 | Phillips, Ignis, Whirlpoo |  |
| 39*57/63*16 | Hoover 1100rpm models, Servic Quartz Series Washing Machine Carbon faced bearings oil seal |  |
| 30*60*10 | ARDO, Zerowatt |  |
| 40*60*10 | Siemens, Bosch, Zanussi |  |
| 40.2*60*8/10.5 | Electrolux, Tricity Bendix, Zanussi, Universal |  |
| 40.2*60/86*10.5/16 | Zanussi Rex, Electrolux, Tricity Bendix, Universal |  |
| 40.2*60/105*8/15.5 | ELECTROLUX 1247807009 |  |

| SIZE | Application Reference | 3D Drawing |
|---------------------|---|---|
| 45*60*7 | Sital, Siemens, Ignis Philips |  |
| 28*62*10/12 | BOSCH |  |
| 30*62/69*9.5/16 | |  |
| 35*62*10 | San Giorgio, Ardo, Merloni, Bendix, Electra, Servis, Philips Whirlpool |  |
| 35*62*10/12.5 | Aeg, Electrolux, Tricity Bendix, Zanussi |  |
| 35*62/75*7/10 | Ariston A1100UK/1124UK, Indesit, Merloni |  |
| 35*62/78.5*7.5/10.5 | Ariston, Creda, Indesit, New World |  |

| SIZE | Application Reference | 3D Drawing |
|---------------------|--|---|
| 37.4*62*10/12 TG69Y | Siemens |  |
| 40*62*10 | Beko, Bosch, Zanussi, Stice, Atlas Electrolux |  |
| 40*62/78*8/14.8 | BOSCH, SIEMENS |  |
| 40*62/78*10.2/15.5 | Arcelic Beco Bosch Siemens Constructa, Universal |  |
| 42*62*10 | Sital, Philco |  |
| 45*62*7 | Philco, Universale |  |
| 30*62.4*11/17.5 | 81019 |  |

| SIZE | Application Reference | 3D Drawing |
|------------------|---|---|
| 30*63*15/17 | LG |  |
| 30*63.3/57*18/28 | 228C2451P001/228C 2113P001 Mabe Tank Amazonas |  |
| 35*63.3*9/12.5 | INDESIT, ARISTON |  |
| 32*63.5*8.5/17.5 | WH02X10032 MABE Tank Olimpia 3 Lips |  |
| 30*64*15/23 | |  |
| 35*65*10 | Varie, Universale, ARDO |  |
| 35*65*10 | WHIRLPOOL |  |

| SIZE | Application Reference | 3D Drawing |
|-------------------|------------------------|---|
| 35*65*11/15 | Gorenje, Polar PDG |  |
| 35*65/73.5*7.5/13 | Gorenje |  |
| 35*65/74*10/14.5 | Gorenje |  |
| 40*65*10 | Ariston, Philco, Pitos |  |
| 45*65*8 | Philco |  |
| 45*65*10 | Siltal, Siemens |  |
| 45*65*10 | Siltal, Siemens |  |

| SIZE | Application Reference | 3D Drawing |
|-------------------|---|---|
| 37*66*9.5 | |  |
| 37*66*9.5/12 | LG 4036ER2003A |  |
| 37*66*9.5/14 | LG |  |
| 40*66*10/11.5 | HAIER 0020300440 |  |
| 48*68/110*6/13 | ELECTROLUX 1240296002, Zanussi, Rex, Zoppas |  |
| 27*70*9/19 | ELECTROLUX |  |
| 27*55.5/70*9/18.5 | ELECTROLUX |  |

| SIZE | Application Reference | 3D Drawing |
|----------------------|--|---|
| 40*70/80*12/14 | AEG, Bosch, Constructa, Siemens |  |
| 35*72*10/12 | BOSCH #171291, Siemens |  |
| 35*72*12.5/16.5 TC9Y | Polar PDN885 |  |
| 35*72/79*11/16 | |  |
| 35*72/88*11/18 | |  |
| 39.5*72/78*11/14.5 | GORENJE 587423 |  |
| 40.2*72*10/13.5 | Zanussi Rex, Electrolux, Tricity Bendix, Universal |  |

| SIZE | Application Reference | 3D Drawing |
|------------------------------|---|---|
| 40.2*72/80*8/13 | Zanussi Rex, ELECTROLUX |  |
| 35*72.5/75*12.5/15.75/36 | Hotpoint SCR, WF, WMA, WMM, WMS, WMT washing machine carbon faced bearing oil seal for machines manufactured |  |
| 35*72.5/76*12.5/19 | Ariston A, AMXXF, AXXFL, AVXXF, AVXXL Series: Creda W, WMA Series: Hotpoint FEW, SCR, WD, WF, WMA WMM, WMS, WMT, WT: Indesit AVXXL |  |
| 36.91*72.62/88.49*9.12/15.47 | LG |  |
| 35*74/81*11/15 | Ignis, Philips, Bauknecht, UNIVERSALE, WHIRLPOOL |  |
| 40*74/80*14.5 | Philips, Bauknecht, WHIRLPOOL. ELECTROLUX |  |

| SIZE | Application Reference | 3D Drawing |
|------------------|---|---|
| 34.5*75/76*11/12 | Whirlpool, Philips, Ignis |  |
| 45*75*10 | Aeg, Electrolux |  |
| 35*76*10/14 | Miele, Universal |  |
| 37*76*9.5/12 | FOR WASHING MACHINE WITH DIRECT DRIVE FOR TUB BEARINGS 6305 AND 6306 - LG |  |
| 45*78/88*12/15 | Bosch, AEG |  |
| 40.2*80/88*8/15 | |  |

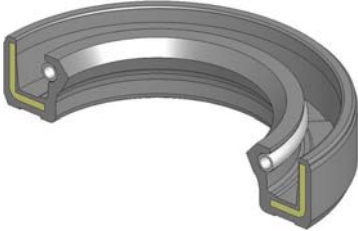
| SIZE | Application Reference | 3D Drawing |
|------------------|---------------------------|---|
| 40.2*80/95*10/15 | ELECTROLUX 1242197000 |  |
| 47*80*10/12 | BOSCH 613084 or 416363 |  |
| 58*80*10 | Universale |  |
| 60*85*10 | Universale |  |
| 16*96*30 Y | |  |
| 14*96*30 Y | |  |

3D Drawing is only for image, not for scale



France Field, Zona Libre de Colón • Apdo. 0816-01993 Panamá, Rep. de Panamá
Tel.: (507) 261-5215 - Fax: (507) 261-5209
ventas@sylinternationalcorp.com

www.sylpanama.com